

YASKAWA AC Drive-A1000

High Performance Vector Control Drive

Technical Manual

Type: CIMR-AU□A□□

Models: 200 V Class: 0.4 to 110 kW (3/4 to 175 HP ND)
400 V Class: 0.4 to 630 kW (3/4 to 1000 HP ND)
600 V Class: 0.75 to 185 kW (1 to 250 HP ND)

To properly use the product, read this manual thoroughly and retain for easy reference, inspection, and maintenance. Ensure the end user receives this manual.

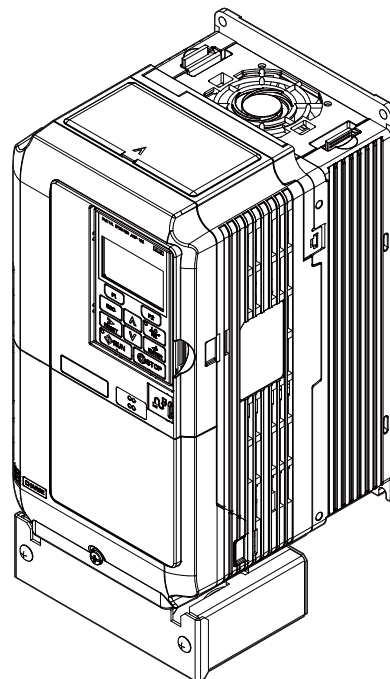

Receiving **1**

Mechanical Installation **2**

Electrical Installation **3**

Start-Up Programming & Operation **4**

Parameter Details **5**

Troubleshooting **6**

Periodic Inspection & Maintenance **7**

Peripheral Devices & Options **8**

Specifications **A**

Parameter List **B**

MEMOBUS/Modbus Communications **C**



Standards Compliance **D**

Quick Reference Sheet **E**

Copyright © 2010 YASKAWA ELECTRIC CORPORATION. All rights reserved.

No part of this publication may be reproduced, stored in a retrieval system, or transmitted, in any form or by any means, mechanical, electronic, photocopying, recording, or otherwise, without the prior written permission of Yaskawa. No patent liability is assumed with respect to the use of the information contained herein. Moreover, because Yaskawa is constantly striving to improve its high-quality products, the information contained in this manual is subject to change without notice. Every precaution has been taken in the preparation of this manual. Yaskawa assumes no responsibility for errors or omissions. Neither is any liability assumed for damages resulting from the use of the information contained in this publication.

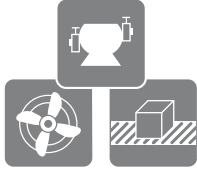
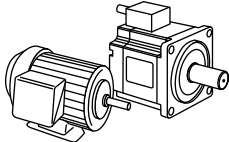
◆ Quick Reference

Easily Set Parameters for Specific Applications	
<p>Preset parameter defaults are available for setting up applications. Refer to Application Selection on page 132.</p>	
Run a Motor One Frame Larger	
<p>This drive can operate a motor one frame size larger when running variable torque loads such as fans and pumps. Refer to C6-01: Drive Duty Mode Selection on page 205.</p>	
Drive a Synchronous PM Motor	
<p>The drive can operate synchronous PM motors. Refer to Subchart A-3: Operation with Permanent Magnet Motors on page 130. ^{<99>}</p>	
<p><99> PM motor control modes are not available on 600 V class drives, models 5A□□□□.</p>	
Perform Auto-Tuning	
<p>Automatic tuning sets motor parameters. Refer to Auto-Tuning on page 135.</p>	
Maintenance Check Using Drive Monitors	
<p>Use drive monitors to check if fans, capacitors, or other components require maintenance. Refer to Performance Life Monitors Maintenance Monitors on page 403.</p>	
Fault Display and Troubleshooting	
<p>Refer to Drive Alarms, Faults, and Errors on page 342 and Refer to Troubleshooting without Fault Display on page 388.</p>	
Standards Compliance	
<p>Refer to European Standards on page 648 and Refer to UL and CSA Standards on page 656 ^{<1>}.</p>	

<1> CE marking applies to 200 V class and 400 V class models only.

This Page Intentionally Blank

Table of Contents

QUICK REFERENCE	3
i. PREFACE & GENERAL SAFETY	17
i.1 Preface	18
Applicable Documentation.....	18
Symbols.....	18
Terms and Abbreviations	19
Trademarks	19
i.2 General Safety	20
Supplemental Safety Information	20
Safety Messages.....	21
General Application Precautions	23
Motor Application Precautions.....	25
Drive Label Warning Example.....	27
Warranty Information.....	27
1. RECEIVING	29
1.1 Section Safety.....	30
1.2 General Description	31
A1000 Model Selection	31
Control Mode Selection	32
1.3 Model Number and Nameplate Check	35
Nameplate	35
1.4 Drive Models and Enclosure Types.....	39
1.5 Component Names.....	42
IP20/NEMA Type 1 Enclosure.....	42
IP00/Open Type Enclosure	45
Front Views	50
2. MECHANICAL INSTALLATION.....	51
2.1 Section Safety.....	52
2.2 Mechanical Installation	54
Installation Environment.....	54
Installation Orientation and Spacing.....	54
Precautions and Instructions for Installation of Models 4A0930 and 4A1200	56
Digital Operator Remote Usage	57
Exterior and Mounting Dimensions	60

3. ELECTRICAL INSTALLATION	69
3.1 Section Safety.....	70
3.2 Standard Connection Diagram.....	72
3.3 Main Circuit Connection Diagram.....	75
Three-Phase 200 V Class Models 2A0004 to 2A0081	
Three-Phase 400 V Class Models 4A0002 to 4A0044	
Three-Phase 600 V Class Models 5A0003 to 5A0032	75
Three-Phase 200 V Class Models 2A0110, 2A0138	
Three-Phase 400 V Class Models 4A0058, 4A0072	
Three-Phase 600 V Class Models 5A0041, 5A0052	75
Three-Phase 200 V Class Models 2A0169 to 2A0211	
Three-Phase 400 V Class Models 4A0088 to 4A0139	
Three-Phase 600 V Class Models 5A0062 to 5A0099	76
Three-Phase 200 V Class Models 2A0250 to 2A0415	
Three-Phase 400 V Class Models 4A0165 to 4A0675	
Three-Phase 600 V Class Models 5A0125 to 5A0242	76
Three-Phase 400 V Class Models 4A0930, 4A1200.....	77
12-Phase Rectification	77
3.4 Terminal Block Configuration	79
3.5 Terminal Cover	81
Models 2A0004 to 2A0081, 4A0002 to 4A0044, 5A0003 to 5A0032 (IP20/NEMA Type 1 Enclosure).....	81
Models 2A0110 to 2A0250, 4A0208 to 4A1200, and 5A0125 to 5A0242 (IP00/Open Type Enclosure).....	82
3.6 Digital Operator and Front Cover.....	83
Removing/Reattaching the Digital Operator.....	83
Removing/Reattaching the Front Cover	83
3.7 Top Protective Cover	86
Removing the Top Protective Cover	86
Reattaching the Top Protective Cover	86
3.8 Main Circuit Wiring.....	87
Main Circuit Terminal Functions.....	87
Protecting Main Circuit Terminals	88
Wire Gauges and Tightening Torque	89
Main Circuit Terminal and Motor Wiring	96
3.9 Control Circuit Wiring	98
Control Circuit Connection Diagram.....	98
Control Circuit Terminal Block Functions	98
Terminal Configuration	100
Wiring the Control Circuit Terminal	101
Switches and Jumpers on the Terminal Board.....	103
3.10 Control I/O Connections	104
Sinking/Sourcing Mode Switch for Digital Inputs.....	104
Sinking/Sourcing Mode Selection for Safe Disable Inputs	105
Using the Pulse Train Output	105
Terminal A2 Input Signal Selection	106
Terminal A3 Analog/PTC Input Selection.....	106
Terminal AM/FM Signal Selection	107
MEMOBUS/Modbus Termination	107

3.11	Connect to a PC	108
3.12	External Interlock	109
	Drive Ready.....	109
3.13	Wiring Checklist	110
4.	START-UP PROGRAMMING & OPERATION	113
4.1	Section Safety	114
4.2	Using the Digital Operator	115
	Keys and Displays.....	115
	LCD Display	116
	ALARM (ALM) LED Displays.....	117
	LO/RE LED and RUN LED Indications.....	117
	Menu Structure for Digital Operator	119
4.3	The Drive and Programming Modes	120
	Navigating the Drive and Programming Modes.....	120
	Changing Parameter Settings or Values	121
	Verifying Parameter Changes: Verify Menu	123
	Simplified Setup Using the Setup Group.....	124
	Switching Between LOCAL and REMOTE.....	125
4.4	Start-Up Flowcharts	126
	Flowchart A: Basic Start-Up and Motor Tuning	127
	Subchart A-1: Simple Motor Setup Using V/f Control.....	128
	Subchart A-2: High Performance Operation Using OLV or CLV	129
	Subchart A-3: Operation with Permanent Magnet Motors.....	130
4.5	Powering Up the Drive	131
	Powering Up the Drive and Operation Status Display.....	131
4.6	Application Selection	132
	Setting 1: Water Supply Pump Application.....	132
	Setting 2: Conveyor Application	133
	Setting 3: Exhaust Fan Application	133
	Setting 4: HVAC Fan Application	134
	Setting 5: Compressor Application	134
4.7	Auto-Tuning	135
	Types of Auto-Tuning	135
	Before Auto-Tuning the Drive.....	138
	Auto-Tuning Interruption and Fault Codes	139
	Auto-Tuning Operation Example	139
	T1: Parameter Settings during Induction Motor Auto-Tuning	141
	Parameter Settings during PM Motor Auto-Tuning: T2	143
	Parameter Settings during Inertia and Speed Control Loop Auto-Tuning: T3.....	146
4.8	No-Load Operation Test Run	148
	No-Load Operation Test Run	148
4.9	Test Run with Load Connected	150
	Test Run with the Load Connected	150
4.10	Verifying Parameter Settings and Backing Up Changes	151
	Backing Up Parameter Values: o2-03	151
	Parameter Access Level: A1-01	151
	Password Settings: A1-04, A1-05	151
	Copy Function	152

4.11 Test Run Checklist	153
5. PARAMETER DETAILS	155
5.1 A: Initialization	156
A1: Initialization	156
A2: User Parameters	161
5.2 b: Application.....	162
b1: Operation Mode Selection	162
b2: DC Injection Braking and Short Circuit Braking.....	170
b3: Speed Search.....	173
b4: Delay Timers	178
b5: PID Control.....	179
b6: Dwell Function.....	188
b7: Droop Control (CLV, CLV/PM)	189
b8: Energy Saving	190
b9: Zero Servo.....	192
5.3 C: Tuning.....	193
C1: Acceleration and Deceleration Times	193
C2: S-Curve Characteristics	195
C3: Slip Compensation.....	195
C4: Torque Compensation	198
C5: Automatic Speed Regulator (ASR).....	200
C6: Carrier Frequency	205
5.4 d: Reference Settings	208
d1: Frequency Reference.....	208
d2: Frequency Upper/Lower Limits	210
d3: Jump Frequency.....	211
d4: Frequency Reference Hold and Up/Down 2 Function.....	212
d5: Torque Control	217
d6: Field Weakening and Field Forcing.....	221
d7: Offset Frequency.....	222
5.5 E: Motor Parameters	223
E1: V/f Pattern for Motor 1.....	223
E2: Motor 1 Parameters	227
E3: V/f Pattern for Motor 2.....	230
E4: Motor 2 Parameters	231
E5: PM Motor Settings	233
5.6 F: Option Settings	236
F1: PG Speed Control Card Settings	236
F2: Analog Input Card Settings	239
F3: Digital Input Card Settings	239
F4: Analog Monitor Card Settings	240
F5: Digital Output Card Settings.....	241
F6: Communication Option Card.....	242
CC-Link Parameters.....	243
PROFIBUS-DP Parameters	244
CANopen Parameters	244
DeviceNet Parameters	245
5.7 H: Terminal Functions.....	247
H1: Multi-Function Digital Inputs	247

H2: Multi-Function Digital Outputs.....	258
H3: Multi-Function Analog Inputs	268
H4: Multi-Function Analog Outputs	274
H5: MEMOBUS/Modbus Serial Communication	276
H6: Pulse Train Input/Output.....	276
5.8 L: Protection Functions	279
L1: Motor Protection	279
L2: Momentary Power Loss Ride-Thru.....	286
L3: Stall Prevention	293
L4: Speed Detection.....	299
L5: Fault Restart.....	301
L6: Torque Detection.....	302
L7: Torque Limit	305
L8: Drive Protection.....	306
5.9 n: Special Adjustments.....	313
n1: Hunting Prevention.....	313
n2: Speed Feedback Detection Control (AFR) Tuning.....	314
n3: High Slip Braking (HSB) and Overexcitation Braking.....	314
n5: Feed Forward Control	317
n6: Online Tuning	319
n8: PM Motor Control Tuning	319
5.10 o: Operator Related Settings.....	324
o1: Digital Operator Display Selection.....	324
o2: Digital Operator Keypad Functions	325
o3: Copy Function	327
o4: Maintenance Monitor Settings.....	328
q: DriveWorksEZ Parameters.....	330
r: DriveWorksEZ Connection Parameters	330
T: Motor Tuning.....	330
5.11 U: Monitor Parameters	331
U1: Operation Status Monitors	331
U2: Fault Trace.....	331
U3: Fault History.....	331
U4: Maintenance Monitors	331
U5: PID Monitors	331
U6: Operation Status Monitors	331
U8: DriveWorksEZ Monitors.....	332
6. TROUBLESHOOTING.....	333
6.1 Section Safety.....	334
6.2 Motor Performance Fine-Tuning.....	336
Fine-Tuning V/f Control and V/f Control with PG.....	336
Fine-Tuning Open Loop Vector Control	337
Fine-Tuning Closed Loop Vector Control	338
Fine-Tuning Open Loop Vector Control for PM Motors.....	339
Fine-Tuning Advanced Open Loop Vector Control for PM Motors.....	340
Fine-Tuning Closed Loop Vector Control for PM Motors	340
Parameters to Minimize Motor Hunting and Oscillation	341
6.3 Drive Alarms, Faults, and Errors	342
Types of Alarms, Faults, and Errors.....	342

Alarm and Error Displays	343
6.4 Fault Detection	347
Fault Displays, Causes, and Possible Solutions	347
6.5 Alarm Detection	366
Alarm Codes, Causes, and Possible Solutions	366
6.6 Operator Programming Errors	375
Operator Programming Error Codes, Causes, and Possible Solutions.....	375
6.7 Auto-Tuning Fault Detection	379
Auto-Tuning Codes, Causes, and Possible Solutions.....	379
6.8 Copy Function Related Displays	384
Tasks, Errors, and Troubleshooting	384
6.9 Diagnosing and Resetting Faults.....	386
Fault Occurs Simultaneously with Power Loss	386
If the Drive Still has Power After a Fault Occurs	386
Viewing Fault Trace Data After Fault	386
Fault Reset Methods	387
6.10 Troubleshooting without Fault Display	388
Common Problems.....	388
Cannot Change Parameter Settings	388
Motor Does Not Rotate Properly after Pressing RUN Button or after Entering External Run Command	389
Motor is Too Hot.....	390
Drive Does Not Allow Selection of the Desired Auto-Tuning Mode.....	391
oPE02 Error Occurs When Lowering the Motor Rated Current Setting	391
Motor Stalls during Acceleration or Acceleration Time is Too Long.....	391
Drive Frequency Reference Differs from the Controller Frequency Reference Command	392
Excessive Motor Oscillation and Erratic Rotation.....	392
Deceleration Takes Longer Than Expected with Dynamic Braking Enabled	392
Noise From Drive or Motor Cables When the Drive is Powered On	393
Ground Fault Circuit Interrupter (GFCI) Trips During Run	393
Connected Machinery Vibrates When Motor Rotates	393
PID Output Fault.....	394
Insufficient Starting Torque	394
Motor Rotates After the Drive Output is Shut Off (Motor Rotates During DC Injection Braking).....	394
Output Frequency is Not as High as Frequency Reference.....	394
Sound from Motor.....	394
Unstable Motor Speed when Using PM	395
Motor Does Not Restart after Power Loss.....	395
7. PERIODIC INSPECTION & MAINTENANCE	397
7.1 Section Safety.....	398
7.2 Inspection	400
Recommended Daily Inspection.....	400
Recommended Periodic Inspection.....	401
7.3 Periodic Maintenance	403
Replacement Parts.....	403
7.4 Drive Cooling Fans.....	405
Number of Cooling Fans	405
Cooling Fan Component Names.....	407

Cooling Fan Replacement: 2A0018 to 2A0081, 4A0007 to 4A0044, and 5A0006 to 5A0032	409
Cooling Fan Replacement: 2A0110, 2A0138, 4A0058, 4A0072, 5A0041, and 5A0052	411
Cooling Fan Replacement: 4A0088 and 4A0103	413
Cooling Fan Replacement: 2A0169 to 2A0415, 4A0139 to 4A0362, and 5A0062 to 5A0242	415
Cooling Fan Replacement: 4A0414	419
Cooling Fan Replacement: 4A0515 and 4A0675	421
Cooling Fan Replacement: 4A0930 and 4A1200	425
7.5 Replacing the Air Filter	430
Air Filter Replacement	430
7.6 Drive Replacement	432
Serviceable Parts	432
Terminal Board	432
Replacing the Drive	433
8. PERIPHERAL DEVICES & OPTIONS	435
8.1 Section Safety	436
8.2 Drive Options and Peripheral Devices	437
8.3 Connecting Peripheral Devices	439
8.4 Option Installation	440
Prior to Installing the Option	440
PG Option Installation Example	441
Terminal Functions of PG-B3 and PG-X3 Options	448
8.5 Installing Peripheral Devices	449
Dynamic Braking Options	449
Installing a Molded Case Circuit Breaker (MCCB) or Ground Fault Circuit Interrupter (GFCI)	452
Installing a Magnetic Contactor at the Power Supply Side	452
Connecting an AC Reactor or DC Link Choke	453
Connecting a Surge Absorber	453
Connecting a Noise Filter	454
Installing Input Fuses	455
Attachment for External Heatsink Mounting	459
Installing a Motor Thermal Overload (oL) Relay on the Drive Output	459
A. SPECIFICATIONS	461
A.1 Heavy Duty and Normal Duty Ratings	462
A.2 Power Ratings	463
Three-Phase 200 V Class Drive Models 2A0004 to 2A0030	463
Three-Phase 200 V Class Drive Models 2A0040 to 2A0211	464
Three-Phase 200 V Class Drive Models 2A0250 to 2A0415	465
Three-Phase 400 V Class Drive Models 4A0002 to 4A0031	466
Three-Phase 400 V Class Drive Models 4A0038 to 4A0165	467
Three-Phase 400 V Class Drive Models 4A0208 to 4A1200	468
Three-Phase 600 V Class Drive Models 5A0003 to 5A0032	469
Three-Phase 600 V Class Drive Models 5A0041 to 5A0099	470
Three-Phase 600 V Class Drive Models 5A0125 to 5A0242	471
A.3 Drive Specifications	472
A.4 Drive Watt Loss Data	474
A.5 Drive Derating Data	476
Single-Phase Derating	476

Carrier Frequency Derating	482
Temperature Derating	486
Altitude Derating	487
B. PARAMETER LIST	489
B.1 Understanding Parameter Descriptions	490
Control Modes, Symbols, and Terms	490
B.2 Parameter Groups	491
Parameter Differences for Drive Models 4A0930 and 4A1200	492
B.3 A: Initialization Parameters	493
A1: Initialization	493
A2: User Parameters	494
B.4 b: Application	495
b1: Operation Mode Selection	495
b2: DC Injection Braking and Short Circuit Braking	496
b3: Speed Search	497
b4: Timer Function	498
b5: PID Control	499
b6: Dwell Function	501
b7: Droop Control	501
b8: Energy Saving	501
b9: Zero Servo	502
B.5 C: Tuning	503
C1: Acceleration and Deceleration Times	503
C2: S-Curve Characteristics	504
C3: Slip Compensation	504
C4: Torque Compensation	505
C5: Automatic Speed Regulator (ASR)	506
C6: Carrier Frequency	508
B.6 d: References	509
d1: Frequency Reference	509
d2: Frequency Upper/Lower Limits	510
d3: Jump Frequency	511
d4: Frequency Reference Hold and Up/Down 2 Function	511
d5: Torque Control	512
d6: Field Weakening and Field Forcing	513
d7: Offset Frequency	513
B.7 E: Motor Parameters	514
E1: V/f Pattern for Motor 1	514
E2: Motor 1 Parameters	515
E3: V/f Pattern for Motor 2	516
E4: Motor 2 Parameters	517
E5: PM Motor Settings	518
B.8 F: Options	520
F1: PG Speed Control Card (PG-X3/PG-B3)	520
F2: Analog Input Card (AI-A3)	522
F3: Digital Input Card (DI-A3)	522
F4: Analog Monitor Card (AO-A3)	523
F5: Digital Output Card (DO-A3)	523
F6, F7: Communication Option Card	524

B.9 H Parameters: Multi-Function Terminals	528
H1: Multi-Function Digital Inputs	528
H2: Multi-Function Digital Outputs.....	533
H3: Multi-Function Analog Inputs	536
H4: Analog Outputs	538
H5: MEMOBUS/Modbus Serial Communication	539
H6: Pulse Train Input/Output.....	540
B.10 L: Protection Function	541
L1: Motor Protection	541
L2: Momentary Power Loss Ride-Thru.....	542
L3: Stall Prevention	543
L4: Speed Detection.....	545
L5: Fault Restart.....	545
L6: Torque Detection.....	546
L7: Torque Limit	547
L8: Drive Protection.....	547
B.11 n: Special Adjustment.....	550
n1: Hunting Prevention.....	550
n2: Speed Feedback Detection Control (AFR) Tuning.....	550
n3: High Slip Braking (HSB) and Overexcitation Braking.....	550
n5: Feed Forward Control	551
n6: Online Tuning	552
n8: PM Motor Control Tuning	552
B.12 o: Operator-Related Settings	554
o1: Digital Operator Display Selection.....	554
o2: Digital Operator Keypad Functions	554
o3: Copy Function	555
o4: Maintenance Monitor Settings.....	555
B.13 DriveWorksEZ Parameters	557
q: DriveWorksEZ Parameters.....	557
r: DriveWorksEZ Connection Parameters	557
B.14 T: Motor Tuning	558
T1: Induction Motor Auto-Tuning.....	558
T2: PM Motor Auto-Tuning	559
T3: ASR and Inertia Tuning.....	561
B.15 U: Monitors.....	562
U1: Operation Status Monitors	562
U2: Fault Trace.....	564
U3: Fault History.....	566
U4: Maintenance Monitors	566
U5: PID Monitors	568
U6: Operation Status Monitors	569
U8: DriveWorksEZ Monitors.....	570
B.16 Control Mode Dependent Parameter Default Values	571
A1-02 (Motor 1 Control Mode) Dependent Parameters	571
E3-01 (Motor 2 Control Mode) Dependent Parameters	574
B.17 V/f Pattern Default Values.....	575
B.18 Defaults by Drive Model and Duty Rating ND/HD.....	577
B.19 Parameters Changed by Motor Code Selection	594

Yaskawa SMRA Series SPM Motor	594
Yaskawa SSR1 Series IPM Motor (For Derated Torque).....	595
Yaskawa SST4 Series IPM Motor (For Constant Torque)	602
C. MEMOBUS/MODBUS COMMUNICATIONS.....	611
C.1 MEMOBUS/Modbus Configuration	612
C.2 Communication Specifications	613
C.3 Connecting to a Network	614
Network Cable Connection.....	614
Wiring Diagram for Multiple Connections	614
Network Termination	615
C.4 MEMOBUS/Modbus Setup Parameters	616
MEMOBUS/Modbus Serial Communication.....	616
C.5 Drive Operations by MEMOBUS/Modbus.....	619
Observing the Drive Operation.....	619
Controlling the Drive.....	619
C.6 Communications Timing.....	620
Command Messages from Master to Drive.....	620
Response Messages from Drive to Master	620
C.7 Message Format	621
Message Content	621
Slave Address	621
Function Code	621
Data.....	621
Error Check	621
C.8 Message Examples	623
Reading Drive MEMOBUS/Modbus Register Contents	623
Loopback Test.....	623
Writing to Multiple Registers.....	624
C.9 MEMOBUS/Modbus Data Table.....	625
Command Data	625
Monitor Data.....	626
Broadcast Messages.....	637
Fault Trace Contents.....	638
Alarm Register Contents	640
C.10 Enter Command.....	641
Enter Command Types	641
Enter Command Settings when Upgrading the Drive.....	641
C.11 Communication Errors	642
MEMOBUS/Modbus Error Codes.....	642
Slave Not Responding.....	642
C.12 Self-Diagnostics	643
D. STANDARDS COMPLIANCE	645
D.1 Section Safety.....	646
D.2 European Standards	648
CE Low Voltage Directive Compliance.....	648
EMC Guidelines Compliance	650

D.3 UL and CSA Standards	656
UL Standards Compliance	656
CSA Standards Compliance.....	671
Drive Motor Overload Protection	671
Precautionary Notes on External Heatsink (IP00/Open Type Enclosure)	673
D.4 Safe Disable Input Function	675
Specifications	675
Precautions	675
Using the Safe Disable Function	675
E. QUICK REFERENCE SHEET	679
E.1 Drive and Motor Specifications.....	680
Drive Specifications.....	680
Motor Specifications	680
E.2 Basic Parameter Settings	682
Basic Setup	682
V/f Pattern Setup	682
Motor Setup.....	682
Multi-Function Digital Inputs	683
Pulse Train Input/Analog Inputs	683
Multi-Function Digital Outputs	683
Monitor Outputs.....	683
E.3 User Setting Table	684
INDEX	693

This Page Intentionally Blank

Preface & General Safety

This section provides safety messages pertinent to this product that, if not heeded, may result in fatality, personal injury, or equipment damage. Yaskawa is not responsible for the consequences of ignoring these instructions.

i.1	PREFACE.....	18
i.2	GENERAL SAFETY.....	20

i.1 Preface

Yaskawa manufactures products used as components in a wide variety of industrial systems and equipment. The selection and application of Yaskawa products remain the responsibility of the equipment manufacturer or end user. Yaskawa accepts no responsibility for the way its products are incorporated into the final system design. Under no circumstances should any Yaskawa product be incorporated into any product or design as the exclusive or sole safety control. Without exception, all controls should be designed to detect faults dynamically and fail safely under all circumstances. All systems or equipment designed to incorporate a product manufactured by Yaskawa must be supplied to the end user with appropriate warnings and instructions as to the safe use and operation of that part. Any warnings provided by Yaskawa must be promptly provided to the end user. Yaskawa offers an express warranty only as to the quality of its products in conforming to standards and specifications published in the Yaskawa manual. **NO OTHER WARRANTY, EXPRESS OR IMPLIED, IS OFFERED.** Yaskawa assumes no liability for any personal injury, property damage, losses, or claims arising from misapplication of its products.

This manual is designed to ensure correct and suitable application of A1000-Series Drives. Read this manual before attempting to install, operate, maintain, or inspect a drive and keep it in a safe, convenient location for future reference. Be sure you understand all precautions and safety information before attempting application.

◆ Applicable Documentation

The following manuals are available for A1000 series drives:

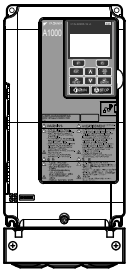
	A1000 Series AC Drive Technical Manual (SIEPC71061641)
	This manual provides detailed information on parameter settings, drive functions, and MEMOBUS/Modbus specifications. Use this manual to expand drive functionality and to take advantage of higher performance features. This manual is available for download on our documentation website, www.yaskawa.com .
	A1000 Series AC Drive Quick Start Guide (TOEPC71061641)
	Read this guide first. This guide is packaged together with the product and contains basic information required to install and wire the drive. It also gives an overview of fault diagnostics, maintenance, and parameter settings. The purpose of this guide is to prepare the drive for a trial run with an application and for basic operation. This manual is available for download on our documentation website, www.yaskawa.com .

◆ Symbols

Note: Indicates a supplement or precaution that does not cause drive damage.



Indicates a term or definition used in this manual.

◆ Terms and Abbreviations



- **Drive:** Yaskawa A1000-Series Drive
- **BCD:** Binary Coded Decimal
- **H:** Hexadecimal Number Format
- **IGBT:** Insulated Gate Bipolar Transistor
- **kbps:** Kilobits per Second
- **MAC:** Media Access Control
- **Mbps:** Megabits per Second
- **PG:** Pulse Generator
- **r/min:** Revolutions per Minute
- **V/f:** V/f Control
- **V/f w/PG:** V/f Control with PG
- **OLV:** Open Loop Vector Control
- **CLV:** Closed Loop Vector Control
- **OLV/PM:** Open Loop Vector Control for PM
- **AOLV/PM:** Advanced Open Loop Vector Control for PM
- **CLV/PM:** Closed Loop Vector Control for PM
- **PM motor:** Permanent Magnet Synchronous motor (an abbreviation for IPM motor or SPM motor)
- **IPM motor:** Interior Permanent Magnet Motor (e.g., Yaskawa SSR1 Series and SST4 Series motors)
- **SPM motor:** Surface mounted Permanent Magnet Motor (e.g., Yaskawa SMRA Series motors)

◆ Trademarks

- CANopen is a trademark of CAN in Automation (CiA).
- CC-Link is a trademark of CC-Link Partner Association (CLPA).
- DeviceNet is a trademark of Open DeviceNet Vendor Association, Inc. (ODVA).
- PROFIBUS-DP is a trademark of PROFIBUS International (PI).
- MECHATROLINK-I/MECHATROLINK-II are trademarks of MECHATROLINK Members Association (MMA).
- Other companies and product names mentioned in this manual are trademarks of those companies.

i.2 General Safety

◆ Supplemental Safety Information

General Precautions

- The diagrams in this manual may be indicated without covers or safety shields to show details. Replace the covers or shields before operating the drive and run the drive according to the instructions described in this manual.
- Any illustrations, photographs, or examples used in this manual are provided as examples only and may not apply to all products to which this manual is applicable.
- The products and specifications described in this manual or the content and presentation of the manual may be changed without notice to improve the product and/or the manual.
- When ordering a new copy of the manual due to damage or loss, contact your Yaskawa representative or the nearest Yaskawa sales office and provide the manual number shown on the front cover.
- If nameplate becomes worn or damaged, order a replacement from your Yaskawa representative or the nearest Yaskawa sales office.

WARNING

Read and understand this manual before installing, operating or servicing this drive. The drive must be installed according to this manual and local codes.

The following conventions are used to indicate safety messages in this manual. Failure to heed these messages could result in serious or fatal injury or damage to the products or to related equipment and systems.

DANGER

Indicates a hazardous situation, which, if not avoided, will result in death or serious injury.

WARNING

Indicates a hazardous situation, which, if not avoided, could result in death or serious injury.

WARNING! may also be indicated by a bold key word embedded in the text followed by an italicized safety message.

CAUTION

Indicates a hazardous situation, which, if not avoided, could result in minor or moderate injury.

CAUTION! may also be indicated by a bold key word embedded in the text followed by an italicized safety message.

NOTICE

Indicates a property damage message.

NOTICE: may also be indicated by a bold key word embedded in the text followed by an italicized safety message.

◆ Safety Messages

DANGER

Heed the safety messages in this manual.

Failure to comply will result in death or serious injury.

The operating company is responsible for any injuries or equipment damage resulting from failure to heed the warnings in this manual.

Electrical Shock Hazard

Do not connect or disconnect wiring while the power is on.

Failure to comply will result in death or serious injury.

Before servicing, disconnect all power to the equipment. The internal capacitor remains charged even after the power supply is turned off. After shutting off the power, wait for at least the amount of time specified on the drive before touching any components.

WARNING

Sudden Movement Hazard

System may start unexpectedly upon application of power, resulting in death or serious injury.

Clear all personnel from the drive, motor and machine area before applying power. Secure covers, couplings, shaft keys and machine loads before applying power to the drive.

When using DriveWorksEZ to create custom programming, the drive I/O terminal functions change from factory settings and the drive will not perform as outlined in this manual.

Unpredictable equipment operation may result in death or serious injury.

Take special note of custom I/O programming in the drive before attempting to operate equipment.

Electrical Shock Hazard

Do not attempt to modify or alter the drive in any way not explained in this manual.

Failure to comply could result in death or serious injury.

Yaskawa is not responsible for any modification of the product made by the user. This product must not be modified.

Do not allow unqualified personnel to use equipment.

Failure to comply could result in death or serious injury.

Maintenance, inspection, and replacement of parts must be performed only by authorized personnel familiar with installation, adjustment and maintenance of AC drives.

Do not remove covers or touch circuit boards while the power is on.

Failure to comply could result in death or serious injury.

Make sure the protective earthing conductor complies with technical standards and local safety regulations.

Because the leakage current exceeds 3.5 mA in models 4A0414 and larger, IEC 61800-5-1 states that either the power supply must be automatically disconnected in case of discontinuity of the protective earthing conductor or a protective earthing conductor with a cross-section of at least 10 mm² (Cu) or 16 mm² (Al) must be used. Failure to comply may result in death or serious injury.

Always use appropriate equipment for Ground Fault Circuit Interrupters (GFCIs).

The drive can cause a residual current with a DC component in the protective earthing conductor. Where a residual current operated protective or monitoring device is used for protection in case of direct or indirect contact, always use a type B GFCI according to IEC 60755.

Fire Hazard

Do not use an improper voltage source.

Failure to comply could result in death or serious injury by fire.

Verify that the rated voltage of the drive matches the voltage of the incoming power supply before applying power.

WARNING

Install adequate branch circuit protection according to applicable local codes and this Installation Manual. Failure to comply could result in fire and damage to the A1000 drive or injury to personnel.

The device is suitable for use on a circuit capable of delivering not more than 100,000 RMS symmetrical amperes, 240 Vac maximum (200 V class) and 480 Vac maximum (400 V class), and 600 Vac maximum (600 V class) when protected by branch circuit protection devices specified in this supplement.

Crush Hazard

Do not use this drive in lifting applications without installing external safety circuitry to prevent accidental dropping of the load.

The drive does not possess built-in load drop protection for lifting applications.

Failure to comply could result in death or serious injury from falling loads.

Install electrical and/or mechanical safety circuit mechanisms independent of drive circuitry.

CAUTION

Crush Hazard

Do not carry the drive by the front cover.

Failure to comply may result in minor or moderate injury from the main body of the drive falling.

NOTICE

Observe proper electrostatic discharge procedures (ESD) when handling the drive and circuit boards.

Failure to comply may result in ESD damage to the drive circuitry.

Do not perform a withstand voltage test on any part of the drive.

Failure to comply could result in damage to the sensitive devices within the drive.

Do not operate damaged equipment.

Failure to comply could result in further damage to the equipment.

Do not connect or operate any equipment with visible damage or missing parts.

If a fuse is blown or a Ground Fault Circuit Interrupter (GFCI) is tripped, check the wiring and the selection of the peripheral devices.

Contact your supplier if the cause cannot be identified after checking the above.

Do not restart the drive immediately operate the peripheral devices if a fuse is blown or a GFCI is tripped.

Check the wiring and the selection of peripheral devices to identify the cause. Contact your supplier before restarting the drive or the peripheral devices if the cause cannot be identified.

Install adequate branch circuit short circuit protection per applicable codes.

Failure to comply could result in damage to the drive.

The drive is suitable for use on a circuit capable of delivering not more than 100,000 RMS symmetrical Amperes, 240 Vac maximum (200 V Class), 480 Vac maximum (400 V Class), and 600 Vac maximum (600 V Class) when protected by Bussmann Type FWH or FWP fuses as specified in *Factory Recommended Branch Circuit Protection* on page 648.

Do not expose the drive to halogen group disinfectants.

Failure to comply may cause damage to the electrical components in the drive.

Do not pack the drive in wooden materials that have been fumigated or sterilized.

Do not sterilize the entire package after the product is packed.

◆ General Application Precautions

■ Selection

Installing a Reactor

Use an AC reactor or DC link choke in the following situations:

- to suppress harmonic current.
- to smooth peak current that results from capacitor switching.
- when the power supply is above 600 kVA.
- when the drive is running from a power supply system with thyristor converters.

Note: A DC link choke is built in to drive models 2A0110 to 2A0415 and 4A0058 to 4A1200.

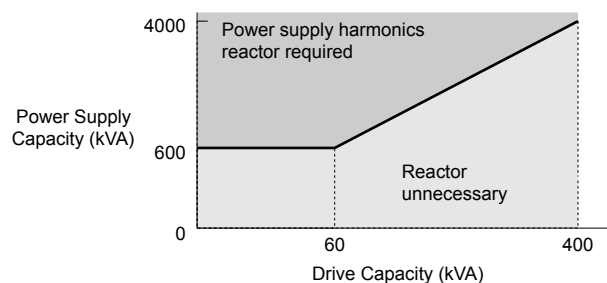

Figure i.1 Installing a Reactor

Drive Capacity

For specialized motors, make sure that the motor rated current is less than the rated output current for the drive.

When running more than one motor in parallel from a single drive, the capacity of the drive should be larger than [total motor rated current \times 1.1].

Starting Torque

The overload rating for the drive determines the starting and accelerating characteristics of the motor. Expect lower torque than when running from line power. To get more starting torque, use a larger drive or increase both the motor and drive capacity.

Emergency Stop

During a drive fault condition, the output shuts off but the motor does not stop immediately. A mechanical brake may be required when it is necessary to stop the motor faster than the ability of the Fast Stop function of the drive.

Options

NOTICE: The B1, B2, -, +1, +2, and +3 terminals are used to connect optional drive-specific compatible devices only. Connecting non-Yaskawa-approved devices to these terminals may damage the drive.

Repetitive Starting/Stopping

Laundry machines, punching presses, and other applications with frequent starts and stops often approach 150% of their rated current values. Heat stress generated from repetitive high current will shorten the life span of the IGBTs.

Yaskawa recommends lowering the carrier frequency, particularly when audible noise is not a concern. It is beneficial to reduce the load, increase the acceleration and deceleration times, or switch to a larger drive to help keep peak current levels under 150%. Be sure to check the peak current levels when starting and stopping repeatedly during the initial test run, and make adjustments accordingly.

■ Installation

Enclosure Panels

Keep the drive in a clean environment by installing the drive in an enclosure panel or selecting an installation area free of airborne dust, lint, and oil mist. Be sure to leave the required space between drives to provide for cooling, and take proper measures so the ambient temperature remains within allowable limits and keep flammable materials away from the drive. Yaskawa offers protective designs for drives that must be used in areas subjected to oil mist and excessive vibration. Contact Yaskawa or your Yaskawa agent for details.

Installation Direction

NOTICE: Install the drive upright as specified in the manual. [Refer to Mechanical Installation on page 54](#) for more information on installation. Failure to comply may damage the drive due to improper cooling.

i.2 General Safety

■ Settings

Motor Code

When using OLV/PM, set the proper motor code to parameter E5-01 before performing a trial run.

Upper Limits

NOTICE: *The drive is capable of running the motor up to 400 Hz. Be sure to set the upper limit for the frequency of the drive to prevent the possible danger of accidentally operating equipment at higher than rated speed. The default setting for the maximum output frequency is 60 Hz.*

DC Injection Braking

NOTICE: *Excessive current during DC Injection Braking and excessive duration of DC Injection Braking can cause motor overheat.*

Acceleration/Deceleration Times

Acceleration and deceleration times are affected by the amount of torque generated by the motor, the load torque, and the inertia moment. Set a longer accel/decel time when Stall Prevention is enabled. The accel/decel times are lengthened for as long as the Stall Prevention function is in operation. Install one of the available braking options or increase the capacity of the drive for faster acceleration and deceleration.

■ General Handling

Wiring Check

NOTICE: *Do not connect power supply lines to output terminals U/T1, V/T2, or W/T3. Failure to comply will destroy the drive. Be sure to perform a final check of all sequence wiring and other connections before turning on the power and also check for short circuits on the control terminals, which may damage the drive.*

Selecting a Circuit Breaker or Circuit Interrupter

Yaskawa recommends installing a Ground Fault Circuit Interrupter (GFCI) to the power supply side. The GFCI should be designed for use with AC drives (e.g., Type B according to IEC 60755).

Select a Molded Case Circuit Breaker (MCCB) or GFCI with a rated current 1.5 to 2 times higher than the drive rated current to avoid nuisance trips caused by harmonics in the drive input current. [Refer to *Installing a Molded Case Circuit Breaker \(MCCB\) or Ground Fault Circuit Interrupter \(GFCI\)* on page 452](#) for more information.

NOTICE: *Prevent Equipment Damage. Install a fuse and a GFCI in models 4A0930 and 4A1200. Failure to comply may result in serious damage to the facilities if the drive is defective. [Refer to *Wiring Fuses for Models 4A0930 and 4A1200* on page 88](#) for details.*

Magnetic Contactor Installation

WARNING! Fire Hazard. *Shut off the drive with a magnetic contactor (MC) when a fault occurs in any external equipment such as braking resistors. [Refer to *Installing a Magnetic Contactor at the Power Supply Side* on page 452](#). Failure to comply may cause resistor overheating, fire, and injury to personnel.*

NOTICE: *To get the full performance life out of the electrolytic capacitors and circuit relays, refrain from switching the drive power supply off and on more than once every 30 minutes. Frequent use can damage the drive. Use the drive to stop and start the motor.*

Inspection and Maintenance

WARNING! Electrical Shock Hazard. *Capacitors in the drive do not immediately discharge after shutting off the power. Wait for at least the amount of time specified on the drive before touching any components after shutting off the power. Failure to comply may cause injury to personnel from electrical shock.*

WARNING! Electrical Shock Hazard. *When a drive is running a PM motor, voltage continues to be generated at the motor terminals after the drive is shut off while the motor coasts to stop. Take the precautions described below to prevent shock and injury:*

- *In applications where the machine can still rotate after the drive has fully stopped a load, install a switch to the drive output side to disconnect the motor and the drive.*
- *Do not allow an external force to rotate the motor beyond the maximum allowable speed or to rotate the motor when the drive has been shut off.*
- *Wait for at least the time specified on the warning label after opening the load switch on the output side before inspecting the drive or performing any maintenance.*
- *Do not open and close the load switch while the motor is running.*
- *If the motor is coasting, make sure the power to the drive is turned on and the drive output has completely stopped before closing the load switch.*

WARNING! Burn Hazard. *Because the heatsink can get very hot during operation, take proper precautions to prevent burns. When replacing the cooling fan, shut off the power and wait at least 15 minutes to be sure that the heatsink has cooled down. Failure to comply may cause burn injury to personnel.*

Wiring

Yaskawa recommends using ring terminals on all drive models. Drive models 2A0069 to 2A0415 and 4A0058 to 4A1200 require the use of use ring terminals for UL/cUL compliance. Use only the tools recommended by the terminal manufacturer for crimping.

Transporting the Drive

NOTICE: Never steam clean the drive. During transport, keep the drive from coming into contact with salts, fluorine, bromine, phthalate ester, and other such harmful chemicals.

◆ Motor Application Precautions

■ Standard Induction Motors

Low-Speed Range

The cooling fan of a standard motor should sufficiently cool the motor at the rated speed. As the self-cooling capability of such a motor reduces with the speed, applying full torque at low speed will possibly damage the motor. Reduce the load torque as the motor slows to prevent motor damage from overheating. *Figure i.2* shows the allowable load characteristics for a Yaskawa standard motor. Use a motor designed specifically for operation with a drive when 100% continuous torque is needed at low speeds.

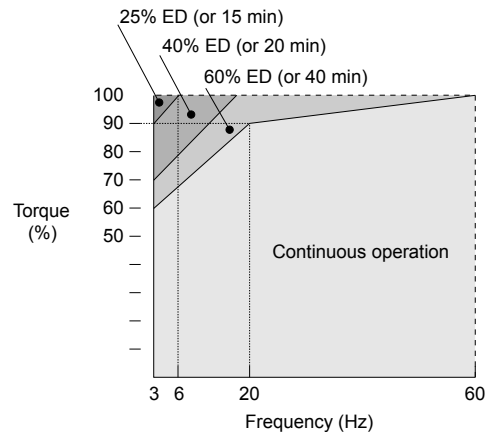

Figure i.2 Allowable Load Characteristics for a Yaskawa Motor

Insulation Tolerance

NOTICE: Consider motor voltage tolerance levels and motor insulation in applications with an input voltage of over 440 V or particularly long wiring distances.

High-Speed Operation

NOTICE: Problems may occur with the motor bearings and dynamic balance of the machine when operating a motor beyond its rated speed. Contact the motor or machine manufacturer.

Torque Characteristics

Torque characteristics differ compared to operating the motor directly from line power. The user should have a full understanding of the load torque characteristics for the application.

Vibration and Shock

The drive allows selection of high carrier PWM control and low carrier PWM. Selecting high carrier PWM can help reduce motor oscillation.

- Take particular caution when adding a variable speed drive to an application running a motor from line power at a constant speed. If resonance occurs, install shock-absorbing rubber around the base of the motor and enable the Jump frequency selection to prevent continuous operation in the resonant frequency range.
- Mechanical resonance can occur with long motor shafts and in applications such as turbines, blowers, and fans with high inertia loads. Use Closed Loop Vector Control when these applications experience mechanical resonance problems.

Audible Noise

Noise created during run varies by the carrier frequency setting. When using a high carrier frequency, audible noise from the motor is comparable to the motor noise generated when running from line power. Operating above the rated motor speed can create unpleasant motor noise.

■ Synchronous Motors

- Contact Yaskawa or a Yaskawa agent when planning to use a synchronous motor not endorsed by Yaskawa.
- Use a standard induction motor when running multiple synchronous motors simultaneously. A single drive does not have this capability.

i.2 General Safety

- A synchronous motor may rotate slightly in the opposite direction of the Run command at start depending on parameter settings and rotor position.
- The amount of generated starting torque differs depending on the control mode and motor type. Set up the motor with the drive after verifying the starting torque, allowable load characteristics, impact load tolerance, and speed control range.
Contact Yaskawa or a Yaskawa agent when planning to use a motor that does not fall within these specifications:
- In Open Loop Vector Control for PM motors, braking torque is less than 125% when running between 20% and 100% speed, even with a braking resistor. Braking torque drops to less than 50% when running at less than 20% speed.
- In Open Loop Vector Control for PM motors, the allowable load inertia moment is approximately 50 times higher than the motor inertia moment.
Contact Yaskawa or a Yaskawa agent for questions concerning applications with a larger inertia moment.
- When using a holding brake in Open Loop Vector Control for PM motors, release the brake prior to starting the motor. Failure to set the proper timing can cause speed loss.
- To restart a coasting motor rotating over 200 Hz while in V/f Control, first use the Short Circuit Braking function to bring the motor to a stop. Short Circuit Braking requires a special braking resistor. Contact Yaskawa or a Yaskawa agent for details.
- To restart a coasting motor rotating below 200 Hz, use the Speed Search function if the motor cable is not too long. If the motor cable is relatively long, stop the motor using Short Circuit Braking.

■ Specialized Motors

Multi-Pole Motor

The rated current of a multi-pole motor differs from that of a standard motor, so be sure to check the maximum current when selecting a drive. Always stop the motor before switching between the number of motor poles. The motor will coast to stop if a regen overvoltage (ov) fault occurs or if overcurrent (oC) protection is triggered.

Submersible Motor

The rated current of a submersible motor is greater than that of a standard motor, so select the drive capacity accordingly. Use a motor cable large enough to avoid decreasing the maximum torque level from voltage drop caused by a long motor cable.

Explosion-Proof Motor

The motor and the drive must be tested together to be certified as explosion-proof. The drive is not designed for explosion-proof areas.

When attaching an encoder to an explosion-proof motor, make sure the encoder is also explosion-proof. Use an insulating signal converter to connect the encoder signal lines to the speed feedback option card.

Geared Motor

Make sure that the gear and the lubricant are rated for the desired speed range to avoid gear damage when operating at low speeds or very high speeds. Consult with the manufacturer for applications that require operation outside the rated speed range of the motor or gear box.

Single-Phase Motor

Variable speed drives are not designed to operate with single phase motors. Using capacitors to start the motor causes excessive current to flow and can damage drive components. A split-phase start or a repulsion start can burn out the starter coils because the internal centrifugal switch is not activated. The drive is for use with three-phase motors only.

Motor with Brake

Take caution when using the drive to operate a motor with a built-in holding brake. If the brake is connected to the output side of the drive, it may not release at start due to low voltage levels, so be sure to install a separate power supply for the motor brake. Note that motors with built-in brakes tend to generate a fair amount of noise when running at low speeds.

■ Notes on Power Transmission Machinery

Installing an AC drive in machinery that was previously connected directly to the power supply will allow the machine to operate at variable speeds. Continuous operation outside of the rated speeds can wear on lubrication material in gear boxes and other power transmission parts. Make sure that lubrication is sufficient within the entire speed range to avoid machine damage. Note that operation above the rated speed can increase the noise generated by the machine.

◆ Drive Label Warning Example

Always heed the warning information listed in *Figure i.3* in the position shown in *Figure i.4*.

⚠ WARNING

⚡ Risk of electric shock.

- Read manual before installing.
- Wait 5 minutes for capacitor discharge after disconnecting power supply.
- To conform to **CE** requirements, make sure to ground the supply neutral for 400V class.
- After opening the manual switch between the drive and motor, please wait 5 minutes before inspecting, performing maintenance or wiring the drive.

🔥 Hot surfaces

- Top and Side surfaces may become hot. Do not touch.

Figure i.3 Warning Information Example

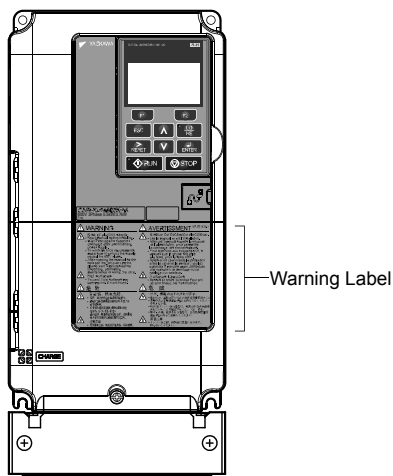

Figure i.4 Warning Information Position

◆ Warranty Information

■ Restrictions

The drive is not designed or manufactured for use in devices or systems that may directly affect or threaten human lives or health.

Customers who intend to use the product described in this manual for devices or systems relating to transportation, health care, space aviation, atomic power, electric power, or in underwater applications must first contact their Yaskawa representatives or the nearest Yaskawa sales office.

WARNING! *Injury to Personnel. This product has been manufactured under strict quality-control guidelines. However, if this product is to be installed in any location where failure of this product could involve or result in a life-and-death situation or loss of human life or in a facility where failure may cause a serious accident or physical injury, safety devices must be installed to minimize the likelihood of any accident.*

This Page Intentionally Blank

Receiving

This chapter explains how to inspect the drive upon receipt, and gives an overview of the different enclosure types and components.

1.1	SECTION SAFETY.....	30
1.2	GENERAL DESCRIPTION.....	31
1.3	MODEL NUMBER AND NAMEPLATE CHECK.....	35
1.4	DRIVE MODELS AND ENCLOSURE TYPES.....	39
1.5	COMPONENT NAMES.....	42

1.1 Section Safety

CAUTION

Do not carry the drive by the front cover or the terminal cover.

Failure to comply may cause the main body of the drive to fall, resulting in minor or moderate injury.

NOTICE

Observe proper electrostatic discharge procedures (ESD) when handling the drive and circuit boards.

Failure to comply may result in ESD damage to the drive circuitry.

A motor connected to a PWM drive may operate at a higher temperature than a utility-fed motor and the operating speed range may reduce motor cooling capacity.

Ensure that the motor is suitable for drive duty and/or the motor service factor is adequate to accommodate the additional heating with the intended operating conditions.

1.2 General Description

◆ A1000 Model Selection

Refer to [Table 1.1](#) for drive selection depending on the motor power and Normal Duty (ND) or Heavy Duty (HD) rating.

Note: The models and capacities in shown here are based on standard settings and operation conditions. Higher carrier frequencies and higher ambient temperatures require derating.

Table 1.1 A1000 Models

Motor Power HP	Three-Phase 200 V Class				Three-Phase 400 V Class				Three-Phase 600 V Class			
	Heavy Duty Rating		Normal Duty Rating		Heavy Duty Rating		Normal Duty Rating		Heavy Duty Rating		Normal Duty Rating	
	Drive Model	Rated Output Current (A)	Drive Model	Rated Output Current (A) <3>	Drive Model	Rated Output Current (A)	Drive Model	Rated Output Current (A) <3>	Drive Model	Rated Output Current (A)	Drive Model	Rated Output Current (A) <3>
0.75	2A0004	3.2 <1>	2A0004	3.5	4A0002	1.8 <1>	4A0002	2.1	–	–	–	–
1	2A0006	5 <1>	2A0006	6	–	–	–	–	5A0003	1.7	–	–
2	2A0008	6.9 <1>	2A0008	8	4A0004	3.4 <1>	4A0004	4.1	5A0004	3.5	5A0003	2.7
	2A0010	8 <1>	–	–	–	–	–	–	–	–	–	–
3	–	–	–	–	4A0005	4.8 <1>	–	–	–	–	–	–
	2A0012	11 <1>	2A0010	9.6	4A0007	5.5 <1>	4A0005	5.4	5A0006	4.1	5A0004	3.9
	2A0018	14 <1>	2A0012	12	–	–	4A0007	6.9	–	–	–	–
5	–	–	–	–	4A0009	7.2 <1>	–	–	–	–	–	–
	2A0021	17.5 <1>	2A0018	17.5	4A0011	9.2 <1>	4A0009	8.8	5A0009	6.3	5A0006	6.1
7.5	2A0030	25 <1>	2A0021	21	4A0018	14.8 <1>	4A0011	11.1	5A0011	9.8	5A0009	9
10	2A0040	33 <1>	2A0030	30	4A0023	18 <1>	4A0018	17.5	5A0017	12.5	5A0011	11
15	2A0056	47 <1>	2A0040	40	4A0031	24 <1>	4A0023	23	5A0022	17	5A0017	17
20	2A0069	60 <1>	2A0056	56	4A0038	31 <1>	4A0031	31	5A0027	22	5A0022	22
25	2A0081	75 <1>	2A0069	69	–	–	4A0038	38	5A0032	27	5A0027	27
25-30	–	–	–	–	4A0044	39 <1>	–	–	–	–	–	–
	–	–	–	–	4A0058	45 <1>	–	–	5A0041	32	–	–
30	2A0110	85 <1>	2A0081	81	–	–	4A0044	44	–	–	5A0032	32
40	2A0138	115 <1>	2A0110	110	4A0072	60 <1>	4A0058	58	5A0052	41	5A0041	41
50	2A0169	145 <2>	2A0138	138	–	–	4A0072	72	–	–	5A0052	52
50-60	–	–	–	–	4A0088	75 <1>	–	–	5A0062	52	–	–
	–	–	–	–	4A0103	91 <1>	–	–	5A0077	62	–	–
60	2A0211	180 <2>	2A0169	169	–	–	4A0088	88	–	–	5A0062	62
75	2A0250	215 <2>	2A0211	211	4A0139	112 <2>	4A0103	103	5A0099	77	5A0077	77
100	2A0312	283 <2>	2A0250	250	4A0165	150 <2>	4A0139	139	5A0125	99	5A0099	99
125	2A0360	346 <2>	2A0312	312	–	–	4A0165	165	5A0145	130	5A0125	125
125-150	–	–	–	–	4A0208	180 <2>	–	–	–	–	–	–
150	2A0415	415 <2>	2A0360	360	4A0250	216 <2>	4A0208	208	5A0192	172	5A0145	145
175	–	–	2A0415	415	–	–	–	–	–	–	–	–
200	–	–	–	–	4A0296	260 <2>	4A0250	250	5A0242	200	5A0192	192
250	–	–	–	–	4A0362	304 <2>	4A0296	296	–	–	5A0242	242
300	–	–	–	–	4A0414	370 <2>	4A0362	362	–	–	–	–
350	–	–	–	–	4A0515	450 <3>	4A0414	414	–	–	–	–
400-450	–	–	–	–	–	–	4A0515	515	–	–	–	–

1.2 General Description

Motor Power HP	Three-Phase 200 V Class				Three-Phase 400 V Class				Three-Phase 600 V Class			
	Heavy Duty Rating		Normal Duty Rating		Heavy Duty Rating		Normal Duty Rating		Heavy Duty Rating		Normal Duty Rating	
	Drive Model	Rated Output Current (A)	Drive Model	Rated Output Current (A) <3>	Drive Model	Rated Output Current (A)	Drive Model	Rated Output Current (A) <3>	Drive Model	Rated Output Current (A)	Drive Model	Rated Output Current (A) <3>
400-450-500	-	-	-	-	4A0675	605 <2>	-	-	-	-	-	-
500-550	-	-	-	-	-	-	4A0675	675	-	-	-	-
650	-	-	-	-	4A0930	810 <3>	-	-	-	-	-	-
750	-	-	-	-	-	-	4A0930	930	-	-	-	-
900	-	-	-	-	4A1200	1090 <3>	-	-	-	-	-	-
1000	-	-	-	-	-	-	4A1200	1200	-	-	-	-

<1> These values assume the carrier frequency is not set higher than 8 kHz.

<2> These values assume the carrier frequency is not set higher than 5 kHz.

<3> These values assume the carrier frequency is set to 2 kHz.

Note: Current derating is required when setting the carrier frequency higher. *Refer to Carrier Frequency Derating on page 482* for details.

◆ Control Mode Selection

Table 1.2 gives an overview of the A1000 control modes and their various features.

Table 1.2 Control Modes and their Features

Motor Type	Induction Motors				Permanent Magnet Motors <99>			Comments	
Control Mode	V/f	V/f w/PG	OLV	CLV	OLV/PM	AOLV/PM	CLV/PM	-	
Parameter Setting	A1-02 = 0	A1-02 = 1	A1-02 = 2	A1-02 = 3	A1-02 = 5	A1-02 = 6	A1-02 = 7	Default Setting is OLV control (A1-02 = 2)	
Basic Description	V/f control	V/f control using motor speed feedback	Open Loop Vector control	Closed Loop Vector control	Open Loop Vector control for PM motors	Open Loop Vector control for IPM motors	Closed Loop Vector control for PM motors	-	
Type of Applications	Motor Type	IM	IM	IM	IM	PM	IPM	PM	-
	Multi Motor	YES	-	-	-	-	-	-	-
	Motor data unknown	YES	-	-	-	-	-	-	-
	High Speed Accuracy	-	YES	YES	YES	YES	YES	YES	-
	High Speed Response	-	-	YES	YES	-	YES	YES	-
	Zero Speed Control	-	-	-	YES	-	YES	YES	-
	Torque Control Operation	-	-	-	YES	-	YES	YES	-
Torque Limit Operation	-	-	YES	YES	-	-	YES	-	
PG Option Card	-	PG-B3 or PG-X3	-	PG-B3 or PG-X3	-	-	PG-X3	-	

Motor Type		Induction Motors				Permanent Magnet Motors <99>			Comments
Control Characteristics	Speed Control Range	1:40	1:40	1:200	1:1500	1:20	1:100	1:1500	May fluctuate with characteristics and motor temperature.
	Speed Accuracy	±2 to 3%	±0.03%	±0.2%	±0.02%	±0.2%	±0.2%	±0.02%	Speed deviation when operating at constant speed may fluctuate with characteristics and motor temperature.
	Speed Response	3 Hz (approx.)	3 Hz (approx.)	10 Hz	50 Hz	10 Hz	10 Hz	50 Hz	Max. frequency of a speed reference signal that the drive can follow may fluctuate with characteristics and motor temperature.
	Starting Torque	150% at 3 Hz	150% at 3 Hz	200% at 0.3 Hz	200% at 0 r/min	100% at 5% speed	200% at 0 r/min	200% at 0 r/min	Starting torque may fluctuate with characteristics and motor temperature. Performance may differ by capacity.
Application-Specific	Auto-Tuning	<ul style="list-style-type: none"> Energy Saving Tuning Line to line resistance 	<ul style="list-style-type: none"> Energy Saving Tuning Line to line resistance 	<ul style="list-style-type: none"> Rotational Stationary Line to line resistance 	<ul style="list-style-type: none"> Rotational Stationary Line to line resistance ASR Inertia 	<ul style="list-style-type: none"> Stationary Stator resistance 	<ul style="list-style-type: none"> Stationary Stator resistance 	<ul style="list-style-type: none"> Stationary Stator resistance ASR Inertia Encoder offset Back EMF Constant 	Automatically adjusts parameter settings that concern electrical characteristics of the motor.
	Torque Limit	–	–	YES	YES	–	YES	YES	Sets the maximum torque for the motor to protect the load and connected machinery.
	Torque Control	–	–	–	YES	–	–	YES	Allows direct control of motor torque for tension control and other such applications.

1.2 General Description

Motor Type		Induction Motors				Permanent Magnet Motors <99>			Comments
Application-Specific	Droop Function	-	-	-	YES	-	-	YES	-
	Zero Servo Control	-	-	-	YES	-	-	YES	Locks the rotor position.
	Speed Search	YES	YES	YES	-	YES	YES	YES	Bi-directional speed detection of a coasting motor to restart it without stopping.
	Energy-Saving Control	YES	YES	YES	YES	-	YES (IPM motors only)	YES (IPM motors only)	Saves energy by always operating the motor at its maximum efficiency.
	High Slip Braking	YES	YES	-	-	-	-	-	Increases motor loss to allow for faster deceleration than normal without a braking resistor. Effectiveness may vary based on motor characteristics.
	Feed Forward Control	-	-	-	YES	-	-	YES	Improves speed accuracy when the load changes by compensating effects of the system inertia.
	Kinetic Energy Buffering	YES	YES	YES	YES	YES	YES	YES	Decelerates the drive to allow it to ride through a momentary power loss and continue operation.
	Over-excitation Deceleration	YES	YES	YES	YES	-	-	-	Provides fast deceleration without using a braking resistor.
	Inertia Tuning, ASR Tuning	-	-	-	YES	-	-	YES	Provides automatic Speed Control and Feed Forward function tuning.
	Overvoltage Suppression	YES	YES	YES	YES	YES	YES	YES	Prevents overvoltage by increasing speed during regeneration.
High Frequency Injection	-	-	-	-	-	YES (IPM motor)	-	Greatly increases the speed control range of an IPM motor.	

<99> PM motor control modes are not available on 600 V class drives, models 5A□□□□.

1.3 Model Number and Nameplate Check

Please perform the following tasks after receiving the drive:

- Inspect the drive for damage.
- If the drive appears damaged upon receipt, contact the shipper immediately.
- Verify receipt of the correct model by checking the information on the nameplate.
- If you have received the wrong model or the drive does not function properly, contact your supplier.

◆ Nameplate

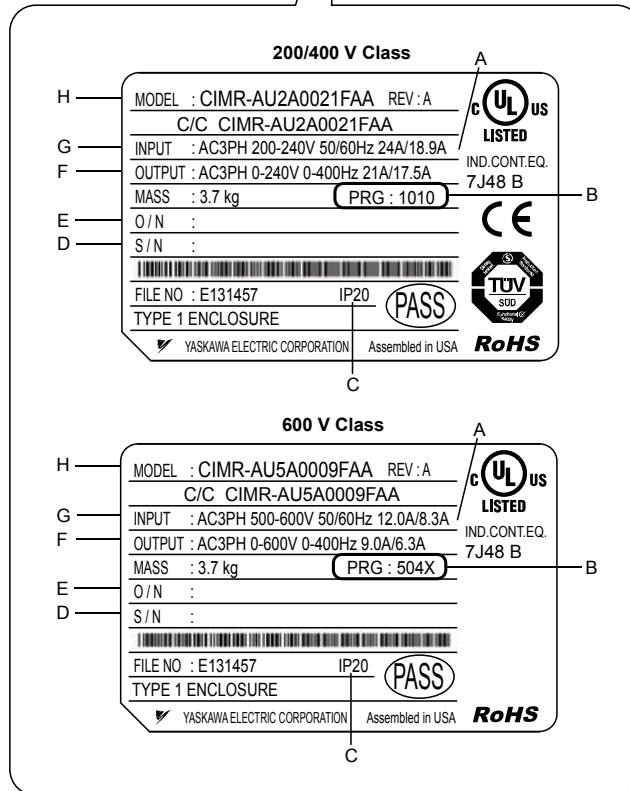
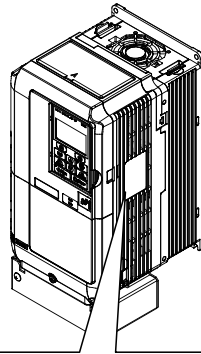

- | | |
|---|----------------------------------|
| A – Normal Duty Amps / Heavy Duty Amps | E – Lot number |
| B – Software version <1> | F – Output specifications |
| C – Enclosure type | G – Input specifications |
| D – Serial number | H – AC drive model |

Figure 1.1 Nameplate Information Example

<1> Drive models 4A0930 and 4A1200 use software version 301□. The availability of certain functions on these models differs from other 200 V and 400 V class models, which use software version 101□. Refer to Parameter List on page 489 for details.

1.3 Model Number and Nameplate Check

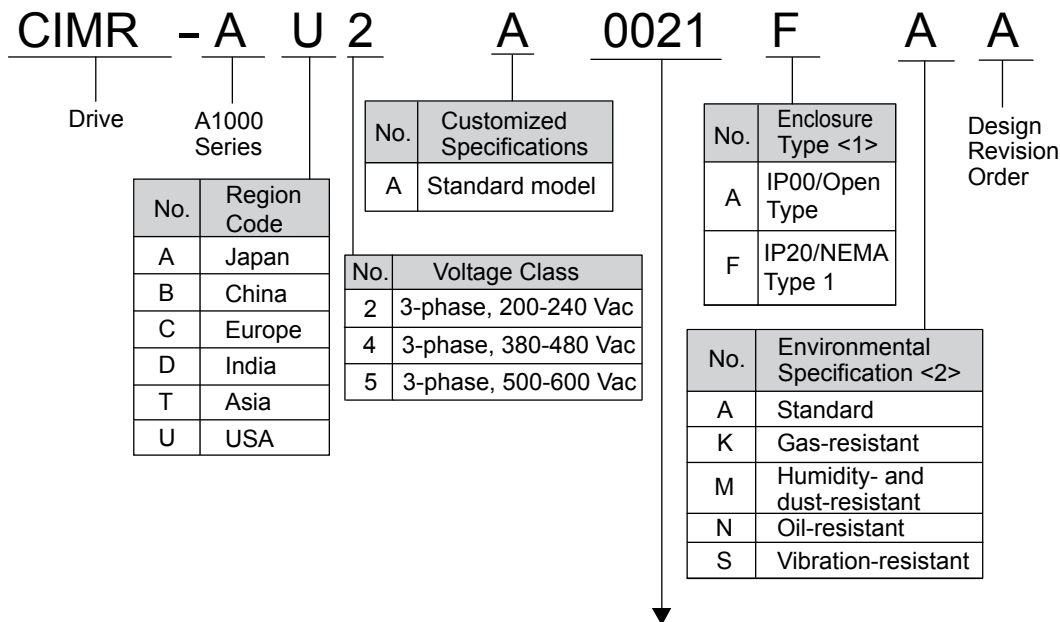

Refer to the tables below

<1> [Refer to Drive Models and Enclosure Types on page 39](#) for differences regarding enclosure protection types and component descriptions.

<2> Drives with these specifications do not guarantee complete protection for the environmental conditions indicated.

■ Three-Phase 200 V

Table 1.3 Model Number and Specifications (200 V)

Normal Duty (ND) C6-01 = 1		
Drive Model	Max. Motor Capacity kW (HP)	Rated Output Current A
2A0004	0.75 (0.75)	3.5
2A0006	1.1 (1)	6.0
2A0008	1.5 (2)	8.0
2A0010	2.2 (3)	9.6
2A0012	3.0 (3)	12
2A0018	3.7 (5)	17.5
2A0021	5.5 (7.5)	21
2A0030	7.5 (10)	30
2A0040	11 (15)	40
2A0056	15 (20)	56
2A0069	18.5 (25)	69
2A0081	22 (30)	81
2A0110	30 (40)	110
2A0138	37 (50)	138
2A0169	45 (60)	169
2A0211	55 (75)	211
2A0250	75 (100)	250
2A0312	90 (125)	312
2A0360	110 (150)	360
2A0415	110 (175)	415

Heavy Duty (HD) C6-01 = 0		
Drive Model	Max. Motor Capacity kW (HP)	Rated Output Current A
2A0004	0.4 (0.75)	3.2
2A0006	0.75 (1)	5
2A0008	1.1 (2)	6.9
2A0010	1.5 (2)	8
2A0012	2.2 (3)	11
2A0018	3.0 (3)	14.0
2A0021	3.7 (5)	17.5
2A0030	5.5 (7.5)	25
2A0040	7.5 (10)	33
2A0056	11 (15)	47
2A0069	15 (20)	60
2A0081	18.5 (25)	75
2A0110	22 (30)	85
2A0138	30 (40)	115
2A0169	37 (50)	145
2A0211	45 (60)	180
2A0250	55 (75)	215
2A0312	75 (100)	283
2A0360	90 (125)	346
2A0415	110 (150)	415

■ Three-Phase 400 V

Table 1.4 Model Number and Specifications (400 V)

Normal Duty (ND) C6-01 = 1		
Drive Model	Max. Motor Capacity kW (HP)	Rated Output Current A
4A0002	0.75 (0.75)	2.1
4A0004	1.5 (2)	4.1
4A0005	2.2 (3)	5.4
4A0007	3.0 (3)	6.9
4A0009	3.7 (5)	8.8
4A0011	5.5 (7.5)	11.1
4A0018	7.5 (10)	17.5
4A0023	11 (15)	23
4A0031	15 (20)	31
4A0038	18.5 (25)	38
4A0044	22 (30)	44
4A0058	30 (40)	58
4A0072	37 (50)	72
4A0088	45 (60)	88
4A0103	55 (75)	103
4A0139	75 (100)	139
4A0165	90 (125)	165
4A0208	110 (150)	208
4A0250	132 (200)	250
4A0296	160 (250)	296
4A0362	185 (300)	362
4A0414	220 (350)	414
4A0515	250 (400-450)	515
4A0675	355 (500-550)	675
4A0930	500 (750)	930
4A1200	630 (1000)	1200

Heavy Duty (HD) C6-01 = 0		
Drive Model	Max. Motor Capacity kW (HP)	Rated Output Current A
4A0002	0.4 (0.75)	1.8
4A0004	0.75 (2)	3.4
4A0005	1.5 (3)	4.8
4A0007	2.2 (3)	5.5
4A0009	3.0 (5)	7.2
4A0011	3.7 (5)	9.2
4A0018	5.5 (7.5)	14.8
4A0023	7.5 (10)	18
4A0031	11 (15)	24
4A0038	15 (20)	31
4A0044	18.5 (25-30)	39
4A0058	22 (25-30)	45
4A0072	30 (40)	60
4A0088	37 (50-60)	75
4A0103	45 (50-60)	91
4A0139	55 (75)	112
4A0165	75 (100)	150
4A0208	90 (125-150)	180
4A0250	110 (150)	216
4A0296	132 (200)	260
4A0362	160 (250)	304
4A0414	185 (300)	370
4A0515	220 (350)	450
4A0675	315 (400-450-500)	605
4A0930	450 (650)	810
4A1200	560 (900)	1090

1.3 Model Number and Nameplate Check

■ Three-Phase 600 V

Table 1.5 Model Number and Specifications (600 V)

Normal Duty (ND) C6-01 = 1		
Drive Model	Max. Motor Capacity kW (HP)	Rated Output Current A
5A0003	1.5 (2)	2.7
5A0004	2.2 (3)	3.9
5A0006	3.7 (5)	6.1
5A0009	5.5 (7.5)	9
5A0011	7.5 (10)	11
5A0017	11 (15)	17
5A0022	15 (20)	22
5A0027	18.5 (25)	27
5A0032	22 (30)	32
5A0041	30 (40)	41
5A0052	37 (50)	52
5A0062	45 (60)	62
5A0077	55 (75)	77
5A0099	75 (100)	99
5A0125	90 (125)	125
5A0145	110 (150)	145
5A0192	160 (200)	192
5A0242	185 (250)	242

Heavy Duty (HD) C6-01 = 0		
Drive Model	Max. Motor Capacity kW (HP)	Rated Output Current A
5A0003	0.75 (1)	1.7
5A0004	1.5 (2)	3.5
5A0006	2.2 (3)	4.1
5A0009	3.7 (5)	6.3
5A0011	5.5 (7.5)	9.8
5A0017	7.5 (10)	12.5
5A0022	11 (15)	17
5A0027	15 (20)	22
5A0032	18.5 (25)	27
5A0041	22 (25-30)	32
5A0052	30 (40)	41
5A0062	37 (50-60)	52
5A0077	45 (50-60)	62
5A0099	55 (75)	77
5A0125	75 (100)	99
5A0145	90 (125)	130
5A0192	110 (150)	172
5A0242	160 (200)	200

1.4 Drive Models and Enclosure Types

Two types of enclosures are offered for A1000 drives:

- IP20/NEMA Type 1 enclosure models mount to an indoor wall or in an enclosure panel.
- IP00/Open Type enclosure models are designed for installation in an enclosure panel that serves to protect personnel from injury caused by accidentally touching live parts.

Table 1.6 describes drive enclosures and models.

Table 1.6 Drive Models and Enclosure Types

Voltage Class	Enclosure Type	
	IP20/NEMA Type 1 Enclosure </> Drive Model	IP00/Open Type Enclosure Drive Model
Three-Phase 200 V Class	2A0004F	</>
	2A0006F	</>
	2A0008F	</>
	2A0010F	</>
	2A0012F	</>
	2A0018F	</>
	2A0021F	</>
	2A0030F	</>
	2A0040F	</>
	2A0056F	</>
	2A0069F	</>
	2A0081F	</>
	2A0110F	</>
	2A0138F	</>
	2A0169F	</>
	2A0211F	</>
	</>	2A0250A
	</>	2A0312A
	</>	2A0360A
	</>	2A0415A

1.4 Drive Models and Enclosure Types

Voltage Class	Enclosure Type	
	IP20/NEMA Type 1 Enclosure </> Drive Model	IP00/Open Type Enclosure Drive Model
Three-Phase 400 V Class	4A0002F	</>
	4A0004F	</>
	4A0005F	</>
	4A0007F	</>
	4A0009F	</>
	4A0011F	</>
	4A0018F	</>
	4A0023F	</>
	4A0031F	</>
	4A0038F	</>
	4A0044F	</>
	4A0058F	</>
	4A0072F	</>
	4A0088F	</>
	4A0103F	</>
	4A0139F	</>
Three-Phase 400 V Class	4A0165F	</>
	</>	4A0208A
	</>	4A0250A
	</>	4A0296A
	</>	4A0362A
	</>	4A0414A
	</>	4A0515A
	</>	4A0675A
	</>	4A0930A
</>	4A1200A	

Voltage Class	Enclosure Type	
	IP20/NEMA Type 1 Enclosure ^{<1>} Drive Model	IP00/Open Type Enclosure Drive Model
Three-Phase 600 V Class	5A0003F	<1>
	5A0004F	<1>
	5A0006F	<1>
	5A0009F	<1>
	5A0011F	<1>
	5A0017F	<1>
	5A0022F	<1>
	5A0027F	<1>
	5A0032F	<1>
	5A0041F	<1>
	5A0052F	<1>
	5A0062F	<1>
	5A0077F	<1>
	5A0099F	<1>
	<2>	5A0125A
	<2>	5A0145A
	<2>	5A0192A
<2>	5A0242A	

- <1> Removing the top protective cover from a IP20/NEMA Type 1 enclosure drive voids NEMA Type 1 protection while retaining IP20 conformity.
- <2> Customers may convert these models to IP20/NEMA Type 1 enclosures using an IP20/NEMA Type 1 Kit. [Refer to IP20/NEMA Type 1 Kit Selection on page 67](#) to select the appropriate kit.
- <3> Contact a Yaskawa representative for IP20/NEMA Type 1 Kit availability for these models.

1.5 Component Names

This section gives an overview of the drive components described in this manual.

- Note:**
1. Refer to *Using the Digital Operator on page 115* for a description of the operator keypad.
 2. The drive may have no cooling fans or up to two cooling fans depending on the model.

◆ IP20/NEMA Type 1 Enclosure

- Three-Phase AC 200 V Models 2A0004F to 2A0081F
- Three-Phase AC 400 V Models 4A0002F to 4A0044F
- Three-Phase AC 600 V Models 5A0003F to 5A0032F

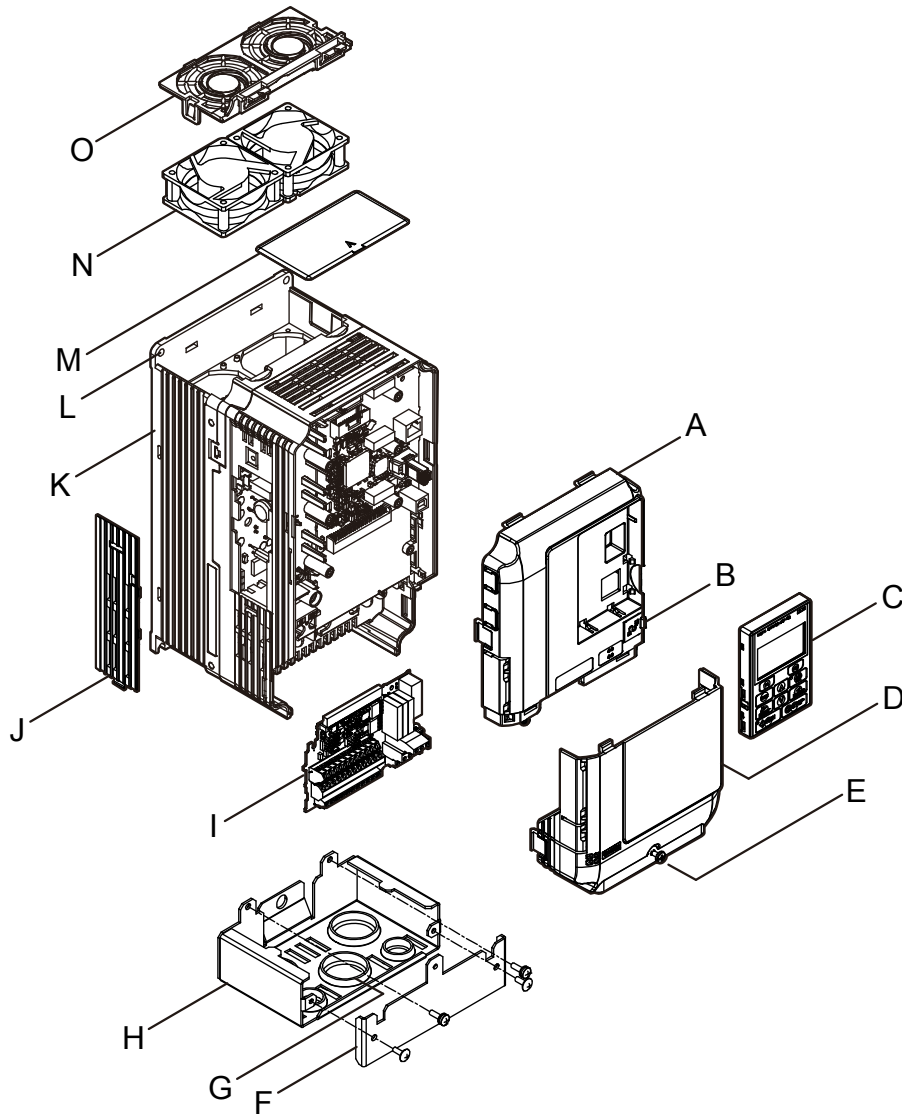

- | | |
|---------------------------------|---|
| A – Front cover | I – Terminal board |
| B – USB port (type-B) | J – Optional 24 V DC power supply connector cover |
| C – Digital operator | K – Heatsink |
| D – Terminal cover | L – Mounting hole |
| E – Terminal cover screw | M – Top protective cover |
| F – Conduit bracket front cover | N – Cooling fan <1> |
| G – Rubber bushing | O – Fan finger guard <1> |
| H – Conduit bracket | |

Figure 1.2 Exploded View of IP20/NEMA Type 1 Components (Model 2A0030F)

<1> Drive models 2A0018, 2A0021, 4A0007 to 4A0011, 5A0006F, and 5A0009F have a single cooling fan. Drive models 2A0004 to 2A0012, 4A0002 to 4A0005, 5A0003F, and 5A0004F do not have a cooling fan or a fan finger guard.

- Three-Phase AC 200 V Models 2A0110F, 2A0138F
- Three-Phase AC 400 V Models 4A0058F to 4A0103F
- Three-Phase AC 600 V Models 5A0041F, 5A0052F

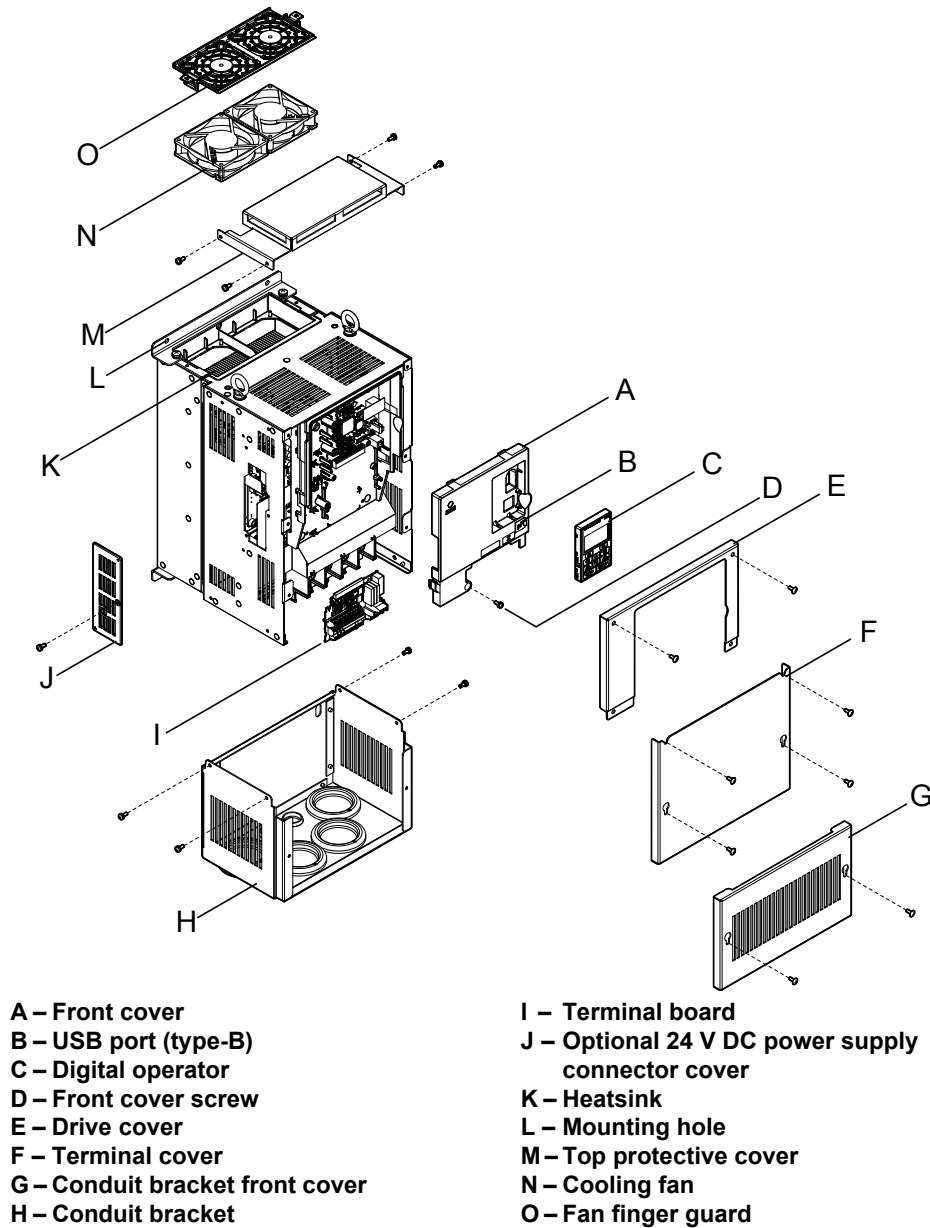
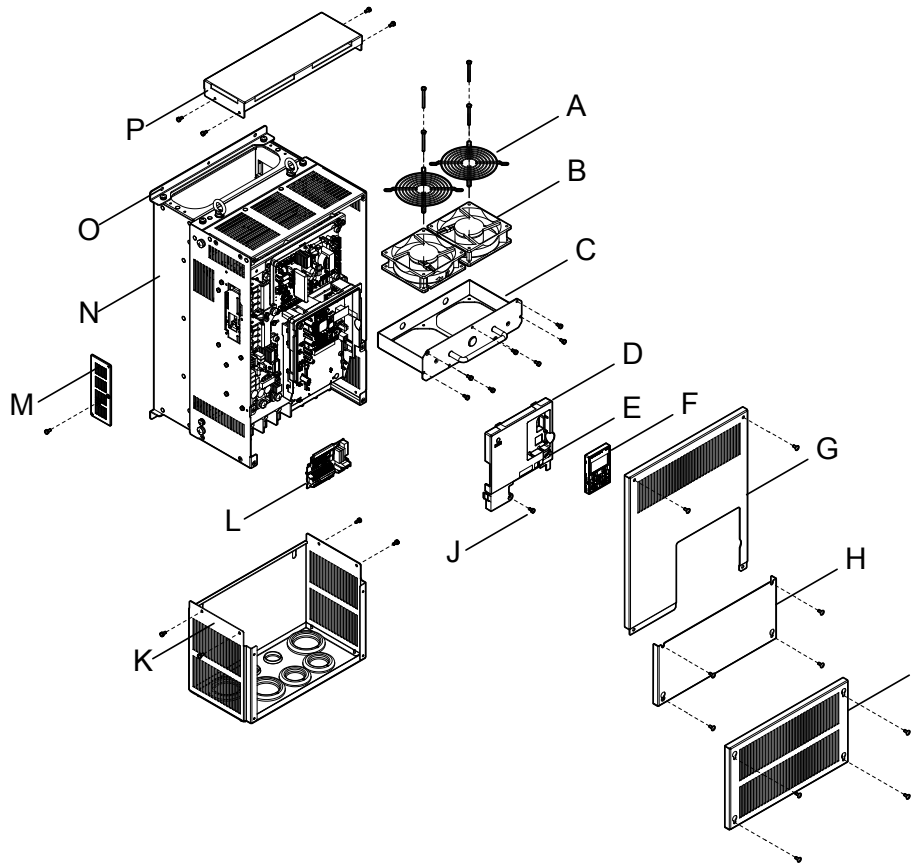

Figure 1.3 Exploded View of IP20 Enclosure Components (Model 2A0110F)

1.5 Component Names

- Three-Phase AC 200 V Models 2A0169F, 2A0211F
- Three-Phase AC 400 V Models 4A0139F to 4A0165F
- Three-Phase AC 600 V Models 5A0062F to 5A0099F



- | | |
|-----------------------|--|
| A – Fan guard | I – Conduit bracket front cover |
| B – Cooling fan | J – Front cover |
| C – Fan bracket | K – Conduit bracket |
| D – Front cover | L – Terminal board |
| E – USB port (type-B) | M – Optional 24 V DC power supply
connector cover |
| F – Digital operator | N – Heatsink |
| G – Drive cover | O – Mounting hole |
| H – Terminal cover | P – Top protective cover |

Figure 1.4 Exploded View of IP20/NEMA Type 1 Enclosure Components (Model 4A0165F)

◆ IP00/Open Type Enclosure

- Three-Phase AC 200 V Models 2A0250A, 2A0312A
- Three-Phase AC 400 V Model 4A0208A
- Three-Phase AC 600 V Models 5A0125A, 5A0145A

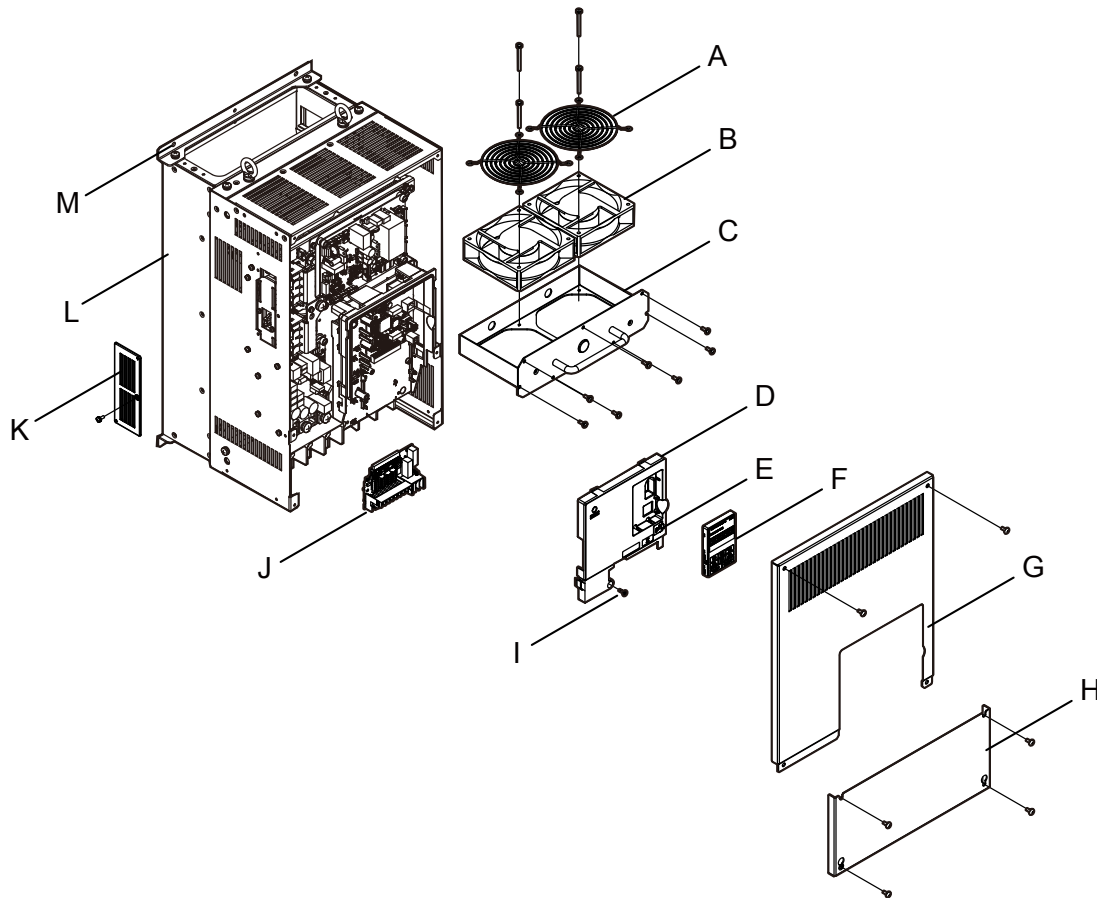

- | | |
|-----------------------|--|
| A – Fan guard | H – Terminal cover |
| B – Cooling fan | I – Front cover screw |
| C – Fan bracket | J – Terminal board |
| D – Front cover | K – Optional 24 V DC power supply
connector cover |
| E – USB port (type-B) | L – Heatsink |
| F – Digital operator | M – Mounting hole |
| G – Drive cover | |

Figure 1.5 Exploded view of IP00/Open Type Enclosure Components (Model 4A0208A)

1.5 Component Names

- Three-Phase AC 200 V Models 2A0360A, 2A0415A
- Three-Phase AC 400 V Models 4A0250A to 4A0362A
- Three-Phase AC 600 V Models 5A0192A, 5A0242A

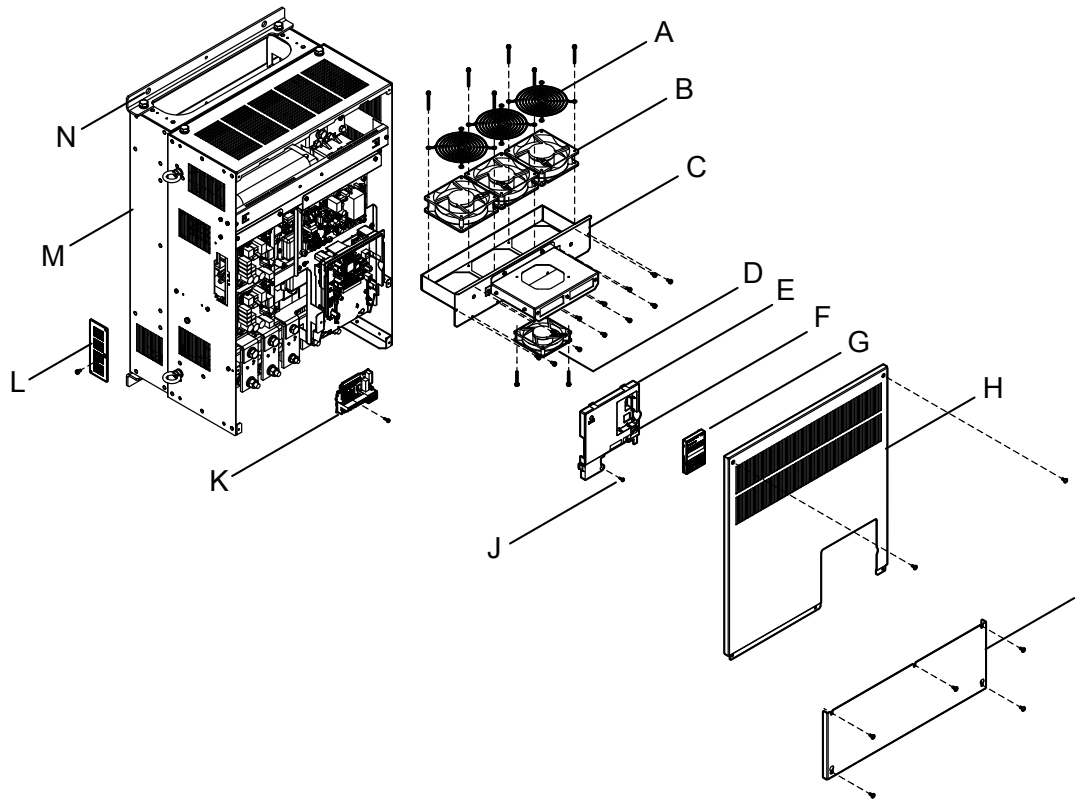

- | | |
|-------------------------|--|
| A – Fan guard | H – Drive cover |
| B – Cooling fan | I – Terminal cover |
| C – Fan bracket | J – Front cover screw |
| D – Circulation fan <1> | K – Terminal board |
| E – Front cover | L – Optional 24 V DC power supply
connector cover |
| F – USB port (type-B) | M – Heatsink |
| G – Digital operator | N – Mounting hole |

Figure 1.6 Exploded view of IP00/Open Type Enclosure Components (Model 4A0362A)

<1> Drive models 2A0360, 2A0415, and 4A0362 have a built-in circulation fan.

■ Three-Phase AC 400 V Model 4A0414A

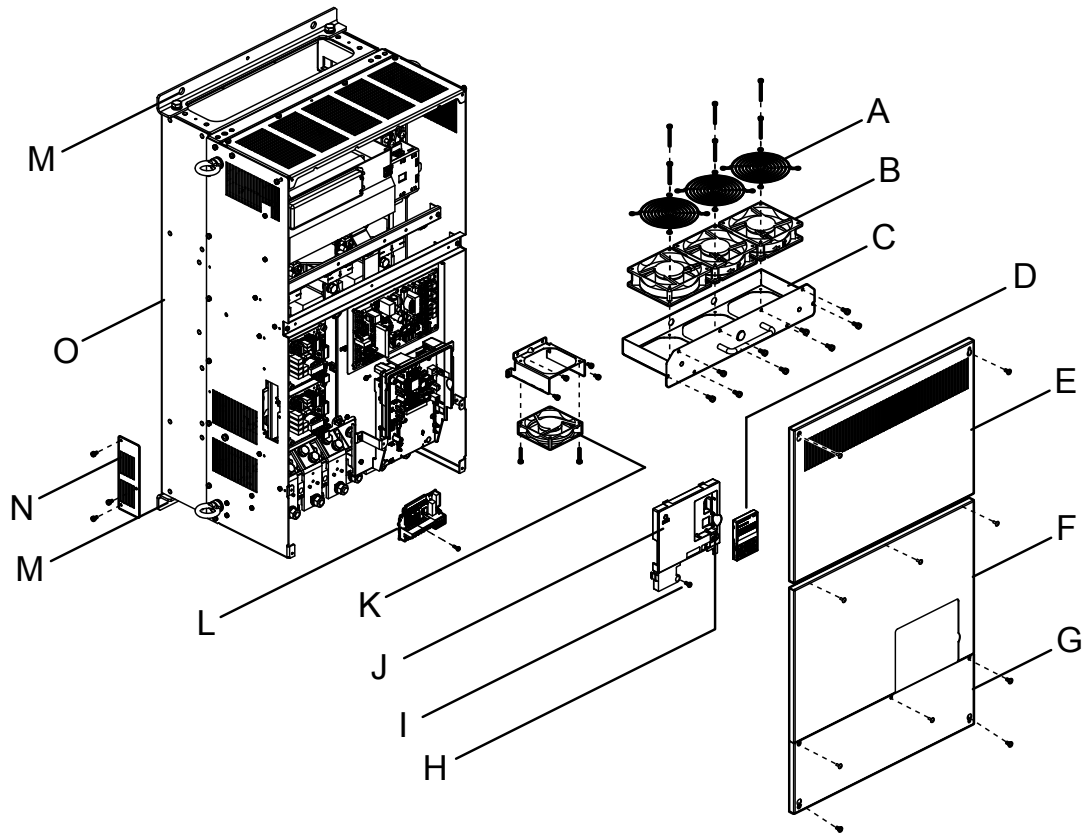

- | | |
|-----------------------|--|
| A – Fan guard | I – Front cover screw |
| B – Cooling fan | J – Front cover |
| C – Fan bracket | K – Circulation fan |
| D – Digital operator | L – Terminal board |
| E – Drive cover 1 | M – Mounting hole |
| F – Drive cover 2 | N – Optional 24 V DC power supply
connector cover |
| G – Terminal cover | O – Heatsink |
| H – USB port (type-B) | |

Figure 1.7 Exploded view of IP00/Open Type Enclosure Components (Model 4A0414A)

■ Three-Phase AC 400 V Models 4A0515A, 4A0675A

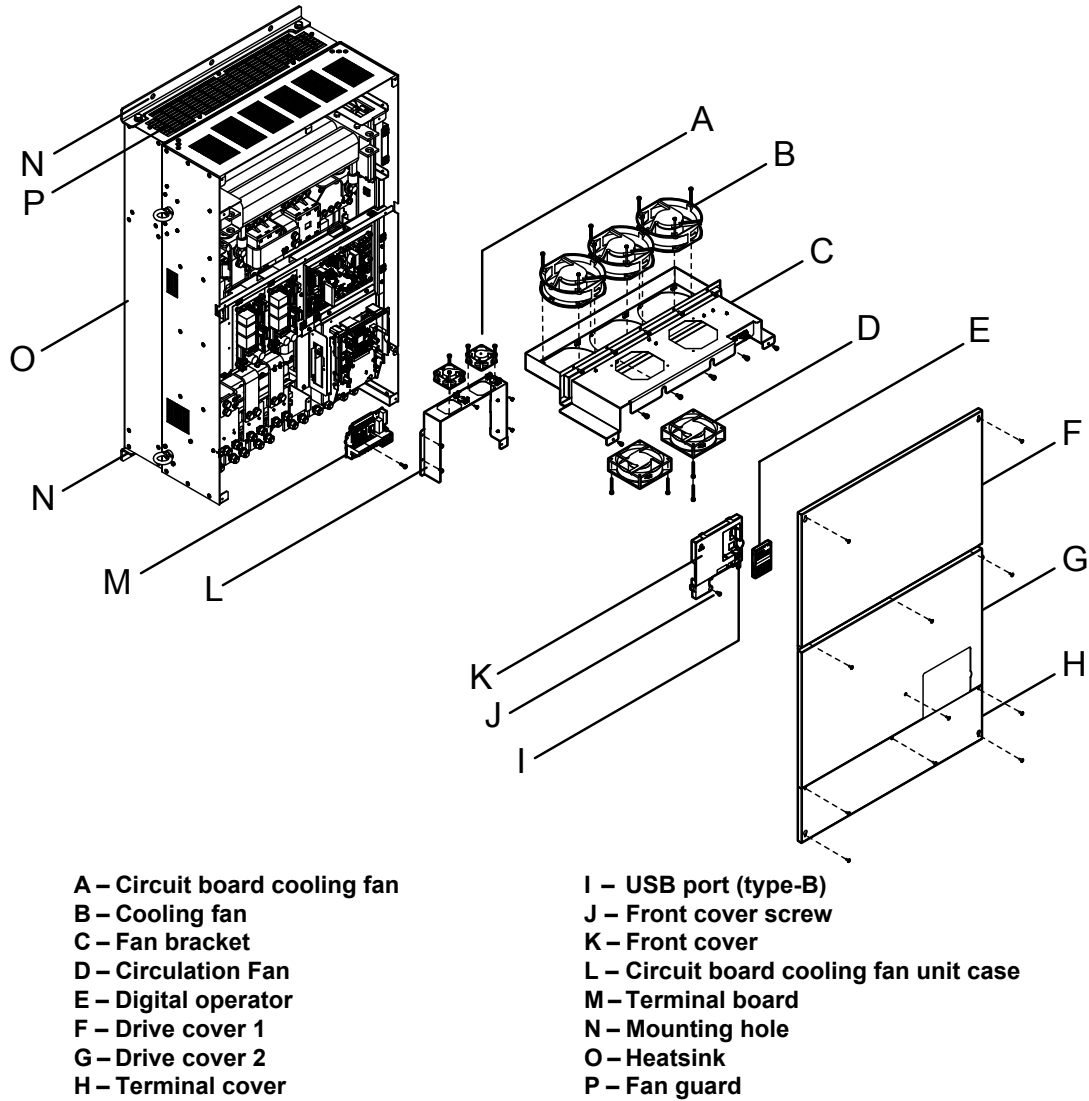
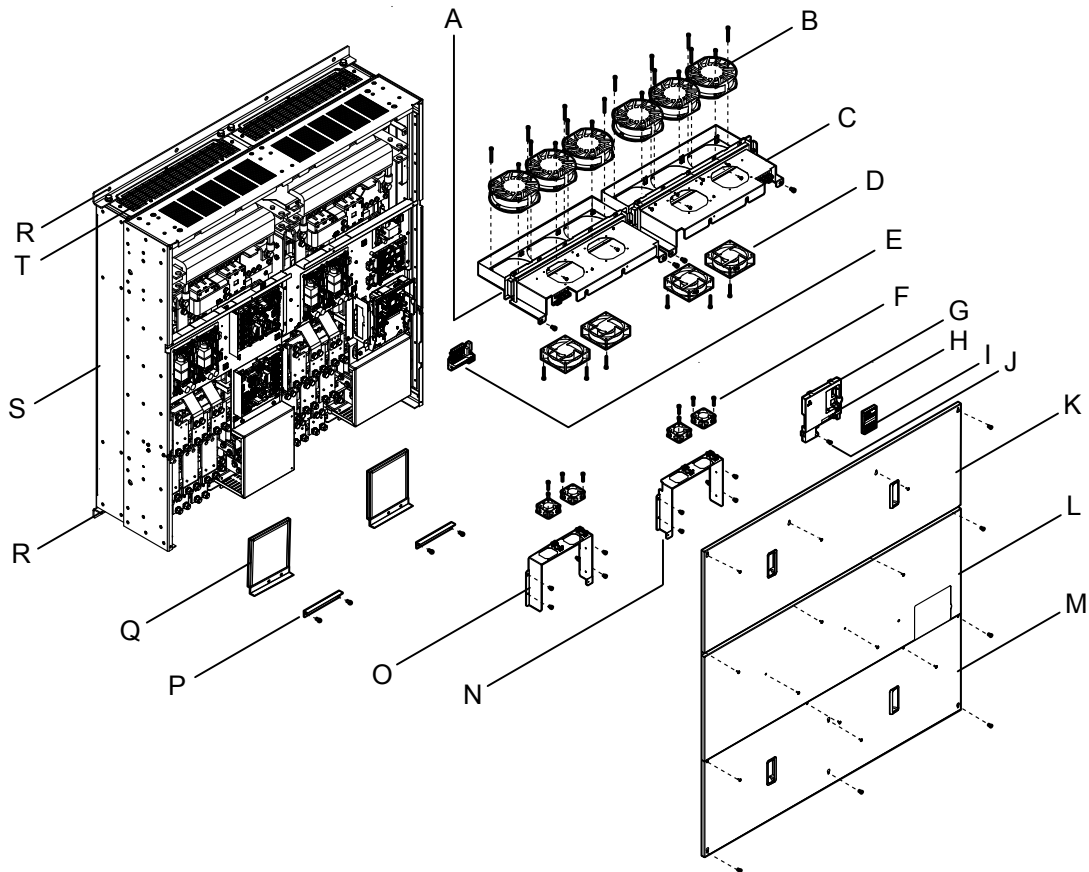

Figure 1.8 Exploded view of IP00/Open Type Enclosure Components (Model 4A0675A)

■ Three-Phase AC 400 V Models 4A0930A, 4A1200A



A – Fan unit case (L)

B – Cooling fan

C – Fan unit case (R)

D – Circulation Fan

E – Terminal board

F – Circuit board cooling fan

G – Front cover

H – USB port (type-B)

I – Digital operator

J – Front cover screw

K – Drive cover 1

L – Drive cover 2

M – Terminal cover

N – Circuit board cooling fan unit case (R)

O – Circuit board cooling fan unit case (L)

P – Blind cover

Q – Filter case

R – Mounting hole

S – Heatsink

T – Fan guard

Figure 1.9 Exploded view of IP00/Open Type Enclosure Components (Model 4A0930A)

◆ Front Views

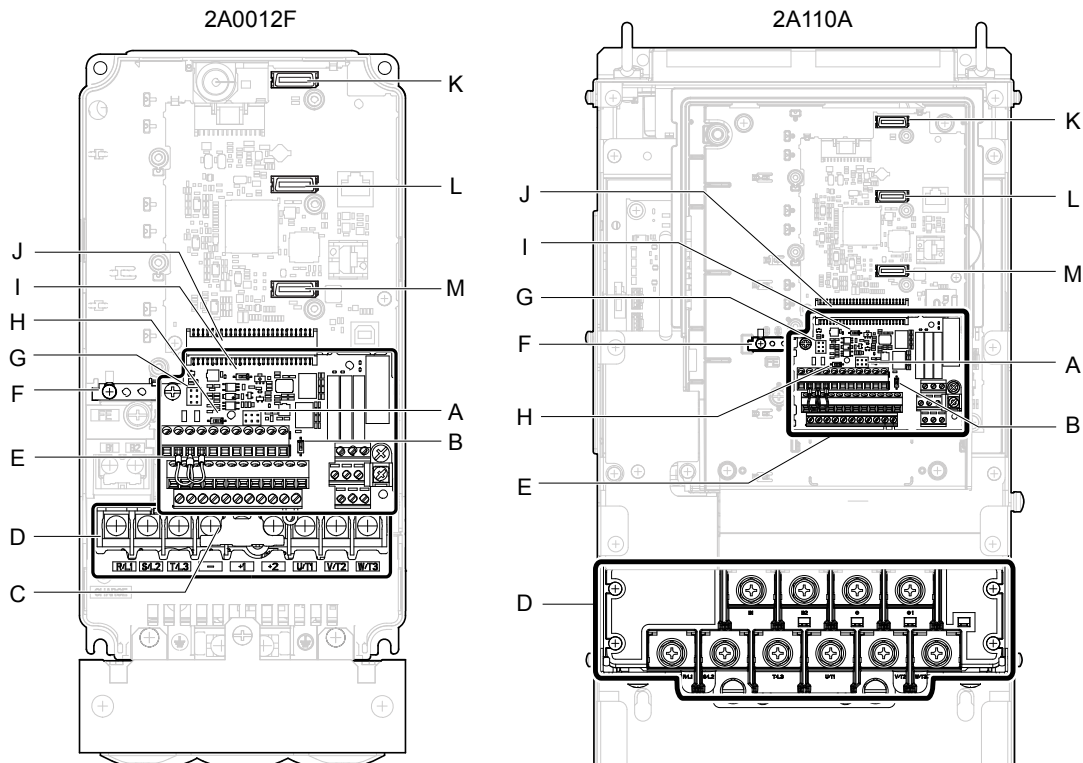

- A – Terminal board connector
- B – DIP switch S1 (*Refer to Terminal A2 Input Signal Selection on page 106*)
- C – DIP switch S2 (*Refer to MEMOBUS/ Modbus Termination on page 107*)
- D – Sink/source jumper S3 (*Refer to Sinking/Sourcing Mode Switch for Digital Inputs on page 104*)
- E – Ground terminal
- F – Terminal board (*Refer to Control Circuit Wiring on page 98*)
- G – Main circuit terminal (*Refer to Wiring the Main Circuit Terminal on page 97*)

- H – Protective cover to prevent miswiring
- I – Option card connector (CN5-C)
- J – Option card connector (CN5-B)
- K – Option card connector (CN5-A)
- L – Jumper S5 (*Refer to Terminal AM/ FM Signal Selection on page 107*)
- M – DIP switch S4 (*Refer to Terminal A3 Analog/PTC Input Selection on page 106*)

Figure 1.10 Front View of Drives

Mechanical Installation

This chapter explains how to properly mount and install the drive.

2.1	SECTION SAFETY.....	52
2.2	MECHANICAL INSTALLATION.....	54

2.1 Section Safety

WARNING

Fire Hazard

Provide sufficient cooling when installing the drive inside an enclosed panel or cabinet.

Failure to comply could result in overheating and fire.

When multiple drives are placed inside the same enclosure panel, install proper cooling to ensure air entering the enclosure does not exceed 40 °C.

Crush Hazard

Only allow qualified personnel to operate a crane or hoist to transport the drive.

Failure to comply may result in serious injury or death from falling equipment.

Use a dedicated lifter when transporting the drive by a lifter.

Failure to comply may result in serious injury or death from falling equipment.

Only use vertical suspension to temporarily lift the drive during installation to an enclosure panel. Do not use vertical suspension to transport the drive.

Failure to comply may result in serious injury or death from falling equipment.

Use screws to securely affix the drive front cover, terminal blocks, and other drive components prior to vertical suspension.

Failure to comply may result in serious injury or death from falling equipment.

Do not subject the drive to vibration or impact greater than 1.96 m/s² (0.2 G) while it is suspended by the cables.

Failure to comply may result in serious injury or death from falling equipment.

Do not attempt to flip the drive over or leave the drive unattended while it is suspended by the wires.

Failure to comply may result in serious injury or death from falling equipment.

CAUTION

Crush Hazard

Do not carry the drive by the front cover or the terminal cover.

Failure to comply may result in minor or moderate injury from the main body of the drive falling.

NOTICE

Equipment Hazard

Prevent foreign matter such as metal shavings or wire clippings from falling into the drive during drive installation and project construction.

Failure to comply could result in damage to the drive. Place a temporary cover over the top during installation. Be sure to remove the temporary cover before start-up, as the cover will reduce ventilation and cause the unit to overheat.

Observe proper electrostatic discharge (ESD) procedures when handling the drive.

Failure to comply could result in ESD damage to the drive circuitry.

Operating the motor in the low-speed range diminishes the cooling effects, increases motor temperature, and may lead to motor damage by overheating.

Reduce the motor torque in the low-speed range whenever using a standard blower cooled motor. If 100% torque is required continuously at low speed, consider using a special drive or vector-control motor. Select a motor that is compatible with the required load torque and operating speed range.

The speed range for continuous operation differs according to the lubrication method and motor manufacturer.

If the motor is to be operated at a speed higher than the rated speed, consult with the manufacturer.

Continuously operating an oil-lubricated motor in the low-speed range may result in burning.

When the input voltage is 440 V or higher or the wiring distance is greater than 100 meters, pay special attention to the motor insulation voltage or use a drive-rated motor with reinforced insulation.

Failure to comply could lead to motor winding failure.

Motor vibration may increase when operating a machine in variable-speed mode, if that machine previously operated at a constant speed.

Install vibration-proof rubber on the motor base or use the frequency jump function to skip a frequency resonating the machine.

The motor may require more acceleration torque with drive operation than with a commercial power supply.

Set a proper V/f pattern by checking the load torque characteristics of the machine to be used with the motor.

The rated input current of submersible motors is higher than the rated input current of standard motors.

Select an appropriate drive according to its rated output current. When the distance between the motor and drive is long, use a cable thick enough to connect the motor to the drive to prevent motor torque reduction.

The current rating differs for a motor with variable pole pitches differs from a standard motor.

Check the maximum current of the motor before selecting the drive capacity. Only switch motor poles when the motor is stopped. Switching between motor during run will trigger overcurrent protection circuitry or result in overvoltage from regeneration, and the motor will simply coast to stop.

When using an explosion-proof motor, it must be subject to an explosion-proof test in conjunction with the drive.

This is also applicable when an existing explosion-proof motor is to be operated with the drive. Since the drive itself is not explosion-proof, always install it in a safe place.

Never lift the drive up while the cover is removed.

This can damage the terminal board and other components.

2.2 Mechanical Installation

This section outlines specifications, procedures, and the environment for proper mechanical installation of the drive.

◆ Installation Environment

Install the drive in an environment matching the specifications in [Table 2.1](#) to help prolong the optimum performance life of the drive.

Table 2.1 Installation Environment

Environment	Conditions
Installation Area	Indoors
Ambient Temperature	-10 °C to +40 °C (IP20/NEMA Type 1 enclosure) -10 °C to +50 °C (IP00/Open Type enclosure) Drive reliability improves in environments without wide temperature fluctuations. When using the drive in an enclosure panel, install a cooling fan or air conditioner in the area to ensure that the air temperature inside the enclosure does not exceed the specified levels. Do not allow ice to develop on the drive.
Humidity	95% RH or less and free of condensation
Storage Temperature	-20 to +60 °C
Surrounding Area	Install the drive in an area free from: <ul style="list-style-type: none"> • oil mist and dust • metal shavings, oil, water, or other foreign materials • radioactive materials • combustible materials (e.g., wood) • harmful gases and liquids • excessive vibration • chlorides • direct sunlight.
Altitude	1000 m or lower, up to 3000 m with derating. Refer to Drive Derating Data on page 476 for details.
Vibration	10 to 20 Hz at 9.8 m/s ² <1> 20 to 55 Hz at 5.9 m/s ² (Models 2A0004 to 2A0211, 4A0002 to 4A0165, and 5A0003 to 5A0099) or 2.0 m/s ² (Models 2A0250 to 2A0415, 4A0208 to 4A1200, and 5A0125 to 5A0242)
Orientation	Install the drive vertically to maintain maximum cooling effects.

<1> Models 4A0930 and 4A1200 are rated at 5.9 m/s²

NOTICE: Avoid placing drive peripheral devices, transformers, or other electronics near the drive as the noise created can lead to erroneous operation. If such devices must be used in close proximity to the drive, take proper steps to shield the drive from noise.

NOTICE: Prevent foreign matter such as metal shavings and wire clippings from falling into the drive during installation. Failure to comply could result in damage to the drive. Place a temporary cover over the top of the drive during installation. Remove the temporary cover before drive start-up, as the cover will reduce ventilation and cause the drive to overheat.

◆ Installation Orientation and Spacing

Install the drive upright as illustrated in [Figure 2.1](#) to maintain proper cooling.

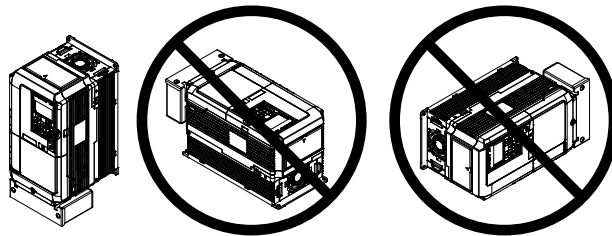

Figure 2.1 Correct Installation Orientation

Single Drive Installation

Figure 2.2 shows the installation distance required to maintain sufficient space for airflow and wiring. Install the heatsink against a closed surface to avoid diverting cooling air around the heatsink.

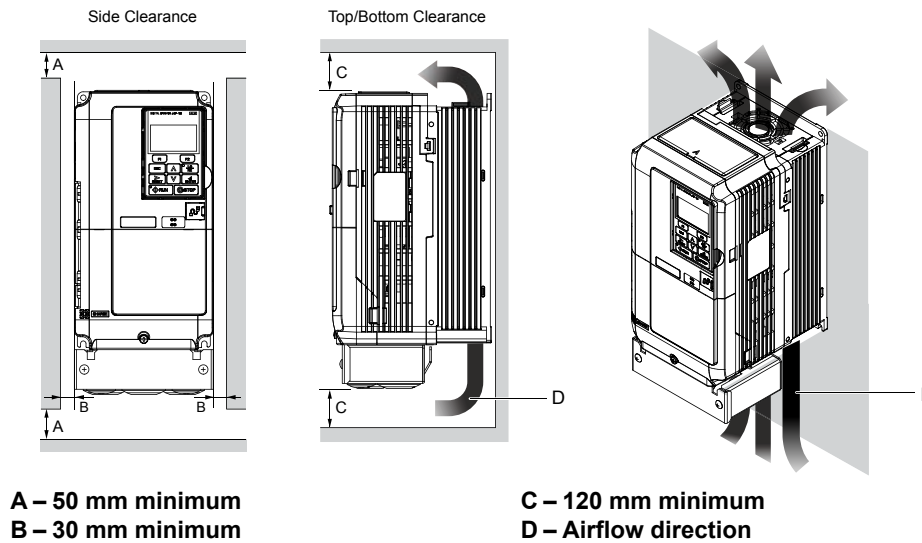

Figure 2.2 Correct Installation Spacing

Note: IP20/NEMA Type 1 enclosure and IP00/Open Type enclosure models require the same amount of space above and below the drive for installation.

Multiple Drive Installation (Side-by-Side Installation)

Models 2A0004 to 2A0081, 4A0002 to 4A0044, and 5A0003 to 5A0032 can take advantage of Side-by-Side installation. When installing multiple drives into the same enclosure panel, mount the drives according to Figure 2.2.

When mounting drives with the minimum clearance of 2 mm according to Figure 2.3, set parameter L8-35 to 1 while considering derating. Refer to L8-35: Installation Method Selection on page 310 for details.

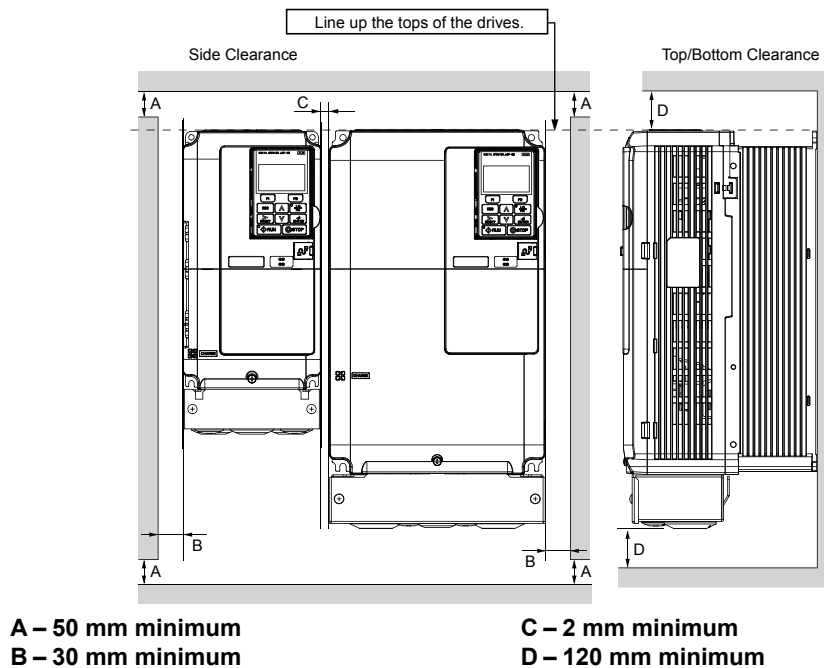

Figure 2.3 Space Between Drives (Side-by-Side Mounting)

Note: Align the tops of the drives when installing drives of different heights in the same enclosure panel. Leave space between the tops and bottoms of stacked drives for easier cooling fan replacement.

Remove the top protective covers of all drives as shown in Figure 2.4 when mounting IP20/NEMA Type 1 enclosure drives side-by-side. Refer to Top Protective Cover on page 86 to remove and reattach the top protective cover.

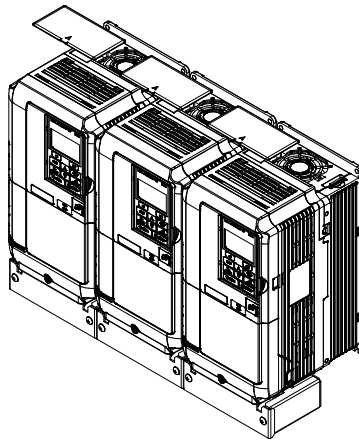

Figure 2.4 IP20/NEMA 1 Side-by-Side Mounting in Enclosure

◆ Precautions and Instructions for Installation of Models 4A0930 and 4A1200

Read the following precautions and instructions before installing models 4A0930 and 4A1200.

WARNING! Crush Hazard. Observe the following instructions and precautions. Failure to comply could result in serious injury or death from falling equipment.

■ Vertical Suspension Procedure

WARNING! Crush Hazard. Use an adequate length of wire to ensure a 50° or wider suspension angle as illustrated in [Figure 2.6](#). The maximum allowable load of the eye bolts cannot be guaranteed when the drive is suspended with the wires at angles less than 50°. Failure to comply may result in serious injury or death from falling equipment.

Use the following procedure to lift the drive with a crane:

1. Remove the four eye bolts from the drive side panels and fix them securely on the top panel.

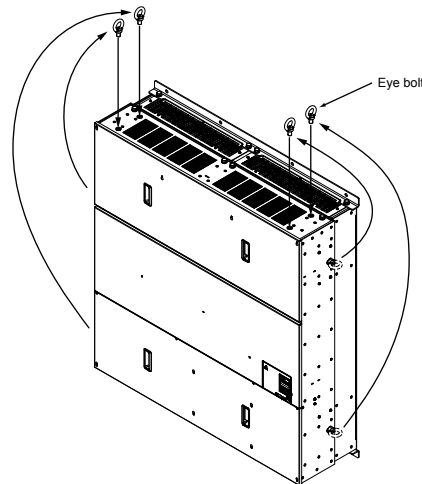
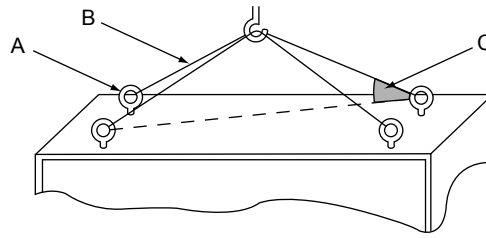

Figure 2.5 Eye Bolt Repositioning

2. Pass wire through the holes of all four eye bolts.



A – Eye bolt
B – Wires

C – Suspending angle: 50° or greater

Figure 2.6 Suspension Wire Angle Example

3. Gradually take up the slack in the wires and hoist the drive after the wires are stretched tight.
4. Lower the drive when ready to install in the enclosure panel. Stop lowering the drive when it is near the floor then begin lowering the drive again very slowly until the drive is placed correctly.

◆ Digital Operator Remote Usage

■ Remote Operation

The digital operator mounted on the drive can be removed and connected to the drive using an extension cable up to 3 m long to facilitate operation when the drive is installed in a location where it can not be easily accessed.

The digital operator can also be permanently mounted remote locations such as panel doors using an extension cable and an installation support set (depending on the installation type).

Note: Refer to *Drive Options and Peripheral Devices* on page 437 for information on extension cables and installation support sets.

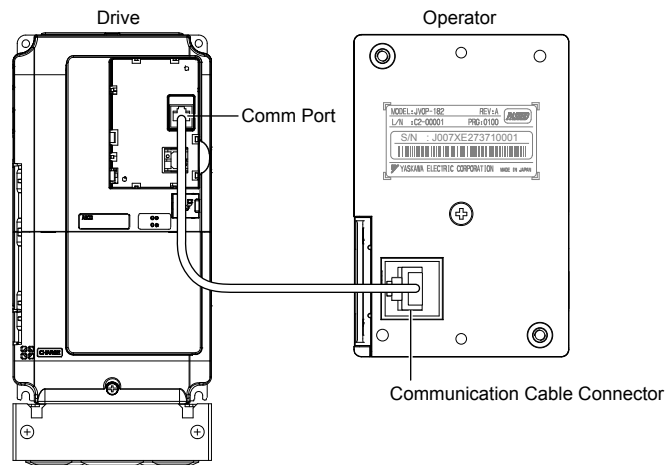

Figure 2.7 Communication Cable Connection

2.2 Mechanical Installation

Digital Operator Remote Installation

Digital Operator Dimensions

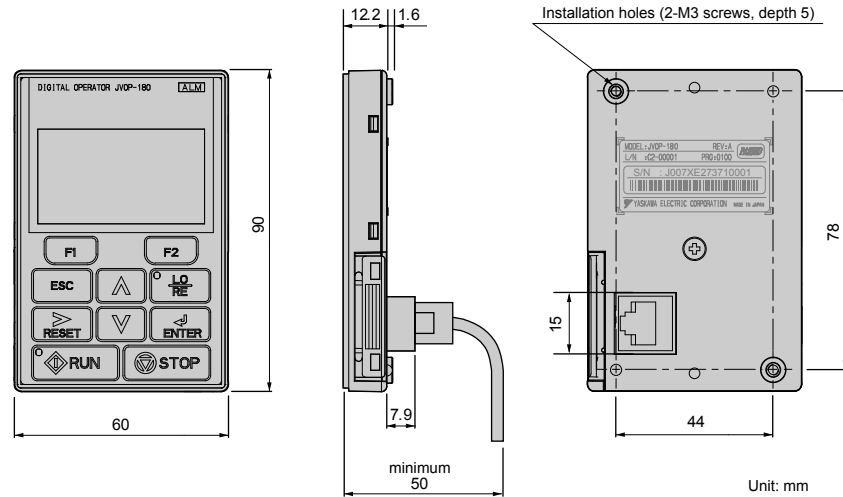

Figure 2.8 Digital Operator Dimensions

NEMA Keypad Kits

Yaskawa offers keypad kits that provide the functionality of the digital operator on enclosures designed for NEMA Type 1, 3R, 4, 4X, 12, or IPX6 environments. These kits are for use with digital operator models JVOP-180 and JVOP-182.

Table 2.2 Installation Environment

Keypad Kit Model	Description
UUX000526	Blank label on the front.
UUX000527	Yaskawa brand label on the front.

Installation Types and Required Materials

The digital operator mounts to an enclosure two different ways:

- **External/face-mount** installs the operator outside the enclosure panel
- **Internal/flush-mount** installs the operator inside the enclosure panel

Table 2.3 Digital Operator Installation Methods and Required Tools

Installation Method	Description	Installation Support Sets	Model	Required Tools
External/ Face-Mount	Simplified installation with the digital operator is mounted on the outside of the panel with two screws.	—	—	Phillips screwdriver (#1)
Internal/ Flush-Mount	Encloses the digital operator in the panel. The front of the digital operator is flush with the outside of the panel.	Installation Support Set A (for mounting with screws through holes in the panel)	EZZ020642A	Phillips screwdriver (#1, #2)
		Installation Support Set B (for use with threaded studs that are fixed to the panel)	EZZ020642B	Phillips screwdriver (#1) Wrench (7 mm)

NOTICE: Prevent foreign matter such as metal shavings or wire clippings from falling into the drive during installation and project construction. Failure to comply could result in damage to the drive. Place a temporary cover over the top of the drive during installation. Remove the temporary cover before drive start-up, as the cover will reduce ventilation and cause the drive to overheat.

External/Face-Mount

1. Cut an opening in the enclosure panel for the digital operator as shown in [Figure 2.10](#).
2. Position the digital operator so the display faces outwards, and mount it to the enclosure panel as shown in [Figure 2.9](#).

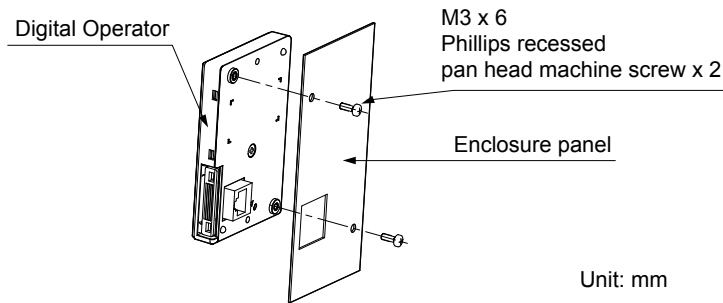

Figure 2.9 External/Face-Mount Installation

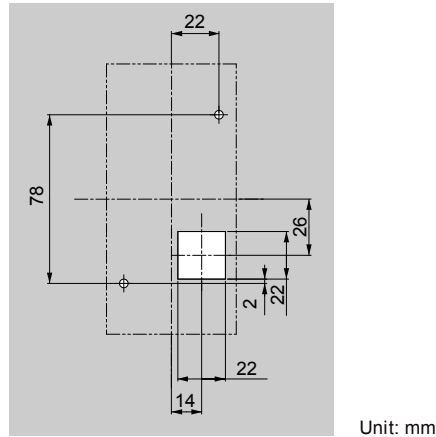

Figure 2.10 Panel Cut-Out Dimensions (External/Face-Mount Installation)

Internal/Flush-Mount

An internal flush-mount requires an installation support set that must be purchased separately. Contact a Yaskawa representative to order an installation support set and mounting hardware. *Figure 2.11* illustrates how to attach the Installation Support Set A.

1. Cut an opening in the enclosure panel for the digital operator as shown in *Figure 2.12*.
2. Mount the digital operator to the installation support.
3. Mount the installation support set and digital operator to the enclosure panel.

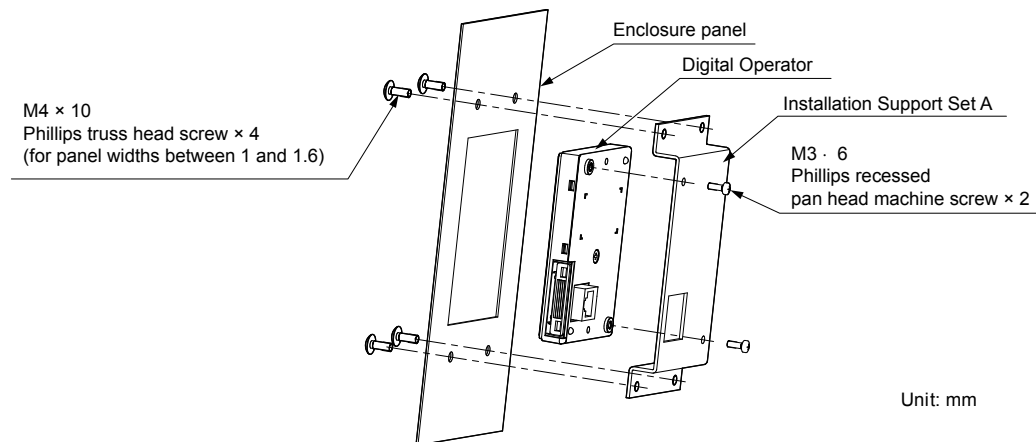

Figure 2.11 Internal/Flush Mount Installation

Note: Use a gasket between the enclosure panel and the digital operator in environments with a significant amount of dust or other airborne debris.

2.2 Mechanical Installation

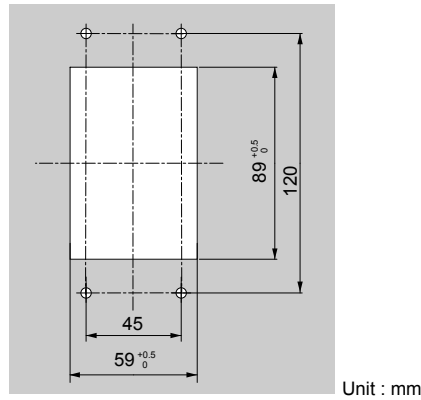

Figure 2.12 Panel Cut-Out Dimensions (Internal/Flush-Mount Installation)

◆ Exterior and Mounting Dimensions

Table 2.4 Drive Models and Types

Protective Design	Drive Model			Page
	Three-Phase 200 V Class	Three-Phase 400 V Class	Three-Phase 600 V Class	
IP20/NEMA Type 1 Enclosure	2A0004F	4A0002F	5A0003F 5A0004F 5A0006F 5A0009F 5A0011F 5A0017F 5A0022F 5A0027F 5A0032F 5A0041F 5A0052F 5A0062F 5A0077F 5A0099F	61
	2A0006F	4A0004F		
	2A0008F	4A0005F		
	2A0010F	4A0007F		
	2A0012F	4A0009F		
	2A0018F	4A0011F		
	2A0021F	4A0018F		
	2A0030F	4A0023F		
	2A0040F	4A0031F		
	2A0056F	4A0038F		
	2A0069F	4A0044F		
	2A0081F	4A0058F		
	2A0110F	4A0072F		
	2A0138F	4A0088F		
	2A0169F	4A0103F		
	2A0211F	4A0139F		
	IP00/Open Type Enclosure			
		4A0250A <1>		
2A0250A <1>		4A0296A <1>		
2A0312A <1>		4A0362A <1>		
2A0360A <1>		4A0414A <2>		
2A0415A <2>		4A0515A <2>		
		4A0675A <2>		
		4A0930A <2>		
		4A1200A <2>		

<1> Customers may convert these models to IP20/NEMA Type 1 enclosures using an IP20/NEMA Type 1 Kit. [Refer to IP20/NEMA Type 1 Kit Selection on page 67](#) to select the appropriate kit.

<2> Contact a Yaskawa representative for IP20/NEMA Type 1 Kit availability for these models.

■ IP20/NEMA Type 1 Enclosure Drives

Note: Removing the top protective cover or bottom conduit bracket from an IP20/NEMA Type 1 enclosure drive voids NEMA Type 1 protection while maintaining IP20 conformity.

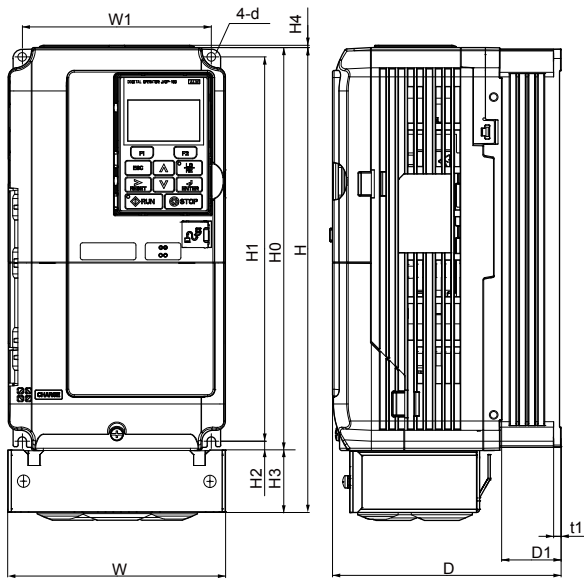

Figure 1

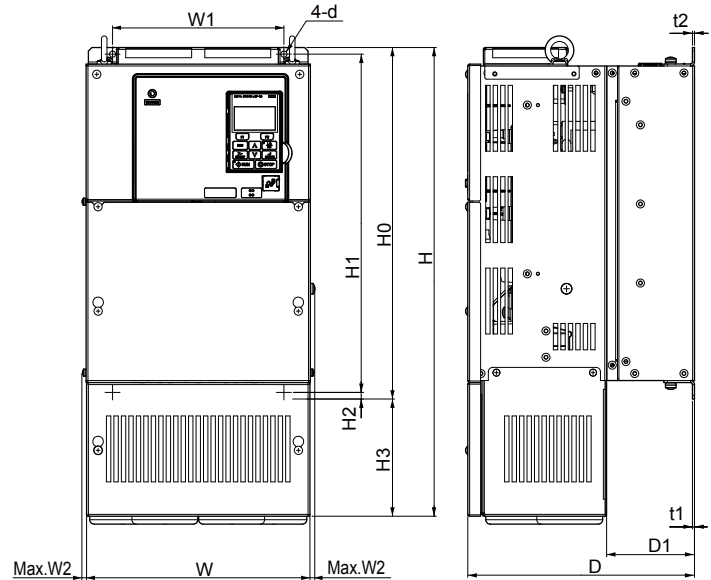

Figure 2

Table 2.5 Dimensions for IP20/NEMA Type 1 Enclosure: 200 V Class

Drive Model	Dimensions (in)																
	Figure	W	H	D	W1	W2	H0	H1	H2	H3	H4	D1	t1	t2	d	Wt. (lb)	
2A0004F	1 </>	5.51	11.81	5.79	4.80	–	10.24	9.76	0.24	1.57	0.06	1.50	0.20	–	M5	7.3	
2A0006F		5.51	11.81	5.79	4.80	–	10.24	9.76	0.24	1.57	0.06	1.50	0.20	–	M5	7.3	
2A0008F		5.51	11.81	5.79	4.80	–	10.24	9.76	0.24	1.57	0.06	1.50	0.20	–	M5	7.5	
2A0010F		5.51	11.81	5.79	4.80	–	10.24	9.76	0.24	1.57	0.06	1.50	0.20	–	M5	7.5	
2A0012F		5.51	11.81	5.79	4.80	–	10.24	9.76	0.24	1.57	0.06	1.50	0.20	–	M5	7.5	
2A0018F		5.51	11.81	6.46	4.80	–	10.24	9.76	0.24	1.57	0.06	2.17	0.20	–	M5	8.2	
2A0021F		5.51	11.81	6.46	4.80	–	10.24	9.76	0.24	1.57	0.06	2.17	0.20	–	M5	8.2	
2A0030F		5.51	11.81	6.57	4.80	–	10.24	9.76	0.24	1.57	0.06	2.17	0.20	–	M5	9.3	
2A0040F		5.51	11.81	6.57	4.80	–	10.24	9.76	0.24	1.57	0.06	2.17	0.20	–	M5	9.3	
2A0056F		7.09	13.39	7.36	6.30	–	11.81	11.18	0.31	1.57	0.06	2.95	0.20	–	M5	13.0	
2A0069F		8.66	15.75	7.76	7.56	–	13.78	13.19	0.31	1.97	0.06	3.07	0.20	–	M6	20.1	
2A0081F		8.66	15.75	7.76	7.56	–	13.78	13.19	0.31	1.97	0.06	3.07	0.20	–	M6	22.0	
2A0110F		2 </>	10.00	21.02	10.16	7.68	0.31	15.75	15.16	0.30	5.28	–	3.94	0.09	0.09	M6	50.7
2A0138F			10.98	24.17	10.16	8.66	0.31	17.72	17.13	0.30	6.46	–	3.94	0.09	0.09	M6	61.7
2A0169F	12.95		28.74	11.14	10.24	0.31	21.65	21.06	0.30	7.09	–	4.33	0.09	0.09	M6	90.4	
2A0211F	12.95		28.74	11.14	10.24	0.31	21.65	21.06	0.30	7.09	–	4.33	0.09	0.09	M6	92.6	
Dimensions below are the dimensions of IP00/Open Type models after customer installation of the appropriate IP20/NEMA Type 1 Kit.																	
2A0250A	2	17.95	37.80	12.99	12.80	0.31	27.76	26.77	0.49	10.04	–	5.12	0.13	0.13	M10	183.0	
2A0312A		17.95	37.80	12.99	12.80	0.31	27.76	26.77	0.49	10.04	–	5.12	0.13	0.13	M10	194.0	
2A0360A		19.84	45.98	13.78	14.57	0.31	31.50	30.43	0.51	14.49	–	5.12	0.18	0.18	M12	238.1	

<1> Removing the top protective cover from a IP20/NEMA Type 1 enclosure drive voids NEMA Type 1 protection while retaining IP20 conformity.

2.2 Mechanical Installation

Table 2.6 Dimensions for IP20/NEMA Type 1 Enclosure: 400 V Class

Drive Model	Dimensions (in)															
	Figure	W	H	D	W1	W2	H0	H1	H2	H3	H4	D1	t1	t2	d	Wt. (lb)
4A0002F	<1>	5.51	11.81	5.79	4.80	–	10.24	9.76	0.24	1.57	0.06	1.50	0.20	–	M5	7.5
4A0004F		5.51	11.81	5.79	4.80	–	10.24	9.76	0.24	1.57	0.06	1.50	0.20	–	M5	7.5
4A0005F		5.51	11.81	5.79	4.80	–	10.24	9.76	0.24	1.57	0.06	1.50	0.20	–	M5	7.5
4A0007F		5.51	11.81	6.46	4.80	–	10.24	9.76	0.24	1.57	0.06	2.17	0.20	–	M5	7.9
4A0009F		5.51	11.81	6.46	4.80	–	10.24	9.76	0.24	1.57	0.06	2.17	0.20	–	M5	8.2
4A0011F		5.51	11.81	6.46	4.80	–	10.24	9.76	0.24	1.57	0.06	2.17	0.20	–	M5	8.2
4A0018F		5.51	11.81	6.57	4.80	–	10.24	9.76	0.24	1.57	0.06	2.17	0.20	–	M5	9.0
4A0023F		5.51	11.81	6.57	4.80	–	10.24	9.76	0.24	1.57	0.06	2.17	0.20	–	M5	9.0
4A0031F		7.09	13.39	6.57	6.30	–	11.81	11.18	0.31	1.57	0.06	2.17	0.20	–	M5	12.6
4A0038F		7.09	13.39	7.36	6.30	–	11.81	11.18	0.31	1.57	0.06	2.95	0.20	–	M5	13.2
4A0044F		8.66	15.75	7.76	7.56	–	13.78	13.19	0.31	1.97	0.06	3.07	0.20	–	M6	19.2
4A0058F		<2>	10.00	18.31	10.16	7.68	0.31	15.75	15.16	0.30	2.56	–	3.94	0.09	0.09	M6
4A0072F	10.98		20.28	10.16	8.66	0.31	17.72	17.13	0.30	2.56	–	3.94	0.09	0.09	M6	59.5
4A0088F	12.95		24.80	10.16	10.24	0.31	20.08	19.49	0.30	4.72	–	4.13	0.09	0.13	M6	86.0
4A0103F	12.95		24.80	10.16	10.24	0.31	20.08	19.49	0.30	4.72	–	4.13	0.09	0.13	M6	86.0
4A0139F	12.95		28.74	11.14	10.24	0.31	21.65	21.06	0.30	7.09	–	4.33	0.09	0.09	M6	99.2
4A0165F	12.95		28.74	11.14	10.24	0.31	21.65	21.06	0.30	7.09	–	4.33	0.09	0.09	M6	101.4
Dimensions below are the dimensions of IP00/Open Type models after customer installation of the appropriate IP20/NEMA Type 1 Kit.																
4A0208A	<2>	17.95	37.80	12.99	12.80	0.31	27.76	26.77	0.49	10.04	–	5.12	0.13	0.13	M10	191.8
4A0250A		19.84	45.98	13.78	14.57	0.31	31.50	30.43	0.51	14.49	–	5.12	0.18	0.18	M12	233.7
4A0296A		19.84	45.98	13.78	14.57	0.31	31.50	30.43	0.51	14.49	–	5.12	0.18	0.18	M12	246.9
4A0362A		19.84	45.98	13.78	14.57	0.31	31.50	30.43	0.51	14.49	–	5.12	0.18	0.18	M12	257.9

<1> Removing the top protective cover from a IP20/NEMA Type 1 enclosure drive voids NEMA Type 1 protection while retaining IP20 conformity.

Table 2.7 Dimensions for IP20/NEMA Type 1 Enclosure: 600 V Class

Drive Model	Dimensions (in)																
	Figure	W	H	D	W1	W2	H0	H1	H2	H3	H4	D1	t1	t2	d	Wt. (lb)	
5A0003F	<1>	5.51	11.81	5.79	4.80	–	10.24	9.76	0.24	1.57	0.06	1.50	0.20	–	M5	7.5	
5A0004F		5.51	11.81	5.79	4.80	–	10.24	9.76	0.24	1.57	0.06	1.50	0.20	–	M5	7.5	
5A0006F		5.51	11.81	6.46	4.80	–	10.24	9.76	0.24	1.57	0.06	2.17	0.20	–	M5	8.2	
5A0009F		5.51	11.81	6.46	4.80	–	10.24	9.76	0.24	1.57	0.06	2.17	0.20	–	M5	8.2	
5A0011F		5.51	11.81	6.57	4.80	–	10.24	9.76	0.24	1.57	0.06	2.17	0.20	–	M5	9.0	
5A0017F		7.09	13.39	7.36	6.30	–	11.81	11.18	0.31	1.57	0.06	2.95	0.20	–	M5	13.2	
5A0022F		7.09	13.39	7.36	6.30	–	11.81	11.18	0.31	1.57	0.06	2.95	0.20	–	M5	13.2	
5A0027F		8.66	15.75	7.76	7.56	–	13.78	13.19	0.31	1.97	0.06	3.07	0.20	–	M6	19.2	
5A0032F		8.66	15.75	7.76	7.56	–	13.78	13.19	0.31	1.97	0.06	3.07	0.20	–	M6	19.2	
5A0041F		<2>	10.98	20.28	10.16	8.66	0.31	17.72	17.13	0.30	2.56	–	3.94	0.09	0.09	M6	59.5
5A0052F			10.98	20.28	10.16	8.66	0.31	17.72	17.13	0.30	2.56	–	3.94	0.09	0.09	M6	59.5
5A0062F			12.95	28.74	11.14	10.24	0.31	21.65	21.06	0.30	7.09	–	4.33	0.09	0.09	M6	99.2
5A0077F	12.95		28.74	11.14	10.24	0.31	21.65	21.06	0.30	7.09	–	4.33	0.09	0.09	M6	99.2	
5A0099F	12.95		28.74	11.14	10.24	0.31	21.65	21.06	0.30	7.09	–	4.33	0.09	0.09	M6	99.2	
Dimensions below are the dimensions of IP00/Open Type models after customer installation of the appropriate IP20/NEMA Type 1 Kit.																	
5A0125A	<2>	17.95	37.80	12.99	12.80	0.31	27.76	26.77	0.49	10.04	–	5.12	0.13	0.13	M10	191.8	
5A0145A		17.95	37.80	12.99	12.80	0.31	27.76	26.77	0.49	10.04	–	5.12	0.13	0.13	M10	191.8	
5A0192A		19.84	45.98	13.78	14.57	0.31	31.50	30.43	0.51	14.49	–	5.12	0.18	0.18	M12	233.7	
5A0242A		19.84	45.98	13.78	14.57	0.31	31.50	30.43	0.51	14.49	–	5.12	0.18	0.18	M12	257.9	

<1> Removing the top protective cover or bottom conduit bracket from an IP20/NEMA Type 1 enclosure drive voids NEMA Type 1 protection while maintaining IP20 conformity.

IP20/NEMA Type 1 Enclosure Conduit Bracket Dimensions

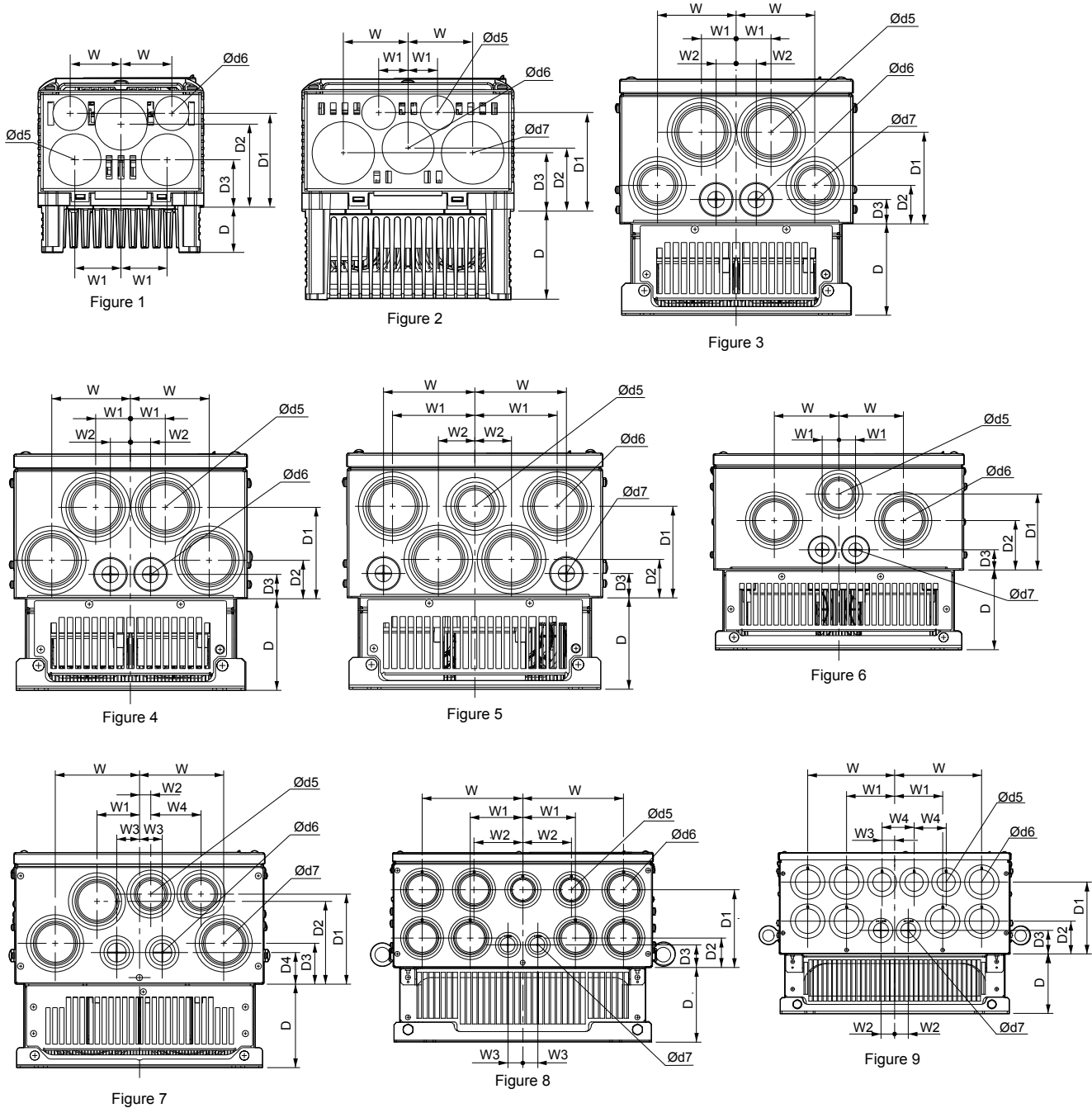

Table 2.8 Conduit Bracket Dimensions for IP20/NEMA Type 1

Drive Model	Dimensions (in)											Diameter (in)		
	Figure	W	D	W1	W2	W3	W4	D1	D2	D3	D4	d5	d6	d7
200 V Class														
2A0004F	1	1.7	1.5	1.5	–	–	–	1.6	2.8	3.1	–	0.9	1.4	–
2A0006F		1.7	1.5	1.5	–	–	–	1.6	2.8	3.1	–	0.9	1.4	–
2A0008F		1.7	1.5	1.5	–	–	–	1.6	2.8	3.1	–	–	–	–
2A0010F		1.7	1.5	1.5	–	–	–	1.6	2.8	3.1	–	0.9	1.4	–
2A0012F		1.7	2.2	1.5	–	–	–	1.6	2.8	3.1	–	0.9	1.4	–

2.2 Mechanical Installation

Drive Model	Dimensions (in)											Diameter (in)		
	Figure	W	D	W1	W2	W3	W4	D1	D2	D3	D4	d5	d6	d7
2A0018F	2	1.7	2.2	1.5	–	–	–	1.6	2.8	3.1	–	1.4	0.9	1.7
2A0021F		1.7	2.2	1.5	–	–	–	1.6	2.8	3.1	–	1.4	0.9	1.7
2A0030F		1.7	2.2	1.5	–	–	–	1.6	2.8	3.1	–	1.4	0.9	1.7
2A0040F		1	3	2.2	–	–	–	1.9	3.3	2.1	–	1.4	0.9	1.7
2A0056F		1	3	2.2	–	–	–	1.9	3.3	2.1	–	1.4	0.9	1.7
2A0069F		1.1	3.1	2.5	–	–	–	2	3.4	2.2	–	1.4	0.9	1.7
2A0081F		1.1	3.1	2.5	–	–	–	2	3.4	2.2	–	1.4	0.9	1.7
2A0110F	4	3.4	3.9	1.5	0.9	–	–	3.9	1.7	1.0	–	2.4	1.1	–
2A0138F	5	3.9	3.9	3.5	1.6	–	–	3.9	1.7	1.0	–	2.0	2.4	1.1
2A0169F	7	4.4	4.3	2.2	0.6	1.2	2.6	4.7	4.3	2.1	1.6	2.0	1.4	2.4
2A0211F		4.4	4.3	2.2	0.6	1.2	2.6	4.7	4.3	2.1	1.6	2.0	1.4	2.4
2A0250A	8	6.9	5.1	3.6	3.3	1.0	–	5.4	2.0	1.6	–	2.0	2.4	1.4
2A0312A		6.9	5.1	3.6	3.3	1.0	–	5.4	2.0	1.6	–	2.0	2.4	1.4
2A0360A	9	7.5	5.1	4.1	1.2	1.1	2.8	6.2	2.8	2.0	–	2.0	2.4	1.7
400 V Class														
4A0002F	1	1.7	1.5	1.5	–	–	–	1.6	2.8	3.1	–	0.9	1.4	–
4A0004F		1.7	1.5	1.5	–	–	–	1.6	2.8	3.1	–	0.9	1.4	–
4A0005F		1.7	1.5	1.5	–	–	–	1.6	2.8	3.1	–	0.9	1.4	–
4A0007F		1.7	2.2	1.5	–	–	–	1.6	2.8	3.1	–	0.9	1.4	–
4A0009F		1.7	2.2	1.5	–	–	–	1.6	2.8	3.1	–	0.9	1.4	–
4A0011F		1.7	2.2	1.5	–	–	–	1.6	2.8	3.1	–	0.9	1.4	–
4A0018F		1.7	2.2	1.5	–	–	–	1.6	2.8	3.1	–	0.9	1.4	–
4A0023F	2	1	3	2.2	–	–	–	1.9	3.3	2.1	–	1.4	0.9	1.7
4A0031F		1	3	2.2	–	–	–	1.9	3.3	2.1	–	1.4	0.9	1.7
4A0038F		1.1	3.1	2.5	–	–	–	2	3.4	2.2	–	1.4	0.9	1.7
4A0044F		1.1	3.1	2.5	–	–	–	2	3.4	2.2	–	1.4	0.9	1.7
4A0058F	3	3.4	3.9	1.5	0.9	–	–	3.9	1.7	1.0	–	2.4	1.1	2.0
4A0072F		3.5	3.9	1.6	0.9	–	–	3.9	1.7	1.0	–	2.4	1.1	2.0
4A0088F	6	3.3	4.1	0.9	–	–	–	3.9	2.6	1.0	–	2.0	2.4	1.1
4A0103F		3.3	4.1	0.9	–	–	–	3.9	2.6	1.0	–	2.0	2.4	1.1
4A0139F	7	4.4	4.3	2.2	0.6	1.2	2.6	4.7	4.3	2.1	1.6	2.0	1.4	2.4
4A0165F		4.4	4.3	2.2	0.6	1.2	2.6	4.7	4.3	2.1	1.6	2.0	1.4	2.4
4A0208A	8	6.9	5.1	3.6	3.3	1.0	–	5.4	2.0	1.6	–	2.0	2.4	1.4
4A0250A	9	7.5	5.1	4.1	1.2	1.1	2.8	6.2	2.8	2.0	–	2.0	2.4	1.7
4A0296A		7.5	5.1	4.1	1.2	1.1	2.8	6.2	2.8	2.0	–	2.0	2.4	1.7
4A0362A		7.5	5.1	4.1	1.2	1.1	2.8	6.2	2.8	2.0	–	2.0	2.4	1.7
600 V Class														
5A0003F	1	1.7	1.5	1.5	–	–	–	1.6	2.8	3.1	–	0.9	1.4	–
5A0004F		1.7	1.5	1.5	–	–	–	1.6	2.8	3.1	–	0.9	1.4	–
5A0006F		1.7	2.2	1.5	–	–	–	1.6	2.8	3.1	–	0.9	1.4	–
5A0009F		1.7	2.2	1.5	–	–	–	1.6	2.8	3.1	–	0.9	1.4	–
5A0011F		1.7	2.2	1.5	–	–	–	1.6	2.8	3.1	–	0.9	1.4	–

Drive Model	Dimensions (in)											Diameter (in)		
	Figure	W	D	W1	W2	W3	W4	D1	D2	D3	D4	d5	d6	d7
5A0017F	2	1	3	2.2	–	–	–	1.9	3.3	2.1	–	1.4	0.9	1.7
5A0022F		1	3	2.2	–	–	–	1.9	3.3	2.1	–	1.4	0.9	1.7
5A0027F		1.1	3.1	2.5	–	–	–	2	3.4	2.2	–	1.4	0.9	1.7
5A0032F		1.1	3.1	2.5	–	–	–	2	3.4	2.2	–	1.4	0.9	1.7
5A0041F	3	3.5	3.9	1.6	0.9	–	–	3.9	1.7	1.0	–	2.4	1.1	2.0
5A0052F		3.5	3.9	1.6	0.9	–	–	3.9	1.7	1.0	–	2.4	1.1	2.0
5A0062F	7	4.4	4.3	2.2	0.6	1.2	2.6	4.7	4.3	2.1	1.6	2.0	1.4	2.4
5A0077F		4.4	4.3	2.2	0.6	1.2	2.6	4.7	4.3	2.1	1.6	2.0	1.4	2.4
5A0099F		4.4	4.3	2.2	0.6	1.2	2.6	4.7	4.3	2.1	1.6	2.0	1.4	2.4
5A0125A	8	6.9	5.1	3.6	3.3	1.0	–	5.4	2.0	1.6	–	2.0	2.4	1.4
5A0145A		6.9	5.1	3.6	3.3	1.0	–	5.4	2.0	1.6	–	2.0	2.4	1.4
5A0192A	9	7.5	5.1	4.1	1.2	1.1	2.8	6.2	2.8	2.0	–	2.0	2.4	1.7
5A0242A		7.5	5.1	4.1	1.2	1.1	2.8	6.2	2.8	2.0	–	2.0	2.4	1.7

Note: Removing the top protective cover or bottom conduit bracket from an IP20/NEMA Type 1 enclosure drive voids NEMA Type 1 protection while maintaining IP20 conformity.

■ IP00/Open Type Enclosure Drives

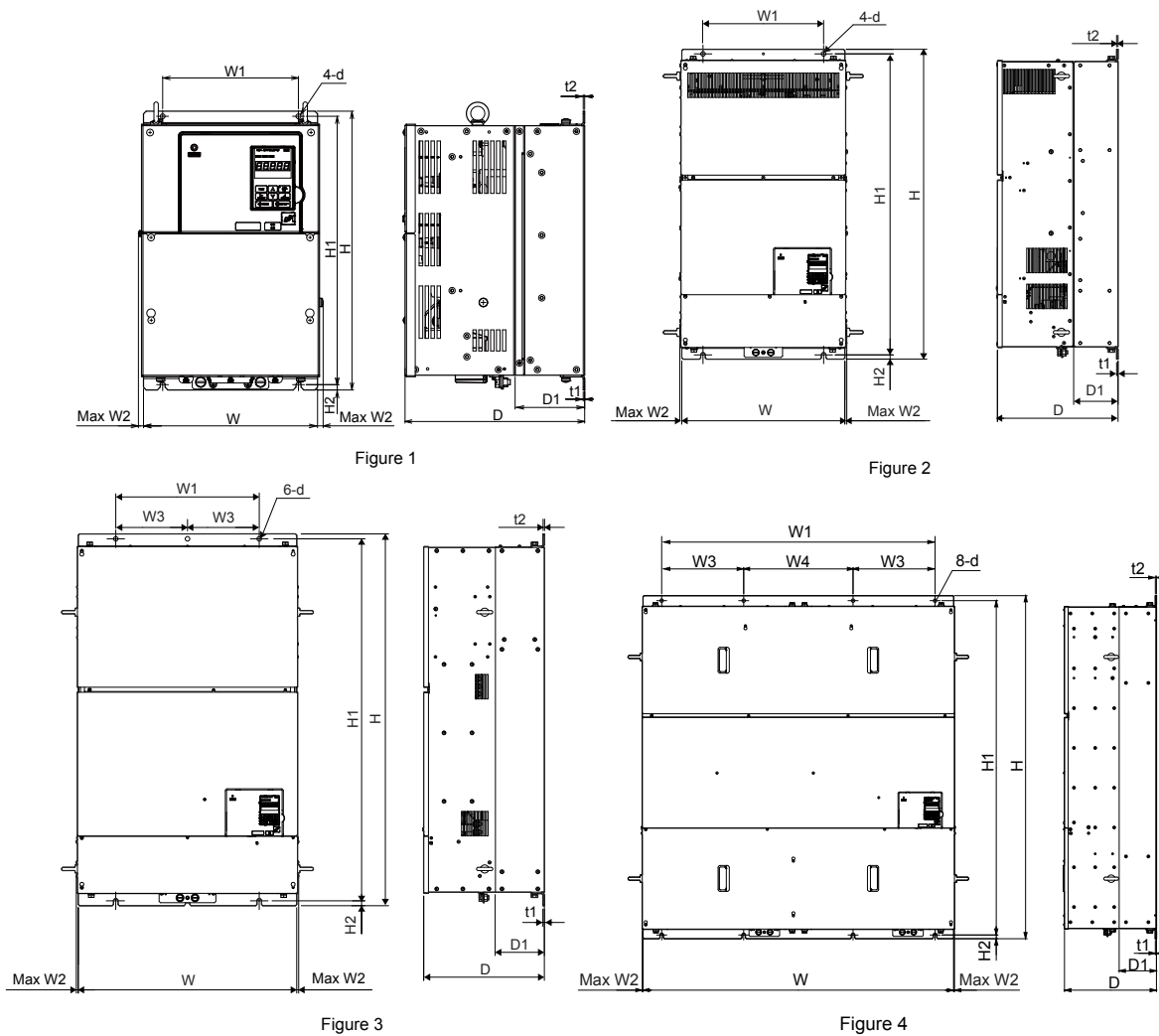

2.2 Mechanical Installation

Table 2.9 Dimensions for IP00/Open Type Enclosure: 200 V Class

Drive Model	Dimensions (in)												
	Figure	W	H	D	W1	W2	H1	H2	D1	t1	t2	d	Wt. (lb)
2A0250A <>	1	17.72	27.76	12.99	12.80	0.39	26.77	0.49	5.12	0.13	0.13	M10	167.6
2A0312A <>		17.72	27.76	12.99	12.80	0.39	26.77	0.49	5.12	0.13	0.13	M10	176.4
2A0360A <>		19.69	31.50	13.78	14.57	0.39	30.43	0.51	5.12	0.18	0.18	M12	216.1
2A0415A		19.69	31.50	13.78	14.57	0.39	30.43	0.51	5.12	0.18	0.18	M12	218.3

<1> Customers may convert these models to IP20/NEMA Type 1 enclosures using an IP20/NEMA Type 1 Kit. [Refer to IP20/NEMA Type 1 Kit Selection on page 67](#) to select the appropriate kit.

Table 2.10 Dimensions for IP00/Open Type Enclosure: 400 V Class

Drive Model	Dimensions (in)														
	Figure	W	H	D	W1	W2	W3	W4	H1	H2	D1	t1	t2	d	Wt. (lb)
4A0208A <>	1	17.72	27.76	12.99	12.80	0.39	–	–	26.77	0.49	5.12	0.13	0.13	M10	174.2
4A0250A <>		19.69	31.50	13.78	14.57	0.39	–	–	30.43	0.51	5.12	0.18	0.18	M12	211.6
4A0296A <>		19.69	31.50	13.78	14.57	0.39	–	–	30.43	0.51	5.12	0.18	0.18	M12	224.9
4A0362A <>		19.69	31.50	13.78	14.57	0.39	–	–	30.43	0.51	5.12	0.18	0.18	M12	235.9
4A0414A	2	19.69	37.40	14.57	14.57	0.31	–	–	36.34	0.51	5.31	0.18	0.18	M12	275.6
4A0515A	3	26.38	44.88	14.57	17.32	0.24	8.66	–	43.70	0.59	5.91	0.18	0.18	M12	476.2
4A0675A		26.38	44.88	14.57	17.32	0.24	8.66	–	43.70	0.59	5.91	0.18	0.18	M12	487.2
4A0930A	4	49.21	54.33	14.57	43.70	0.24	13.00	17.32	52.95	0.59	5.91	0.18	0.18	M12	1201.5
4A1200A		49.21	54.33	14.57	43.70	0.24	13.00	17.32	52.95	0.59	5.91	0.18	0.18	M12	1223.6

<1> Customers may convert these models to IP20/NEMA Type 1 enclosures using an IP20/NEMA Type 1 Kit. [Refer to IP20/NEMA Type 1 Kit Selection on page 67](#) to select the appropriate kit.

Table 2.11 Dimensions for IP00/Open Type Enclosure: 600 V Class

Drive Model	Dimensions (in)														
	Figure	W	H	D	W1	W2	W3	W4	H1	H2	D1	t1	t2	d	Wt. (lb)
5A0125A <>	1	17.72	27.76	12.99	12.80	0.39	–	–	26.77	0.49	5.12	0.13	0.13	M10	174.2
5A0145A <>		17.72	27.76	12.99	12.80	0.39	–	–	26.77	0.49	5.12	0.13	0.13	M10	174.2
5A0192A <>		19.69	31.50	13.78	14.57	0.39	–	–	30.43	0.51	5.12	0.18	0.18	M12	235.9
5A0242A <>		19.69	31.50	13.78	14.57	0.39	–	–	30.43	0.51	5.12	0.18	0.18	M12	235.9

<1> Customers may convert these models to IP20/NEMA Type 1 enclosures using an IP20/NEMA Type 1 Kit. [Refer to IP20/NEMA Type 1 Kit Selection on page 67](#) to select the appropriate kit.

IP20/NEMA Type 1 Kit Selection

Customers may convert IP00/Open Type models to IP20/NEMA Type 1 enclosures. Refer to [Table 2.12](#) to select the appropriate IP20/NEMA Type 1 Kit when performing the conversion.

Contact a Yaskawa representative for IP20/NEMA Type 1 Kit availability for IP00/Open Type models not listed.

Table 2.12 IP20/NEMA Type 1 Kit Selection

IP00/Open Type Drive Model	IP20/NEMA Type 1 Kit Code	Comments
2A0250A	100-054-503	<i>Refer to IP20/NEMA Type 1 Enclosure Drives on page 61</i> for drive dimensions with the IP20/NEMA Type 1 Kit installed.
2A0312A		
2A0360A		
4A0208A		
4A0250A	100-054-504	
4A0296A		
4A0362A		
5A0125A	100-054-503	
5A0145A		
5A0192A	100-054-504	
5A0242A		

This Page Intentionally Blank

Electrical Installation

This chapter explains proper procedures for wiring the control circuit terminals, motor, and power supply.

3.1	SECTION SAFETY.....	70
3.2	STANDARD CONNECTION DIAGRAM.....	72
3.3	MAIN CIRCUIT CONNECTION DIAGRAM.....	75
3.4	TERMINAL BLOCK CONFIGURATION.....	79
3.5	TERMINAL COVER.....	81
3.6	DIGITAL OPERATOR AND FRONT COVER.....	83
3.7	TOP PROTECTIVE COVER.....	86
3.8	MAIN CIRCUIT WIRING.....	87
3.9	CONTROL CIRCUIT WIRING.....	98
3.10	CONTROL I/O CONNECTIONS.....	104
3.11	CONNECT TO A PC.....	108
3.12	EXTERNAL INTERLOCK.....	109
3.13	WIRING CHECKLIST.....	110

3.1 Section Safety

DANGER

Electrical Shock Hazard

Do not connect or disconnect wiring while the power is on.

Failure to comply will result in death or serious injury.

WARNING

Electrical Shock Hazard

Do not operate equipment with covers removed.

Failure to comply could result in death or serious injury.

The diagrams in this section may show drives without covers or safety shields to show details. Be sure to reinstall covers or shields before operating the drives and run the drives according to the instructions described in this manual.

Make sure the protective earthing conductor complies with technical standards and local safety regulations.

Because the leakage current exceeds 3.5 mA in models 4A0414 and larger, IEC 61800-5-1 states that either the power supply must be automatically disconnected in case of discontinuity of the protective earthing conductor or a protective earthing conductor with a cross-section of at least 10 mm² (Cu) or 16 mm² (Al) must be used. Failure to comply may result in death or serious injury.

Always use appropriate equipment for Ground Fault Circuit Interrupters (GFCIs).

The drive can cause a residual current with a DC component in the protective earthing conductor. Where a residual current operated protective or monitoring device is used for protection in case of direct or indirect contact, always use a type B GFCI according to IEC 60755.

Always ground the motor-side grounding terminal.

Improper equipment grounding could result in death or serious injury by contacting the motor case.

Do not perform work on the drive while wearing loose clothing, jewelry or without eye protection.

Failure to comply could result in death or serious injury.

Remove all metal objects such as watches and rings, secure loose clothing, and wear eye protection before beginning work on the drive.

Do not remove covers or touch circuit boards while the power is on.

Failure to comply could result in death or serious injury.

Do not allow unqualified personnel to perform work on the drive.

Failure to comply could result in death or serious injury.

Installation, maintenance, inspection, and servicing must be performed only by authorized personnel familiar with installation, adjustment, and maintenance of AC drives.

Do not touch any terminals before the capacitors have fully discharged.

Failure to comply could result in death or serious injury.

Before wiring terminals, disconnect all power to the equipment. The internal capacitor remains charged even after the power supply is turned off. After shutting off the power, wait for at least the amount of time specified on the drive before touching any components.

Fire Hazard

Tighten all terminal screws to the specified tightening torque.

Loose electrical connections could result in death or serious injury by fire due to overheating of electrical connections.

Do not use improper combustible materials.

Failure to comply could result in death or serious injury by fire.

Do not install the drive to a combustible surface. Never place combustible materials on the drive.

⚠ WARNING**Do not use an improper voltage source.**

Failure to comply could result in death or serious injury by fire.

Verify that the rated voltage of the drive matches the voltage of the incoming power supply before applying power.

When installing dynamic braking options, perform all wiring exactly as specified in the wiring diagrams provided.

Failure to do so can result in fire. Improper wiring may damage braking components.

⚠ CAUTION**Do not carry the drive by the front cover or the terminal cover.**

Failure to comply may cause the main body of the drive to fall, resulting in minor or moderate injury.

NOTICE**Observe proper electrostatic discharge procedures (ESD) when handling the drive and circuit boards.**

Failure to comply may result in ESD damage to the drive circuitry.

Never connect or disconnect the motor from the drive while the drive is outputting voltage.

Improper equipment sequencing could result in damage to the drive.

Do not use unshielded cable for control wiring.

Failure to comply may cause electrical interference resulting in poor system performance. Use shielded, twisted-pair wires and ground the shield to the ground terminal of the drive.

Do not allow unqualified personnel to use the product.

Failure to comply could result in damage to the drive or braking circuit.

Carefully review instruction manual TOBPC72060000 or TOBPC72060001 when connecting a dynamic braking option to the drive.

Do not modify the drive circuitry.

Failure to comply could result in damage to the drive and will void warranty.

Yaskawa is not responsible for any modification of the product made by the user. This product must not be modified.

Check all the wiring to ensure that all connections are correct after installing the drive and connecting any other devices.

Failure to comply could result in damage to the drive.

3.2 Standard Connection Diagram

Connect the drive and peripheral devices as shown in [Figure 3.1](#). It is possible to set and run the drive via the digital operator without connecting digital I/O wiring. This section does not discuss drive operation; [Refer to Start-Up Programming & Operation on page 113](#) for instructions on operating the drive.

NOTICE: *Inadequate wiring could result in damage to the drive. Install adequate branch circuit short circuit protection per applicable codes. The drive is suitable for circuits capable of delivering not more than 100,000 RMS symmetrical amperes, 240 Vac maximum (200 V class), 480 Vac maximum (400 V class), 600 Vac maximum (600 V class).*

NOTICE: *When the input voltage is 440 V or higher or the wiring distance is greater than 100 meters, pay special attention to the motor insulation voltage or use a drive duty motor. Failure to comply could lead to motor insulation breakdown.*

NOTICE: *Do not connect AC control circuit ground to drive enclosure. Improper drive grounding can cause control circuit malfunction.*

Note: The minimum load for the relay outputs M1-M2, M3-M4, M5-M6, and MA-MB-MC is 10 mA.

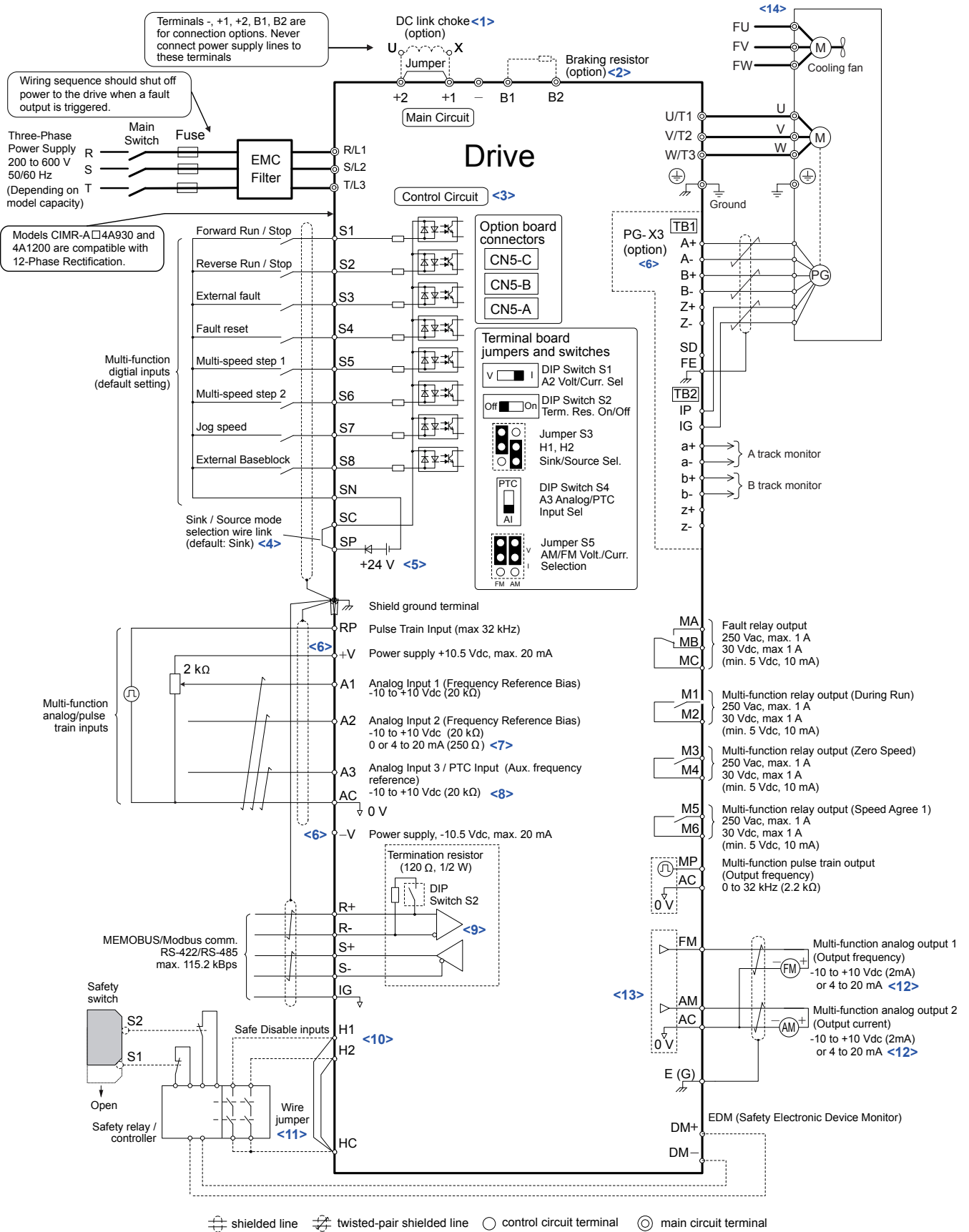

Figure 3.1 Drive Standard Connection Diagram (example: model 2A0040)

<1> Remove the jumper when installing a DC link choke. Models 2A0110 to 2A0415 and 4A0058 to 4A1200 come with a built-in DC link choke.

3.2 Standard Connection Diagram

- <2> Set L8-55 to 0 to disable the protection function of the built-in braking transistor of the drive when using an optional regenerative converter or dynamic braking option. Leaving L8-55 enabled may cause a braking resistor fault (rF). Additionally, disable Stall Prevention (L3-04 = 0) when using an optional regenerative converter, regenerative or braking units, or dynamic braking option. Leaving L3-04 enabled may prevent the drive from stopping within the specified deceleration time.
- <3> Supplying power to the control circuit separately from the main circuit requires 24 V power supply (option).
- <4> This figure illustrates an example of a sequence input to S1 through S8 using a non-powered relay or an NPN transistor. Install the wire link between terminals SC-SP for Sink mode, between SC-SN for Source mode, or leave the link out for external power supply. Never short terminals SP and SN, as it will damage the drive.
- <5> This voltage source supplies a maximum current of 150 mA when not using a digital input card DI-A3.
- <6> The maximum output current capacity for the +V and -V terminals on the control circuit is 20 mA. Never short terminals +V, -V, and AC, as it can cause erroneous operation or damage the drive.
- <7> Set DIP switch S1 to select between a voltage or current input signal to terminal A2. The default setting is for current input.
- <8> Set DIP switch S4 to select between analog or PTC input for terminal A3.
- <9> Set DIP switch S2 to the ON position to enable the termination resistor in the last drive in a MEMOBUS/Modbus network.
- <10> Use jumper S3 to select between Sink mode, Source mode, and external power supply for the Safe Disable inputs.
NOTE: Terminals H1, H2, DM+, and DM- on 600 V class models are designed to the functionality, but are not certified to EN61800-5-1, ISO13849 Cat. 3, IEC/EN61508 SIL2, Insulation coordination: class 1.
- <11> Disconnect the wire jumper between H1 - HC and H2 - HC when utilizing the Safe Disable input.
NOTE: Terminals H1, H2, DM+, and DM- on 600 V class models are designed to the functionality, but are not certified to EN61800-5-1, ISO13849 Cat. 3, IEC/EN61508 SIL2, Insulation coordination: class 1.
- <12> Monitor outputs work with devices such as analog frequency meters, ammeters, voltmeters, and wattmeters. They are not intended for use as a feedback-type signal.
- <13> Use jumper S5 to select between voltage or current output signals at terminals AM and FM. Set parameters H4-07 and H4-08 accordingly.
- <14> Self-cooling motors do not require the same wiring necessary for motors with cooling fans.

WARNING! Sudden Movement Hazard. Do not close the wiring for the control circuit unless the multifunction input terminal parameters are properly set. Improper sequencing of run/stop circuitry could result in death or serious injury from moving equipment.

WARNING! Sudden Movement Hazard. Ensure start/stop and safety circuits are wired properly and in the correct state before energizing the drive. Failure to comply could result in death or serious injury from moving equipment. When programmed for 3-Wire control, a momentary closure on terminal S1 may cause the drive to start.

WARNING! Sudden Movement Hazard. When using a 3-Wire sequence, set the drive to 3-Wire sequence prior to wiring the control terminals and set parameter b1-17 to 0 so the drive will not accept a Run command at power up (default). If the drive is wired for a 3-Wire sequence but set up for a 2-Wire sequence (default), and parameter b1-17 is set to 1 so the drive accepts a Run command at power up, the motor will rotate in reverse direction at drive power up and may cause injury.

WARNING! Sudden Movement Hazard. Confirm the drive I/O signals and external sequence before executing the application preset function. Executing the application preset function or setting A1-06 ≠ 0 will change the drive I/O terminal functions and may cause unexpected equipment operation. Failure to comply may cause death or serious injury.

NOTICE: When using the automatic fault restart function with wiring designed to shut off the power supply upon drive fault, make sure the drive does not trigger a fault output during fault restart (L5-02 = 0, default). Failure to comply will prevent the automatic fault restart function from working properly.

3.3 Main Circuit Connection Diagram

Refer to diagrams in this section when wiring the main circuit of the drive. Connections may vary based on drive capacity. The DC power supply for the main circuit also provides power to the control circuit.

NOTICE: Do not use the negative DC bus terminal “-” as a ground terminal. This terminal is at high DC voltage potential. Improper wiring connections could damage the drive.

- ◆ **Three-Phase 200 V Class Models 2A0004 to 2A0081**
- Three-Phase 400 V Class Models 4A0002 to 4A0044**
- Three-Phase 600 V Class Models 5A0003 to 5A0032**

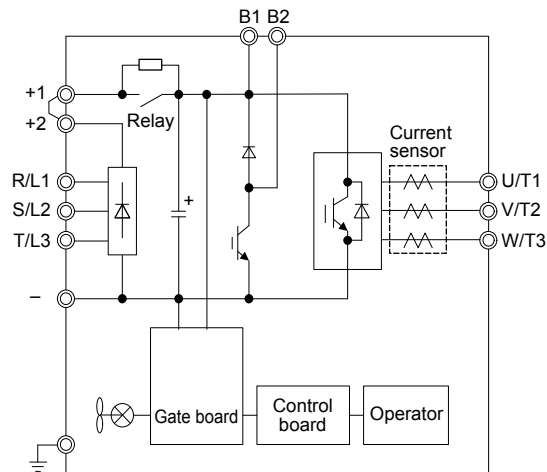

Figure 3.2 Connecting Main Circuit Terminals

- ◆ **Three-Phase 200 V Class Models 2A0110, 2A0138**
- Three-Phase 400 V Class Models 4A0058, 4A0072**
- Three-Phase 600 V Class Models 5A0041, 5A0052**

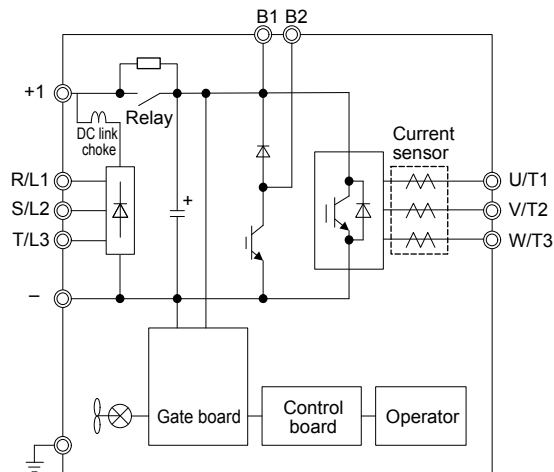

Figure 3.3 Connecting Main Circuit Terminals

3.3 Main Circuit Connection Diagram

- ◆ **Three-Phase 200 V Class Models 2A0169 to 2A0211**
- Three-Phase 400 V Class Models 4A0088 to 4A0139**
- Three-Phase 600 V Class Models 5A0062 to 5A0099**

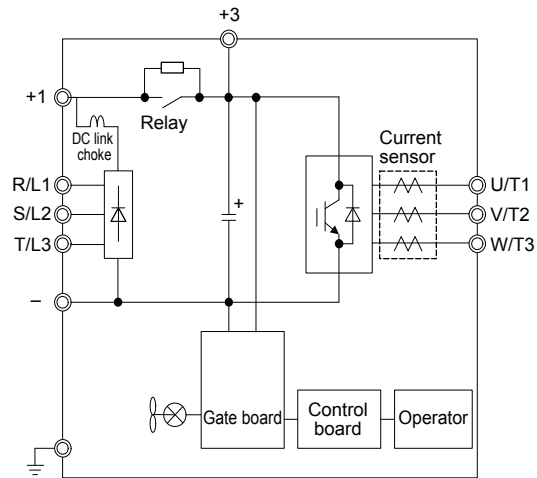

Figure 3.4 Connecting Main Circuit Terminals

- ◆ **Three-Phase 200 V Class Models 2A0250 to 2A0415**
- Three-Phase 400 V Class Models 4A0165 to 4A0675**
- Three-Phase 600 V Class Models 5A0125 to 5A0242**

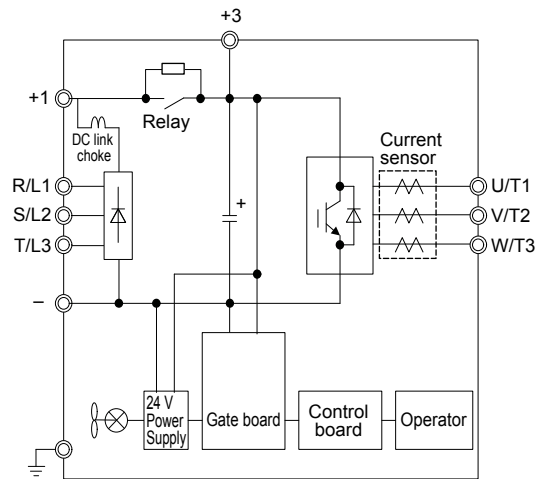

Figure 3.5 Connecting Main Circuit Terminals

◆ Three-Phase 400 V Class Models 4A0930, 4A1200

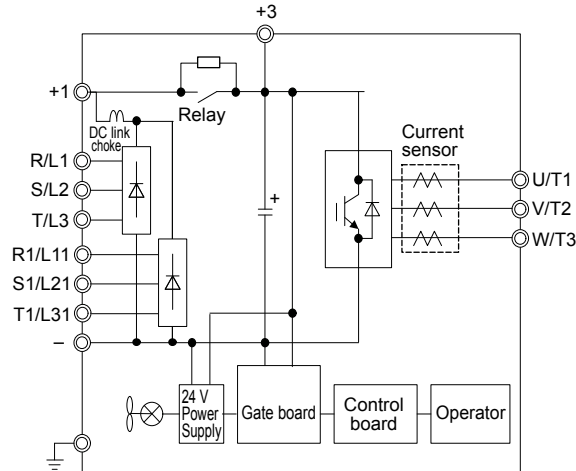

Figure 3.6 Connecting Main Circuit Terminals

Note: Models 4A0930 and 4A1200 are compatible for operation with 12-phase rectification. [Refer to 12-Phase Rectification on page 77](#) for details.

◆ 12-Phase Rectification

■ Removing the Jumper

Models 4A0930 and 4A1200 are compatible for operation with 12-phase rectification. Operation with 12-phase rectification requires the user to separately prepare a 3-winding transformer for the power supply. Contact Yaskawa or your nearest sales representative for transformer specifications.

WARNING! Fire Hazard. Failure to remove jumpers shorting the power supply terminals on the main circuit when operating with 12-phase rectification may cause death or serious injury by fire.

■ Application Notes

Models 4A0930 and 4A1200 are shipped from the factory with jumpers short-circuiting terminals R/L1-R1/L11, S/L2-S1/L21, and T/L3-T1/L31.

Remove M5 screws and jumpers as shown in [Figure 3.7](#) to operate with 12-phase rectification.

3.3 Main Circuit Connection Diagram

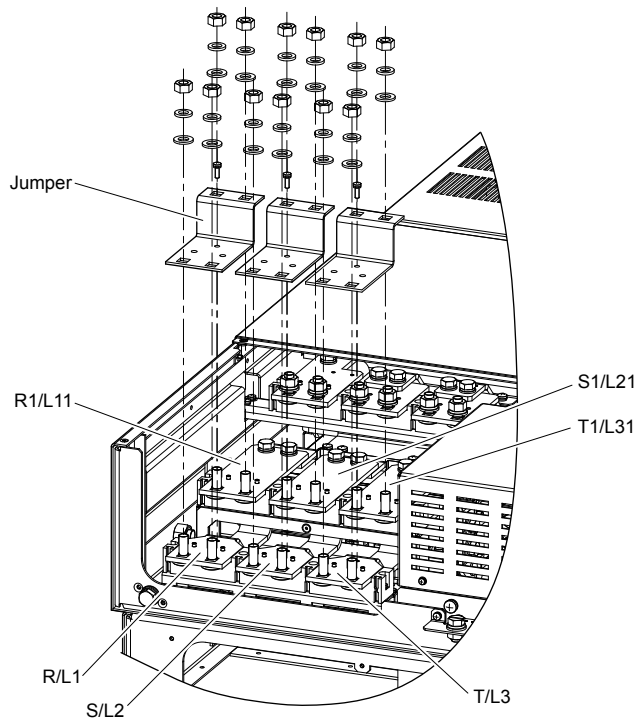

Figure 3.7 Removing the Jumper

■ Connection Diagram

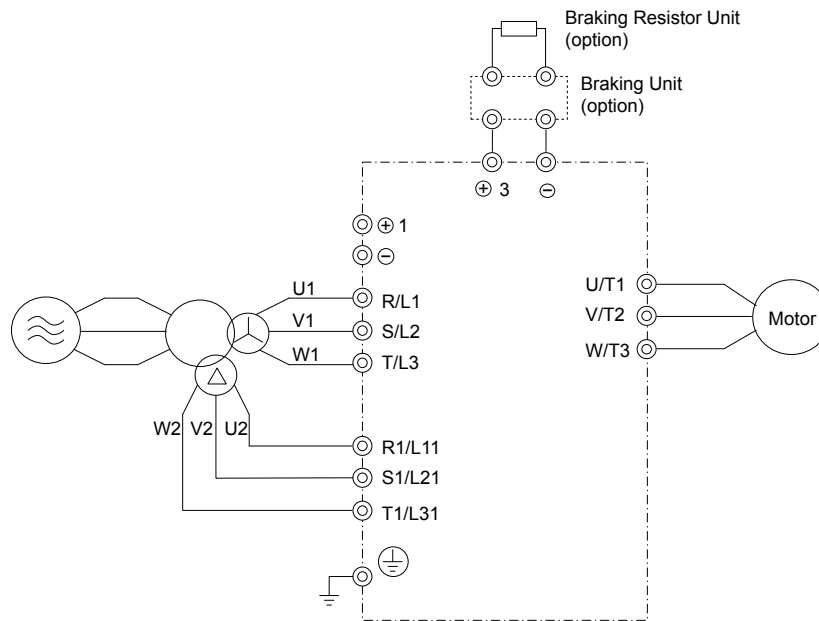

Figure 3.8 Connecting Main Circuit Terminals

3.4 Terminal Block Configuration

Figure 3.9 and Figure 3.10 show the different main circuit terminal arrangements for the drive capacities.

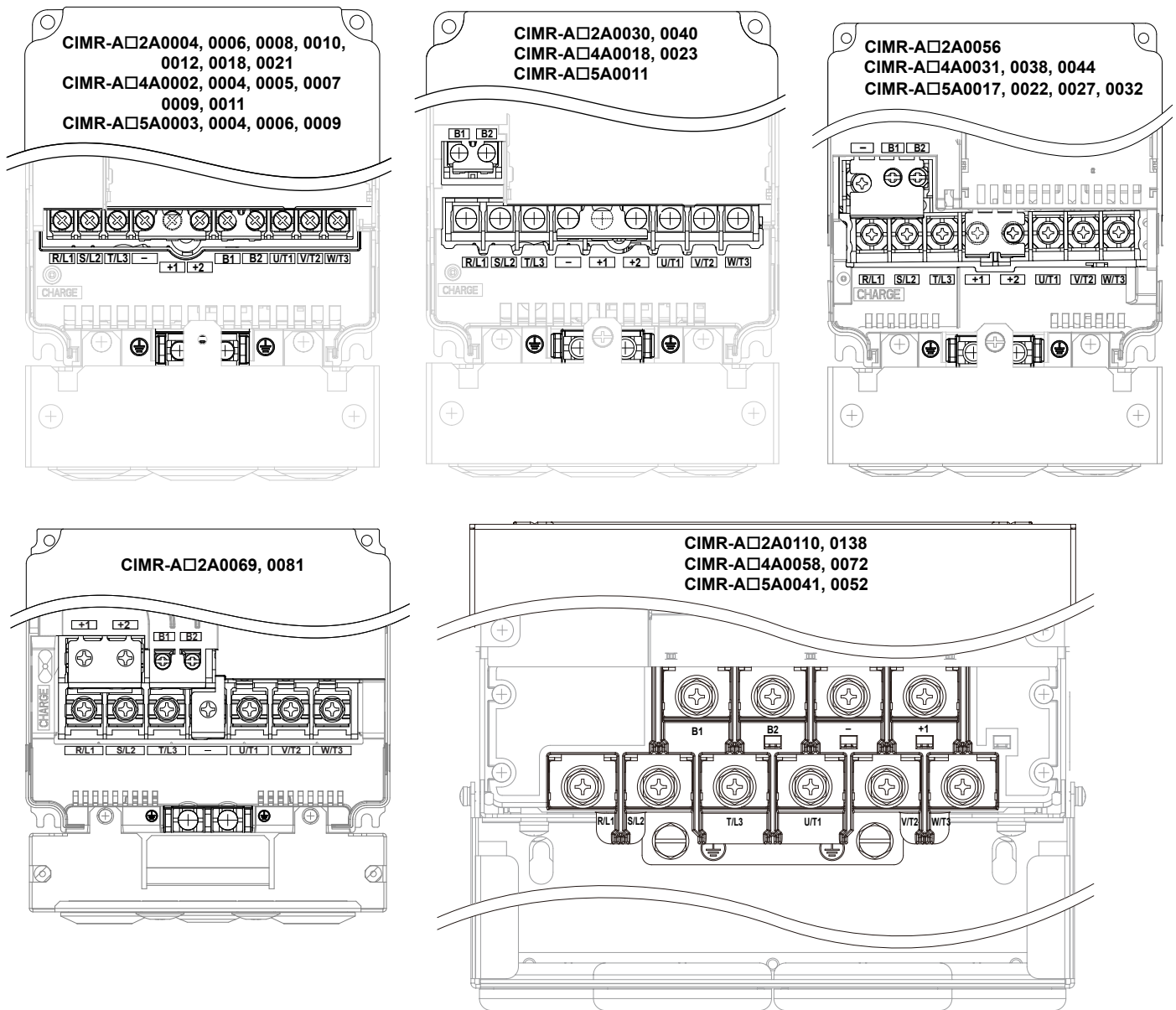

Figure 3.9 Main Circuit Terminal Block Configuration

3.4 Terminal Block Configuration

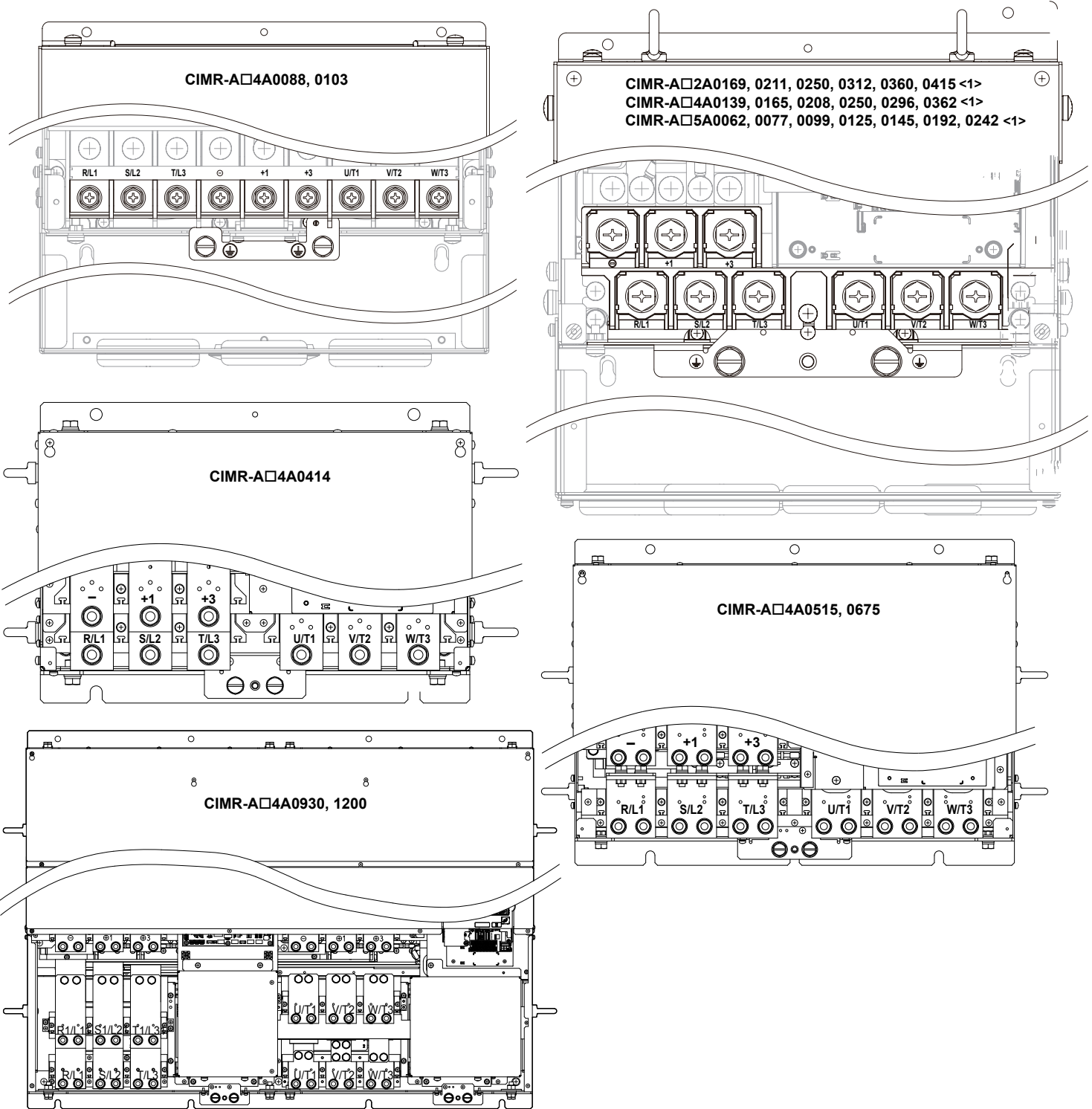

Figure 3.10 Main Circuit Terminal Block Configuration (continued)

<1> Terminal block design differs slightly for models 2A0250 to 2A0415, 4A0208 to 4A0362, and 5A0125 to 5A0242.

3.5 Terminal Cover

Follow the procedure below to remove the terminal cover for wiring and to reattach the terminal cover after wiring is complete.

◆ Models 2A0004 to 2A0081, 4A0002 to 4A0044, 5A0003 to 5A0032 (IP20/NEMA Type 1 Enclosure)

■ Removing the Terminal Cover

1. Loosen the terminal cover screw using a #2 Phillips screwdriver. Screw sizes vary by drive model.

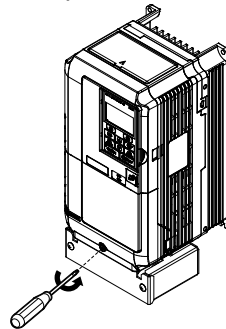

Figure 3.11 Removing the Terminal Cover on an IP20/NEMA Type 1 Enclosure Drive

2. Push in on the tab located on the bottom of the terminal cover and gently pull forward to remove the terminal cover.

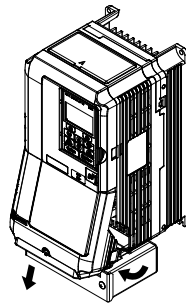

Figure 3.12 Removing the Terminal Cover on an IP20/NEMA Type 1 Enclosure Drive

■ Reattaching the Terminal Cover

Power lines and signal wiring should pass through the opening provided. *Refer to [Wiring the Main Circuit Terminal on page 97](#) and [Wiring the Control Circuit Terminal on page 101](#) for details on wiring.*

Reattach the terminal cover after completing the wiring to the drive and other devices.

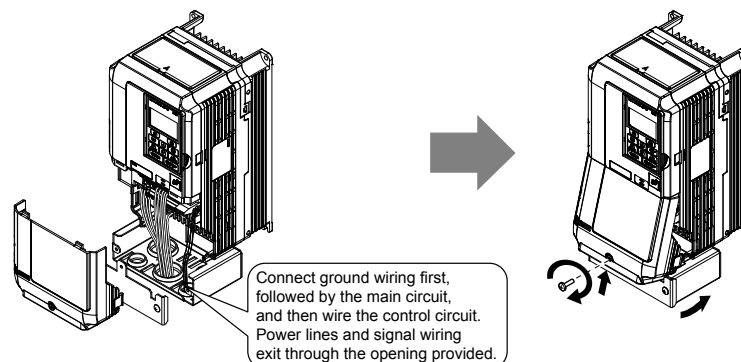

Figure 3.13 Reattaching the Terminal Cover on an IP20/NEMA Type 1 Enclosure Drive

◆ Models 2A0110 to 2A0250, 4A0208 to 4A1200, and 5A0125 to 5A0242 (IP00/Open Type Enclosure)

■ Removing the Terminal Cover

1. Loosen the screws on the terminal cover, then pull down on the cover.

Note: The terminal cover and the number of terminal cover screws differ depending on the drive model. [Refer to Component Names on page 42](#) for details.

CAUTION! Do not completely remove the cover screws, just loosen them. If the cover screws are removed completely, the terminal cover may fall off causing an injury.

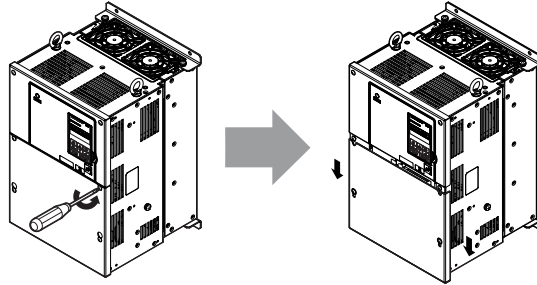

Figure 3.14 Removing the Terminal Cover on an IP00/Open Type Enclosure Drive

2. Pull forward on the terminal cover to free it from the drive.

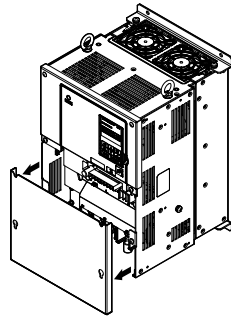

Figure 3.15 Removing the Terminal Cover on an IP00/Open Type Enclosure Drive

■ Reattaching the Terminal Cover

After wiring the terminal board and other devices, double-check connections and reattach the terminal cover. [Refer to Wiring the Main Circuit Terminal on page 97](#) and [Wiring the Control Circuit Terminal on page 101](#) for details on wiring.

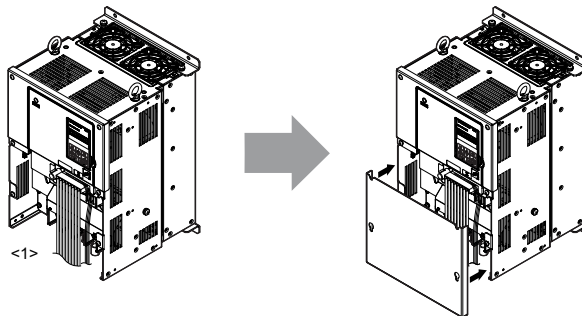

Figure 3.16 Reattaching the Terminal Cover on an IP00/Open Type Enclosure Drive

<1> Connect the ground wiring first, then the main circuit wiring, and finally the control circuit wiring.

3.6 Digital Operator and Front Cover

Detach the digital operator from the drive for remote operation or when opening the front cover to install an option card.

NOTICE: Be sure to remove the digital operator prior to opening or reattaching the front cover. Leaving the digital operator plugged into the drive when removing the front cover can result in erroneous operation caused by a poor connection. Firmly fasten the front cover back into place before reattaching the digital operator.

◆ Removing/Reattaching the Digital Operator

■ Removing the Digital Operator

While pressing on the tab located on the right side of the digital operator, pull the digital operator forward to remove it from the drive.

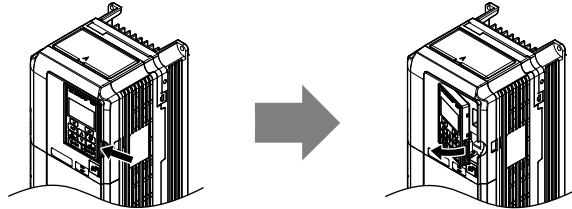

Figure 3.17 Removing the Digital Operator

■ Reattaching the Digital Operator

Insert the digital operator into the opening in the top cover while aligning it with the notches on the left side of the opening. Next, press gently on the right side of the operator until it clicks into place.

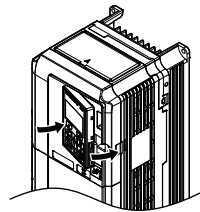

Figure 3.18 Reattaching the Digital Operator

◆ Removing/Reattaching the Front Cover

■ Removing the Front Cover

Models 2A0004 to 2A0081, 4A0002 to 4A0044, and 5A0003 to 5A0032

After removing the terminal cover and the digital operator, loosen the screw that affixes the front cover (models 2A0056, 4A0038, 5A0022, and 5A0027 do not use a screw to affix the front cover). Pinch in on the tabs found on each side of the front cover, then pull forward to remove it from the drive.

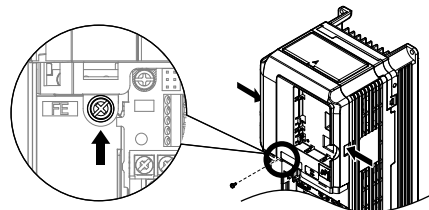

Figure 3.19 Remove the Front Cover (2A0004 to 2A0081, 4A0002 to 4A0044, and 5A0003 to 5A0032)

Models 2A0110 to 2A0415 and 4A0058 to 4A1200

1. Remove the terminal cover and the digital operator.
2. Loosen the installation screw on the front cover.
3. Use a straight-edge screwdriver to loosen the hooks on each side of the cover that hold it in place.

3.6 Digital Operator and Front Cover

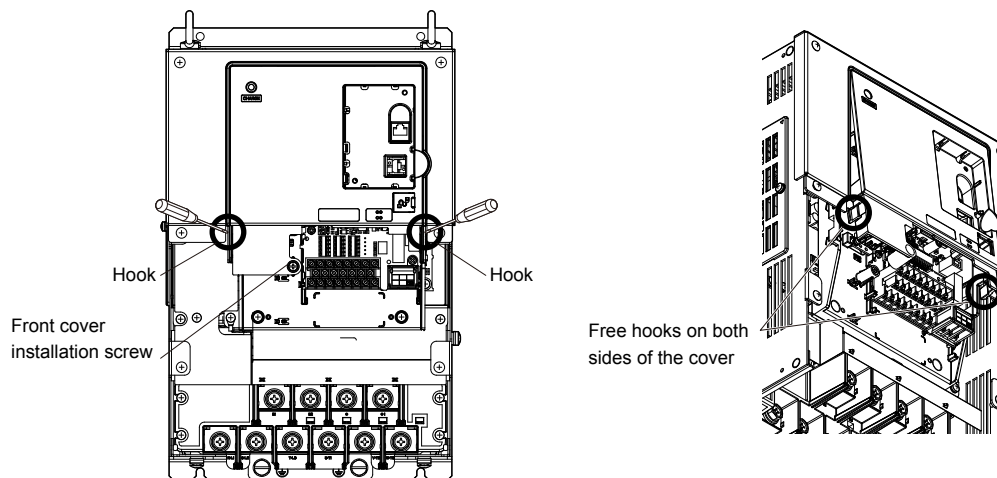

Figure 3.20 Remove the Front Cover (2A0010 to 2A0415 and 4A0058 to 4A1200)

4. Unhook the left side of the front cover then swing the left side towards you as shown in [Figure 3.21](#) until the cover comes off.

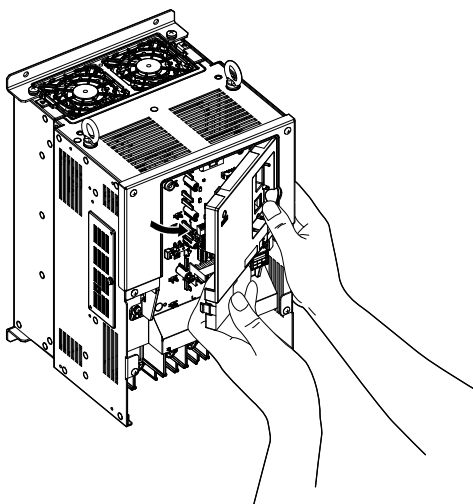

Figure 3.21 Remove the Front Cover (2A0010 to 2A0415 and 4A0058 to 4A1200)

■ Reattaching the Front Cover

Models 2A0004 to 2A0081, 4A0002 to 4A0044, and 5A0003 to 5A0032

Reverse the instructions given in *Remove the Front Cover (2A0004 to 2A0081, 4A0002 to 4A0044, and 5A0003 to 5A0032)* on page 83 to reattach the front cover. Pinch inwards on the hooks found on each side of the front cover while guiding it back into the drive. Make sure it clicks firmly into place.

Models 2A0110 to 2A0415 and 4A0058 to 4A1200

1. Slide the front cover so the hooks on the top connect to the drive.

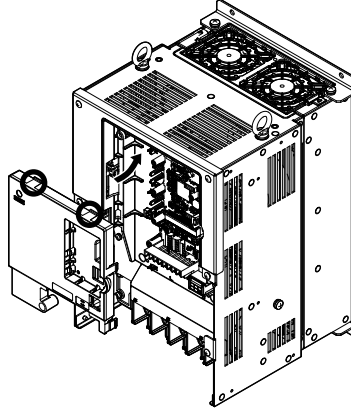

Figure 3.22 Reattach the Front Cover (2A0110 to 2A0415 and 4A0058 to 4A1200)

2. After connecting the hooks to the drive, press firmly on the cover to lock it into place.

3.7 Top Protective Cover

Drive models 2A0004 to 2A0081, 4A0002 to 4A0044, and 5A0003 to 5A0032 are designed to IP20/NEMA Type 1 specifications with a protective cover on the top. Removing this top protective cover or the bottom conduit bracket from an IP20/NEMA Type 1 enclosure drive voids the NEMA Type 1 protection while maintaining IP20 conformity.

◆ Removing the Top Protective Cover

Insert the tip of a straight-edge screwdriver into the small opening located on the front edge of the top protective cover. Gently apply pressure as shown in the figure below to free the cover from the drive.

Note: Removing the top protective cover or the bottom conduit bracket from an IP20/NEMA Type 1 enclosure drive voids the NEMA Type 1 protection while maintaining IP20 conformity.

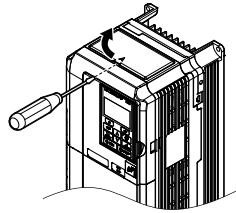

Figure 3.23 Removing the Top Protective Cover

◆ Reattaching the Top Protective Cover

Insert the two small protruding hooks on the rear side of the top protective cover into the provided mounting holes near the back of the drive, then press down on the front side of the top protective cover to fasten the cover into place.

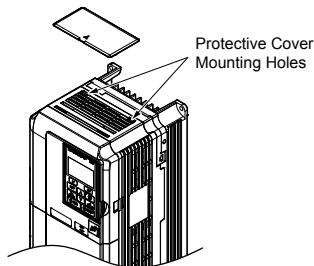

Figure 3.24 Reattaching the Protective Cover

3.8 Main Circuit Wiring

This section describes the functions, specifications, and procedures required to safely and properly wire the main circuit in the drive.

NOTICE: Do not solder the ends of wire connections to the drive. Soldered wiring connections can loosen over time. Improper wiring practices could result in drive malfunction due to loose terminal connections.

NOTICE: Do not switch the drive input to start or stop the motor. Frequently switching the drive on and off shortens the life of the DC bus charge circuit and the DC bus capacitors, and can cause premature drive failures. For the full performance life, refrain from switching the drive on and off more than once every 30 minutes.

Refer to [Input Fuse Installation on page 667](#) for details on fuse selection.

◆ Main Circuit Terminal Functions

Table 3.1 Main Circuit Terminal Functions

Terminal		Type				Function	Page
200 V Class	Drive Model	2A0004 to 2A0081	2A0110 to 2A0138	2A0169 to 2A0415	–		
400 V Class		4A0002 to 4A0044	4A0058, 4A0072	4A0088 to 4A0675	4A0930 to 4A1200		
600 V Class		5A0003 to 5A0032	5A0041 to 5A0052	5A0062 to 5A0242	–		
R/L1	Main circuit power supply input				Connects line power to the drive	73	
S/L2							
T/L3							
R1-L11	Not available				Main circuit power supply input	Connects line power to the drive Remove the shorting bars connecting R/L1-R1/L11, S/L2-S1/L21, T/L3-T1/L31 when using 12-phase rectification.	
S1-L21							
T1-L31							
U/T1	Drive output				Connects to the motor	73	
V/T2							
W/T3							
B1	Braking resistor		Not available		Available for connecting a braking resistor or a braking resistor unit option	449	
B2							
+2	<ul style="list-style-type: none"> DC link choke connection (+1, +2) (remove the shorting bar between +1 and +2) DC power supply input (+1, –) 	Not available				For connecting: <ul style="list-style-type: none"> the drive to a DC power supply (terminals +1 and – are not EÜ/CE or UL approved) dynamic braking options a DC link choke 	453
+1		DC power supply input (+1, –)		<ul style="list-style-type: none"> DC power supply input (+1, –) Braking unit connection (+3, –) 			
–							
+3	Not available						
⊕	For 200 V class: 100 Ω or less For 400 V class: 10 Ω or less For 600 V class: 10 Ω or less				Grounding terminal	96	

Note: Use terminals B1 and – when installing a CDBR-type braking unit on drives with built-in braking transistors (Models 2A0004 to 2A0138, 4A0002 to 4A0072, and 5A0003 to 5A0052).

3.8 Main Circuit Wiring

Wiring Fuses for Models 4A0930 and 4A1200

NOTICE: If a fuse is blown or an Ground Fault Circuit Interrupter (GFCI) is tripped, check the wiring and the selection of peripheral devices to identify the cause. Contact Yaskawa before restarting the drive or the peripheral devices if the cause cannot be identified.

Install a fuse on the input side to protect drive wiring and prevent other secondary damage. Wire the fuse so that leakage current in the upper controller power supply will trigger the fuse and shut off the power supply.

Select the appropriate fuse from [Table 3.2](#).

Table 3.2 Input Fuses for Models 4A0930 and 4A1200

Voltage Class	Model	Selection			Input Fuse (Example)			
		Input Voltage	Current	Pre-arc I^2t (A ² s)	Model	Manufacturer	Rating	Pre-arc I^2t (A ² s)
Three-Phase 400 V Class	4A0930	480 V	1500 A	140000 to 3100000	CS5F-1200	Fuji Electric	AC500 V, 1200 A	276000
					FWH-1200A	Bussman	AC500 V, 1200 A	–
	4A1200	480 V	1500 A	320000 to 3100000	CS5F-1500	Fuji Electric	AC500 V, 1500 A	351000
					FWH-1600A	Bussman	AC500 V, 1600 A	–

◆ Protecting Main Circuit Terminals

■ Insulation Caps or Sleeves

Use insulation caps or sleeves when wiring the drive with crimp terminals. Take particular care to ensure that the wiring does not touch nearby terminals or the surrounding case.

■ Insulation Barrier

Insulation barriers are packaged with drive models 4A0414 through 4A1200 to provide added protection between terminals. Yaskawa recommends using the provided insulation barriers to ensure proper wiring. Refer to [Figure 3.25](#) for instructions on placement of the insulation barriers.

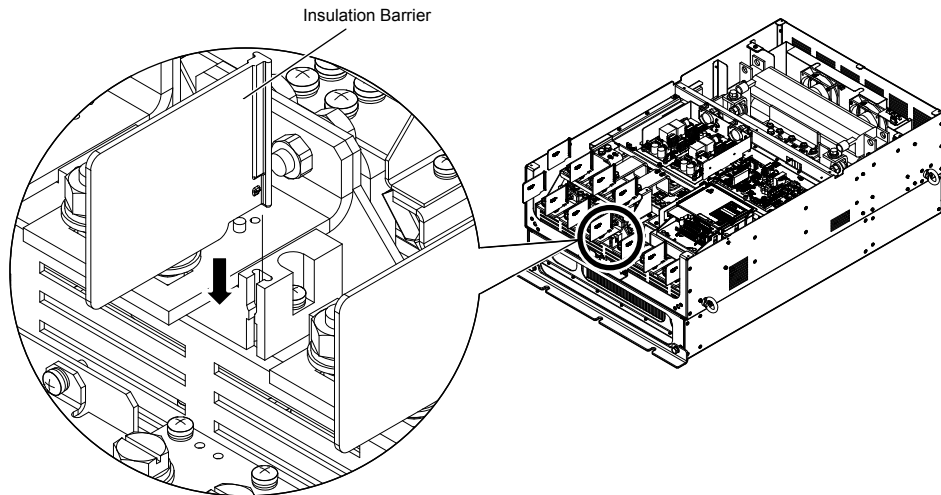

Figure 3.25 Installing Insulation Barriers

◆ Wire Gauges and Tightening Torque

Use the tables in this section to select the appropriate wires and crimp terminals.

Gauges listed in the tables are for use in the United States.

- Note:**
1. Wire gauge recommendations based on drive continuous current ratings (ND) using 75 °C 600 Vac vinyl-sheathed wire assuming ambient temperature within 40 °C and wiring distance less than 100 m.
 2. Terminals +1, +2, +3, –, B1 and B2 are for connecting optional devices such as a DC link choke or braking resistor. Do not connect other nonspecific devices to these terminals.

- Consider the amount of voltage drop when selecting wire gauges. Increase the wire gauge when the voltage drop is greater than 2% of motor rated voltage. Ensure the wire gauge is suitable for the terminal block. Use the following formula to calculate the amount of voltage drop:

$$\text{Line drop voltage (V)} = \sqrt{3} \times \text{wire resistance } (\Omega/\text{km}) \times \text{wire length (m)} \times \text{current (A)} \times 10^{-3}$$

- Refer to instruction manual TOBP C720600 00 for braking transistor option or braking resistor option wire gauges.
- Use terminals +1 and – when connecting a regenerative converter or a regen unit.

NOTICE: Do not connect a braking resistor to terminals +1 or –. Failure to comply may cause damage to the drive circuitry.

- Use terminals B1 and – when installing a CDBR-type braking unit on drives with built-in braking transistors (models 2A0004 to 2A0138, 4A0002 to 4A0072, and 5A0003 to 5A0052).

NOTICE: Do not connect a braking resistor to terminals +1 or –. Failure to comply may cause damage to the drive circuitry.

- **Refer to UL Standards Compliance on page 656** for information on UL compliance.

Yaskawa recommends using closed-loop crimp terminals on all drive models. UL/cUL approval requires the use of closed-loop crimp terminals when wiring the drive main circuit terminals on models 2A0110 to 2A0415 and 4A0058 to 4A1200. Use only the tools recommended by the terminal manufacturer for crimping. **Refer to Closed-Loop Crimp Terminal Size on page 663** for closed-loop crimp terminal recommendations.

The wire gauges listed in the following tables are Yaskawa recommendations. Refer to local codes for proper wire gauge selections.

■ Three-Phase 200 V Class

Table 3.3 Wire Gauge and Torque Specifications (Three-Phase 200 V Class)

Drive Model	Terminal	Recomm. Gauge AWG, kcmil	Wire Range AWG, kcmil	Screw Size	Tightening Torque N·m (lb.in.)
2A0004 2A0006 2A0008 2A0010	R/L1, S/L2, T/L3	14	14 to 10	M4	1.2 to 1.5 (10.6 to 13.3)
	U/T1, V/T2, W/T3	14	14 to 10		
	–, +1, +2	–	14 to 10		
	B1, B2	–	14 to 10		
	⊕	10 </>	14 to 10		
2A0012	R/L1, S/L2, T/L3	12	14 to 10	M4	1.2 to 1.5 (10.6 to 13.3)
	U/T1, V/T2, W/T3	14	14 to 10		
	–, +1, +2	–	14 to 10		
	B1, B2	–	14 to 10		
	⊕	10 </>	14 to 10		
2A0018	R/L1, S/L2, T/L3	10	12 to 10	M4	1.2 to 1.5 (10.6 to 13.3)
	U/T1, V/T2, W/T3	10	14 to 10		
	–, +1, +2	–	14 to 10		
	B1, B2	–	14 to 10		
	⊕	10 </>	14 to 10		
2A0021	R/L1, S/L2, T/L3	10	12 to 10	M4	1.2 to 1.5 (10.6 to 13.3)
	U/T1, V/T2, W/T3	10	12 to 10		
	–, +1, +2	–	12 to 10		
	B1, B2	–	14 to 10		
	⊕	10 </>	12 to 10		

3.8 Main Circuit Wiring

Drive Model	Terminal	Recomm. Gauge AWG, kcmil	Wire Range AWG, kcmil	Screw Size	Tightening Torque N·m (lb.in.)
2A0030	R/L1, S/L2, T/L3	8	10 to 6	M4	2.1 to 2.3 (18.4 to 20.4)
	U/T1, V/T2, W/T3	8	10 to 6		
	-, +1, +2	-	10 to 6		
	B1, B2	-	14 to 10		
	⊕	8 <?>	10 to 8	M5	2 to 2.5 (17.7 to 22.1)
2A0040	R/L1, S/L2, T/L3	6	8 to 6	M4	2.1 to 2.3 (18.4 to 20.4)
	U/T1, V/T2, W/T3	8	8 to 6		
	-, +1, +2	-	6		
	B1, B2	-	12 to 10		
	⊕	8 <?>	10 to 8	M5	2 to 2.5 (17.7 to 22.1)
2A0056	R/L1, S/L2, T/L3	4	6 to 4	M6	5.4 to 6.0 (47.8 to 53.1)
	U/T1, V/T2, W/T3	4	6 to 4		
	-, +1, +2	-	6 to 4		
	B1, B2	-	10 to 6	M5	2.7 to 3.0 (23.9 to 26.6)
	⊕	6	8 to 6	M6	4 to 6 (35.4 to 53.1)
2A0069	R/L1, S/L2, T/L3	3	4 to 3	M8	9.9 to 11.0 (87.6 to 97.4)
	U/T1, V/T2, W/T3	3	4 to 3		
	-, +1, +2	-	4 to 3		
	B1, B2	-	8 to 6	M5	2.7 to 3.0 (23.9 to 26.6)
	⊕	6	6 to 4	M6	4 to 6 (35.4 to 53.1)
2A0081	R/L1, S/L2, T/L3	2	3 to 2	M8	9.9 to 11.0 (87.6 to 97.4)
	U/T1, V/T2, W/T3	2	3 to 2		
	-, +1, +2	-	3 to 2		
	B1, B2	-	6	M5	2.7 to 3.0 (23.9 to 26.6)
	⊕	6	6 to 4	M6	4 to 6 (35.4 to 53.1)
2A0110 <?>	R/L1, S/L2, T/L3	1/0	3 to 1/0	M8	9 to 11 (79.7 to 97.4)
	U/T1, V/T2, W/T3	1/0	3 to 1/0		
	-, +1	-	2 to 1/0		
	B1, B2	-	6 to 1/0		
	⊕	6	6 to 4		
2A0138 <?>	R/L1, S/L2, T/L3	2/0	1 to 2/0	M10	18 to 23 (159 to 204)
	U/T1, V/T2, W/T3	2/0	1 to 2/0		
	-, +1	-	1/0 to 3/0		
	B1, B2	-	4 to 2/0		
	⊕	4	4	M8	9 to 11 (79.7 to 97.4)
2A0169 <?>	R/L1, S/L2, T/L3	4/0	2/0 to 4/0	M10	18 to 23 (159 to 204)
	U/T1, V/T2, W/T3	4/0	3/0 to 4/0		
	-, +1	-	1 to 4/0		
	+3	-	1/0 to 4/0		
	⊕	4	4 to 2		
2A0211 <?>	R/L1, S/L2, T/L3	1/0 × 2P	1/0 to 2/0	M10	18 to 23 (159 to 204)
	U/T1, V/T2, W/T3	1/0 × 2P	1/0 to 2/0		
	-, +1	-	1 to 4/0		
	+3	-	1/0 to 4/0		
	⊕	4	4 to 1/0		

Drive Model	Terminal	Recomm. Gauge AWG, kcmil	Wire Range AWG, kcmil	Screw Size	Tightening Torque N·m (lb.in.)
2A0250 <2>	R/L1, S/L2, T/L3	3/0 × 2P	3/0 to 300	M12	32 to 40 (283 to 354)
	U/T1, V/T2, W/T3	3/0 × 2P	3/0 to 300		
	-, +1	-	3/0 to 300		
	+3	-	2 to 300	M10	18 to 23 (159 to 204)
	⊕	3	3 to 300	M12	32 to 40 (283 to 354)
2A0312 <2>	R/L1, S/L2, T/L3	4/0 × 2P	3/0 to 300	M12	32 to 40 (283 to 354)
	U/T1, V/T2, W/T3	3/0 × 2P	3/0 to 300		
	-, +1	-	3/0 to 300		
	+3	-	3/0 to 300	M10	18 to 23 (159 to 204)
	⊕	2	2 to 300	M12	32 to 40 (283 to 354)
2A0360 <2>	R/L1, S/L2, T/L3	250 × 2P	4/0 to 600	M12	32 to 40 (283 to 354)
	U/T1, V/T2, W/T3	4/0 × 2P	4/0 to 600		
	-, +1	-	250 to 600		
	+3	-	3/0 to 600	M10	18 to 23 (159 to 204)
	⊕	1	1 to 350	M12	32 to 40 (283 to 354)
2A0415 <2>	R/L1, S/L2, T/L3	350 × 2P	250 to 600	M12	32 to 40 (283 to 354)
	U/T1, V/T2, W/T3	300 × 2P	300 to 600		
	-, +1	-	300 to 600		
	+3	-	3/0 to 600	M10	18 to 23 (159 to 204)
	⊕	1	1 to 350	M12	32 to 40 (283 to 354)

- <1> When installing an EMC filter, additional measures must be taken to comply with IEC61800-5-1. *Refer to EMC Filter Installation on page 650* for details.
- <2> Drive models 2A0110 to 2A0415 require the use of UL-Listed closed-loop crimp terminals for UL/cUL compliance. Use only the tools recommended by the terminal manufacturer for crimping.

■ Three-Phase 400 V Class

Table 3.4 Wire Gauge and Torque Specifications (Three-Phase 400 V Class)

Drive Model	Terminal	Recomm. Gauge AWG, kcmil	Wire Range AWG, kcmil	Screw Size	Tightening Torque N·m (lb.in.)
4A0002 4A0004	R/L1, S/L2, T/L3	14	14 to 10	M4	1.2 to 1.5 (10.6 to 13.3)
	U/T1, V/T2, W/T3	14	14 to 10		
	-, +1, +2	-	14 to 10		
	B1, B2	-	14 to 10		
	⊕	12	14 to 12		
4A0005 4A0007 4A0009	R/L1, S/L2, T/L3	14	14 to 10	M4	1.2 to 1.5 (10.6 to 13.3)
	U/T1, V/T2, W/T3	14	14 to 10		
	-, +1, +2	-	14 to 10		
	B1, B2	-	14 to 10		
	⊕	10	14 to 10		
4A0011	R/L1, S/L2, T/L3	12	14 to 10	M4	1.2 to 1.5 (10.6 to 13.3)
	U/T1, V/T2, W/T3	14	14 to 10		
	-, +1, +2	-	14 to 10		
	B1, B2	-	14 to 10		
	⊕	10	14 to 10		

3.8 Main Circuit Wiring

Drive Model	Terminal	Recomm. Gauge AWG, kcmil	Wire Range AWG, kcmil	Screw Size	Tightening Torque N·m (lb.in.)
4A0018	R/L1, S/L2, T/L3	10	12 to 6	M4	2.1 to 2.3 (18.4 to 20.4)
	U/T1, V/T2, W/T3	10	12 to 6		
	-, +1, +2	-	12 to 6		
	B1, B2	-	12 to 10		
	⊕	10	14 to 10	M5	2 to 2.5 (17.7 to 22.1)
4A0023	R/L1, S/L2, T/L3	10	10 to 6	M4	2.1 to 2.3 (18.4 to 20.4)
	U/T1, V/T2, W/T3	10	10 to 6		
	-, +1, +2	-	12 to 6		
	B1, B2	-	12 to 10		
	⊕	10	12 to 10	M5	2 to 2.5 (17.7 to 22.1)
4A0031	R/L1, S/L2, T/L3	8	8 to 6	M5	2.7 to 3.0 (23.9 to 26.6)
	U/T1, V/T2, W/T3	8	10 to 6		
	-, +1, +2	-	10 to 6		
	B1, B2	-	10 to 8	M5	4 to 6 (35.4 to 53.1)
	⊕	8	10 to 8	M6	
4A0038	R/L1, S/L2, T/L3	6	8 to 6	M5	2.7 to 3.0 (23.9 to 26.6)
	U/T1, V/T2, W/T3	8	8 to 6		
	-, +1, +2	-	6		
	B1, B2	-	10 to 8	M5	4 to 6 (35.4 to 53.1)
	⊕	6	10 to 6	M6	
4A0044	R/L1, S/L2, T/L3	6	6 to 4	M6	5.4 to 6.0 (47.8 to 53.1)
	U/T1, V/T2, W/T3	6	6 to 4		
	-, +1, +2	-	6 to 4		
	B1, B2	-	10 to 8	M5	2.7 to 3.0 (23.9 to 26.6)
	⊕	6	8 to 6	M6	4 to 6 (35.4 to 53.1)
4A0058 <>	R/L1, S/L2, T/L3	4	6 to 4	M8	9 to 11 (79.7 to 97.4)
	U/T1, V/T2, W/T3	4	6 to 4		
	-, +1	-	6 to 1		
	B1, B2	-	8 to 4		
	⊕	6	8 to 6		
4A0072 <>	R/L1, S/L2, T/L3	3	4 to 3	M8	9 to 11 (79.7 to 97.4)
	U/T1, V/T2, W/T3	3	4 to 3		
	-, +1	-	4 to 1		
	B1, B2	-	6 to 3		
	⊕	6	6		
4A0088 <>	R/L1, S/L2, T/L3	2	3 to 1/0	M8	9 to 11 (79.7 to 97.4)
	U/T1, V/T2, W/T3	2	3 to 1/0		
	-, +1	-	3 to 1/0		
	+3	-	6 to 1/0		
	⊕	4	6 to 4		
4A0103 <>	R/L1, S/L2, T/L3	1/0	2 to 1/0	M8	9 to 11 (79.7 to 97.4)
	U/T1, V/T2, W/T3	1	2 to 1/0		
	-, +1	-	3 to 1/0		
	+3	-	4 to 1/0		
	⊕	4	6 to 4		

Drive Model	Terminal	Recomm. Gauge AWG, kcmil	Wire Range AWG, kcmil	Screw Size	Tightening Torque N·m (lb.in.)
4A0139 </>	R/L1, S/L2, T/L3	3/0	1/0 to 4/0	M10	18 to 23 (159 to 204)
	U/T1, V/T2, W/T3	2/0	1/0 to 4/0		
	-, +1	-	1/0 to 4/0		
	+3	-	3 to 4/0		
	⊕	4	4		
4A0165 </>	R/L1, S/L2, T/L3	4/0	3/0 to 4/0	M10	18 to 23 (159 to 204)
	U/T1, V/T2, W/T3	4/0	3/0 to 4/0		
	-,+1	-	1 to 4/0		
	+3	-	1/0 to 4/0		
	⊕	4	4 to 2		
4A0208 </>	R/L1, S/L2, T/L3	300	2 to 300	M10	18 to 23 (159 to 204)
	U/T1, V/T2, W/T3	300	2 to 300		
	-,+1	-	1 to 250		
	+3	-	3 to 3/0		
	⊕	4	4 to 300		
4A0250 </>	R/L1, S/L2, T/L3	400	1 to 600	M10	18 to 23 (159 to 204)
	U/T1, V/T2, W/T3	400	1/0 to 600		
	-,+1	-	3/0 to 600		
	+3	-	1 to 325		
	⊕	2	2 to 350		
4A0296 </>	R/L1, S/L2, T/L3	500	2/0 to 600	M12	32 to 40 (283 to 354)
	U/T1, V/T2, W/T3	500	2/0 to 600		
	-,+1	-	3/0 to 600	M10	18 to 23 (159 to 204)
	+3	-	1 to 325		
	⊕	2	2 to 350		
4A0362 </>	R/L1, S/L2, T/L3	4/0 × 2P	3/0 to 600	M12	32 to 40 (283 to 354)
	U/T1, V/T2, W/T3	4/0 × 2P	3/0 to 600		
	-,+1	-	4/0 to 600	M10	18 to 23 (159 to 204)
	+3	-	3/0 to 600		
	⊕	1	1 to 350		
4A0414 </> </>	R/L1, S/L2, T/L3	300 × 2P	4/0 to 300	M12	32 to 40 (283 to 354)
	U/T1, V/T2, W/T3	300 × 2P	4/0 to 300		
	-,+1	-	3/0 to 300		
	+3	-	3/0 to 300		
	⊕	1	1 to 3/0		
4A0515 </> </>	R/L1, S/L2, T/L3	3/0 × 4P	3/0 to 300	M12	32 to 40 (283 to 354)
	U/T1, V/T2, W/T3	4/0 × 4P	3/0 to 300		
	-,+1	-	1/0 to 300		
	+3	-	1/0 to 300		
	⊕	1/0	1/0 to 300		
4A0675 </> </>	R/L1, S/L2, T/L3	300 × 4P	4/0 to 300	M12	32 to 40 (283 to 354)
	U/T1, V/T2, W/T3	300 × 4P	4/0 to 300		
	-,+1	-	1/0 to 300		
	+3	-	1/0 to 300		
	⊕	2/0	2/0 to 300		

3.8 Main Circuit Wiring

Drive Model	Terminal	Recomm. Gauge AWG, kcmil	Wire Range AWG, kcmil	Screw Size	Tightening Torque N·m (lb.in.)
4A0930 <1> <2>	R/L1, S/L2, T/L3, R1/L11, S1/L21, T1/L31	4/0 × 4P×2	3/0 to 300	M12	32 to 40 (283 to 354)
	U/T1, V/T2, W/T3	4/0 × 4P×2	3/0 to 300		
	-, +1	-	4/0 to 300		
	+3	-	4/0 to 300		
	⊕	3/0	3/0 to 250		
4A1200 <1> <2>	R/L1, S/L2, T/L3, R1/L11, S1/L21, T1/L31	300 × 4P×2	4/0 to 300	M12	32 to 40 (283 to 354)
	U/T1, V/T2, W/T3	300 × 4P×2	4/0 to 300		
	-, +1	-	250 to 300		
	+3	-	4/0 to 300		
	⊕	4/0	4/0 to 250		

<1> Drive models 4A0058 to 4A1200 require the use of UL-Listed closed-loop crimp terminals for UL/cUL compliance. Use only the tools recommended by the terminal manufacturer for crimping.

<2> When installing an EMC filter, additional measures must be taken to comply with IEC61800-5-1. [Refer to EMC Filter Installation on page 650](#) for details.

■ Three-Phase 600 V Class

Table 3.5 Wire Gauge and Torque Specifications (Three-Phase 600 V Class)

Drive Model	Terminal	Recomm. Gauge AWG, kcmil	Wire Range AWG, kcmil	Screw Size	Tightening Torque N·m (lb.in.)
5A0003 5A0004 5A0006	R/L1, S/L2, T/L3	14	14 to 10	M4	1.2 to 1.5 (10.6 to 13.3)
	U/T1, V/T2, W/T3	14	14 to 10		
	-, +1, +2	-	14 to 10		
	B1, B2	-	14 to 10		
	⊕	10	14 to 10		
5A0009	R/L1, S/L2, T/L3	14	14 to 10	M4	1.2 to 1.5 (10.6 to 13.3)
	U/T1, V/T2, W/T3	14	14 to 10		
	-, +1, +2	-	14 to 10		
	B1, B2	-	14 to 10		
	⊕	10	12 to 10		
5A0011	R/L1, S/L2, T/L3	10	14 to 6	M4	1.2 to 1.5 (10.6 to 13.3)
	U/T1, V/T2, W/T3	14	14 to 6		
	-, +1, +2	-	14 to 6		
	B1, B2	-	14 to 10		
	⊕	8	12 to 8	M5	2 to 2.5 (17.7 to 22.1)
5A0017	R/L1, S/L2, T/L3	10	10 to 6	M5	2 to 2.5 (17.7 to 22.1)
	U/T1, V/T2, W/T3	10	10 to 6		
	-, +1, +2	-	10 to 6		
	B1, B2	-	10 to 8		
	⊕	8	12 to 8	M6	4 to 6 (35.4 to 53.1)
5A0022	R/L1, S/L2, T/L3	8	10 to 6	M5	2 to 2.5 (17.7 to 22.1)
	U/T1, V/T2, W/T3	10	10 to 6		
	-, +1, +2	-	10 to 6		
	B1, B2	-	10 to 8		
	⊕	8	10 to 6	M6	4 to 6 (35.4 to 53.1)

Drive Model	Terminal	Recomm. Gauge AWG, kcmil	Wire Range AWG, kcmil	Screw Size	Tightening Torque N·m (lb.in.)
5A0027 5A0032	R/L1, S/L2, T/L3	6	6 to 4	M6	4 to 6 (35.4 to 53.1)
	U/T1, V/T2, W/T3	6	6 to 4		
	-, +1, +2	-	6 to 4		
	B1, B2	-	10 to 8	M5	2 to 2.5 (17.7 to 22.1)
	⊕	6	10 to 6	M6	4 to 6 (35.4 to 53.1)
5A0041	R/L1, S/L2, T/L3	6	10 to 3	M8	9 to 11 (79.7 to 97.4)
	U/T1, V/T2, W/T3	6	10 to 3		
	-, +1	-	6 to 1		
	B1, B2	-	12 to 3		
	⊕	6	6		
5A0052	R/L1, S/L2, T/L3	4	10 to 3	M8	9 to 11 (79.7 to 97.4)
	U/T1, V/T2, W/T3	6	10 to 3		
	-, +1	-	6 to 1		
	B1, B2	-	8 to 3		
	⊕	6	6		
5A0062	R/L1, S/L2, T/L3	4	10 to 4/0	M10	18 to 23 (159 to 204)
	U/T1, V/T2, W/T3	4	10 to 4/0		
	-, +1	-	4 to 4/0		
	+3	-	6 to 4/0		
	⊕	4	4		
5A0077	R/L1, S/L2, T/L3	3	10 to 4/0	M10	18 to 23 (159 to 204)
	U/T1, V/T2, W/T3	3	10 to 4/0		
	-, +1	-	3 to 4/0		
	+3	-	6 to 4/0		
	⊕	4	4		
5A0099	R/L1, S/L2, T/L3	1/0	10 to 4/0	M10	18 to 23 (159 to 204)
	U/T1, V/T2, W/T3	1	10 to 4/0		
	-, +1	-	2 to 4/0		
	+3	-	4 to 4/0		
	⊕	4	4		
5A0125	R/L1, S/L2, T/L3	2/0	1 to 300	M10	18 to 23 (159 to 204)
	U/T1, V/T2, W/T3	2/0	1 to 300		
	-, +1	-	2/0 to 3/0		
	+3	-	1 to 1/0		
	⊕	3	4 to 300		
5A0145	R/L1, S/L2, T/L3	3/0	2/0 to 300	M10	18 to 23 (159 to 204)
	U/T1, V/T2, W/T3	3/0	2/0 to 300		
	-, +1	-	3/0 to 4/0		
	+3	-	1/0 to 2/0		
	⊕	3	4 to 300		
5A0192	R/L1, S/L2, T/L3	300	2/0 to 600	M12	32 to 40 (283 to 354)
	U/T1, V/T2, W/T3	250	2/0 to 600		
	-, +1	-	2/0 to 400	M10	18 to 23 (159 to 204)
	+3	-	2/0 to 250		
	⊕	1	1 to 350		

3.8 Main Circuit Wiring

Drive Model	Terminal	Recomm. Gauge AWG, kcmil	Wire Range AWG, kcmil	Screw Size	Tightening Torque N·m (lb.in.)
5A0242	R/L1, S/L2, T/L3	400	2/0 to 600	M12	32 to 40 (283 to 354)
	U/T1, V/T2, W/T3	350	2/0 to 600		
	-, +1	–	2/0 to 500		
	+3	–	250 to 300	M10	18 to 23 (159 to 204)
	⊕	1	1 to 350	M12	32 to 40 (283 to 354)

◆ Main Circuit Terminal and Motor Wiring

This section outlines the various steps, precautions, and checkpoints for wiring the main circuit terminals and motor terminals.

WARNING! Electrical Shock Hazard. Do not connect the AC power line to the output terminals of the drive. Failure to comply could result in death or serious injury by fire as a result of drive damage from line voltage application to output terminals.

NOTICE: When connecting the motor to the drive output terminals U/T1, V/T2, and W/T3, the phase order for the drive and motor should match. Failure to comply with proper wiring practices may cause the motor to run in reverse if the phase order is backward.

NOTICE: Do not connect phase-advancing capacitors or LC/RC noise filters to the output circuits. Failure to comply could result in damage to the drive, phase-advancing capacitors, LC/RC noise filters or ground fault circuit interrupters.

■ Cable Length Between Drive and Motor

Voltage drop along the motor cable may cause reduced motor torque when the wiring between the drive and the motor is too long, especially at low frequency output. This can also be a problem when motors are connected in parallel with a fairly long motor cable. Drive output current will increase as the leakage current from the cable increases. An increase in leakage current may trigger an overcurrent situation and weaken the accuracy of the current detection.

Adjust the drive carrier frequency according to [Table 3.6](#). If the motor wiring distance exceeds 100 m because of the system configuration, reduce the ground currents. [Refer to C6-02: Carrier Frequency Selection on page 206.](#)

Table 3.6 Cable Length Between Drive and Motor

Cable Length	50 m or less	100 m or less	Greater than 100 m
Carrier Frequency	15 kHz or less	5 kHz or less	2 kHz or less

- Note:**
1. When setting carrier frequency for drives running multiple motors, calculate cable length as the total wiring distance to all connected motors.
 2. The maximum cable length when using OLV/PM (A1-02 = 5) or AOLV/PM (A1-02 = 6) is 100 m.

■ Ground Wiring

Follow the precautions below when wiring the ground for one drive or a series of drives.

WARNING! Electrical Shock Hazard. Make sure the protective earthing conductor complies with technical standards and local safety regulations. Because the leakage current exceeds 3.5 mA in models 4A0414 and larger, IEC 61800-5-1 states that either the power supply must be automatically disconnected in case of discontinuity of the protective earthing conductor or a protective earthing conductor with a cross-section of at least 10 mm² (Cu) or 16 mm² (Al) must be used. Failure to comply may result in death or serious injury.

WARNING! Electrical Shock Hazard. Always use a ground wire that complies with technical standards on electrical equipment and minimize the length of the ground wire. Improper equipment grounding may cause dangerous electrical potentials on equipment chassis, which could result in death or serious injury.

WARNING! Electrical Shock Hazard. Be sure to ground the drive ground terminal (200 V class: ground to 100 Ω or less; 400 V class: ground to 10 Ω or less; 600 V class: ground to 10 Ω or less). Improper equipment grounding could result in death or serious injury by contacting ungrounded electrical equipment.

NOTICE: Do not share the ground wire with other devices such as welding machines or large-current electrical equipment. Improper equipment grounding could result in drive or equipment malfunction due to electrical interference.

NOTICE: When using more than one drive, ground multiple drives according to instructions. Improper equipment grounding could result in abnormal operation of drive or equipment.

Refer to [Figure 3.26](#) when using multiple drives. Do not loop the ground wire.

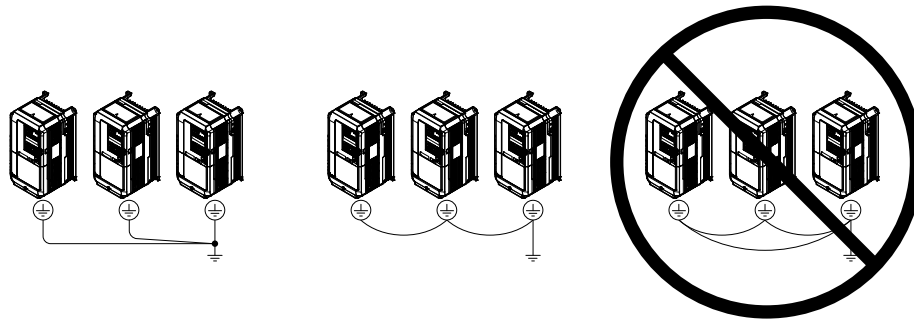

Figure 3.26 Multiple Drive Wiring

■ Wiring the Main Circuit Terminal

WARNING! *Electrical Shock Hazard. Shut off the power supply to the drive before wiring the main circuit terminals. Failure to comply may result in death or serious injury.*

Wire the main circuit terminals after the terminal board has been properly grounded.

Models 2A0004 to 2A0081, 4A0002 to 4A0044, and 5A0003 to 5A0032 have a cover placed over the DC bus and braking circuit terminals prior to shipment to help prevent miswiring. Use wire cutters to cut away covers as needed for terminals.

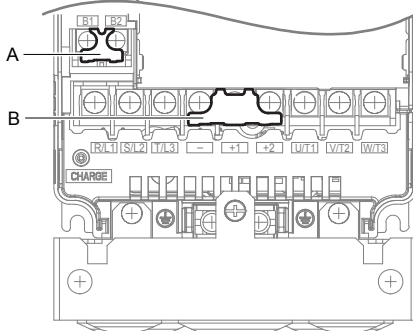

A – Braking circuit protective cover B – DC bus protective cover

Figure 3.27 Protecting Cover to Prevent Miswiring (Model 5A0011)

■ Main Circuit Connection Diagram

Refer to Main Circuit Connection Diagram on page 75 when wiring terminals on the main power circuit of the drive.

WARNING! *Fire Hazard. The braking resistor connection terminals are B1 and B2. Do not connect braking resistors to any other terminals. Improper wiring connections could cause the braking resistor to overheat and cause death or serious injury by fire. Failure to comply may result in damage to the braking circuit or drive.*

3.9 Control Circuit Wiring

◆ Control Circuit Connection Diagram

Refer to [Figure 3.1](#) on page 73 when wiring terminals on the drive control circuit.

◆ Control Circuit Terminal Block Functions

Drive parameters determine which functions apply to the multi-function digital inputs (S1 to S8), multi-function digital outputs (M1 to M6), multi-function analog inputs (A1 to A3), and multi-function analog monitor output (FM, AM). The default setting is listed next to each terminal in [Figure 3.1](#) on page 73.

WARNING! *Sudden Movement Hazard. Always check the operation and wiring of control circuits after being wired. Operating a drive with untested control circuits could result in death or serious injury.*

WARNING! *Sudden Movement Hazard. Confirm the drive I/O signals and external sequence before starting test run. Setting parameter A1-06 may change the I/O terminal function automatically from the factory setting. Refer to [Application Selection on page 132](#). Failure to comply may result in death or serious injury.*

■ Input Terminals

[Table 3.7](#) lists the input terminals on the drive. Text in parenthesis indicates the default setting for each multi-function input.

Table 3.7 Control Circuit Input Terminals

Type	No.	Terminal Name (Function)	Function (Signal Level) Default Setting	Page	
Multi-Function Digital Inputs	S1	Multi-function input 1 (Closed: Forward run, Open: Stop)	<ul style="list-style-type: none"> • Photocoupler • 24 Vdc, 8 mA • Set the S3 jumper to select between sinking, sourcing mode, and the power supply. Refer to Sinking/Sourcing Mode Switch for Digital Inputs on page 104. 	247	
	S2	Multi-function input 2 (Closed: Reverse run, Open: Stop)			
	S3	Multi-function input 3 (External fault, N.O.)			
	S4	Multi-function input 4 (Fault reset)			
	S5	Multi-function input 5 (Multi-step speed reference 1)			
	S6	Multi-function input 6 (Multi-step speed reference 2)			
	S7	Multi-function input 7 (Jog reference)			
	S8	Multi-function input 8 (Baseblock command (N.O.))			
	SC	Multi-function input common			Multi-function input common
	SP	Digital input power supply +24 Vdc			24 Vdc power supply for digital inputs, 150 mA max (only when not using digital input option DI-A3)
SN	Digital input power supply 0 V	NOTICE: Do not jumper or short terminals SP and SN. Failure to comply will damage the drive.	104		
Safe Disable Inputs	H1	Safe Disable input 1 </>	<ul style="list-style-type: none"> • 24 Vdc, 8 mA • One or both open: Output disabled • Both closed: Normal operation • Internal impedance: 3.3 kΩ • Off time of at least 1 ms • Disconnect the wire jumpers shorting terminals H1, H2, and HC to use the Safe Disable inputs. Set the S5 jumper to select between sinking, sourcing mode, and the power supply as explained on page 104. 	675	
	H2	Safe Disable input 2 </>			
	HC	Safe Disable function common			Safe disable function common

Type	No.	Terminal Name (Function)	Function (Signal Level) Default Setting	Page
Analog Inputs / Pulse Train Input	RP	Multi-function pulse train input (Frequency reference)	<ul style="list-style-type: none"> Input frequency range: 0 to 32 kHz Signal Duty Cycle: 30 to 70% High level: 3.5 to 13.2 Vdc, low level: 0.0 to 0.8 Vdc Input impedance: 3 kΩ 	163 276
	+V	Power supply for analog inputs	10.5 Vdc (max allowable current 20 mA)	162
	-V	Power supply for analog inputs	-10.5 Vdc (max allowable current 20 mA)	–
	A1	Multi-function analog input 1 (Frequency reference bias)	-10 to 10 Vdc, 0 to 10 Vdc (input impedance: 20 kΩ)	162 268
	A2	Multi-function analog input 2 (Frequency reference bias)	<ul style="list-style-type: none"> -10 to 10 Vdc, 0 to 10 Vdc (input impedance: 20 kΩ) 4 to 20 mA, 0 to 20 mA (input impedance: 250 Ω) Voltage or current input must be selected by DIP switch S1 and H3-09. 	162 162 270
	A3	Multi-function analog input 3 (Auxiliary frequency reference)/PTC Input	<ul style="list-style-type: none"> -10 to 10 Vdc, 0 to 10 Vdc (input impedance: 20 kΩ) Use DIP switch S4 on the terminal board to select between analog and PTC input. 	162
	AC	Frequency reference common	0 V	162
E (G)	Ground for shielded lines and option cards	–	–	

<1> Terminals H1, H2, DM+, and DM- on 600 V class models are designed to the functionality, but are not certified to EN61800-5-1, ISO13849 Cat. 3, IEC/EN61508 SIL2, Insulation coordination: class 1.

■ Output Terminals

[Table 3.8](#) lists the output terminals on the drive. Text in parenthesis indicates the default setting for each multi-function output.

Table 3.8 Control Circuit Output Terminals

Type	No.	Terminal Name (Function)	Function (Signal Level) Default Setting	Page
Fault Relay Output	MA	N.O.	30 Vdc, 10 mA to 1 A; 250 Vac, 10 mA to 1 A Minimum load: 5 Vdc, 10 mA	258
	MB	N.C. output		
	MC	Fault output common		
Multi-Function Digital Output <1>	M1	Multi-function digital output (During run)	30 Vdc, 10 mA to 1 A; 250 Vac, 10 mA to 1 A Minimum load: 5 Vdc, 10 mA	258
	M2			
	M3	Multi-function digital output (Zero speed)		
	M4			
	M5	Multi-function digital output (Speed Agree 1)		
M6				
Monitor Output	MP	Pulse train output (Output frequency)	32 kHz (max)	276
	FM	Analog monitor output 1 (Output frequency)	-10 to +10 Vdc, or 0 to +10 Vdc	274
	AM	Analog monitor output 2 (Output current)		
	AC	Monitor common	0 V	–
Safety Monitor Output <2>	DM+	Safety monitor output	Outputs status of Safe Disable function. Closed when both Safe Disable channels are closed. Up to +48 Vdc 50 mA	677
	DM-	Safety monitor output common		

<1> Refrain from assigning functions to digital relay outputs that involve frequent switching, as doing so may shorten relay performance life. Switching life is estimated at 200,000 times (assumes 1 A, resistive load).

<2> Terminals H1, H2, DM+, and DM- on 600 V class models are designed to the functionality, but are not certified to EN61800-5-1, ISO13849 Cat. 3, IEC/EN61508 SIL2, Insulation coordination: class 1.

Connect a suppression diode as shown in [Figure 3.28](#) when driving a reactive load such as a relay coil. Ensure the diode rating is greater than the circuit voltage.

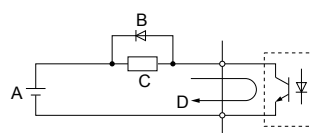

A – External power, 48 V max.
B – Suppression diode

C – Coil
D – 50 mA or less

Figure 3.28 Connecting a Suppression Diode

3.9 Control Circuit Wiring

Serial Communication Terminals

Table 3.9 Control Circuit Terminals: Serial Communications

Type	No.	Signal Name	Function (Signal Level)	
MEMOBUS/Modbus Communication <1>	R+	Communications input (+)	MEMOBUS/Modbus communication: Use an RS-422 or RS-485 cable to connect the drive.	RS-422/RS-485 MEMOBUS/Modbus communication protocol 115.2 kbps (max.)
	R-	Communications input (-)		
	S+	Communications output (+)		
	S-	Communications output (-)		
	IG	Shield ground	0 V	

<1> Enable the termination resistor in the last drive in a MEMOBUS/Modbus network by setting DIP switch S2 to the ON position. Refer to Control I/O Connections on page 104 for more information on the termination resistor.

Terminal Configuration

The control circuit terminals are arranged as shown in Figure 3.29.

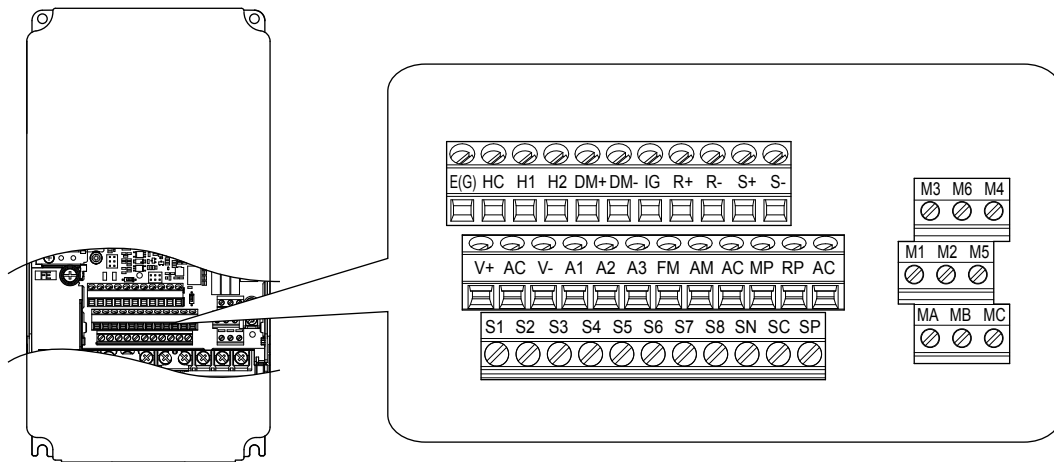

Figure 3.29 Control Circuit Terminal Arrangement

Wire Size and Torque Specifications

Select appropriate wire type and gauges from Table 3.10. For simpler and more reliable wiring, use crimp ferrules on the wire ends. Refer to Table 3.11 for ferrule terminal types and sizes.

Table 3.10 Wire Gauges

Terminal	Screw Size	Tightening Torque N·m (lb. in)	Bare Wire Terminal		Ferrule-Type Terminal		Wire Type
			Applicable wire size mm ² (AWG)	Recomm. wire size mm ² (AWG)	Applicable wire size mm ² (AWG)	Recomm. wire size mm ² (AWG)	
S1-S8, SC, SN, SP	M3	0.5 to 0.6 (4.4 to 5.3)	Stranded wire: 0.2 to 1.0 (24 to 16) Solid wire: 0.2 to 1.5 (24 to 16)	0.75 (18)	0.25 to 0.5 (24 to 20)	0.5 (20)	Shielded wire, etc.
H1, H2, HC							
RP, V+, V-, A1, A2, A3, AC							
MA, MB, MC							
M1-M6							
MP, FM, AM, AC							
DM+, DM-							
R+, R-, S+, S-, IG							

■ Ferrule-Type Wire Terminals

Yaskawa recommends using CRIMPFOX 6, a crimping tool manufactured by PHOENIX CONTACT, to prepare wire ends with insulated sleeves before connecting to the drive. See [Table 3.11](#) for dimensions.

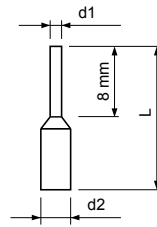

Figure 3.30 Ferrule Dimensions

Table 3.11 Ferrule Terminal Types and Sizes

Size mm ² (AWG)	Type	L (mm)	d1 (mm)	d2 (mm)	Manufacturer
0.25 (24)	AI 0.25-8YE	12.5	0.8	1.8	PHOENIX CONTACT
0.34 (22)	AI 0.34-8TQ	10.5	0.8	1.8	
0.5 (20)	AI 0.5-8WH or AI 0.5-8OG	14	1.1	2.5	

◆ Wiring the Control Circuit Terminal

This section describes the proper procedures and preparations for wiring the control terminals.

WARNING! *Electrical Shock Hazard. Do not remove covers or touch the circuit boards while the power is on. Failure to comply could result in death or serious injury.*

NOTICE: *Separate control circuit wiring from main circuit wiring (terminals R/L1, S/L2, T/L3, B1, B2, U/T1, V/T2, W/T3, -, +1, +2) and other high-power lines. Improper wiring practices could result in drive malfunction due to electrical interference.*

NOTICE: *Separate wiring for digital output terminals MA, MB, MC, and M1 to M6 from wiring to other control circuit lines. Improper wiring practices could result in drive or equipment malfunction or nuisance trips.*

NOTICE: *Use a class 2 power supply when connecting to the control terminals. Improper application of peripheral devices could result in drive performance degradation due to improper power supply. Refer to NEC Article 725 Class 1, Class 2, and Class 3 Remote-Control, Signaling, and Power Limited Circuits for requirements concerning class 2 power supplies.*

NOTICE: *Insulate shields with tape or shrink tubing to prevent contact with other signal lines and equipment. Improper wiring practices could result in drive or equipment malfunction due to short circuit.*

NOTICE: *Connect the shield of shielded cable to the appropriate ground terminal. Improper equipment grounding could result in drive or equipment malfunction or nuisance trips.*

Wire the control circuit only after terminals have been properly grounded and main circuit wiring is complete. [Refer to Terminal Board Wiring Guide on page 102](#) for details. Prepare the ends of the control circuit wiring as shown in [Figure 3.33](#). [Refer to Wire Gauges on page 100](#).

NOTICE: *Do not tighten screws beyond the specified tightening torque. Failure to comply may result in erroneous operation, damage to the terminal block, or cause a fire.*

NOTICE: *Use shielded twisted-pair cables as indicated to prevent operating faults. Improper wiring practices could result in drive or equipment malfunction due to electrical interference.*

Connect control wires as shown in [Figure 3.31](#) and [Figure 3.32](#).

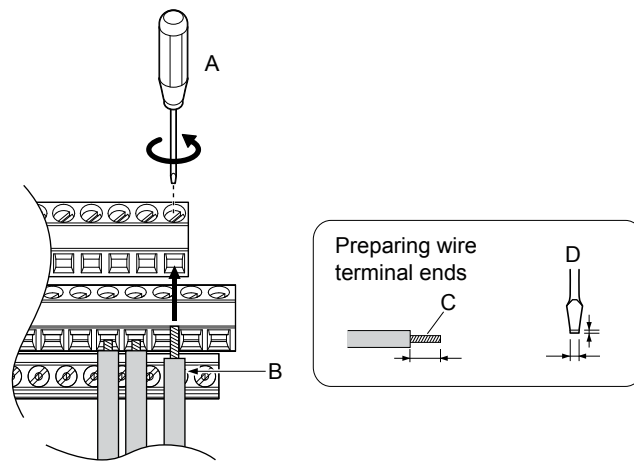

A – Loosen screw to insert wire.
B – Single wire or stranded wire

C – Avoid fraying wire strands when stripping insulation from wire. Strip length 5.5 mm.

D – Blade depth of 0.4 mm or less
 Blade width of 2.5 mm or less

Figure 3.31 Terminal Board Wiring Guide

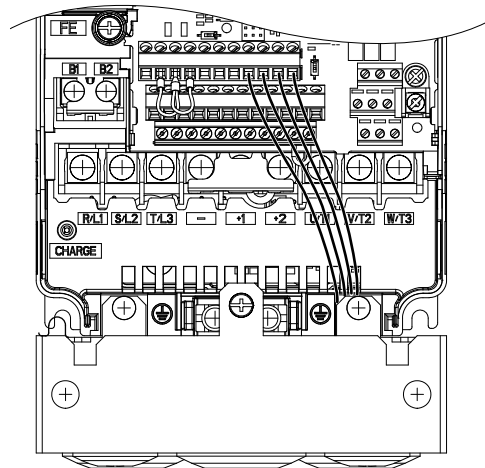
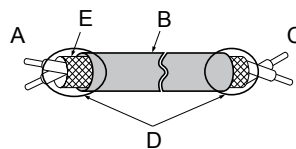

Figure 3.32 Terminal Board Location Inside the Drive

When setting the frequency by analog reference from an external potentiometer, use shielded twisted-pair wires (preparing wire ends as shown in [Figure 3.33](#)) and connect the shield to the ground terminal of the drive.



A – Drive side
B – Insulation
C – Control device side

D – Shield sheath (insulate with tape)
E – Shield

Figure 3.33 Preparing the Ends of Shielded Cables

NOTICE: The analog signal wiring between the drive and the operator station or peripheral equipment should not exceed 50 meters when using an analog signal from a remote source to supply the frequency reference. Failure to comply could result in poor system performance.

◆ Switches and Jumpers on the Terminal Board

The terminal board is equipped with several switches used to adapt the drive I/Os to the external control signals. *Figure 3.34* shows the location of these switches. *Refer to Control I/O Connections on page 104* for setting instructions.

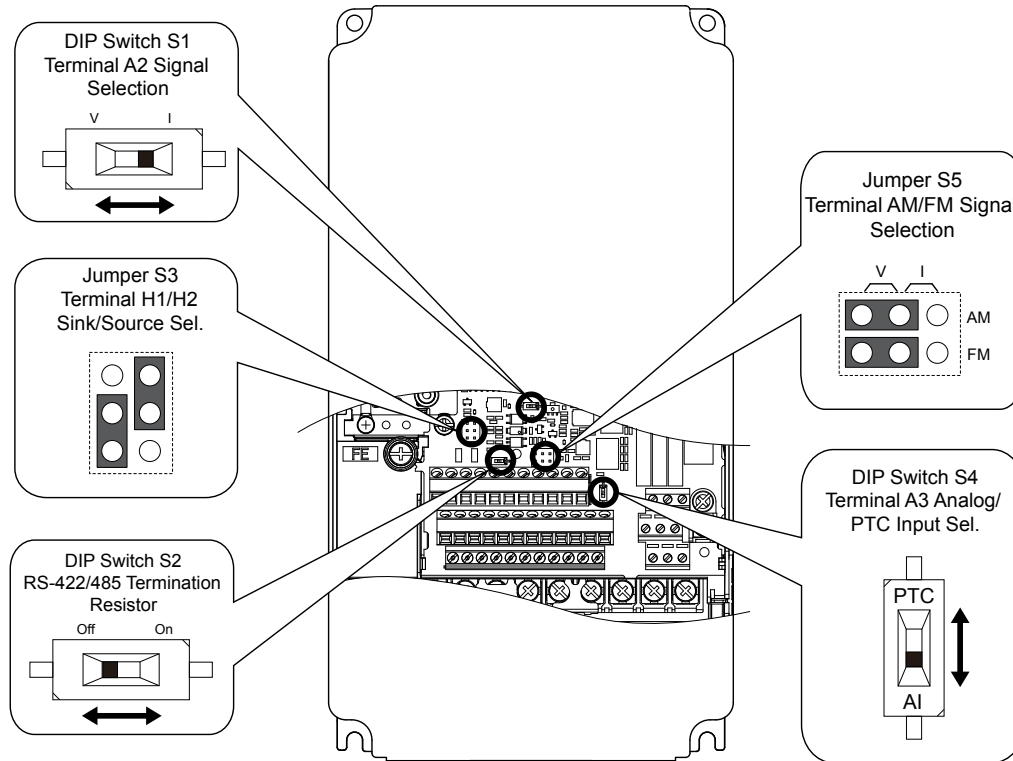

Figure 3.34 Locations of Jumpers and Switches on the Terminal Board

3.10 Control I/O Connections

◆ Sinking/Sourcing Mode Switch for Digital Inputs

Use the wire jumper between terminals SC and SP or SC and SN to select between Sink mode, Source mode or external power supply for the digital inputs S1 to S8 as shown in [Table 3.12](#) (Default: Sink mode, internal power supply).

NOTICE: Do not short terminals SP and SN. Failure to comply will damage the drive.

Table 3.12 Digital Input Sink/Source/External Power Supply Selection

Mode	Drive Internal Power Supply (Terminals SN and SP)	External 24 Vdc Power Supply
Sinking Mode (NPN)		
Sourcing Mode (PNP)		

◆ Sinking/Sourcing Mode Selection for Safe Disable Inputs

Note: Terminals H1, H2, DM+, and DM- on 600 V class models are designed to the functionality, but are not certified to EN61800-5-1, ISO13849 Cat. 3, IEC/EN61508 SIL2, Insulation coordination: class 1.

Use jumper S3 on the terminal board to select between Sink mode, Source mode or external power supply for the Safe Disable inputs H1 and H2 as shown in [Table 3.12](#) (Default: Source mode, internal power supply). *Refer to Switches and Jumpers on the Terminal Board on page 103* for locating jumper S3.

Table 3.13 Safe Disable Input Sink/Source/External Power Supply Selection

Mode	Drive Internal Power Supply	External 24 Vdc Power Supply
Sinking Mode		
Sourcing Mode		

◆ Using the Pulse Train Output

The pulse train output terminal MP can supply power or be used with an external power supply.

NOTICE: Connect peripheral devices in accordance with the specifications. Failure to comply may cause unexpected drive operation, and can damage the drive or connected circuits.

■ Using Power from the Pulse Output Terminal (Source Mode)

The high voltage level of the pulse output terminal depends on the load impedance.

Load Impedance R_L (k Ω)	Output Voltage V_{MP} (V) (insulated)
1.5 k Ω	5 V
4 k Ω	8 V
10 k Ω	10 V

Note: The load resistance needed in order to get a certain high level voltage V_{MP} can be calculated by: $R_L = V_{MP} \cdot 2 / (12 - V_{MP})$

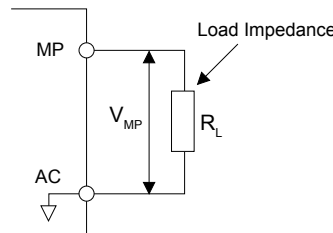

Figure 3.35 Pulse Output Connection Using Internal Voltage Supply

3.10 Control I/O Connections

■ Using External Power Supply (Sink Mode)

The high voltage level of the pulse output signal depends on the external voltage applied. The voltage must be between 12 and 15 Vdc. The load resistance must be adjusted so that the current is lower than 16 mA.

External Power Supply (V)	Load Impedance (kΩ)
12 to 15 Vdc ±10%	1.0 kΩ or higher

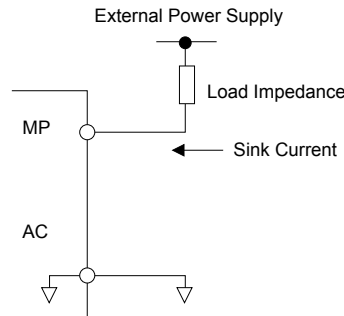

Figure 3.36 Pulse Output Connection Using External Voltage Supply

◆ Terminal A2 Input Signal Selection

Terminal A2 can be used to input either a voltage or a current signal. Select the signal type using switch S1 as explained in [Table 3.14](#). Set parameter H3-09 accordingly as shown in [Table 3.15](#). Refer to [Switches and Jumpers on the Terminal Board on page 103](#) for locating switch S1.

Note: If terminals A1 and A2 are both set for frequency bias (H3-02 = 0 and H3-10 = 0), both input values will be combined to create the frequency reference.

Table 3.14 DIP Switch S1 Settings

Setting	Description
V (left position)	Voltage input (-10 to +10 V or 0 to 10 V)
I (right position)	Current input (4 to 20 mA or 0 to 20 mA): default setting

Table 3.15 Parameter H3-09 Details

No.	Parameter Name	Description	Setting Range	Default Setting
H3-09	Terminal A2 signal level selection	Selects the signal level for terminal A2. 0: 0 to 10 Vdc 1: -10 to 10 Vdc 2: 4 to 20 mA 3: 0 to 20 mA	0 to 3	2

◆ Terminal A3 Analog/PTC Input Selection

Terminal A3 can be configured either as multi-function analog input or as PTC input for motor thermal overload protection. Use switch S4 to select the input function as described in [Table 3.16](#). Refer to [Switches and Jumpers on the Terminal Board on page 103](#) for locating switch S4.

Table 3.16 DIP Switch S4 Settings

Setting	Description
AI (lower position) (default)	Analog input for the function selected in parameter H3-06
PTC (upper position)	PTC input. Parameter H3-06 must be set to E (PTC input)

◆ Terminal AM/FM Signal Selection

The signal type for terminals AM and FM can be set to either voltage or current output using jumper S5 on the terminal board as explained in [Table 3.17](#). When changing the setting of jumper S5, parameters H4-07 and H4-08 must be set accordingly. The default selection is voltage output for both terminals. *Refer to [Switches and Jumpers on the Terminal Board on page 103](#) for locating jumper S5.*

Table 3.17 Jumper S5 Settings





Terminal	Voltage Output	Current Output
Terminal AM		
Terminal FM		

Table 3.18 Parameter H4-07 and H4-08 Details

No.	Parameter Name	Description	Setting Range	Default Setting
H4-07	Terminal AM signal level selection	0: 0 to 10 Vdc 1: -10 to 10 Vdc	0 to 2	0
H4-08	Terminal FM signal level selection	2: 4 to 20 mA		

◆ MEMOBUS/Modbus Termination

This drive is equipped with a built-in termination resistor for the RS-422/485 communication port. DIP switch S2 enables or disabled the termination resistor as shown in [Table 3.19](#). The OFF position is the default. The termination resistor should be placed to the ON position when the drive is the last in a series of slave drives. *Refer to [Switches and Jumpers on the Terminal Board on page 103](#) to locate switch S2.*

Table 3.19 MEMOBUS/Modbus Switch Settings

S2 Position	Description
ON	Internal termination resistor ON
OFF	Internal termination resistor OFF (default setting)

Note: *Refer to [MEMOBUS/Modbus Communications on page 611](#) for details on MEMOBUS/Modbus.*

3.11 Connect to a PC

This drive is equipped with a USB port (type-B).

The drive can connect to a USB port on a PC using a USB 2.0, AB-type cable (sold separately). After connecting the drive to a PC, Yaskawa DriveWizard Plus software can be used to monitor drive performance and manage parameter settings. Contact Yaskawa for more information on DriveWizard Plus.

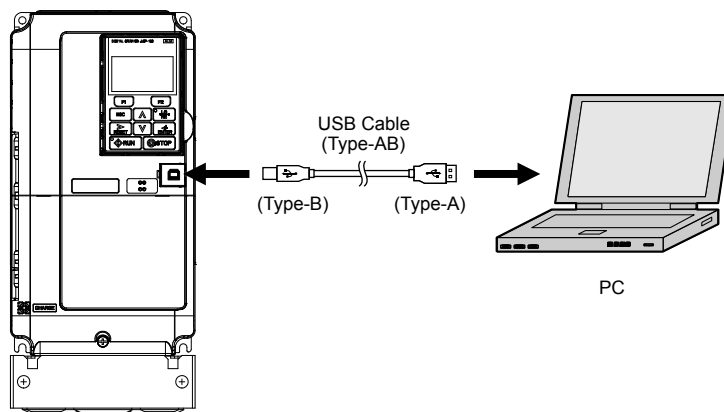

Figure 3.37 Connecting to a PC (USB)

3.12 External Interlock

Systems that may be affected during drive fault conditions should be interlocked with the drive fault output and ready signal.

◆ Drive Ready

When the “Drive ready” signal has been set to one of the multi-function contact outputs, that output will close whenever the drive is ready to accept a Run command or is already running. Under the following conditions the Drive ready signal will switch off and remain off, even if a Run command is entered:

- when the power supply is shut off
- during a fault
- when there is problem with the control power supply
- when a parameter setting error makes the drive unable to run even if a Run command has been entered
- when a fault such as overvoltage or undervoltage is triggered as soon as the Run command is entered
- when the drive is in the Programming mode and will not accept a Run command even when entered

■ Interlock Circuit Example

Two drives running a single application might interlock with the controller using the Drive Ready and Fault output signals as shown below. *Figure 3.38* illustrates how the application would not be able to run if either drive experiences a fault or is unable to supply a Drive Ready signal.

Terminal	Output Signal	Parameter Setting
MA, MB, MC	Fault	–
M1-M2	Drive Ready	H2-01 = 06

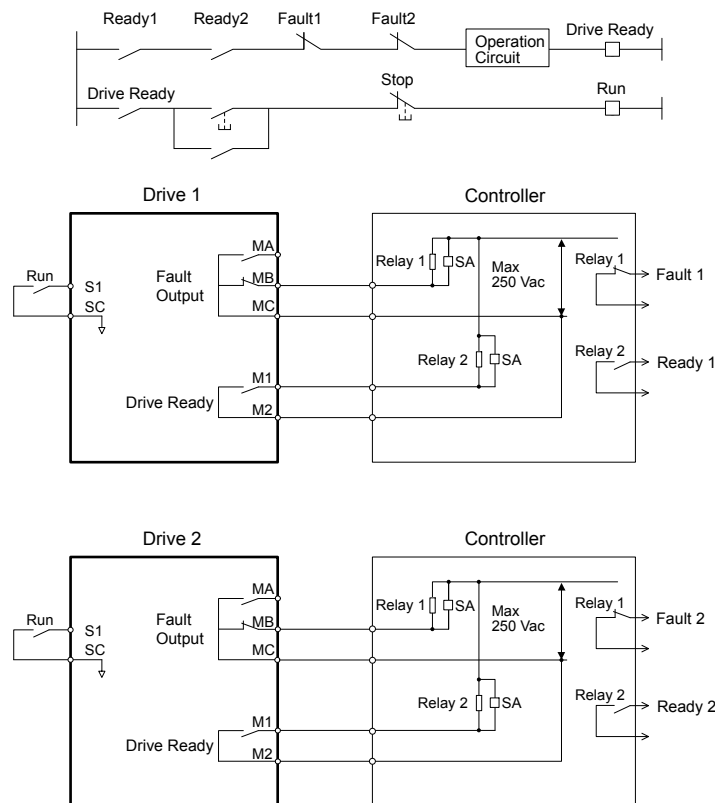
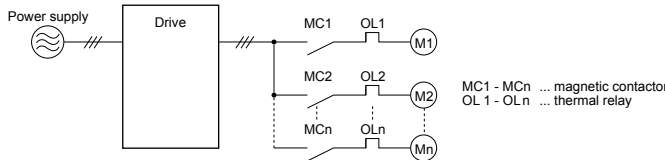

Figure 3.38 Interlock Circuit Example

3.13 Wiring Checklist

<input checked="" type="checkbox"/>	No.	Item	Page(s)
Drive, Peripherals, Option Cards			
<input type="checkbox"/>	1	Check drive model number to ensure receipt of correct model.	35
<input type="checkbox"/>	2	Make sure you have the correct braking resistors, DC link chokes, noise filters, and other peripheral devices.	437
<input type="checkbox"/>	3	Check the option card model number.	437
Installation Area and Physical Setup			
<input type="checkbox"/>	4	Ensure that the area surrounding the drive complies with specifications.	54
Power Supply Voltage, Output Voltage			
<input type="checkbox"/>	5	The voltage from the power supply should be within the input voltage specification range of the drive.	223
<input type="checkbox"/>	6	The voltage rating for the motor should match the drive output specifications.	35
<input type="checkbox"/>	7	Verify that the drive is properly sized to run the motor.	330
Main Circuit Wiring			
<input type="checkbox"/>	8	Confirm proper branch circuit protection as specified by national and local codes.	72
<input type="checkbox"/>	9	Properly wire the power supply to drive terminals R/L1, S/L2, and T/L3. Note: Confirm the following when wiring models 4A0930 and 4A1200: • Remove the jumpers shorting terminals R/L1-R1/L11, S/L2-S1/L21, and T/L3-T1/L31 when operating with 12-phase rectification. <i>Refer to 12-Phase Rectification on page 77</i> for details. • When operating without 12-phase rectification, properly wire terminals R1/L11, S1/L21, and T1/L31 in addition to terminals R/L1, S/L2, and T/L3.	75
<input type="checkbox"/>	10	Properly wire the drive and motor together. The motor lines and drive output terminals R/T1, V/T2, and W/T3 should match in order to produce the desired phase order. If the phase order is incorrect, the drive will rotate in the opposite direction.	96
<input type="checkbox"/>	11	Use 600 Vac vinyl-sheathed wire for the power supply and motor lines.	89
<input type="checkbox"/>	12	Use the correct wire gauges for the main circuit. <i>Refer to Wire Gauges and Tightening Torque on page 89.</i> • Consider the amount of voltage drop when selecting wire gauges. Increase the wire gauge when the voltage drop is greater than 2% of motor rated voltage. Ensure the wire gauge is suitable for the terminal block. Use the following formula to calculate the amount of voltage drop: $\text{Line drop voltage (V)} = \sqrt{3} \times \text{wire resistance } (\Omega/\text{km}) \times \text{wire length (m)} \times \text{current (A)} \times 10^{-3}$ • If the cable between the drive and motor exceeds 50 m, adjust the carrier frequency set to C6-02 accordingly.	96
<input type="checkbox"/>	13	Properly ground the drive. Review page 96.	96
<input type="checkbox"/>	14	Tighten control circuit and grounding terminal screws. <i>Refer to Wire Gauges and Tightening Torque on page 89.</i>	89
<input type="checkbox"/>	15	Set up overload protection circuits when running multiple motors from a single drive.  Note: Close MC1 – MCn before operating the drive. MC1 – MCn cannot be switched off during run.	–
<input type="checkbox"/>	16	Install a magnetic contactor when using a dynamic braking option. Properly install the resistor and ensure that overload protection shuts off the power supply using the magnetic contactor.	449
<input type="checkbox"/>	17	Verify phase advancing capacitors, input noise filters, or GFCIs are NOT installed on the output side of the drive.	–
Control Circuit Wiring			
<input type="checkbox"/>	18	Use twisted-pair line for all drive control circuit wiring.	101
<input type="checkbox"/>	19	Ground the shields of shielded wiring to the GND ⊕ terminal.	101
<input type="checkbox"/>	20	For 3-Wire sequence, set parameters for multi-function contact input terminals S1 – S8, and wire control circuits.	–
<input type="checkbox"/>	21	Properly wire any option cards.	101
<input type="checkbox"/>	22	Check for any other wiring mistakes. Only use a multimeter to check wiring.	–
<input type="checkbox"/>	23	Properly fasten drive control circuit terminal screws. <i>Refer to Wire Gauges and Tightening Torque on page 89.</i>	89
<input type="checkbox"/>	24	Pick up all wire clippings.	–

<input checked="" type="checkbox"/>	No.	Item	Page(s)
<input type="checkbox"/>	25	Ensure that no frayed wires on the terminal block are touching other terminals or connections.	–
<input type="checkbox"/>	26	Properly separate control circuit wiring and main circuit wiring.	–
<input type="checkbox"/>	27	Analog signal line wiring should not exceed 50 m.	–
<input type="checkbox"/>	28	Safe Disable input wiring should not exceed 30 m.	–

This Page Intentionally Blank

Start-Up Programming & Operation

This chapter explains the functions of the digital operator and how to program the drive for initial operation.

4.1	SECTION SAFETY.....	114
4.2	USING THE DIGITAL OPERATOR.....	115
4.3	THE DRIVE AND PROGRAMMING MODES.....	120
4.4	START-UP FLOWCHARTS.....	126
4.5	POWERING UP THE DRIVE.....	131
4.6	APPLICATION SELECTION.....	132
4.7	AUTO-TUNING.....	135
4.8	NO-LOAD OPERATION TEST RUN.....	148
4.9	TEST RUN WITH LOAD CONNECTED.....	150
4.10	VERIFYING PARAMETER SETTINGS AND BACKING UP CHANGES.....	151
4.11	TEST RUN CHECKLIST.....	153

4.1 Section Safety

DANGER

Electrical Shock Hazard

Do not connect or disconnect wiring while the power is on.

Failure to comply will result in death or serious injury.

WARNING

Electrical Shock Hazard

Do not operate equipment with covers removed.

Failure to comply could result in death or serious injury.

The diagrams in this section may include drives without covers or safety shields to illustrate details. Be sure to reinstall covers or shields before operating the drives and run the drives according to the instructions described in this manual.

Do not remove covers or touch circuit boards while the power is on.

Failure to comply could result in death or serious injury.

Prepare a separate holding brake.

Wire the holding brake so when a fault occurs, it is activated by an external sequence and shuts the power off or triggers an emergency switch. Failure to comply could result in death or serious injury.

4.2 Using the Digital Operator

Use the digital operator to enter Run and Stop commands, edit parameters, and display data including fault and alarm information.

◆ Keys and Displays

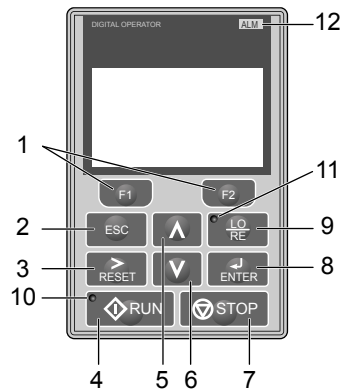

Figure 4.1 Keys and Displays on the Digital Operator

No.	Display	Name	Function
1		Function Key (F1, F2)	The functions assigned to F1 and F2 vary depending on the currently displayed menu. The name of each function appears in the lower half of the display window.
2		ESC Key	<ul style="list-style-type: none"> Returns to the previous display. Moves the cursor one space to the left. Pressing and holding this button will return to the Frequency Reference display.
3		RESET Key	<ul style="list-style-type: none"> Moves the cursor to the right. Resets the drive to clear a fault situation.
4		RUN Key	Starts the drive in LOCAL mode.
5		Up Arrow Key	Scrolls up to display the next item, selects parameter numbers, and increments setting values.
6		Down Arrow Key	Scrolls down to display the previous item, selects parameter numbers, and decrements setting values.
7		STOP Key <1>	Stops drive operation.
8		ENTER Key	<ul style="list-style-type: none"> Enters parameter values and settings. Selects a menu item to move between displays
9		LO/RE Selection Key <2>	Switches drive control between the operator (LOCAL) and an external source (REMOTE) for the Run command and frequency reference.
10		RUN Light	Lit while the drive is operating the motor. Refer to page 117 for details.
11		LO/RE Light	Lit while the operator is selected to run the drive (LOCAL mode). Refer to page 117 for details.
12		ALM LED Light	<i>Refer to ALARM (ALM) LED Displays on page 117.</i>

<1> The STOP key has highest priority. Pressing the STOP key will always cause the drive to stop the motor, even if a Run command is active at any external Run command source. To disable the STOP key priority, set parameter o2-02 to 0.

<2> The LO/RE key can only switch between LOCAL and REMOTE when the drive is stopped. To disable the LO/RE key to prohibit switching between LOCAL and REMOTE, set parameter o2-01 to 0.

◆ LCD Display

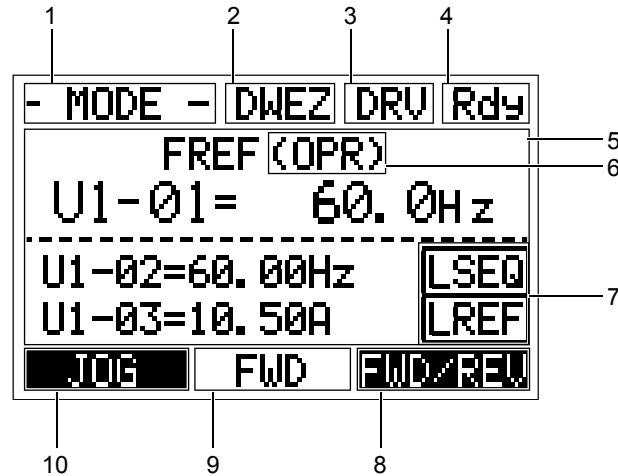







Figure 4.2 LCD Display

Table 4.1 Display and Contents



No.	Name	Display	Content
1	Operation Mode Menus	MODE	Displayed when in Mode Selection.
		MONITR	Displayed when in Monitor Mode.
		VERIFY	Indicates the Verify Menu.
		PRMSET	Displayed when in Parameter Setting Mode.
		A.TUNE	Displayed during Auto-Tuning.
		SETUP	Displayed when in Setup Mode.
2	DriveWorksEZ Function Selection	DWEZ	Displayed when DriveWorksEZ is set to enable. (A1-07 = 1 or 2)
3	Mode Display Area	DRV	Displayed when in Drive Mode.
		PRG	Displayed when in Programming Mode.
4	Ready	Rdy	Indicates the drive is ready to run.
5	Data Display	—	Displays specific data and operation data.
6	Frequency Reference Assignment </>	OPR	Displayed when the frequency reference is assigned to the LCD Operator Option.
		AI	Displayed when the frequency reference is assigned to the Analog Input of the drive.
		COM	Displayed when the frequency reference is assigned to the MEMOBUS/Modbus Communication Inputs of the drive.
		OP	Displayed when the frequency reference is assigned to an Option Unit of the drive.
		RP	Displayed when the frequency reference is assigned to the Pulse Train Input of the drive.
7	LO/RE Display </>	RSEQ	Displayed when the run command is supplied from a remote source.
		LSEQ	Displayed when the run command is supplied from the operator keypad.
		RREF	Displayed when the run command is supplied from a remote source.
		LREF	Displayed when the run command is supplied from the operator keypad.
8	Function Key 2 (F2)	FWD/REV	Pressing switches between forward and reverse.
		DATA	Pressing scrolls to the next display.
		→	Pressing scrolls the cursor to the right.
		RESET	Pressing resets the existing drive fault error.
9	FWD/REV	FWD	Indicates forward motor operation.
		REV	Indicates reverse motor operation.

No.	Name	Display	Content
10	Function Key 1 (F1)	JOG	Pressing  executes the Jog function.
		HELP	Pressing  displays the Help menu.
		←	Pressing  scrolls the cursor to the left.
		HOME	Pressing  returns to the top menu (Frequency Reference).
		ESC	Pressing  returns to the previous display.

- <1> Displayed when in Frequency Reference Mode.
- <2> Displayed when in Frequency Reference Mode and Monitor Mode.







◆ ALARM (ALM) LED Displays

Table 4.2 ALARM (ALM) LED Status and Contents

State	Content	Display
Illuminated	When the drive detects an alarm or error.	
Flashing	<ul style="list-style-type: none"> When an alarm occurs. When an oPE is detected. When a fault or error occurs during Auto-Tuning. 	
Off	Normal operation (no fault or alarm).	

◆ LO/RE LED and RUN LED Indications

Table 4.3 LO/RE LED and RUN LED Indications

LED	Lit	Flashing	Flashing Quickly <1>	Off
	When the operator is selected for Run command and frequency reference control (LOCAL)	—	—	When a device other than the operator is selected for Run command and frequency reference control (REMOTE)
	During run	<ul style="list-style-type: none"> During deceleration to stop When a Run command is input and frequency reference is 0 Hz 	<ul style="list-style-type: none"> While the drive was set to LOCAL, a Run command was entered to the input terminals then the drive was switched to REMOTE. A Run command was entered via the input terminals while the drive was not in Drive Mode. During deceleration when a Fast Stop command was entered. The drive output is shut off by the Safe Disable function. The STOP key was pressed while drive was running in REMOTE. The drive was powered up with b1-17 = 0 (default) while the Run command is active. 	During stop
Examples				

<1> Refer to [Figure 4.3](#) for the difference between “flashing” and “flashing quickly”.

4.2 Using the Digital Operator

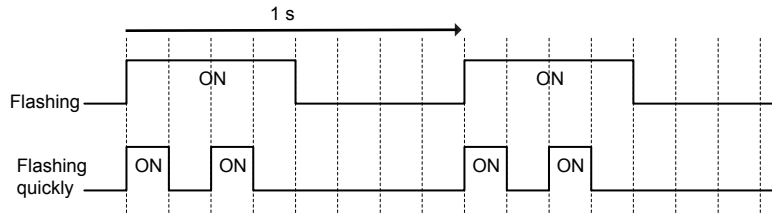

Figure 4.3 RUN LED Status and Meaning

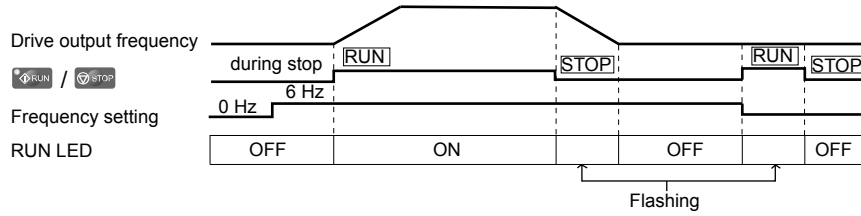

Figure 4.4 RUN LED and Drive Operation

◆ Menu Structure for Digital Operator

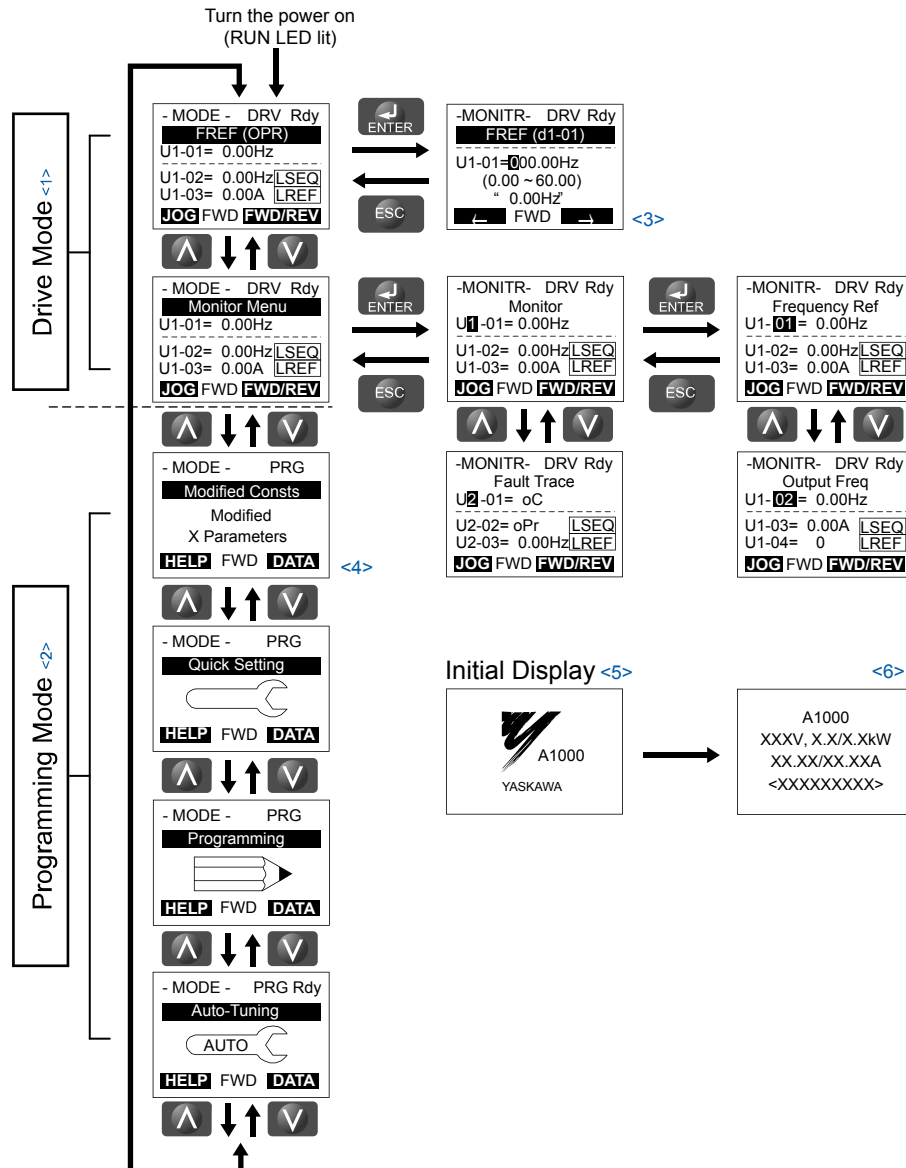

Figure 4.5 Digital Operator Menu and Screen Structure

- <1> Pressing will start the motor.
- <2> Drive cannot operate motor.
- <3> Flashing characters are shown as **0**.
- <4> "X" characters are used as examples in this manual. The LCD Operator will display the actual setting values.
- <5> The Frequency Reference appears after the initial display that shows the product name.
- <6> The information that appears on the display will vary depending on the drive.

4.3 The Drive and Programming Modes



The drive has a Drive Mode to operate the motor and a Programming Mode to edit parameter settings.







Drive Mode: In Drive Mode the user can operate the motor and observe U Monitor parameters. Parameter settings cannot be edited or changed when in Drive Mode.

Programming Mode: In Programming Mode the user can edit and verify parameter settings and perform Auto-Tuning. When the drive is in Programming Mode it will not accept a Run command unless b1-08 is set to 1.

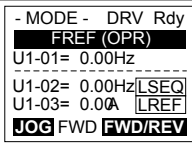
- Note:**
1. If b1-08 is set to 0, the drive will only accept a Run command in Drive Mode. After editing parameters, the user must exit the Programming Mode and enter Drive Mode before operating the motor.
 2. Set b1-08 to 1 to allow motor operation from the drive while in Programming Mode.

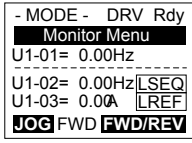
◆ Navigating the Drive and Programming Modes

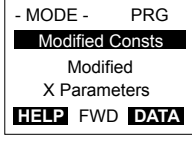
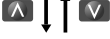
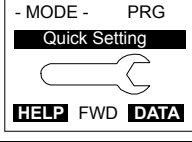
The drive is set to operate in Drive Mode when it is first powered up. Switch between display screens by using the  and  keys.

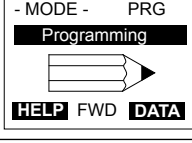
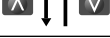
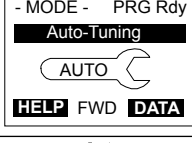
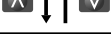
Mode	Contents	Operator Display	Description
Power Up	Frequency Reference (default)		This display screen allows the user to monitor and change the frequency reference while the drive is running. <i>Refer to The Drive and Programming Modes on page 120.</i> Note: The user can select the data displayed when the drive is first powered up with parameter o1-02.
			
Drive Mode	Monitor Display		Lists the monitor parameters (U□-□□ parameters) available in the drive. Press the Enter Key and then use the Up, Down, ESC, and Reset keys to navigate through the drive monitors.
			
Programming Mode	Verify Menu		Lists all parameters that have been edited or changed from default settings. → <i>Refer to Verifying Parameter Changes: Verify Menu on page 123.</i>
			
	Setup Group		A select list of parameters necessary to get the drive operating quickly. → <i>Refer to Using the Setup Group on page 124.</i> Note: Parameters listed in the Setup Group differ depending the Application Preset in parameter A1-06. <i>Refer to Application Selection on page 132.</i>
			
	Parameter Setting Mode		Allows the user to access and edit all parameter settings. → <i>Refer to Parameter List on page 489.</i>
			
	Auto-Tuning Mode		Motor parameters are calculated and set automatically. → <i>Refer to Auto-Tuning on page 135.</i>
			

Mode	Contents	Operator Display	Description
Drive Mode	Frequency Reference	<pre> - MODE - DRV Rdy FREF (OPR) U1-01= 0.00Hz U1-02= 0.00Hz[LSEQ U1-03= 0.00A [LREF JOG FWD FWD/REV </pre>	Returns to the frequency reference display screen.

Drive Mode Details

The following actions are possible in the Drive Mode:

- Run and stop the drive
- Monitor the operation status of the drive (frequency reference, output frequency, output current, output voltage, etc.)
- View information on an alarm
- View a history of alarms that have occurred

Figure 4.6 illustrates how to change the frequency reference from F 0.00 (0 Hz) to F 6.00 (6 Hz) while in the Drive Mode. This example assumes the drive is set to LOCAL.

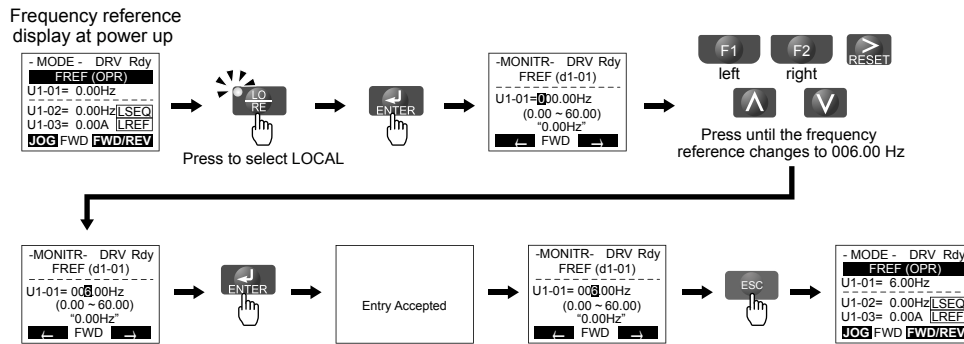

Figure 4.6 Setting the Frequency Reference while in the Drive Mode

Note: The drive will not accept a change to the frequency reference until the ENTER key is pressed after the frequency reference is entered. This feature prevents accidental setting of the frequency reference. To have the drive accept changes to the frequency reference as soon as changes are made without requiring the ENTER key, set o2-05 to 1.

Programming Mode Details

The following actions are possible in the Programming Mode:

- **Parameter Setting Mode:** Access and edit all parameter settings.
- **Verify Menu:** View a list of parameters that have been changed from the default values.
- **Setup Group:** Access a list of commonly used parameters to simplify setup (Refer to *Simplified Setup Using the Setup Group on page 124*).
- **Auto-Tuning Mode:** Automatically calculate and set motor parameters to optimize drive performance.

Changing Parameter Settings or Values

This example explains changing C1-02 (Deceleration Time 1) from 10.0 seconds (default) to 20.0 seconds.

Step		Display/Result
1.	Turn on the power to the drive. The initial display appears.	<pre> - MODE - DRV Rdy FREF (OPR) U1-01= 0.00Hz U1-02= 0.00Hz[LSEQ U1-03= 0.00A [LREF JOG FWD FWD/REV </pre>
2.	Press or until the Parameter Setting Mode screen appears.	<pre> - MODE - PRG Programming HELP FWD DATA </pre>

4.3 The Drive and Programming Modes

Step		Display/Result
3.	Press to enter the parameter menu tree.	
4.	Press or to select the C parameter group.	
5.	Press two times.	
6.	Press or to select parameter C1-02.	
7.	Press to view the current setting value (10.0 s). The leftmost digit flashes.	
8.	Press , , or until the desired number is selected. "1" flashes.	
9.	Press and enter 0020.0.	
10.	Press to confirm the change.	
11.	The display automatically returns to the screen shown in Step 4.	
12.	Press as many times as necessary to return to the initial display.	







◆ Verifying Parameter Changes: Verify Menu

The Verify Menu lists edited parameters from the Programming Mode or as a result of Auto-Tuning. The Verify Menu helps determine which settings have been changed, and is particularly useful when replacing a drive. If no settings have been changed, the Verify Menu will read “None”. The Verify Menu also allows users to quickly access and re-edit any parameter settings that have been changed.

Note: The Verify Menu will not display parameters from the A1 group (except for A1-02) even if those parameters have been changed from their default settings.

The following example is a continuation of the steps above. Here, parameter C1-02 is accessed using the Verify Menu, and is changed again from 10.0 s to 20.0 s.

To check the list of edited parameters:

Step			Display/Result
1.	Turn on the power to the drive. The initial display appears.	→	<pre> -MODE - DRV Rdy FREF (OPR) U1-01= 0.00Hz U1-02= 0.00Hz LSEQ U1-03= 0.00A LREF JOG FWD FWD/REV </pre>
2.	Press  or  until the display shows the top of the Verify Menu.	→	<pre> -MODE - PRG Modified Consts Modified X Parameters HELP FWD DATA </pre>
3.	Press  to enter the list of parameters that have been edited from their original default settings. If parameters other than C1-02 have been changed, use  or  to scroll until C1-02 appears.	→	<pre> -VERIFY - PRG Rdy Accel Time 1 C1-02 = 20.0sec (0.0~6000.0) "10.0sec" Home FWD DATA </pre>
4.	Press  to access the setting value. Left digit flashes.	→	<pre> -VERIFY - PRG Rdy Accel Time 1 C1-01= 20.0sec (0.0~6000.0) "10.0sec" Home FWD DATA </pre>

◆ Simplified Setup Using the Setup Group

The Setup Group lists the basic parameters necessary to set up the drive for an application. This group expedites the startup process for an application by showing only the most important parameters for the application.

■ Using the Setup Group

Figure 4.7 illustrates how to enter and how to change parameters in the Setup Group.

The first display shown when entering the Setup Group is the Application Selection menu. Skipping this display will keep the current Setup Group parameter selection. The default setting for the Setup Group is a group of parameters most commonly use in general-purpose applications. Pressing the ENTER key from the Application Selection menu and selecting an Application Preset will change the Setup Group to parameters optimal for the application selected. *Refer to Application Selection on page 132.*

In this example, the Setup Group is accessed to change b1-01 from 1 to 0. This changes the source of the frequency reference from the control circuit terminals to the digital operator.

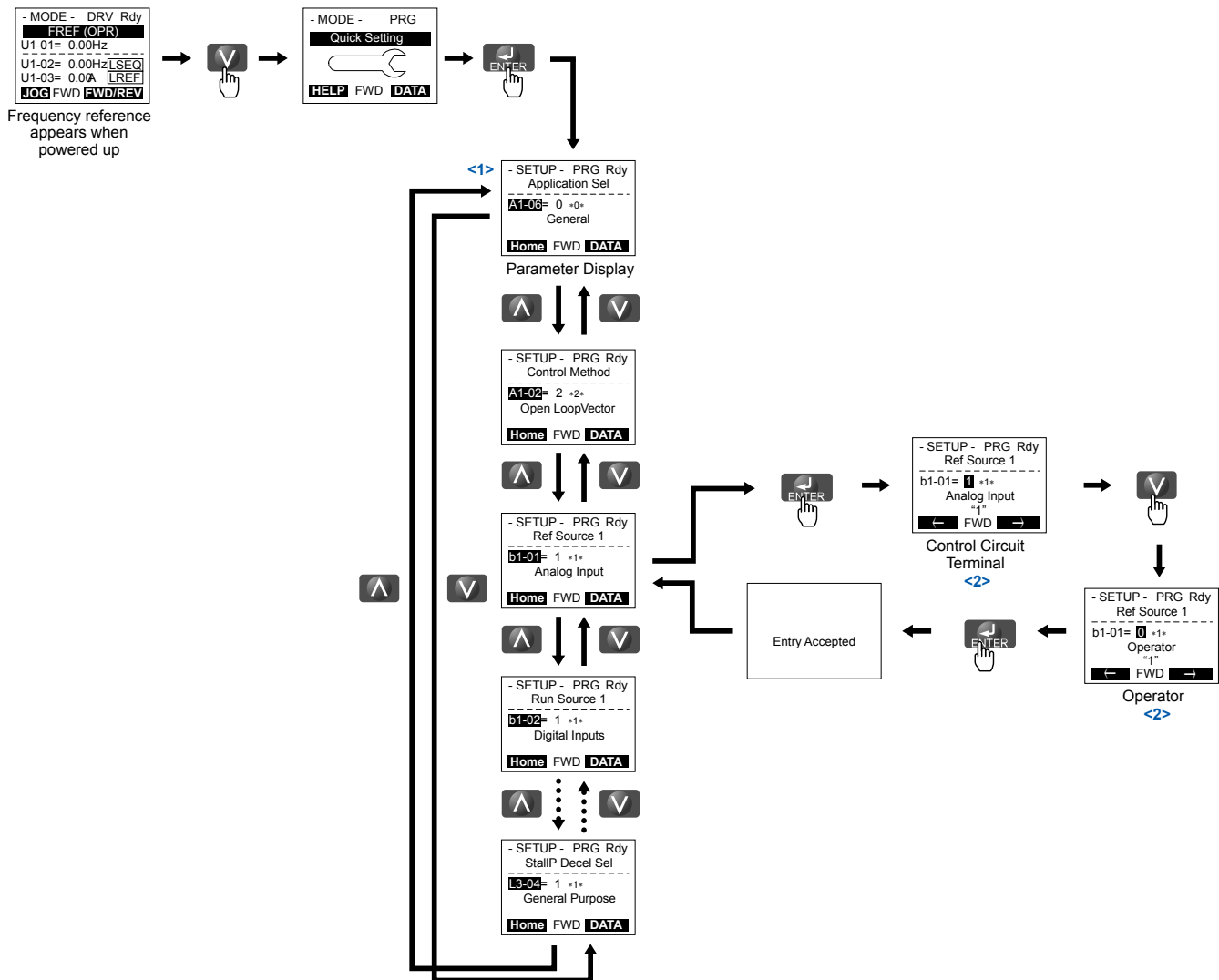

Figure 4.7 Setup Group Example

- <1> Use the up and down arrow keys to scroll through the Setup Group. Press the ENTER key to view or change parameter settings.
- <2> To return to the previous menu without saving changes, press the ESC key.

■ Setup Group Parameters

Table 4.4 lists the parameters available by default in the Setup Group. Selecting an Application Preset in parameter A1-06 or from the Application Selection Menu of the Setup Group automatically changes the parameters selected for the Setup Group. Refer to Application Selection on page 132 for more information.

Use the Programming Mode to access parameters not displayed in the Setup Group.

Table 4.4 Setup Group Parameters

Parameter	Name	Parameter	Name
A1-02	Control Method Selection	E1-03	V/f Pattern Selection
b1-01	Frequency Reference Selection 1	E1-04	Maximum Output Frequency
b1-02	Run Command Selection 1	E1-05	Maximum Voltage
b1-03	Stopping Method Selection	E1-06	Base Frequency
C1-01	Acceleration Time 1	E1-09	Minimum Output Frequency
C1-02	Deceleration Time 1	E1-13	Base Voltage
C6-01	Drive Duty Mode	E2-01	Motor Rated Current
C6-02	Carrier Frequency Selection	E2-04	Number of Motor Poles
d1-01	Frequency Reference 1	E2-11	Motor Rated Power
d1-02	Frequency Reference 2	H4-02	Multi-Function Analog Output Terminal FM Gain
d1-03	Frequency Reference 3	H4-05	Multi-Function Analog Output Terminal AM Gain
d1-04	Frequency Reference 4	L1-01	Motor Overload Protection Function Selection
d1-17	Jog Frequency Reference	L3-04	Stall Prevention Selection during Deceleration
E1-01	Input Voltage Setting		

Note: Parameter availability depends on the control mode set in A1-02; some parameters listed above may not be accessible in all control modes.

◆ Switching Between LOCAL and REMOTE







LOCAL mode is when the drive is set to accept the Run command from the digital operator RUN key. REMOTE mode is when the drive is set to accept the Run command from an external device (i.e., input terminals or serial communications).

WARNING! Sudden Movement Hazard. The drive may start unexpectedly if the Run command is already applied when switching from LOCAL mode to REMOTE mode when b1-07 = 1, resulting in death or serious injury. Be sure all personnel are clear of rotating machinery.

Switch the operation between LOCAL and REMOTE using the LO/RE key on the digital operator or via a digital input.

- Note:**
1. After selecting LOCAL, the LO/RE light will remain lit.
 2. The drive will not allow the user to switch between LOCAL and REMOTE during run.

■ Using the LO/RE Key on the Digital Operator

Step		Display/Result
1.	Turn on the power to the drive. The initial display appears.	→ 
2.	Press  . The LO/RE light will light up. The drive is now in LOCAL. To set the drive for REMOTE operation, press the  key again.	→   → 

■ Using Input Terminals S1 through S8 to Switch between LOCAL and REMOTE

It is possible to switch between LOCAL and REMOTE modes using one of the digital input terminals S1 through S8 (set the corresponding parameter H1-□□ to “1”).

Setting H1-□□ to 1 disables the LO/RE key on the digital operator. Refer to H1: Multi-Function Digital Inputs on page 247 for details.

4.4 Start-Up Flowcharts

These flowcharts summarize steps required to start the drive. Use the flowcharts to determine the most appropriate start-up method for a given application. The charts are quick references to help familiarize the user with start-up procedures.

- Note:**
1. [Refer to Application Selection on page 132](#) to set up the drive using one of the Application Presets.
 3. Function availability differs for drive models 4A0930 and 4A1200. [Refer to Parameter Differences for Drive Models 4A0930 and 4A1200 on page 492](#) for details.

Flowchart	Subchart	Objective	Page
A	–	Basic start-up procedure and motor tuning	127
–	A-1	Simple motor setup using V/f mode	128
	A-2	High-performance operation using Open Loop Vector or Closed Loop Vector motor control	129
	A-3	Setting up the drive to run a permanent magnet (PM) motor Note: PM motor control modes are not available on 600 V class drives, models 5A□□□□.	130

◆ Flowchart A: Basic Start-Up and Motor Tuning

Flowchart A in [Figure 4.8](#) describes a basic start-up sequence that varies slightly depending on the application. Use the drive default parameter settings in simple applications that do not require high precision.

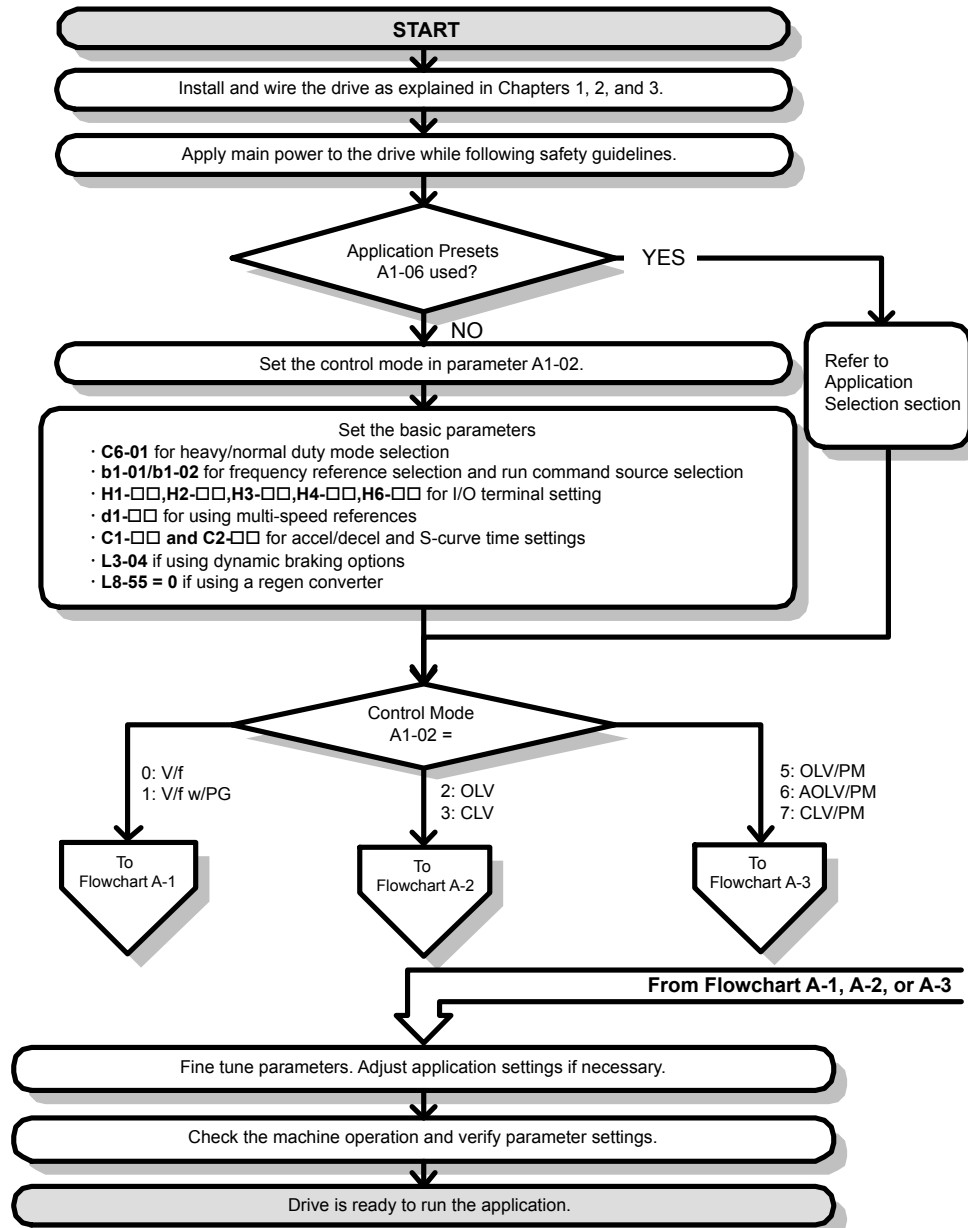

Figure 4.8 Basic Start-Up

- Note:**
1. Execute Stationary Auto-Tuning for Line-to-Line Resistance if the drive has been Auto-Tuned and then moved to a different location where the motor cable length exceeds 50 m.
 2. Perform Auto-Tuning again after installing an AC reactor or other such components to the output side of the drive.

◆ Subchart A-1: Simple Motor Setup Using V/f Control

Flowchart A1 in *Figure 4.9* describes simple motor setup for V/f Control, with or without PG feedback. V/f Control is suited for more basic applications such as fans and pumps. This procedure illustrates Energy Savings and Speed Estimation Speed Search.

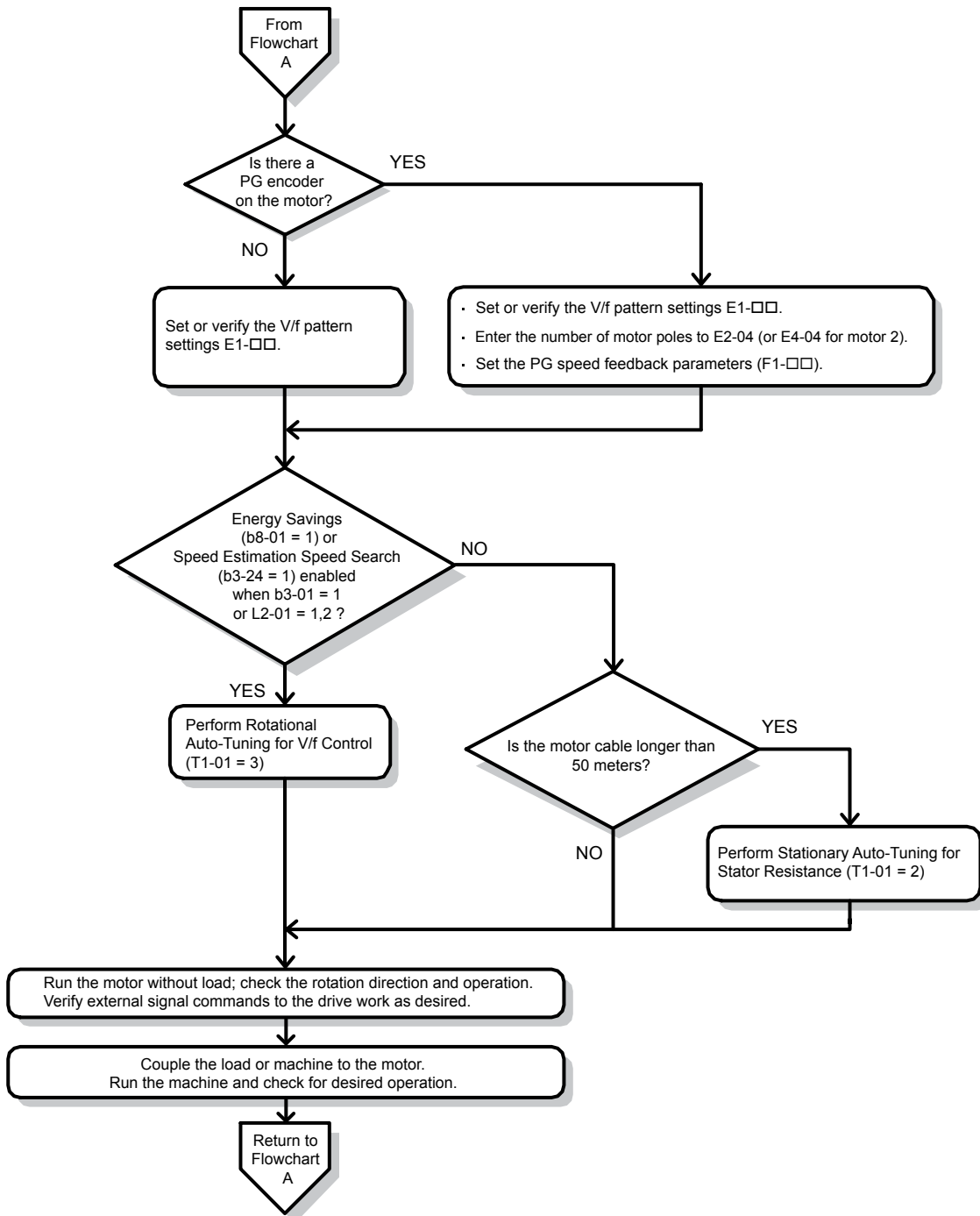

Figure 4.9 Simple Motor Setup with Energy Savings or Speed Search

◆ Subchart A-2: High Performance Operation Using OLV or CLV

Flowchart A2 in *Figure 4.10* describes the setup procedure for high-performance with Open Loop Vector Control or Closed Loop Vector Control, which is appropriate for applications requiring high starting torque and torque limits.

Note: Although the drive sets parameters for the PG encoder during Auto-Tuning, sometimes the direction of the motor and direction of the PG get reversed. Use parameter F1-05 to switch the direction of the PG so that it matches the motor direction.

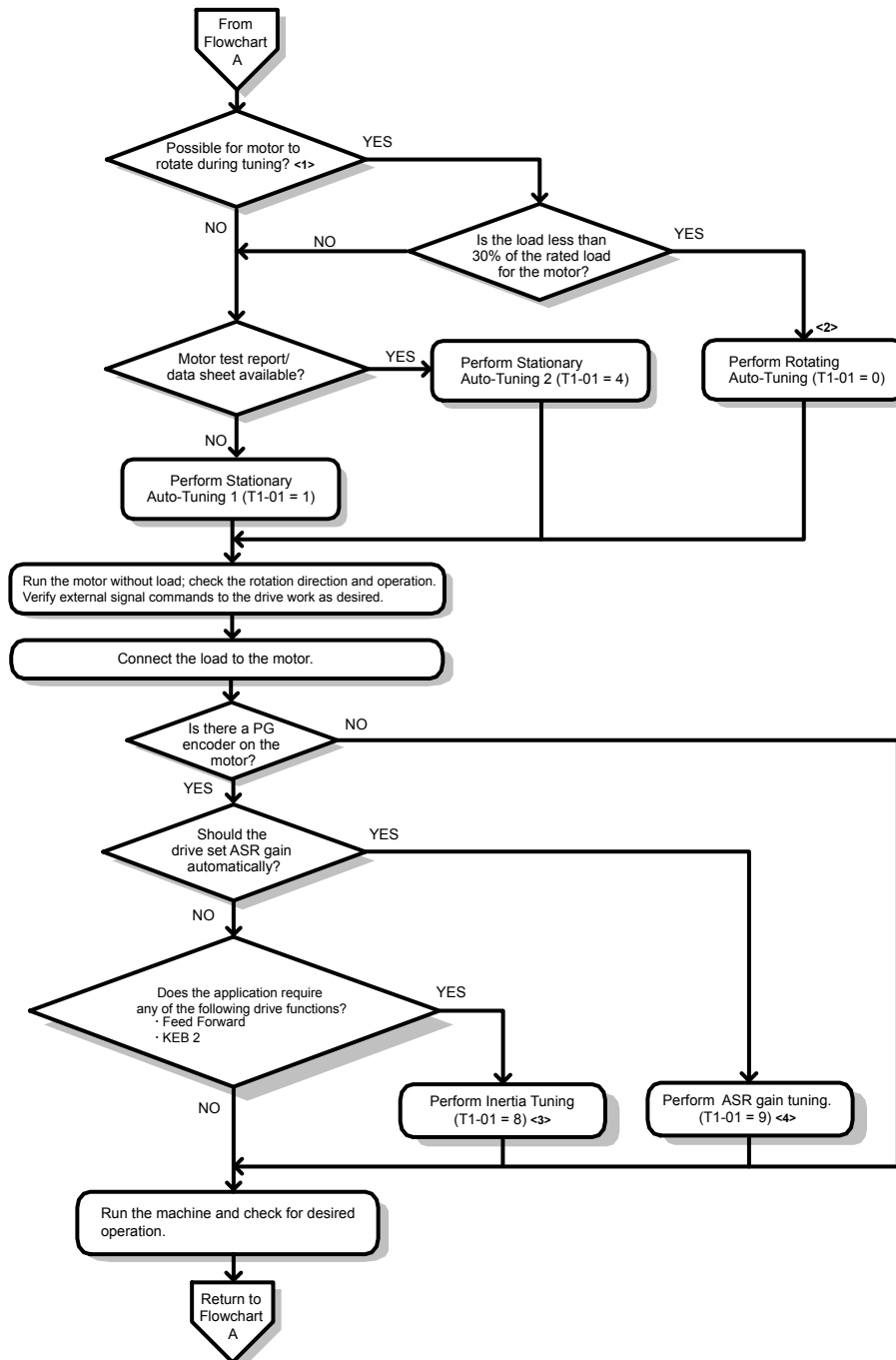

Figure 4.10 Flowchart A2: High Performance Operation Using OLV or CLV

- <1> Decouple the load from the motor to properly perform Rotational Auto-Tuning.
- <2> Rotational Auto-Tuning can still be performed if the load is 30% or less, though Stationary Auto-Tuning may yield better control performance.
- <3> Make sure the motor and load can run freely (i.e., if a brake is mounted, make sure it is released).
- <4> ASR Gain Tuning automatically performs Inertia Tuning and sets parameters related to Feed Forward and the KEB Ride-Thru function.

◆ Subchart A-3: Operation with Permanent Magnet Motors

Note: PM motor control modes are not available on 600 V class drives, models 5A□□□□.

Flowchart A3 in **Figure 4.11** describes the setup procedure for running a PM motor in Open Loop Vector Control. PM motors can be used for more energy-efficient operation in reduced or variable torque applications.

- Note:**
1. Although the drive sets parameters for the PG encoder during Auto-Tuning, sometimes the direction of the motor and direction of the PG get reversed. Use parameter F1-05 to switch the direction of the PG so that it matches the motor direction.
 2. Realign the Z Pulse if the PG encoder is replaced. Set T2-01 to 3 to recalibrate the drive for the new encoder.

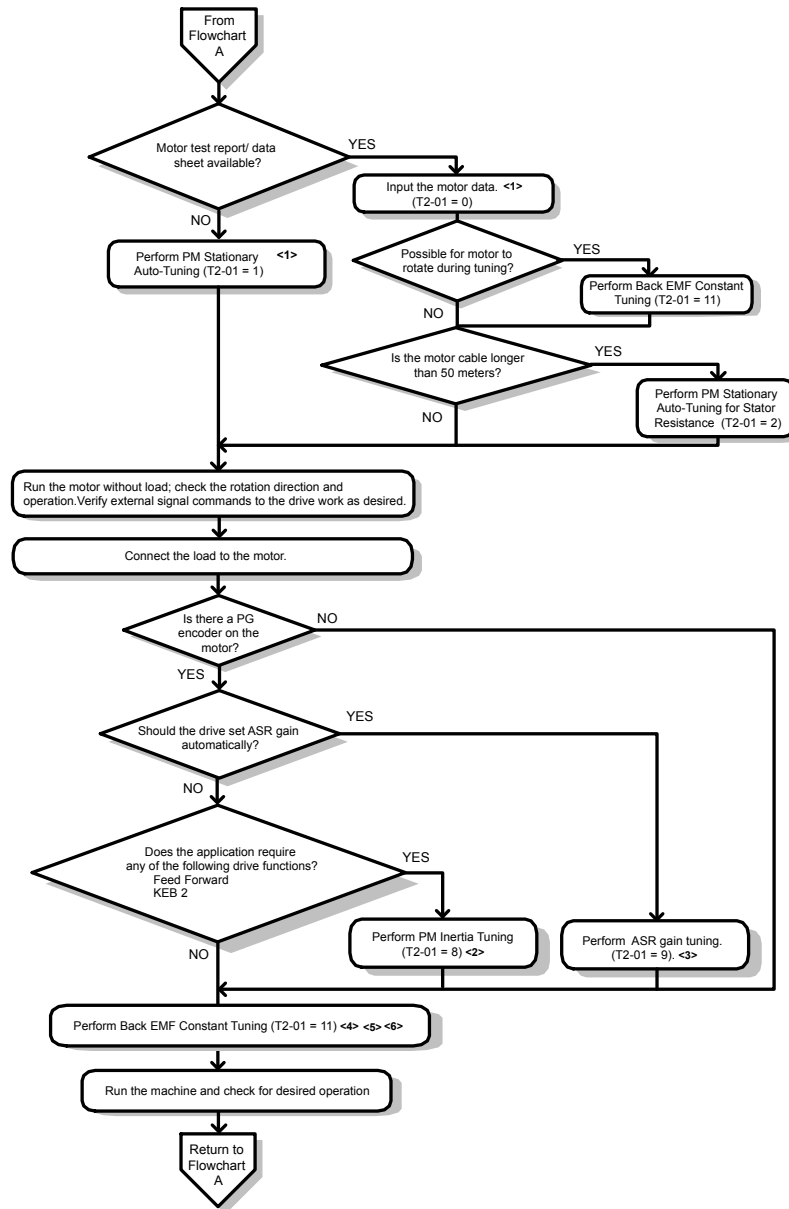

Figure 4.11 Operation with Permanent Magnet Motors

- <1> Enter the motor code to E5-01 when using a Yaskawa PM motor (SMRA Series, SSR1 Series, and SST4 Series). If using a motor from another manufacturer, enter “FFFF”.
- <2> Make sure the motor and load can run freely (i.e., if a brake is mounted, make sure it is released).
- <3> ASR Gain Tuning automatically performs Inertia Tuning and sets parameters related to Feed Forward and the KEB Ride-Thru function.
- <4> Back EMF Constant Tuning automatically measures motor induced voltage and then sets E5-09 when the motor report or data sheets are not available.
- <5> This type of Auto-Tuning is available in drive software versions PRG: 1015 and later.
- <6> This type of Auto-Tuning is not available in models 4A0930 or 4A1200

4.5 Powering Up the Drive

◆ Powering Up the Drive and Operation Status Display

■ Powering Up the Drive



Review the following checklist before turning the power on.

Item to Check	Description
Power supply voltage	200 V class: Three-phase 200 to 240 Vac 50/60 Hz 400 V class: Three-phase 380 to 480 Vac 50/60 Hz 600 V class: Three-phase 500 to 600 Vac 50/60 Hz
	Properly wire the power supply input terminals (R/L1, S/L2, T/L3). <1>
	Check for proper grounding of drive and motor.
Drive output terminals and motor terminals	Properly wire drive output terminals U/T1, V/T2, and W/T3 with motor terminals U, V, and W.
Control circuit terminals	Check control circuit terminal connections.
Drive control terminal status	Open all control circuit terminals (off).
Status of the load and connected machinery	Decouple the motor from the load.

<1> Confirm the following when connecting models 4A0930 and 4A1200: Remove the jumpers on R1/L11, S1/L21, and T1/L31 when using 12-phase rectification. [Refer to 12-Phase Rectification on page 77](#) for details. When operating without 12-phase rectification, properly wire terminals R1/L11, S1/L21, and T1/L31 in addition to terminals R/L1, S/L2, and T/L3.

■ Status Display

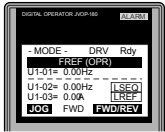
When the power supply to the drive is turned on, the digital operator lights will appear as follows:

Status	Name	Description
Normal Operation		The data display area displays the frequency reference. [DRV] is lit.
Fault	 External fault (example)	Data displayed varies by the type of fault. Refer to Fault Displays, Causes, and Possible Solutions on page 347 for more information. [ALM] and [DRV] are lit.

4.6 Application Selection

Several Application Presets are available to facilitate drive setup for commonly used applications. Selecting one of these Application Presets automatically assigns functions to the input and output terminals and sets a predefined group of parameters to values appropriate for the selected application.

In addition, the parameters most likely to be changed are assigned to the group of User Parameters, A2-01 through A2-16. User Parameters are part of the Setup Group, which provides quicker access by eliminating the need to scroll through multiple menus.

An Application Preset can either be selected from the Application Selection menu in the Setup Group (*Refer to Simplified Setup Using the Setup Group on page 124*) or in parameter A1-06. The following presets can be selected:

- Note:**
1. Application Presets can only be selected if all drive parameters are at their original default settings. It may be necessary to initialize the drive by setting A1-03 to “2220” or “3330” prior to selecting an Application Preset.
 2. Entering a value to A1-06 to enable an Application Preset will fix that value to the parameter. The value cannot be changed without first setting A1-03 to 2220 or 3330 to initialize the drive.

WARNING! Sudden Movement Hazard. Confirm the drive I/O signals and external sequence before performing a test run. Setting parameter A1-06 may automatically change the I/O terminal function from the default setting. Failure to comply may result in death or serious injury.

No.	Parameter Name	Setting Range	Default
A1-06	Application Presets	0: Disabled 1: Water supply pump 2: Conveyor 3: Exhaust fan 4: HVAC 5: Compressor	0

◆ Setting 1: Water Supply Pump Application

Table 4.5 Water Supply Pump: Parameter Settings

No.	Name	Default Setting
A1-02	Control Method Selection	0: V/f Control
b1-04	Reverse Operation Selection	1: Reverse Prohibited
C1-01	Acceleration Time 1	1.0 s
C1-02	Deceleration Time 1	1.0 s
C6-01	Duty Rating	1: Normal Duty (ND)
E1-03	V/f Pattern Selection	F: V/f Pattern Selection
E1-07	Mid Output Frequency	30.0 Hz
E1-08	Mid Output Frequency Voltage	50.0 V
L2-01	Momentary Power Loss Operation Selection	1: Enabled
L3-04	Stall Prevention Selection during Deceleration	1: Enabled

Table 4.6 Water Supply Pump: User Parameters (A2-01 to A2-16)

No.	Parameter Name	No.	Parameter Name
b1-01	Frequency Reference Selection	E1-08	Mid Output Frequency Voltage
b1-02	Run Command Selection	E2-01	Motor Rated Current
b1-04	Reverse Operation Selection	H1-05	Multi-Function Digital Input Terminal S5 Function Selection
C1-01	Acceleration Time 1	H1-06	Multi-Function Digital Input Terminal S6 Function Selection
C1-02	Deceleration Time 1	H1-07	Multi-Function Digital Input Terminal S7 Function Selection
E1-03	V/f Pattern Selection	L5-01	Number of Auto Restart Attempts
E1-07	Mid Output Frequency	–	–

◆ Setting 2: Conveyor Application

Table 4.7 Conveyor: Parameter Settings

No.	Parameter Name	Default Setting
A1-02	Control Method Selection	0: V/f Control
C1-01	Acceleration Time 1	3.0 s
C1-02	Deceleration Time 1	3.0 s
C6-01	Duty Rating	0: Heavy Duty (HD)
L3-04	Stall Prevention Selection during Deceleration	1: Enabled

Table 4.8 Conveyor: User Parameters (A2-01 to A2-16)

No.	Parameter Name	No.	Parameter Name
A1-02	Control Method Selection	C1-02	Deceleration Time 1
b1-01	Frequency Reference Selection	E2-01	Motor Rated Current
b1-02	Run Command Selection	L3-04	Stall Prevention Selection during Deceleration
C1-01	Acceleration Time 1	–	–

◆ Setting 3: Exhaust Fan Application

Table 4.9 Exhaust Fan: Parameter Settings

No.	Parameter Name	Default Setting
A1-02	Control Method Selection	0: V/f Control
b1-04	Reverse Operation Selection	1: Reverse Prohibited
C6-01	Duty Selection	1: Normal Duty (ND)
E1-03	V/f Pattern Selection	F: V/f Pattern Selection
E1-07	Mid Output Frequency	30.0 Hz
E1-08	Mid Output Frequency Voltage	50.0 V
L2-01	Momentary Power Loss Operation Selection	1: Enabled
L3-04	Stall Prevention Selection during Deceleration	1: Enabled

Table 4.10 Exhaust Fan: User Parameters (A2-01 to A2-16)

No.	Parameter Name	No.	Parameter Name
b1-01	Frequency Reference Selection	E1-07	Mid Output Frequency
b1-02	Run Command Selection	E1-08	Mid Output Frequency Voltage
b1-04	Reverse Operation Selection	E2-01	Motor Rated Current
b3-01	Speed Search Selection at Start	H1-05	Multi-Function Digital Input Terminal S5 Function Selection
C1-01	Acceleration Time 1	H1-06	Multi-Function Digital Input Terminal S6 Function Selection
C1-02	Deceleration Time 1	H1-07	Multi-Function Digital Input Terminal S7 Function Selection
E1-03	V/f Pattern Selection	L5-01	Number of Auto Restart Attempts

4.6 Application Selection

◆ Setting 4: HVAC Fan Application

Table 4.11 HVAC Fan: Parameter Settings

No.	Parameter Name	Default Setting
A1-02	Control Method Selection	0: V/f Control
b1-04	Reverse Operation Selection	1: Reverse Prohibited
b1-17	Run Command at Power Up	1: Run command issued, motor operation start
C6-01	Duty Rating	1: Normal Duty (ND)
C6-02	Carrier Frequency Selection	3: 8.0 kHz
H2-03	Terminals P2 Function Selection	39: Watt Hour Pulse Output
L2-01	Momentary Power Loss Operation Selection	2: CPU Power Active - Drive will restart if power returns prior to control power supply shut down.
L8-03	Overheat Pre-Alarm Operation Selection	4: Operation at lower speed
L8-38	Carrier Frequency Reduction	2: Enabled across entire frequency range.

Table 4.12 HVAC Fan: User Parameters (A2-01 to A2-16)

No.	Parameter Name	No.	Parameter Name
b1-01	Frequency Reference Selection	d2-02	Frequency Reference Lower Limit
b1-02	Run Command Selection	E1-03	V/f Pattern Selection
b1-03	Stopping Method Selection	E1-04	Max Output Frequency
b1-04	Reverse Operation Selection	E2-01	Motor Rated Current
C1-01	Acceleration Time 1	H3-11	Terminal A2 Gain Setting
C1-02	Deceleration Time 1	H3-12	Terminal A2 Input Bias
C6-02	Carrier Frequency Selection	L2-01	Momentary Power Loss Operation Selection
d2-01	Frequency Reference Upper Limit	o4-12	kWh Monitor Initial Value Selection

◆ Setting 5: Compressor Application

Table 4.13 Compressor: Parameter Settings

No.	Parameter Name	Default Setting
A1-02	Control Method Selection	0: V/f Control
b1-04	Reverse Operation Selection	1: Reverse Prohibited
C1-01	Acceleration Time 1	5.0 s
C1-02	Deceleration Time 1	5.0 s
C6-01	Duty Rating	0: Heavy Duty (HD)
E1-03	V/f Pattern Selection	F: V/f Pattern Selection
L2-01	Momentary Power Loss Operation Selection	1: Enabled
L3-04	Stall Prevention Selection during Deceleration	1: Enabled

Table 4.14 Compressor: User Parameters (A2-01 to A2-16):

No.	Parameter Name	No.	Parameter Name
b1-01	Frequency Reference Selection	E1-03	V/f Pattern Selection
b1-02	Run Command Selection	E1-07	Mid Output Frequency
b1-04	Reverse Operation Selection	E1-08	Mid Output Frequency Voltage
C1-01	Acceleration Time 1	E2-01	Motor Rated Current
C1-02	Deceleration Time 1	–	–

4.7 Auto-Tuning

◆ Types of Auto-Tuning

The drive offers different types of Auto-Tuning for induction motors and permanent magnet motors. The type of Auto-Tuning used differs further based on the control mode and other operating conditions. Refer to the tables below to select the type of Auto-Tuning that best suits the application. [Refer to Start-Up Flowcharts on page 126](#) for directions on executing Auto-Tuning.

Note: The drive will only show Auto-Tuning parameters that are valid for the control mode that has been set in A1-02. If the control mode is for an induction motor, the Auto-Tuning parameters for PM motors will not be available. If the control mode is for a PM motor, the Auto-Tuning parameters for induction motors will not be available. Inertia Tuning and ASR Gain Tuning parameters and setting options will be visible only when the drive is set for operation with CLV or CLV/PM.

■ Auto-Tuning for Induction Motors

This feature automatically sets the V/f pattern and motor parameters E1-□□ and E2-□□ (E3-□□, E4-□□ for motor 2) for an induction motor. Additionally, the feature also sets some F1-□□ parameters for speed feedback detection in Closed Loop Vector.

Table 4.15 Types of Auto-Tuning for Induction Motors

Type	Setting	Application Conditions and Benefits	Control Mode			
			V/f	V/f w/PG	OLV	CLV
Rotational Auto-Tuning	T1-01 = 0	<ul style="list-style-type: none"> Motor can be decoupled from the load and rotate freely while Auto-Tuning is performed. Motor and load cannot be decoupled but the motor load is below 30%. Rotational Auto-Tuning gives the most accurate results, and is recommended if possible. 	–	–	YES	YES
Stationary Auto-Tuning 1	T1-01 = 1	<ul style="list-style-type: none"> Motor and load cannot be decoupled and the load is higher than 30%. A motor test report listing motor data is not available. Automatically calculates motor parameters needed for vector control. 	–	–	YES	YES
Stationary Auto-Tuning 2	T1-01 = 4	<ul style="list-style-type: none"> Motor and load cannot be decoupled and the load is higher than 30%. A motor test report is available. After entering the no-load current and the rated slip, the drive calculates and sets all other motor-related parameters. 	–	–	YES	YES
Stationary Auto-Tuning for Line-to-Line Resistance	T1-01 = 2	<ul style="list-style-type: none"> The drive is used in V/f Control and other Auto-Tuning selections are not possible. Drive and motor capacities differ. Tunes the drive after the cable between the drive and motor has been replaced with a cable over 50 m long. Assumes Auto-Tuning has already been performed. Should not be used for any vector control modes unless the motor cable has changed. 	YES	YES	YES	YES
Rotational Auto-Tuning for V/f Control	T1-01 = 3	<ul style="list-style-type: none"> Recommended for applications using Speed Estimation Speed Search or using the Energy Saving function in V/f Control. Assumes motor can rotate while Auto-Tuning is executed. Increases accuracy for certain functions like torque compensation, slip compensation, Energy Saving, and Speed Search. 	YES	YES	–	–

[Table 4.16](#) lists the data that must be entered for Auto-Tuning. Make sure this data is available before starting Auto-Tuning. The necessary information is usually listed on the motor nameplate or in the motor test report provided by the motor manufacturer. [Refer to Subchart A-1: Simple Motor Setup Using V/f Control on page 128](#) and [Refer to Subchart A-2: High Performance Operation Using OLV or CLV on page 129](#) for details on Auto-Tuning processes and selections.

4.7 Auto-Tuning

Table 4.16 Auto-Tuning Input Data

Input Value	Input Parameter	Unit	Tuning Type (T1-01)				
			0 Standard	1 Stationary 1	2 Line-to-Line Resistance	3 Rotational for V/f Control	4 Stationary 2
Control Mode	A1-02	–	2, 3	2, 3	0, 1, 2, 3	0, 1	2, 3
Motor rated power	T1-02	kW	YES	YES	YES	YES	YES
Motor rated voltage	T1-03	Vac	YES	YES	–	YES	YES
Motor rated current	T1-04	A	YES	YES	YES	YES	YES
Motor rated frequency	T1-05	Hz	YES	YES	–	YES	YES
Number of motor poles	T1-06	-	YES	YES	–	YES	YES
Motor rated Speed	T1-07	r/min	YES	YES	–	YES	YES
PG Number of pulses per revolution	T1-08	-	YES </>	YES </>	–	–	YES </>
Motor no-load current	T1-09	A	–	YES	–	–	YES
Motor rated Slip	T1-10	Hz	–	–	–	–	YES
Motor iron loss	T1-11	W	–	–	–	YES	–

</> Input data is needed for CLV/PM only.

■ Auto-Tuning for Permanent Magnet Motors

Note: PM motor control modes are not available on 600 V class drives, models 5A□□□□.

Automatically sets the V/f pattern and motor parameters E1-□□ and E5-□□ when a PM motor is used. Additionally, the feature also sets some F1-□□ parameters for speed feedback detection in Closed Loop Vector.

Table 4.17 Types of Auto-Tuning for Permanent Magnet Motors

Type	Setting	Application Conditions and Benefits	Control Mode		
			OLV/PM	AOLV/PM	CLV/PM
PM Motor Parameter Settings	T2-01 = 0	<ul style="list-style-type: none"> Motor does not rotate during Auto-Tuning. Motor test report or motor data similar to Table 4.18 are available. 	YES	YES	YES
PM Stationary Auto-Tuning	T2-01 = 1	<ul style="list-style-type: none"> A motor test report listing motor data is not available. Drive automatically calculates and sets motor parameters. 	YES	YES	YES
PM Stationary Auto-Tuning for Stator Resistance	T2-01 = 2	<ul style="list-style-type: none"> Useful to tune the drive when the motor data were set up manually or by motor code and the cable is longer than 50 m. Should also be performed if the cable length has changed after prior tuning. 	YES	YES	YES
Z Pulse Offset Tuning	T2-01 = 3	<ul style="list-style-type: none"> PG encoder has been replaced. Calculates the Z Pulse offset. Requires the motor to rotate with no load or very low load. 	–	–	YES
Back EMF Constant Tuning	T2-01 = 11	<ul style="list-style-type: none"> Use when a motor test is not available. Tunes the motor induction voltage only. Should be performed after motor data are set and the encoder offset is adjusted. The motor must be uncoupled from the mechanical system (remove loads). 	–	–	YES

[Table 4.18](#) lists the data that must be entered for Auto-Tuning. Make sure the data is available before starting Auto-Tuning. The necessary information is usually listed on the motor nameplate or in the motor test report provided by the motor manufacturer. [Refer to Subchart A-3: Operation with Permanent Magnet Motors on page 130](#) for details on the Auto-Tuning process and selection.

Table 4.18 Auto-Tuning Input Data

Input Value	Input Parameter	Unit	Tuning Type (T2-01)							
			0 Motor Parameter Settings			1 Stationary		2 Stationary Stator Resistance	3 Z-Pulse Offset	11 Back EMF Constant
Control Mode	A1-02	–	5, 6, 7	5	6, 7	5	6, 7	5, 6, 7	7	7
Motor Code (Hex.)	T2-02	–	<1>	<1>	<1>	–	–	–	–	–
Motor Type	T2-03	–	–	–	–	YES	YES	–	–	–
Motor Rated Power	T2-04	kW	–	YES	YES	YES	YES	–	–	–
Motor Rated Voltage	T2-05	Vac	–	YES	YES	YES	YES	–	–	–
Motor Rated Current	T2-06	A	–	YES	YES	YES	YES	YES	–	–
Motor Rated Frequency	T2-07	Hz	–	YES	–	YES	–	–	–	–
Number of Motor Poles	T2-08	–	–	YES	YES	YES	YES	–	–	–
Motor Rated Speed	T2-09	r/min	–	–	YES	–	YES	–	–	–
Stator Single-phase Resistance	T2-10	Ω	YES	YES	YES	–	–	–	–	–
d-Axis Inductance	T2-11	mH	YES	YES	YES	–	–	–	–	–
q-Axis Inductance	T2-12	mH	YES	YES	YES	–	–	–	–	–
Induced Voltage Constant Unit Selection	T2-13	mVs/ rad (elec.)	YES	YES	YES	–	–	–	–	–
Voltage Constant <2>	T2-14	mVmin (mech.)	YES	YES	YES	–	–	–	–	–
Tuning Pull-in Current	T2-15	A	–	–	–	YES	YES	–	–	–
PG Number of Pulses Per Revolution	T2-16	–	YES <2>	–	YES <2>	–	YES <2>	–	–	–
Z Pulse Offset	T2-17	deg (mech.)	YES <2>	–	YES <2>	–	YES <2>	–	–	–

<1> Input the motor code when using a Yaskawa motor. Select “FFFF” when using a motor from another manufacturer.

<2> Input data is needed for CLV/PM only.

<3> Dependent upon T2-13 setting.

■ Inertia Tuning and Speed Control Loop Auto-Tuning

Inertia Tuning can be performed when the drive is using CLV control for either IM or PM motors. Inertia Tuning automatically calculates load and motor inertia, and optimizes settings related to the KEB Ride-Through function (KEB 2) and Feed Forward control.

ASR Gain Auto-Tuning performs the same operation as Inertia Tuning, while also optimizing speed control loop settings.

Table 4.19 Inertia and Speed Control Loop Tuning

Type	Setting		Application Conditions and Benefits	Control Mode	
	IM Motor	PM Motor		CLV	CLV/PM
Inertia Tuning	T1-01 = 8	T2-01 = 8	Allows the motor to rotate at a certain speed and applies a test signal. The response to the test signal is analyzed and the necessary adjustments are made to parameters controlling the Feed Forward and KEB Ride-Through functions (KEB 2, L2-29 = 1).	YES	YES
ASR Gain Auto-Tuning	T1-01 = 9	T2-01 = 9	Performs the same operation as Inertia Tuning, while also adjusting the ASR gain according to the test signal response.	YES	YES

Table 4.20 explains the data that must be entered to perform the Inertia Tuning and ASR Gain Auto-Tuning. Refer to Auto-Tuning for Permanent Magnet Motors on page 136 for details.

4.7 Auto-Tuning

Table 4.20 Auto-Tuning Input Data

Input Value	Input Parameter	Unit	Tuning Type (T1-01 or T2-01)	
			8 Inertia Tuning	9 ASR Gain Tuning
Control Mode	A1-02	–	3, 7	3, 7
Test signal frequency	T3-01	Hz	YES	YES
Test signal amplitude	T3-02	rad	YES	YES
Motor inertia	T3-03	kgm ²	YES	YES
System response frequency	T3-04	Hz	–	YES

◆ Before Auto-Tuning the Drive

Check the items below before Auto-Tuning the drive.

■ Basic Auto-Tuning Preparations

- Auto-Tuning requires the user to input data from the motor nameplate or motor test report. Make sure this data is available before Auto-Tuning the drive.
- For best performance, the drive input supply voltage must be at least equal to or greater than the motor rated voltage.
 - Note:** Better performance is possible when using a motor with a base voltage that is lower than the input supply voltage (20 V for 200 V class models, 40 V for 400 V class models, and 60 V for 600 V class models). This is particularly important when operating the motor above 90% of base speed, where high torque precision is required.
- To cancel Auto-Tuning, press the STOP key on the digital operator.
- When using a motor contactor, make sure it is closed throughout the Auto-Tuning process.
- When using Auto-Tuning for motor 2, make sure motor 2 is connected to the drive output when performing the tuning.

Table 4.21 describes digital input and output terminal operation while Auto-Tuning is executed.

Table 4.21 Auto-Tuning Input Data

Motor Type	Auto-Tuning Type	Digital Input	Digital Output
IM Motor	Rotational Auto-Tuning	Digital input functions are disabled.	Functions the same as during normal operation
	Stationary Auto-Tuning 1		Maintains the status at the start of Auto-Tuning
	Stationary Auto-Tuning 2		
	Stationary Auto-Tuning for Line-to-Line Resistance		
	Rotational Auto-Tuning for V/f Control		
PM Motor <99>	PM Motor Parameter Settings		Digital output functions are disabled.
	PM Stationary Auto-Tuning		Maintains the status at the start of Auto-Tuning
	PM Stationary Auto-Tuning for Stator Resistance		
	Z Pulse Offset Tuning		
	Back EMF Constant Tuning		
IM and PM Motors	Inertia Tuning	Functions the same as during normal operation.	
	ASR Gain Auto-Tuning	Functions the same as during normal operation	

<99> PM motor control modes are not available on 600 V class drives, models 5A□□□□.

■ Notes on Rotational Auto-Tuning

- Decouple the load from the motor to achieve optimal performance from Rotational Auto-Tuning. Rotational Auto-Tuning is best suited for applications requiring high performance over a wide speed range.
- If it is not possible to decouple the motor and load, reduce the load so it is less than 30% of the rated load. Performing Rotational Auto-Tuning with a higher load will set motor parameters incorrectly, and can cause irregular motor rotation.
- Ensure the motor-mounted brake is fully released, if installed.
- Connected machinery should be allowed to rotate the motor.

■ Notes on Stationary Auto-Tuning

Stationary Auto-Tuning modes analyze motor characteristics by injecting current into the motor for approximately one minute.

WARNING! Electrical Shock Hazard. When executing stationary Auto-Tuning, the motor does not rotate but power is applied. Do not touch the motor until Auto-Tuning is completed. Failure to comply may result in injury or death from electrical shock.

WARNING! Sudden Movement Hazard. If installed, do not release the mechanical brake during Stationary Auto-Tuning. Inadvertent brake release may cause damage to equipment or injury to personnel. Ensure that the mechanical brake release circuit is not controlled by the drive multi-function digital outputs.

Stationary Auto-Tuning 1 and 2

- Perform when using a vector control mode and Rotational Auto-Tuning cannot be performed.
- Check the area around the motor to ensure that nothing will accidentally cause the motor to rotate during the Auto-Tuning process.
- Use Stationary Auto-Tuning 1 when the motor test report is not available. Use Stationary Auto-Tuning 2 when the motor test report is available.

Stationary Auto-Tuning for Line-to-Line Resistance and PM Motor Stator Resistance

Note: PM motor control modes are not available on 600 V class drives, models 5A□□□□.

- Perform when entering motor data manually while using motor cables longer than 50 m.
- If the motor cables have been replaced with cables more than 50 m long after Auto-Tuning has already been performed, use Stationary Auto-Tuning for line-to-line resistance.

■ Notes on Inertia Tuning and ASR Gain Auto-Tuning

WARNING! Electrical Shock Hazard. When executing Inertia Tuning or ASR Gain Auto-Tuning, voltage is applied to the motor even before it rotates. Do not touch the motor until Auto-Tuning is completed. Failure to comply may result in injury or death from electrical shock.

- Perform both tuning methods with the machine connected to the motor, but without the load applied.
- The motor will rotate during the Auto-Tuning process. Make sure the areas around the motor and connected machinery are clear.
- The drive will let the system rotate at a certain speed while superimposing a sine wave test signal. Make sure this tuning process does not cause any problem or malfunction in the machine before using it.
- Ensure the motor-mounted brake is fully released if installed.
- Connected machinery should be allowed to rotate the motor.

◆ Auto-Tuning Interruption and Fault Codes

If tuning results are abnormal or the STOP key is pressed before completion, Auto-Tuning will be interrupted and a fault code will appear on the digital operator.

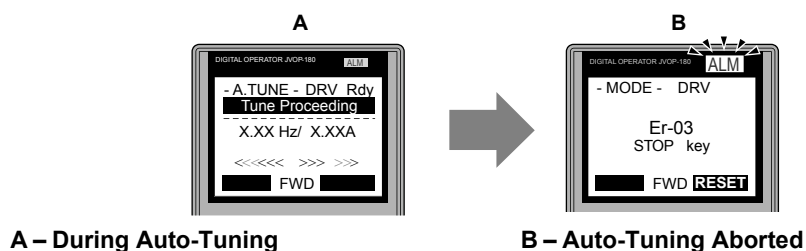

Figure 4.12 Auto-Tuning Aborted Display

◆ Auto-Tuning Operation Example

The following example demonstrates Rotational Auto-Tuning when using OLV (A1-02 = 2) and CLV (A1-02 = 3).

4.7 Auto-Tuning

■ Selecting the Type of Auto-Tuning

Step			Display/Result
1.	Turn on the power to the drive. The initial display appears.	➔	<pre> - MODE - DRV Rdy FREF (OPR) U1-01= 0.00Hz ----- U1-02= 0.00Hz LSEQ U1-03= 0.00A LREF JOG FWD FWD/REV </pre>
2.	Press or until the Auto-Tuning display appears.	➔	<pre> - MODE - PRG Auto-Tuning AUTO HELP FWD DATA </pre>
3.	Press to begin setting parameters.	➔	<pre> - A.TUNE - PRG Rdy Tuning Mode Sel T1-01= 0 +0+ StandardTuning ESC FWD DATA </pre>
4.	Press to display the value for T1-01. </>	➔	<pre> - A.TUNE - PRG Rdy Tuning Mode Sel T1-01= 0 +0+ StandardTuning "0" ← FWD → </pre>
5.	Save the setting by pressing .	➔	<pre> Entry Accepted </pre>
6.	The display automatically returns to the display shown in Step 3.	➔	<pre> - A.TUNE - PRG Rdy Tuning Mode Sel T1-01= 0 +0+ StandardTuning ESC FWD DATA </pre>

</> T1-00 will appear on the display when one of the multi-function inputs has been set to switch between motor 1 and motor 2 (H1-□□ = 16).

■ Enter Data from the Motor Nameplate

After selecting the type of Auto-Tuning, enter the data required from the motor nameplate.

Note: These instructions continue from Step 6 in “Selecting the Type of Auto-Tuning”.

Step			Display/Result
1.	Press to access the motor output power parameter T1-02.	➔	<pre> - A.TUNE - PRG Rdy Mtr Rated Power T1-02= 0.75kW (0.00 ~ 650.00) "0.75kW" ESC FWD DATA </pre>
2.	Press to view the default setting.	➔	<pre> - A.TUNE - PRG Rdy Mtr Rated Power T1-02= 000.75kW (0.00 ~ 650.00) "0.75kW" ← FWD → </pre>
3.	Press left, right, , , and to enter the motor power nameplate data in kW.	➔	<pre> - A.TUNE - PRG Rdy Mtr Rated Power T1-02= 000.40kW (0.00 ~ 650.00) "0.75kW" ← FWD → </pre>
4.	Press to save the setting.	➔	<pre> Entry Accepted </pre>
5.	The display automatically returns to the display in Step 1.	➔	<pre> - A.TUNE - PRG Rdy Mtr Rated Power T1-02= 0.40kW (0.00 ~ 650.00) "0.75kW" ESC FWD DATA </pre>

Step		Display/Result
6.	Repeat Steps 1 through 5 to set the following parameters: <ul style="list-style-type: none"> T1-03, Motor Rated Voltage T1-04, Motor Rated Current T1-05, Motor Base Frequency T1-06, Number of Motor Poles T1-07, Motor Base Frequency T1-09, Motor No-Load Current (Stationary Auto-Tuning 1 or 2 only) T1-10, Motor Rated Slip (Stationary Auto-Tuning 2 only) 	<div style="border: 1px solid black; padding: 5px; margin-bottom: 10px;"> -A.TUNE - PRG Rated Voltage ----- T1-03= 200.0VAC (0.0 ~ 255.0) "200.0VAC" ESC FWD DATA </div> <div style="text-align: center;">↓</div> <div style="border: 1px solid black; padding: 5px;"> -A.TUNE - PRG Mtr Rated Slip ----- T1-10= X.XX Hz (0.00 ~ 20.00) "X.XX Hz" ESC FWD DATA </div>

- Note:**
- For details on each setting, [Refer to T1: Parameter Settings during Induction Motor Auto-Tuning on page 141.](#)
 - To execute Stationary Auto-Tuning for line-to-line resistance only, set parameters T1-02 and T1-04.

Starting Auto-Tuning



WARNING! Sudden Movement Hazard. The drive and motor may start unexpectedly during Auto-Tuning, which could result in death or serious injury. Ensure the area surrounding the drive motor and load are clear before proceeding with Auto-Tuning.

WARNING! Electrical Shock Hazard. High voltage will be supplied to the motor when Stationary Auto-Tuning is performed even with the motor stopped, which could result in death or serious injury. Do not touch the motor until Auto-Tuning has been completed.

NOTICE: Rotational Auto-Tuning will not function properly if a holding brake is engaged on the load. Failure to comply could result in improper operation of the drive. Ensure the motor can freely spin before beginning Auto-Tuning.

Enter the required information from the motor nameplate. Press  to proceed to the Auto-Tuning start display.

- Note:** These instructions continue from Step 6 in "Enter Data from the Motor Nameplate".

Step		Display/Result
1.	After entering the data listed on the motor nameplate, press  to confirm.	<div style="border: 1px solid black; padding: 5px;"> -A.TUNE - DRV Rdy Auto-Tuning ----- 0.00 Hz/ 0.00A Tuning Ready ? Press RUN key ESC FWD </div>
2.	Press  to activate Auto-Tuning. DRV flashes. The drive begins by injecting current into the motor for about 1 min, and then starts to rotate the motor. Note: The first digit on the display indicates which motor is undergoing Auto-Tuning (motor 1 or motor 2). The second digit indicates the type of Auto-Tuning being performed.	<div style="border: 1px solid black; padding: 5px;"> -A.TUNE - DRV Rdy Tune Proceeding ----- X.XX Hz/ X.XXA <<<<< >>>>> FWD </div>
3.	Auto-Tuning finishes in approximately one to two minutes.	<div style="border: 1px solid black; padding: 5px;"> -MODE - DRV ----- End Tune Successful FWD RESET </div>

T1: Parameter Settings during Induction Motor Auto-Tuning

The T1-□□ parameters set the Auto-Tuning input data for induction motor tuning.

- Note:** For motors operating in the field weakening range, first perform the Auto-Tuning with the base data. After Auto-Tuning is complete, change E1-04, Maximum Output Frequency, to the desired value.

T1-00: Motor 1/Motor 2 Selection

Selects the motor to be tuned when motor 1/2 switching is enabled (i.e., a digital input is set for function H1-□□ = 16). This parameter is not displayed if motor 1/2 switching is disabled.

No.	Name	Setting Range	Default
T1-00	Motor 1/Motor 2 Selection	1, 2	1

Setting 1: Motor 1

Auto-Tuning automatically sets parameters E1-□□ and E2-□□ for motor 1.

Setting 2: Motor 2

Auto-Tuning automatically sets parameters E3-□□ and E4-□□ for motor 2. Make sure that motor 2 is connected to the drive for Auto-Tuning.

4.7 Auto-Tuning

■ T1-01: Auto-Tuning Mode Selection

Sets the type of Auto-Tuning to be used. *Refer to Auto-Tuning for Induction Motors on page 135* for details on the different types of Auto-Tuning.

No.	Name	Setting Range	Default
T1-01	Auto-Tuning Mode Selection	2, 3 (V/f, V/f w/PG) 0 to 2, 4 (OLV, CLV) 8, 9 (CLV)	2 (V/f, V/f w/PG) 0 (OLV, CLV)

Setting 0: Rotational Auto-Tuning

Setting 1: Stationary Auto-Tuning 1

Setting 2: Stationary Auto-Tuning for Line-to-Line Resistance

Setting 3: Rotational Auto-Tuning for V/f Control

Setting 4: Stationary Auto-Tuning 2

Setting 8: Inertia Tuning

Setting 9: ASR Gain Auto-Tuning

■ T1-02: Motor Rated Power

Sets the motor rated power according to the motor nameplate value.

No.	Name	Setting Range	Default
T1-02	Motor Rated Power	0.00 to 650.00 kW	Determined by o2-04 and C6-01

■ T1-03: Motor Rated Voltage (T1-01 = 0, 1, 3, 4)

Sets the motor rated voltage according to the motor nameplate value. Enter the voltage base speed here if the motor is operating above base speed.

Enter the voltage needed to operate the motor under no-load conditions at rated speed to T1-03 for better control precision around rated speed when using a vector control mode. The no-load voltage can usually be found in the motor test report available from the manufacturer. If the motor test report is not available, enter approximately 90% of the rated voltage printed on the motor nameplate. This may increase the output current and reduce the overload margin.

No.	Name	Setting Range	Default
T1-03	Motor Rated Voltage	0.0 to 255.5 V <1>	200.0 V <1>

<1> Values shown are specific to 200 V class drives. Double value for 400 V class drives. Multiply value by 2.875 for 600 V class drives.

■ T1-04: Motor Rated Current

Sets the motor rated current according to the motor nameplate value. Set the motor rated current between 50% and 100% of the drive rated current for optimal performance in OLV or CLV. Enter the current at the motor base speed.

No.	Name	Setting Range	Default
T1-04	Motor Rated Current	10 to 200% of drive rated current	o2-04

■ T1-05: Motor Base Frequency (T1-01 = 0, 1, 2, 4)

Sets the motor rated frequency according to the motor nameplate value. If a motor with an extended speed range is used or the motor is used in the field weakening area, enter the maximum frequency to E1-04 (E3-04 for motor 2) after Auto-Tuning is complete.

No.	Name	Setting Range	Default
T1-05	Motor Base Frequency	0.0 to 400.0 Hz	60.0 Hz

■ T1-06: Number of Motor Poles (T1-01 = 0, 1, 3, 4)

Sets the number of motor poles according to the motor nameplate value.

No.	Name	Setting Range	Default
T1-06	Number of Motor Poles	2 to 48	4

■ T1-07: Motor Base Speed (T1-01 = 0, 1, 3, 4)

Sets the motor rated speed according to the motor nameplate value. Enter the speed at base frequency when using a motor with an extended speed range or if using the motor in the field weakening area.

No.	Name	Setting Range	Default
T1-07	Motor Base Speed	0 to 24000 r/min	1750 r/min

■ T1-08: PG Number of Pulses Per Revolution (T1-01 = 0, 1, 4)

Sets the number of pulses from the PG encoder. Set the actual number of pulses for one full motor rotation.

No.	Name	Setting Range	Default
T1-08	PG Number of Pulses Per Revolution	1 to 60000 ppr	1024 ppr

Note: T1-08 will only be displayed in CLV.

■ T1-09: Motor No-Load Current (T1-01 = 1, 4)

Sets the no-load current for the motor. The default setting displayed is no-load current automatically calculated from the output power set in T1-02 and the motor rated current set to T1-04. Enter the data listed on the motor test report. Leave this data at the default setting if the motor test report is not available.

No.	Name	Setting Range	Default
T1-09	Motor No-Load Current	0 A to [T1-04] (Max: 0 to 2999.9)	–

Note: The number of decimal places in the parameter value depends on the drive model and the ND/HD selection in parameter C6-01. This value has two decimal places (0.01 A) if the drive is set for a maximum applicable motor capacity up to and including 11 kW, and one decimal place (0.1 A) if the maximum applicable motor capacity is higher than 11 kW. [Refer to Power Ratings on page 463.](#)

■ T1-10: Motor Rated Slip (T1-01 = 4)

Sets the rated slip for the motor. The default setting displayed is the rated slip for a Yaskawa motor calculated from the output power set in T1-02. Enter the data listed on the motor test report.

No.	Name	Setting Range	Default
T1-10	Motor Rated Slip	0.00 to 20.00 Hz	–

■ T1-11: Motor Iron Loss (T1-01 = 3)

Provides iron loss information to determine the Energy Saving coefficient. T1-11 will first display the value for the motor iron loss that the drive automatically calculated the when motor capacity was entered to T1-02. Enter the motor iron loss value listed to T1-11 if the motor test report is available.

No.	Name	Setting Range	Default
T1-11	Motor Iron Loss	0 to 65535 W	14 W Differs depending on motor code and motor parameter settings.

◆ Parameter Settings during PM Motor Auto-Tuning: T2

Note: PM motor control modes are not available on 600 V class drives, models 5A□□□□.

The T2-□□ parameters are used to set the Auto-Tuning input data for PM motor tuning.

■ T2-01: PM Motor Auto-Tuning Mode Selection

Note:

- Setting 11 is valid in drive software versions S1015 and later.
- Setting 11 is not available in models 4A0930 and 4A1200.

Selects the type of Auto-Tuning to be performed. [Refer to Auto-Tuning for Permanent Magnet Motors on page 136](#) for details on different types of Auto-Tuning.

4.7 Auto-Tuning

No.	Name	Setting Range	Default
T2-01	PM Motor Auto-Tuning Mode Selection	0 to 2 (OLV/PM, AOLV/PM) 0 to 3, 8, 9, 11 (CLV/PM)	0

Setting 0: PM Motor Parameter Settings

Setting 1: PM Stationary Auto-Tuning

Setting 2: PM Stationary Auto-Tuning for Stator Resistance

Setting 3: Z-Pulse Offset Tuning

Setting 8: Inertia Tuning

Setting 9: ASR Gain Auto-Tuning

Setting 11: Back EMF Constant Tuning

Note: For special-purpose motors, Yaskawa recommends performing Back EMF Constant Tuning after performing Stationary Auto-Tuning. Back EMF Constant Tuning rotates the motor to measure the actual induction voltage constants, which allows for more accurate control than Stationary Auto-Tuning alone.

■ T2-02: PM Motor Code Selection

If the drive is operating a Yaskawa PM motor from the SMRA, SSR1, or SST4 series, enter the motor code in T2-02 to automatically set parameters T2-03 through T2-14. If the drive is operating a specialized motor or a motor designed by a manufacturer other than Yaskawa, set T2-02 to FFFF and enter the data from the motor nameplate or the motor test report as prompted.

Only the designated PM motor codes may be entered. The PM motor codes accepted by the drive will differ depending on the selected control mode. [Refer to E5: PM Motor Settings on page 233](#) for motor codes.

No.	Name	Setting Range	Default
T2-02	PM Motor Code Selection	0000 to FFFF	Determined by A1-02 and o2-04

■ T2-03: PM Motor Type

Selects the type of PM motor the drive will operate.

No.	Name	Setting Range	Default
T2-03	PM Motor Type	0, 1	1

Setting 0: IPM motor

Setting 1: SPM motor

■ T2-04: PM Motor Rated Power

Specifies the motor rated power in kilowatts.

No.	Name	Setting Range	Default
T2-04	PM Motor Rated Power	0.00 to 650.00 kW	Determined by o2-04 and C6-01

■ T2-05: PM Motor Rated Voltage

Sets the motor rated voltage.

No.	Name	Setting Range	Default
T2-05	PM Motor Rated Voltage	0.0 to 255.0 V <1>	200.0 V <1>

<1> Values shown are specific to 200 V class drives; double the value for 400 V class drives.

■ T2-06: PM Motor Rated Current

Enter the motor rated current in amps.

No.	Name	Setting Range	Default
T2-06	PM Motor Rated Current	10% to 200% of the drive rated current.	Determined by o2-04

■ T2-07: PM Motor Base Frequency

Enter the motor base frequency in Hz.

Note: T2-07 will be displayed when in OLV/PM.

No.	Name	Setting Range	Default
T2-07	PM Motor Base Frequency	0.0 to 400.0 Hz	87.5 Hz

■ T2-08: Number of PM Motor Poles

Enter the number of motor poles.

No.	Name	Setting Range	Default
T2-08	Number of PM Motor Poles	2 to 48	6

■ T2-09: PM Motor Base Speed

Enter the motor rated speed in r/min.

Note: T2-09 will be displayed when in AOLV/PM and CLV/PM.

No.	Name	Setting Range	Default
T2-09	PM Motor Base Speed	0 to 24000 r/min	1750 r/min

■ T2-10: PM Motor Stator Resistance

Enter the motor stator resistance per motor phase.

No.	Name	Setting Range	Default
T2-10	PM Motor Stator Resistance	0.000 to 65.000 Ω	Determined by T2-02

■ T2-11: PM Motor d-Axis Inductance

Enter the d-Axis inductance per motor phase.

No.	Name	Setting Range	Default
T2-11	PM Motor d-Axis Inductance	0.00 to 600.00 mH	Determined by T2-02

■ T2-12: PM Motor q-Axis Inductance

Enter the q-Axis inductance per motor phase.

No.	Name	Setting Range	Default
T2-12	PM Motor q-Axis Inductance	0.00 to 600.00 mH	Determined by T2-02

■ T2-13: Induced Voltage Constant Unit Selection

Selects the units used for setting the induced voltage coefficient.

No.	Name	Setting Range	Default
T2-13	Induced Voltage Constant Unit Selection	0, 1	1

Setting 0: mV (r/min)

Setting 1: mV (rad/sec)

Note: If T2-13 is set to 0, then the drive will use E5-24 (Motor Induction Voltage Constant 2), and will automatically set E5-09 (Motor Induction Voltage Constant 1) to 0.0. If T2-13 is set to 1, then the drive will use E5-09 and will automatically set E5-25 to 0.0.

■ T2-14: PM Motor Induced Voltage Constant (Ke)

Enter the motor induced voltage constant (Ke).

4.7 Auto-Tuning

No.	Name	Setting Range	Default
T2-14	PM Motor Induced Voltage Constant	0.1 to 2000.0	Determined by T2-02

■ T2-15: Pull-In Current Level for PM Motor Tuning

Sets the amount of pull-in current used to tune the d-Axis and q-Axis inductance. Set as a percentage of the motor rated current.

No.	Name	Setting Range	Default
T2-15	Pull-In Current Level for PM Motor Tuning	0 to 120%	30%

■ T2-16: PG Number of Pulses Per Revolution for PM Motor Tuning

Enter the number of pulses from the PG encoder per motor rotation. Set the actual number of pulses for one full motor rotation.

No.	Name	Setting Range	Default
T2-16	PG Number of Pulses Per Revolution for PM Motor Tuning	0 to 15000 ppr	1024 ppr

■ T2-17: Encoder Z Pulse Offset ($\Delta\theta$)

Sets the amount of compensation or offset in 0.1 degree units to fine-tune the home position. Perform Z Pulse tuning when the amount of offset needed for the Z Pulse is unknown or if the PG encoder is replaced.

No.	Name	Setting Range	Default
T2-17	Encoder Z Pulse Offset	-180.0 to 180.0 deg	0.0 deg

◆ Parameter Settings during Inertia and Speed Control Loop Auto-Tuning: T3

These tuning methods apply a sine wave test signal to the system. The drive estimates the system inertia by the measuring the response and automatically sets the parameters listed in [Table 4.22](#).

Table 4.22 Parameters Adjusted by Inertia and Speed Loop Auto-Tuning

Parameter	Description	T1-01 or T2-01	
		8 Inertia Tuning	9 Speed Control Loop (ASR) Tuning
C5-01	ASR Proportional Gain 1	–	YES
C5-17 (C5-37)	Motor Inertia	YES	YES
C5-18 (C5-38)	Motor Inertia Ratio	YES	YES
L3-24	Motor Acceleration Time for Inertia Calculations	YES	YES
L3-25	Load Inertia Ratio	YES	YES
n5-02	Motor Acceleration Time	YES	YES
n5-03	Feed Forward Control Ratio Gain	YES	YES

■ T3-01: Inertia Tuning Frequency Reference

Sets the frequency of the test signal applied to the motor during Inertia Tuning. Although this setting rarely needs to be changed, increasing the value may be beneficial when working with high inertia loads.

No.	Name	Setting Range	Default
T3-01	Inertia Tuning Frequency Reference	0.1 to 20.0 Hz	3.0 Hz

■ T3-02: Inertia Tuning Reference Amplitude

Enter the amplitude of the test signal applied to the motor during Inertia Tuning. Although this setting rarely needs to be changed, decrease the setting if a large load inertia causes problems during Inertia Tuning. Adjust T3-02 if a fault occurs when T3-01 is set to a low value.

No.	Name	Setting Range	Default
T3-02	Inertia Tuning Reference Amplitude	0.1 to 10.0 rad	0.5 rad

■ T3-03: Motor Inertia

Enter the inertia of the motor. This value is used to determine the load inertia using the test signal response. The default setting is for a Yaskawa standard motor as listed in the motor inertia table.

No.	Name	Setting Range	Default
T3-03	Motor Inertia	0.0001 to 600.00 kgm ²	Determined by o2-04, C6-01, E5-01

Note: Capacities 0.1 to 37 kW are set in units of 0.001 kgm². Capacities 5.5 to 45 kW are set in units of 0.001 kgm². Capacities 55 kW and above are set in units of 0.01 kgm².

■ T3-04: ASR Response Frequency

Sets the response frequency (reciprocal of the step response time constant) of the system or the connected machine. The drive uses this value and the load inertia to fine-tune the speed control loop gain (C5-01, ASR Gain 1). Oscillation may result if the value input here is higher than the actual response frequency of the system.

No.	Name	Setting Range	Default
T3-04	ASR Response Frequency	0.1 to 50.0 Hz	10.0 Hz

4.8 No-Load Operation Test Run

◆ No-Load Operation Test Run

This section explains how to operate the drive with the motor decoupled from the load during a test run.

■ Before Starting the Motor

Check the following items before operation:

- Ensure the area around the motor is safe.
- Ensure external emergency stop circuitry is working properly and other safety precautions have been taken.

■ During Operation

Check the following items during operation:

- The motor should rotate smoothly (i.e., no abnormal noise or oscillation).
- The motor should accelerate and decelerate smoothly.

■ No-Load Operation Instructions

The following example illustrates a test run procedure using the digital operator.

Note: Before starting the motor, set the frequency reference d1-01 to 6 Hz.

Step		Display/Result
1.	Turn on the power to the drive. The initial display appears.	
2.	Press to select LOCAL. The LO/RE light will turn on.	
3.	Press to give the drive a Run command. RUN will light and the motor will rotate at 6 Hz.	
4.	Ensure the motor is rotating in the correct direction and that no faults or alarms occur.	
5.	If there is no error in step 4, press to increase the frequency reference. Increase the frequency in increments of 10 Hz, verifying smooth operation at all speeds. For each frequency, check the drive output current using monitor U1-03. The current should be well below the motor rated current.	—

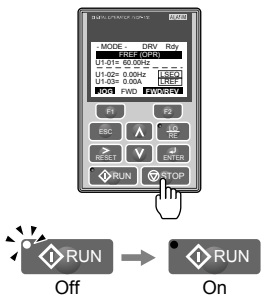
	Step		Display/Result
6.	<p>The drive should operate normally. Press  to stop the motor. RUN flashes until the motor comes to a complete stop.</p>	<p>→</p>	

4.9 Test Run with Load Connected

◆ Test Run with the Load Connected

After performing a no-load test run, connect the motor and proceed to run the motor and load together.

■ Precautions for Connected Machinery

WARNING! *Sudden Movement Hazard. Clear all personnel from the drive, motor, and machine area before applying power. System may start unexpectedly upon application of power, causing death or serious injury.*

WARNING! *Sudden Movement Hazard. Always check the operation of any fast stop circuits after they are wired. Fast stop circuits are required to provide safe and quick shutdown of the drive. Prepare to initiate an emergency stop during the test run. Operating a drive with untested emergency circuits could result in death or serious injury.*

- The motor should come to a complete stop without problems.
- Connect the load and machinery to the motor.
- Fasten all installation screws properly and check that the motor and connected machinery are held in place.

■ Checklist Before Operation

- The motor should rotate in the proper direction.
- The motor should accelerate and decelerate smoothly.

■ Operating the Motor under Loaded Conditions

Test run the application similarly to the no-load test procedure when connecting the machinery to the motor.

- Monitor U1-03 for overcurrent during operation.
- If the application permits running the load in the reverse direction, change the motor direction and the frequency reference while watching for abnormal motor oscillation or vibration.
- Correct any problems that occur with hunting, oscillation, and other control-related issues.

4.10 Verifying Parameter Settings and Backing Up Changes

Use the Verify Menu to check all changes to parameter settings. *Refer to Verifying Parameter Changes: Verify Menu on page 123.*

Save the verified parameter settings. Change the access level or set a password to the drive to prevent accidental modification of parameter settings.

◆ Backing Up Parameter Values: o2-03

Setting o2-03 to 1 saves all parameter settings before resetting o2-03 to 0. The drive can now recall all the saved parameters by performing a User Initialization (A1-03 = 1110).

No.	Parameter Name	Description	Setting Range	Default Setting
o2-03	User Defaults	Lets the user create a set of default settings for a User Initialization. 0: Saved/Not Set 1: Set Defaults - Saves current parameter settings as the default values for a User Initialization. 2: Clear All - Clears the currently saved user settings. After saving the user parameter set value, the items of 1110 (User Initialization) are displayed in A1-03 (User Parameter Default Value).	0 to 2	0
A1-03	Initialize Parameters	Selects a method to initialize the parameters. 0: No Initialize 1110: User Initialization (The user must first program and store desired settings using parameter o2-03) 2220: 2-Wire Initialization (parameter initialized prior to shipment) 3330: 3-Wire Initialization 5550: oPE4 Fault reset	0 to 5550	0

◆ Parameter Access Level: A1-01



Setting the Access Level for “Operation only” (A1-01 = 0) allows the user to access parameters A1-□□ and U□-□□ only. Other parameters are not displayed.

Setting the Access Level for “User Parameters” (A1-01 = 1) allows the user to access only the parameters that have been previously saved as User Parameters. This is helpful when displaying only the relevant parameters for a specific application.

No.	Parameter Name	Description	Setting Range	Default
A1-01	Access Level Selection	Selects which parameters are accessible via the digital operator. 0: Operation only. A1-01, A1-04, and A1-06 can be set and monitored, and U□-□□ parameters can also be viewed. 1: User Parameters. Only recently changed parameters from application parameters A2-01 to A2-16 and A2-17 to A2-32 can be set and monitored. 2: Advanced Access Level. All parameters can be set and monitored.	0 to 2	2
A2-01 to A2-32	User Parameters 1 to 32	Parameters selected by the user are saved as User Parameters, including recently viewed parameters and parameters specifically selected for quick access. If parameter A2-33 is set to 1, recently viewed parameters will be listed between A2-17 and A2-32. Parameters A2-01 through A2-16 must be manually selected by the user. If A2-33 is set to 0, recently viewed parameters will not be saved to the group of User Parameters. A2-□□ parameters are now available for manual programming.	b1-01 to o□-□□	-
A2-33	User Parameter Automatic Selection	0: Parameters A2-01 through A2-32 are reserved for the user to create a group of User Parameters. 1: Save history of recently viewed parameters. Recently edited parameters will be saved to A2-17 through A2-32 for quick access. The most recently changed parameter is saved to A2-17. The second most recently changed parameter is saved to A2-18, etc.	0, 1	1

◆ Password Settings: A1-04, A1-05

The user can set a password in parameter A1-05 to restrict access to the drive. The password must be entered to A1-04 to unlock parameter access (i.e., parameter setting A1-04 must match the value programmed into A1-05). The following parameters cannot be viewed or edited until the value entered to A1-04 correctly matches the value set to A1-05: A1-01, A1-02, A1-03, A1-06, and A2-01 through A2-33.

Note: Parameter A1-05 is hidden from view. To display A1-05, access parameter A1-04 and press  and  simultaneously.

◆ Copy Function

Parameter settings can be copied to another drive to simplify parameter restoration or multiple drive setup. The drive supports the following copy options:

- **LCD Operator (standard in all models)**

The LCD operator used to operate the drive supports copying, importing, and verifying parameter settings. *Refer to o3: Copy Function on page 327* for details.

- **LED Operator**

The optional LED operator also supports copying, importing, and verifying parameter settings. Refer to the manual supplied with the LED operator for instructions.

- **USB Copy Unit and CopyUnitManager**

The copy unit is an external option connected to the drive to copy parameter settings from one drive and save those settings to another drive. Refer to the manual supplied with the USB Copy Unit for instructions.

The CopyUnitManager is a PC software tool. It allows the user to load parameter settings from the Copy Unit onto a PC, or from the PC onto a Copy Unit. This is useful when managing parameters for various drives or applications. Refer to the manual supplied with the CopyUnitManager for instructions.

- **DriveWizard Plus**

DriveWizard Plus is a PC software tool for parameter management, monitoring, and diagnosis. DriveWizard Plus can load, store, and copy drive parameter settings. For details, refer to Help in the DriveWizard Plus software.

4.11 Test Run Checklist

Review the checklist before performing a test run. Check each item that applies.

<input checked="" type="checkbox"/>	No.	Checklist	Page
<input type="checkbox"/>	1	Thoroughly read the manual before performing a test run.	–
<input type="checkbox"/>	2	Turn the power on.	131
<input type="checkbox"/>	3	Set the voltage for the power supply to E1-01.	223
<input type="checkbox"/>	4	Select the correct duty rating (C6-01) for the application.	–

Check the items that correspond to the control mode being used.

WARNING! Sudden Movement Hazard. Ensure start/stop and safety circuits are wired properly and in the correct state before energizing the drive. Failure to comply could result in death or serious injury from moving equipment. When programmed for 3-Wire control, a momentary closure on terminal S1 may cause the drive to start.

<input checked="" type="checkbox"/>	No.	Checklist	Page
V/f Control (A1-02 = 0) and V/f Control with PG (A1-02 = 1)			
<input type="checkbox"/>	5	Select the best V/f pattern according to the application and motor characteristics.	–
<input type="checkbox"/>	6	Perform Rotational Auto-Tuning for V/f Control if using Energy Saving functions.	135
V/f Control with PG (A1-02 = 1)			
<input type="checkbox"/>	7	Set up the PG feedback parameters correctly and make sure the encoder pulse counting direction is correct.	236
<input type="checkbox"/>	8	Set the proportional gain for ASR speed control to C5-01 and the integral time to C5-02.	202
Open Loop Vector Control (A1-02 = 2) or Closed Loop Vector Control (A1-02 = 3)			
<input type="checkbox"/>	9	Decouple motor shafts and machines when performing Rotational Auto-Tuning.	141
<input type="checkbox"/>	10	Set the Auto-Tuning mode to T1-01 (0 for Rotational Auto-Tuning).	141
<input type="checkbox"/>	11	Enter the following data according to the information listed on the motor nameplate: <ul style="list-style-type: none"> • Motor rated power to T1-02 (kW) • Motor rated voltage to T1-03 (V) • Motor rated current to T1-04 (A) • Motor base frequency to T1-05 (Hz) • Number of motor poles to T1-06 • Motor base speed to T1-07 (r/min) 	141
Closed Loop Vector Control (A1-02 = 3)			
<input type="checkbox"/>	12	Set F1-01 and F1-05.	–
<input type="checkbox"/>	13	Set ASR proportional gain to C5-01 and ASR integral time to C5-02. Perform ASR Tuning if possible.	202
Open Loop Vector Control for PM (A1-02 = 5)			
<input type="checkbox"/>	14	Perform Auto-Tuning as described.	143
Advanced Open Loop Vector Control for PM (A1-02 = 6)			
<input type="checkbox"/>	15	Perform Auto-Tuning as described.	143
<input type="checkbox"/>	16	Set the proportional gain for ASR speed control to C5-01 and the integral time to C5-02.	202
Closed Loop Vector Control for PM (A1-02 = 7)			
<input type="checkbox"/>	17	Set PM motor data using E5-□□ parameters.	143
<input type="checkbox"/>	18	Set ASR proportional gain to C5-01 and ASR integral time to C5-02. Perform ASR Tuning if possible.	202
<input type="checkbox"/>	19	Set F1-01 and F1-05.	–
<input type="checkbox"/>	20	Set the offset between the rotor magnetic axis and the Z-pulse of the connected encoder to E5-11.	143
<input type="checkbox"/>	21	The DRV should light after giving a Run command.	–
<input type="checkbox"/>	22	To give Run command and frequency reference from the digital operator, press “LO/RE” key to set to LOCAL.	125
<input type="checkbox"/>	23	If the motor rotates in the opposite direction during test run, switch two of U/T1, V/T2, W/T3, or change b1-14.	131
<input type="checkbox"/>	24	In accordance with load condition, set Heavy Duty or Normal Duty mode using parameter C6-01. Normal Duty is the default setting.	–

4.11 Test Run Checklist

<input checked="" type="checkbox"/>	No.	Checklist	Page
<input type="checkbox"/>	25	Set motor rated current (E2-01, E4-01, E5-03) and motor protection (L1-01) values for motor thermal protection.	–
<input type="checkbox"/>	26	Set the drive for REMOTE when control circuit terminals provide the Run command and frequency reference.	125
<input type="checkbox"/>	27	If the control circuit terminals should supply the frequency reference, select the correct voltage input signal level (0 to 10 V or -10 to +10 V) or the correct current input signal level (4 to 20 mA or 0 to 20 mA).	162
<input type="checkbox"/>	28	Set the proper voltage to terminals A1 and A3 (0 to 10 V or -10 to +10 V).	162
<input type="checkbox"/>	29	Set the proper current to terminal A2. (-10 to +10 V, 4 to 20 mA or 0 to 20 mA).	162
<input type="checkbox"/>	30	When current input is used, switch the built-in DIP switch S1 from the V-side to I-side. Set the level for current signal used to H3-09 (set “2” for 4 to 20 mA, or “3” for 0 to 20 mA).	162
<input type="checkbox"/>	31	Set DIP Switch S1 on the drive to “I” when using terminal A2 as current input. Set DIP Switch S1 on the drive to “V” when using terminal A2 as voltage input.	–
<input type="checkbox"/>	32	If an analog input supplies the frequency reference, make sure it produces the desired frequency reference. Make the following adjustments if the drive does not operate as expected: Gain adjustment: Set the maximum voltage/current signal and adjust the analog input gain (H3-03 for A1, H3-11 for A2, H3-07 for A3) until the frequency reference value reaches the desired value. Bias adjustment: Set the minimum voltage/current signal and adjust the analog input bias (H3-04 for A1, H3-12 for A2, H3-08 for A3) until the frequency reference value reaches the desired minimum value.	–

Parameter Details

5.1	A: INITIALIZATION.....	156
5.2	B: APPLICATION.....	162
5.3	C: TUNING.....	193
5.4	D: REFERENCE SETTINGS.....	208
5.5	E: MOTOR PARAMETERS.....	223
5.6	F: OPTION SETTINGS.....	236
5.7	H: TERMINAL FUNCTIONS.....	247
5.8	L: PROTECTION FUNCTIONS.....	279
5.9	N: SPECIAL ADJUSTMENTS.....	313
5.10	O: OPERATOR RELATED SETTINGS.....	324
5.11	U: MONITOR PARAMETERS.....	331

5.1 A: Initialization

The initialization group contains parameters associated with initial drive setup, including parameters involving the display language, access levels, initialization, and password.

◆ A1: Initialization

■ A1-00: Language Selection

Selects the display language for the digital operator.

Note: This parameter is not reset when the drive is initialized using parameter A1-03.

No.	Parameter Name	Setting Range	Default
A1-00	Language Selection	0 to 7	0

Setting 0: English

Setting 1: Japanese

Setting 2: German

Setting 3: French

Setting 4: Italian

Setting 5: Spanish

Setting 6: Portuguese

Setting 7: Chinese

■ A1-01: Access Level Selection

Allows or restricts access to drive parameters.

No.	Parameter Name	Setting Range	Default
A1-01	Access Level Selection	0 to 2	2

Setting 0: Operation only

Access to only parameters A1-01, A1-04, and all U monitor parameters.

Setting 1: User Parameters

Access to only a specific list of parameters set to A2-01 through A2-32. These User Parameters can be accessed using the Setup Mode of the digital operator.

Setting 2: Advanced Access Level (A) and Setup Access Level (S)

All parameters can be viewed and edited.

Notes on Parameter Access

- If the drive parameters are password protected by A1-04 and A1-05, parameters A1-00 through A1-03, A1-06, and all A2 parameters cannot be modified.
- If a digital input terminal programmed for “Program lockout” (H1-□□ = 1B) is enabled, parameter values cannot be modified, even if A1-01 is set to 1 or 2.
- If parameters are changed via serial communication, it will not be possible to edit or change parameter settings with the digital operator until an Enter command is issued to the drive from the serial communication.

■ A1-02: Control Method Selection

Selects the Control Method (also referred to as the control mode) that the drive uses to operate the motor. Parameter A1-02 determines the control mode for motor 1 when the drive is set up to run two motors.

Note: When changing control modes, all parameter settings depending upon the setting of A1-02 will be reset to the default.

No.	Parameter Name	Setting Range	Default
A1-02	Control Method Selection	0, 1, 2, 3, 5, 6, 7	2

Control Modes for Induction Motors (IM)

Setting 0: V/f Control for Induction Motors

Use this mode for simple speed control and for multiple motor applications with low demands to dynamic response or speed accuracy. This control mode is also used when the motor parameters are unknown and Auto-Tuning cannot be performed. The speed control range is 1:40.

Setting 1: V/f Control with PG Speed Feedback

Use this mode for general-purpose applications that require high speed accuracy but do not require high dynamic response. This control mode is also used when the motor parameters are unknown and Auto-Tuning cannot be performed. The speed control range is 1:40.

Setting 2: Open Loop Vector Control

Use this mode for general, variable-speed applications with a speed control range of 1:200 that require precise speed control, quick torque response, and high torque at low speed without using a speed feedback signal from the motor.

Setting 3: Closed Loop Vector Control

Use this mode for general, variable-speed applications that require precise speed control down to zero speed, quick torque response or precise torque control, and a speed feedback signal from the motor. The speed control range is up to 1:1500.

Control Modes for Permanent Magnet Motors (SPM or IPM)

Note: PM motor control modes are not available on 600 V class drives, models 5A□□□□.

Setting 5: Open Loop Vector Control for PM

Use this mode when running a PM motor in variable torque applications that benefit from energy efficiency. The drive can control an SPM or IPM motor with a speed range of 1:20 in this control mode.

Setting 6: Advanced Open Loop Vector Control for PM

Use this mode to operate an IPM motor for constant torque applications. Set High Frequency Injection parameter n8-57 to 1 to achieve a speed control range as high as 1:100. *Refer to n8-57: High Frequency Injection on page 321* for details.

Setting 7: Closed Loop Vector Control for PM

Use this mode for high-precision control of a PM motor in constant torque or variable torque applications. The speed control range reaches 1:1500. A speed feedback signal is required.

■ A1-03: Initialize Parameters

Resets parameters to default values. After initialization, the setting for A1-03 automatically returns to 0.

No.	Parameter Name	Setting Range	Default
A1-03	Initialize Parameters	0, 1110, 2220, 3330, 5550	0

Setting 1110: User Initialize

Resets parameters to the values selected by the user as User Settings. User Settings are stored when parameter o2-03 is set to "1: Set defaults".

Note: User Initialization resets all parameters to a user-defined set of default values previously saved to the drive. Set parameter o2-03 to 2 to clear the user-defined default values.

Setting 2220: 2-Wire Initialization

Resets parameters to default settings with digital inputs S1 and S2 configured as Forward run and Reverse run, respectively. *Refer to Setting 40, 41: Forward Run, Reverse Run Command for 2-Wire Sequence on page 254* for more information on digital input functions.

5.1 A: Initialization

Setting 3330: 3-Wire Initialization

Resets parameters to default settings with digital inputs S1, S2, and S5 configured as Run, Stop, and Forward/Reverse respectively. *Refer to Setting 0: 3-Wire Sequence on page 248* for more information on digital input functions.

Setting 5550: oPE04 Reset

An oPE04 error appears on the digital operator when a terminal block with settings saved to its built-in memory is installed in a drive that has edited parameters. Set A1-03 to 5550 to use the parameter settings saved to the terminal block memory.

Notes on Parameter Initialization

The parameters shown in *Table 5.1* will not be reset when the drive is initialized by setting A1-03 = 2220 or 3330. Although the control mode in A1-02 is not reset when A1-03 is set to 2220 or 3330, it may change when an application preset is selected.

Table 5.1 Parameters Not Changed by Drive Initialization

No.	Parameter Name
A1-00	Language Selection
A1-02	Control Method Selection
C6-01	Duty Selection
E1-03	V/f Pattern Selection
E5-01	Motor Code Selection (for PM motors)
F6-08	Communication Parameter Reset
L8-35	Installation Selection
o2-04	Drive/kVA Selection

■ A1-04, A1-05: Password and Password Setting

Parameter A1-04 enters the password when the drive is locked; parameter A1-05 is a hidden parameter that sets the password.

No.	Parameter Name	Setting Range	Default
A1-04	Password	0000 to 9999	0000
A1-05	Password Setting		

How to Use the Password

The user can set a password in parameter A1-05 to restrict access to the drive. The password must be entered to A1-04 to unlock parameter access (i.e., parameter setting A1-04 must match the value programmed into A1-05). The following parameters cannot be viewed or edited until the value entered to A1-04 correctly matches the value set to A1-05: A1-01, A1-02, A1-03, A1-06, and A2-01 through A2-33.

The instructions below demonstrate how to set password “1234”. An explanation follows on how to enter that password to unlock the parameters.

Table 5.2 Setting the Password for Parameter Lock

Step	Display/Result
1. Turn on the power to the drive. The initial display appears.	
2. Press or until the Parameter Setting Mode screen appears.	
3. Press to enter the parameter menu tree.	
4. Select the flashing digits by pressing , , or .	











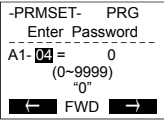

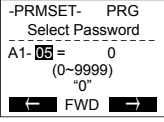

Step		Display/Result
5.	Select A1-04 by pressing  .	
6.	Press  while holding down  at the same time. A1-05 will appear. Note: A1-05 is hidden and will not display by pressing only  .	
7.	Press  .	
8.	Use  ,  ,  ,  and  to enter the password.	
9.	Press  to save what was entered.	
10.	The display automatically returns to the display shown in step 6.	

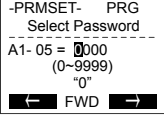
Table 5.3 Check if A1-02 is Locked (continuing from step 10 above)





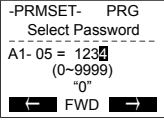

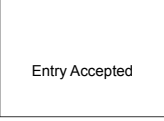
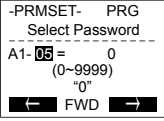



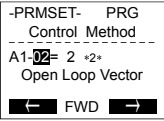

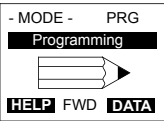

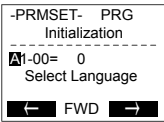

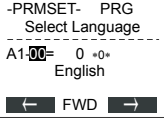

Step		Display/Result
1.	Press  to display A1-02.	
2.	Press  , making sure that the setting values cannot be changed.	
3.	Press  to return to the first display.	

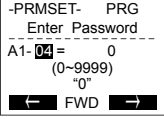
Table 5.4 Enter the Password to Unlock Parameters (continuing from step 3 above)

Step		Display/Result
1.	Press  to enter the parameter setup display.	
2.	Press  ,  ,  to select the flashing digits as shown.	
3.	Press  to scroll to A1-04 and  .	

5.1 A: Initialization

Step			Display/Result
4.	Enter the password "1234".	→	<pre> -PRMSET- PRG Enter Password ----- A1-04= 1234 V/F Control ← FWD → </pre>
5.	Press  to save the new password.	→	<pre> Entry Accepted </pre>
6.	Drive returns to the parameter display.	→	<pre> -PRMSET- PRG Enter Password ----- A1-04= 0 (0-9999) "0" ← FWD → </pre>
7.	Press  and scroll to A1-02.	→	<pre> -PRMSET- PRG Control Method ----- A1-02= 2 *2* Open Loop Vector ← FWD → </pre>
8.	Press  to display the value set to A1-02. If the first "0" blinks, parameter settings are unlocked.	→	<pre> -PRMSET- PRG Control Method ----- A1-02= 2 *2* Open Loop Vector ← FWD → </pre>
9.	Use  and  to change the value if desired (though changing the control mode at this point is not typically done).	→	<pre> -PRMSET- PRG Control Method ----- A1-02= 0 *2* V/F Control "2" ← FWD → </pre>
10.	Press  to save the setting, or press  to return to the previous display without saving changes.	→	<pre> Entry Accepted </pre>
11.	The display automatically returns to the parameter display.	→	<pre> -PRMSET- PRG Control Method ----- A1-02= 0 *0* V/F Control ← FWD → </pre>

- Note:**
1. Parameter settings can be edited after entering the correct password.
 2. Performing a 2-Wire or 3-Wire initialization resets the password to "0000".

■ A1-06: Application Preset

Several Application Presets are available to facilitate drive setup for commonly used applications. Selecting one of these Application Presets automatically assigns functions to the input and output terminals and sets a predefined group of parameters to values appropriate for the selected application.

In addition, the parameters most likely to be changed are assigned to the group of User Parameters, A2-01 through A2-16. User Parameters are part of the Setup Group, which provides quicker access by eliminating the need to scroll through multiple menus.

Refer to Application Selection on page 132 for details on parameter A1-06.

■ A1-07: DriveWorksEZ Function Selection

Enables and disables the DriveWorksEZ program inside the drive.

DriveWorksEZ is a software package for customizing drive functionality or adding PLC functionality by the interconnection and configuration of basic software function blocks. The drive performs user-created programs in 1 ms cycles.

- Note:**
1. If DriveWorksEZ has assigned functions to any of the multi-function output terminals, those functions will remain set to those terminals even after disabling DriveWorksEZ.
 2. For more information on DriveWorksEZ, contact a Yaskawa representative.

No.	Parameter Name	Setting Range	Default
A1-07	DriveWorksEZ Function Selection	0 to 2	0

Setting 0: DWEZ disabled

Setting 1: DWEZ enabled

Setting 2: Digital input

If a digital input is programmed for DWEZ enable/disable (H1-□□ = 9F), DWEZ will be enabled when the input is opened.

◆ A2: User Parameters

■ A2-01 to A2-32: User Parameters 1 to 32

The user can select up to 32 parameters and assign them to parameters A2-01 through A2-32 to provide quicker access by eliminating the need to scroll through multiple menus. The User Parameter list can also save the most recently edited parameters.

No.	Parameter Name	Setting Range	Default
A2-01 to A2-32	User Parameters 1 to 32	b1-01 to o4-13	Determined by A1-06 <I>

<I> A1-06 determines how parameters edited by the user are saved to the list of User Parameters, A2-01 through A2-32. [Refer to Application Selection on page 132](#) for details.

Saving User Parameters

To save specific parameters to A2-01 through A2-32, set parameter A1-01 to 2 to allow access to all parameters, then enter the parameter number to one of the A2-□□ parameters to assign it to the list of User Parameters. Finally, set A1-01 to 1 to restrict access so users can only set and refer to the parameters saved as User Parameters.

■ A2-33: User Parameter Automatic Selection

Determines whether recently edited parameters are saved to the second half of the User Parameters (A2-17 to A2-32) for quicker access.

No.	Parameter Name	Setting Range	Default
A2-33	User Parameter Automatic Selection	0, 1	Determined by A1-06

Setting 0: Do not save list of recently edited parameters

Set A2-33 to 0 to manually select the parameters listed in the User Parameter group.

Setting 1: Save list of recently edited parameters

Set A2-33 to 1 to automatically save recently edited parameters to A2-17 through A2-32. A total of 16 parameters are saved with the most recently edited parameter set to A2-17, the second most recently to A2-18, and so on. Access the User Parameters using the Setup Mode of the digital operator.

5.2 b: Application

◆ b1: Operation Mode Selection

■ b1-01: Frequency Reference Selection 1

Selects the frequency reference source 1 for the REMOTE mode.

- Note:**
1. If a Run command is input to the drive but the frequency reference entered is 0 or below the minimum frequency, the RUN indicator LED on the digital operator will light and the STOP indicator will flash.
 2. Press the LO/RE key to set the drive to LOCAL and use the operator keypad to enter the frequency reference.

No.	Parameter Name	Setting Range	Default
b1-01	Frequency Reference Selection 1	0 to 4	1

Setting 0: Operator keypad

Using this setting, the frequency reference can be input by:

- switching between the multi-speed references in the d1-□□ parameters.
- entering the frequency reference on the operator keypad.

Setting 1: Terminals (analog input terminals)

Using this setting, an analog frequency reference can be entered as a voltage or current signal from terminals A1, A2, or A3.

Voltage Input

Voltage input can be used at any of the three analog input terminals. Make the settings as described in [Table 5.5](#) for the input used.

Table 5.5 Analog Input Settings for Frequency Reference Using Voltage Signals

Terminal	Signal Level	Parameter Settings				Notes
		Signal Level Selection	Function Selection	Gain	Bias	
A1	0 to 10 Vdc	H3-01 = 0	H3-02 = 0 (Frequency Reference Bias)	H3-03	H3-04	-
	-10 to +10 Vdc	H3-01 = 1				
A2	0 to 10 Vdc	H3-09 = 0	H3-10 = 0 (Frequency Reference Bias)	H3-11	H3-12	Set DIP switch S1 on the terminal board to "V" for voltage input.
	-10 to +10 Vdc	H3-09 = 1				
A3	0 to 10 Vdc	H3-05 = 0	H3-06 = 0 (Frequency Reference Bias)	H3-07	H3-08	Set DIP switch S4 on the terminal board to "AI".
	-10 to +10 Vdc	H3-05 = 1				

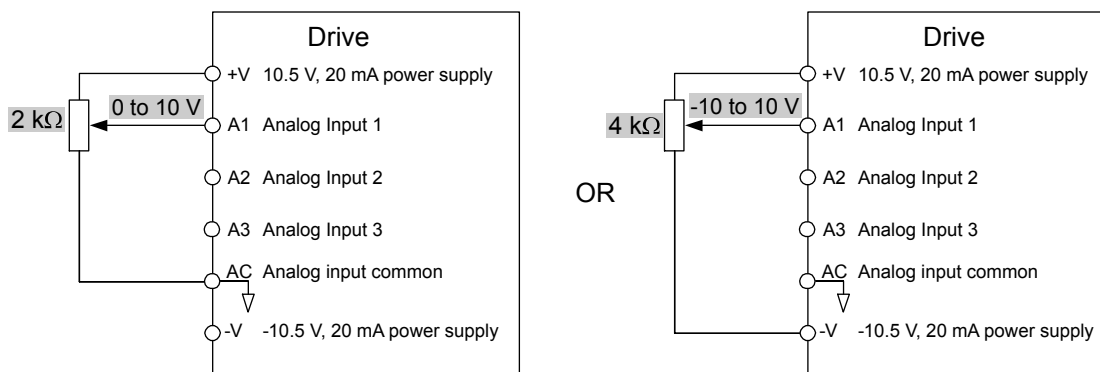

Figure 5.1 Setting the Frequency Reference as a Voltage Signal at Terminal A1

Use the wiring example shown in the figure above for any other analog input terminals. When using input A2 make sure DIP switch S1 is set for voltage input.

Current Input

Input terminal A2 can accept a current input signal. Refer to [Table 5.6](#) to set terminal A2 for current input.

Table 5.6 Analog Input Settings for Frequency Reference Using a Current Signal

Terminal	Signal Level	Parameter Settings				Notes
		Signal Level Selection	Function Selection	Gain	Bias	
A2	4 to 20 mA	H3-09 = 2	H3-10 = 0 (Frequency Bias)	H3-11	H3-12	Make sure to set DIP switch S1 on the terminal board to "I" for current input.
	0 to 20 mA	H3-09 = 3				

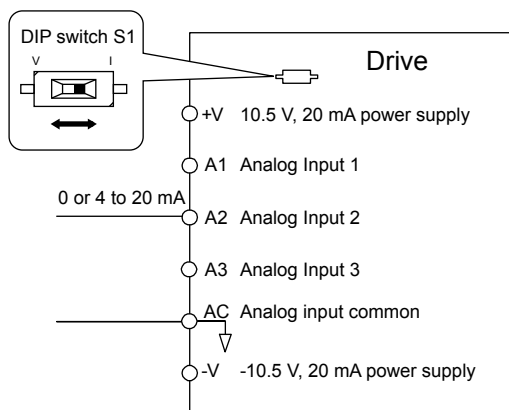

Figure 5.2 Setting the Frequency Reference as a Current Signal to Terminal A2

Switching between Main/Auxiliary Frequency References

The frequency reference input can be switched between the analog terminals A1, A2, and A3 using multi-speed inputs. [Refer to Multi-Step Speed Selection on page 208](#) for details on using this function.

Setting 2: MEMOBUS/Modbus Communications

This setting requires entering the frequency reference via the RS-485/422 serial communications port (control terminals R+, R-, S+, S-). [Refer to MEMOBUS/Modbus Configuration on page 612](#) for instructions.

Setting 3: Option card

This setting requires entering the frequency reference via an option board plugged into connector CN5-A on the drive control board. Consult the option board manual for instructions on integrating the drive with the communication system.

Note: If the frequency reference source is set for Option PCB (b1-01 = 3), but an option board is not installed, an oPE05 Operator Programming Error will be displayed on the digital operator and the drive will not run.

Setting 4: Pulse Train Input

This setting requires a pulse train signal to terminal RP to provide the frequency reference. Follow the directions below to verify that the pulse signal is working properly.

Verifying the Pulse Train is Working Properly

- Set b1-04 to 4 and set H6-01 to 0.
- Set the H6-02 to the pulse train frequency value that equals 100% of the frequency reference.
- Enter a pulse train signal to terminal RP and check for the correct frequency reference on the display.

■ b1-02: Run Command Selection 1

Determines the Run command source 1 in the REMOTE mode.

No.	Parameter Name	Setting Range	Default
b1-02	Run Command Selection 1	0 to 3	1

Setting 0: Operator

This setting requires entering the Run command via the digital operator RUN key and also illuminates the LO/RE indicator on the digital operator.

Setting 1: Control Circuit Terminal

This setting requires entering the Run command via the digital input terminals using one of following sequences:

- 2-Wire sequence 1:

5.2 b: Application

Two inputs (FWD/Stop-REV/Stop). Set A1-03 to 2220 to initialize the drive and preset terminals S1 and S2 to these functions. This is the default setting of the drive. *Refer to Setting 40, 41: Forward Run, Reverse Run Command for 2-Wire Sequence on page 254.*

- 2-Wire sequence 2:

Two inputs (Start/Stop-FWD/REV). *Refer to Setting 42, 43: Run and Direction Command for 2-Wire Sequence 2 on page 255.*

- 3-Wire sequence:

Three inputs (Start-Stop-FWD/REV). Set A1-03 to 3330 to initialize the drive and preset terminals S1, S2, and S5 to these functions. *Refer to Setting 0: 3-Wire Sequence on page 248.*

Setting 2: MEMOBUS/Modbus Communications

This setting requires entering the Run command via serial communications by connecting the RS-485/422 serial communication cable to control terminals R+, R-, S+, and S- on the removable terminal block. *Refer to MEMOBUS/Modbus Configuration on page 612* for instructions.

Setting 3: Option Card

This setting requires entering the Run command via the communication option board by plugging a communication option board into the CN5-A port on the control PCB. Refer to the option board manual for instructions on integrating the drive into the communication system.

Note: If b1-02 is set to 3, but an option board is not installed in CN5-A, an oPE05 operator programming error will be displayed on the digital operator and the drive will not run.

■ b1-03: Stopping Method Selection

Selects how the drive stops the motor when the Run command is removed or when a Stop command is entered.

No.	Parameter Name	Setting Range	Default
b1-03	Stopping Method Selection	0 to 3 <1>	0

<1> The setting range is 0, 1, or 3 in CLV, OLV/PM, AOLV/PM, and CLV/PM.

Setting 0: Ramp to Stop

When the Run command is removed, the drive will decelerate the motor to stop. The deceleration rate is determined by the active deceleration time. The default deceleration time is set to parameter C1-02.

When the output frequency falls below the level set in parameter b2-01, the drive will start DC injection, Zero Speed Control, or Short Circuit Braking, depending on the selected control mode. *Refer to b2-01: DC Injection Braking Start Frequency on page 170* for details.

V/f, V/f w/PG and OLV (A1-02 = 0, 1, 2)

For these control modes, parameter b2-01 sets the starting frequency for DC Injection Braking at Stop. When the output frequency falls below the setting of b2-01, DC Injection Braking is enabled for the time set in parameter b2-04.

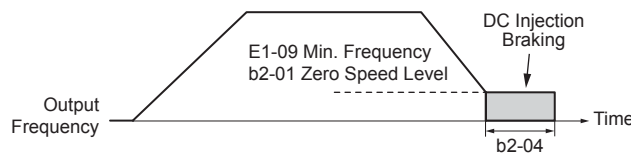

Figure 5.3 DC Injection Braking at Stop for V/f, V/f w/PG, and OLV

Note: If b2-01 is set to a smaller value than E1-09 (Minimum Frequency), then DC Injection Braking will begin when the frequency falls to the E1-09 value.

OLV/PM and AOLV/PM (A1-02 = 5, 6)

Note: PM motor control modes are not available on 600 V class drives, models 5A□□□□.

For these control modes, parameter b2-01 sets the starting frequency for Short-Circuit Braking at Stop. When the output frequency falls below the setting of b2-01, Short-Circuit Braking is enabled for the time set in parameter b2-13.

If DC Injection Braking Time is enabled at stop, then DC Injection Braking is performed for the time set in b2-04 after Short-Circuit Braking is complete.

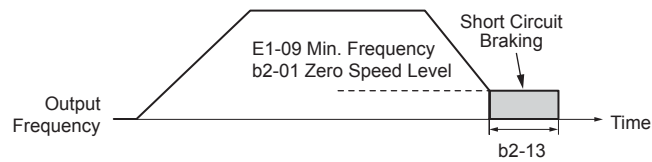

Figure 5.4 Short-Circuit Braking at Stop in OLV/PM and AOLV/PM

Note: If b2-01 is set to a smaller value than E1-09 (Minimum Frequency), then DC Injection Braking will begin when the frequency falls to the E1-09 value.
The drive will not perform short-circuit braking when b2-01 = E1-09 = 0 Hz.

CLV and CLV/PM (A1-02 = 3, 7)

Note: PM motor control modes are not available on 600 V class drives, models 5A□□□□.

For these control modes, parameter b2-01 sets the starting frequency for Zero Speed Control (not position lock) at Stop. When the output frequency falls below the setting of b2-01, Zero Speed Control is enabled for the time set in parameter b2-04.

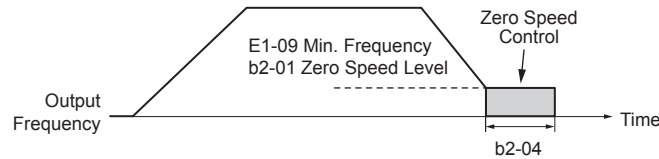

Figure 5.5 Zero Speed Control at Stop in CLV and CLV/PM

Note: If b2-01 is set to lower than E1-09 (Minimum Frequency), then Zero Speed Control begins at the frequency set to E1-09.

Setting 1: Coast to Stop

When the Run command is removed, the drive will shut off its output and the motor will coast (uncontrolled deceleration) to stop. The stopping time is determined by the inertia and the friction in the driven system.

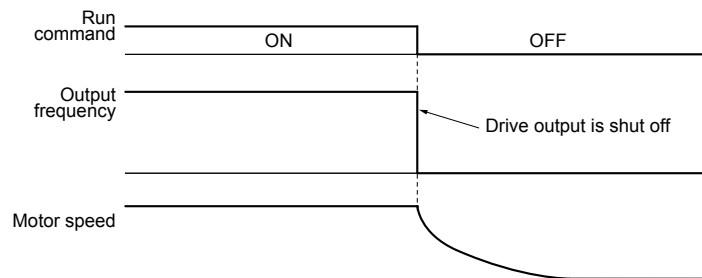

Figure 5.6 Coast to Stop

Note: After a stop is initiated, any subsequent Run command entered will be ignored until the minimum baseblock time (L2-03) has expired. Do not enter Run command until it has come to a complete stop. Use DC Injection at Start ([Refer to b2-03: DC Injection Braking Time at Start on page 171](#)) or Speed Search ([Refer to b3: Speed Search on page 173](#)) to restart the motor before it has completely stopped.

Setting 2: DC Injection Braking to Stop

When the Run command is removed, the drive will enter baseblock (turn off its output) for the minimum baseblock time (L2-03). When the minimum baseblock time has expired, the drive will inject the amount DC Injection Braking is set in parameter b2-02 into the motor windings to brake the motor. The stopping time in DC Injection Braking to Stop is significantly faster compared to Coast to Stop.

Note: This function is not available in CLV or in control modes for PM motors (A1-02 = 5, 6, 7).

5.2 b: Application

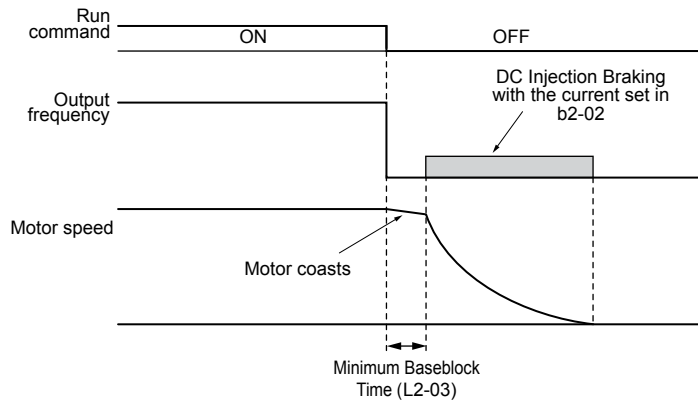

Figure 5.7 DC Injection Braking to Stop

DC Injection Braking time is determined by the value set to b2-04 and the output frequency at the time the Run command is removed. It can be calculated by:

$$\text{DC Injection brake time} = \frac{(\text{b2-04}) \times 10 \times \text{Output frequency}}{\text{Max. output frequency (E1-04)}}$$

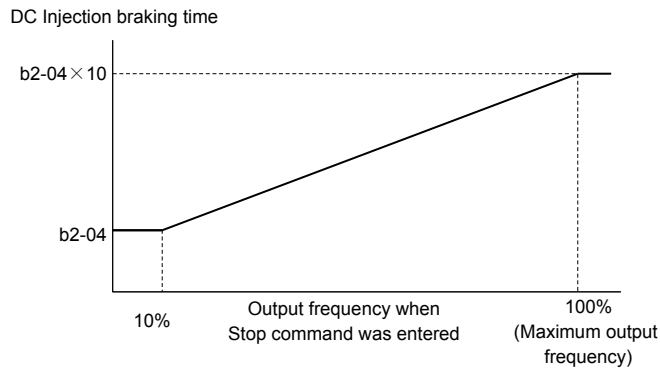

Figure 5.8 DC Injection Braking Time Depending on Output Frequency

Note: If an overcurrent (oC) fault occurs during DC Injection Braking to Stop, lengthen the minimum baseblock time (L2-03) until the fault no longer occurs.

Setting 3: Coast to Stop with Timer

When the Run command is removed, the drive will turn off its output and the motor will coast to stop. The drive will not start if a Run command is input before the time t (C1-02) has expired. Cycle the Run command that was activated during time t after t has expired to start the drive.

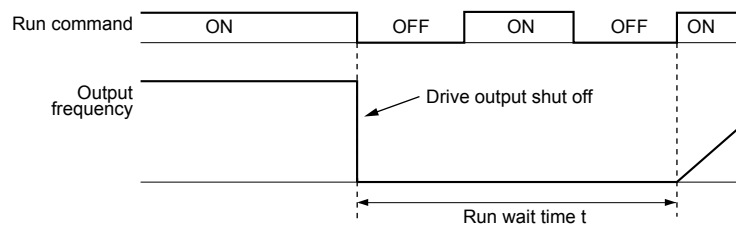

Figure 5.9 Coast to Stop with Timer

The wait time t is determined by the output frequency when the Run command is removed and by the active deceleration time.

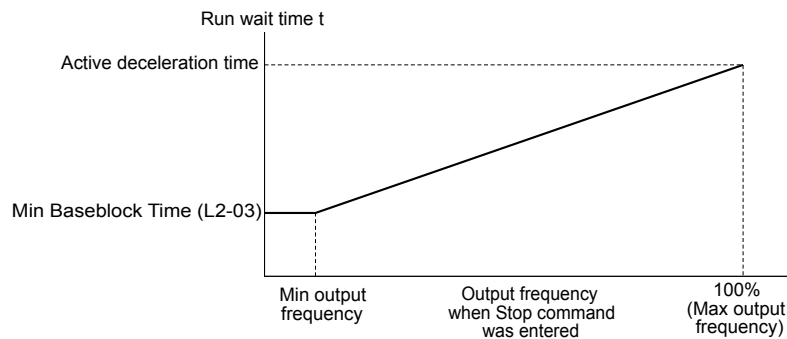

Figure 5.10 Run Wait Time Depending on Output Frequency

■ b1-04: Reverse Operation Selection

Enables and disables Reverse operation. For some applications, reverse motor rotation is not appropriate and may cause problems (e.g., air handling units, pumps, etc.).

No.	Parameter Name	Setting Range	Default
b1-04	Reverse Operation Selection	0, 1	0

Setting 0: Reverse operation enabled

Possible to operate the motor in both forward and reverse directions.

Setting 1: Reverse operation disabled

Drive disregards a Reverse run command or a negative frequency reference.

■ b1-05: Action Selection below Minimum Output Frequency (CLV and CLV/PM)

Note: PM motor control modes are not available on 600 V class drives, models 5A□□□□.

Sets the operation when the frequency reference is lower than the minimum output frequency set in parameter E1-09.

No.	Parameter Name	Setting Range	Default
b1-05	Action Selection below Minimum Output Frequency	0 to 3	0

Setting 0: Follow the Frequency Reference

The drive adjusts the motor speed following the speed reference, even if the frequency reference is below the setting of parameter E1-09. When the Run command is removed and the motor speed is smaller than the setting of b2-01, Zero Speed Control (not position lock) is performed for the time set in parameter b2-04 before the drive output shuts off.

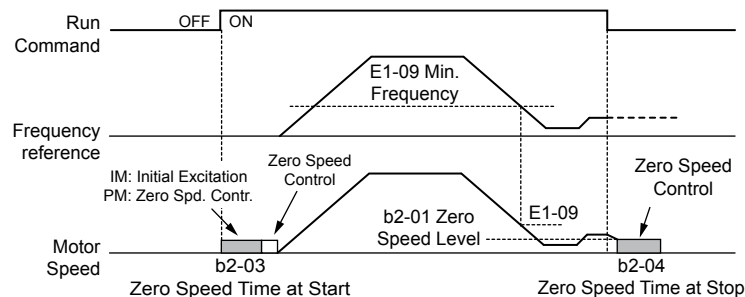

Figure 5.11 Run at the Frequency Reference

Setting 1: Coast to Stop

The motor starts when the frequency reference exceeds the parameter E1-09 setting. When the motor is running and the frequency reference falls below E1-09, the drive output shuts off and the motor coasts. When the motor speed falls below the zero speed level set in b2-01, Zero Speed Control is activated for the time set in b2-04.

5.2 b: Application

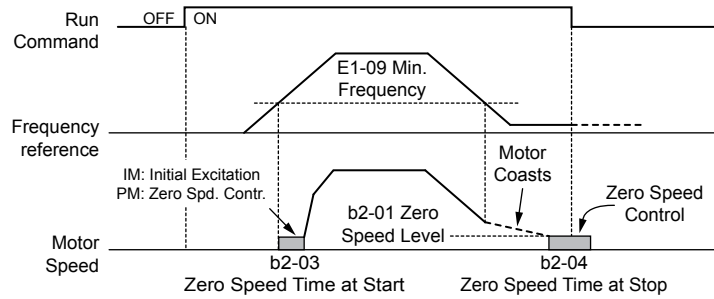

Figure 5.12 Coast to Stop

Setting 2: Run at the minimum frequency

When a Run command is active and the frequency reference is smaller than the parameter E1-09 setting, the drive runs the motor at the speed set in E1-09. When the Run command is removed, the drive decelerates the motor. As soon as the motor speed reaches the zero speed level set in b2-01, Zero Speed Control is activated for the time set in b2-04.

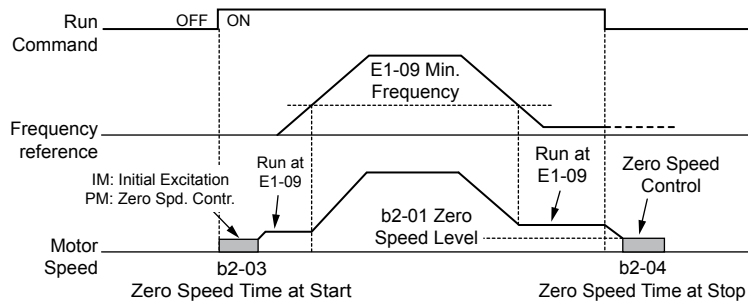

Figure 5.13 Run at the Minimum Frequency

Setting 3: Zero Speed Control

The drive applies Zero Speed Control whenever the frequency reference setting is below the value of parameter E1-09. When the Run command is removed, Zero Speed Control is activated for the time set in b2-04, even if it was already active before.

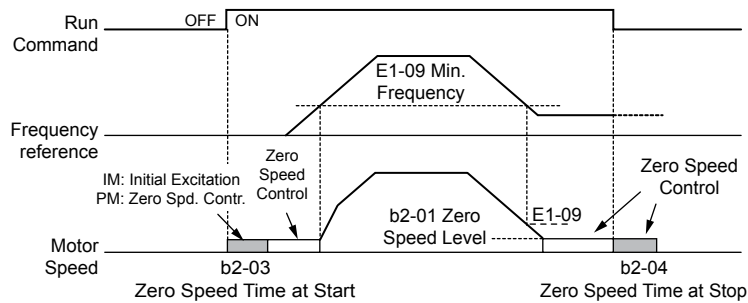

Figure 5.14 Zero Speed Control

■ b1-06: Digital Input Reading

Defines how the digital inputs are read. The inputs are acted upon every 1 ms or 2 ms depending upon the setting.

No.	Name	Setting Range	Default
b1-06	Digital Input Reading	0, 1	1

Setting 0: Read once (1 ms scan)

The state of a digital input is read once. If the state has changed, the input command is immediately processed. With this setting the drive responds more quickly to digital inputs, but a noisy signal could cause erroneous operation.

Setting 1: Read twice (2 ms scan)

The state of a digital input is read twice. The input command is processed only if the state does not change during the double reading. This reading process is slower than the “Read once” process, but it is more resistant to noisy signals.

■ b1-07: LOCAL/REMOTE Run Selection

The drive has three separate control sources that can be switched using digital inputs (H1-□□ = 1 (LOCAL/REMOTE Selection) or 2 (External reference 1/2)) or the LO/RE key on the digital operator. [Refer to Setting 1: LOCAL/REMOTE Selection on page 248](#), [Refer to Setting 2: External Reference 1/2 Selection on page 249](#) and [Refer to o2-01: LO/RE \(LOCAL/REMOTE\) Key Function Selection on page 325](#) for details.

- LOCAL: Digital operator. The digital operator sets the frequency reference and Run command.
- REMOTE: External reference 1. The frequency reference and Run command source are set by b1-01 and b1-02.
- REMOTE: External reference 2. The frequency reference and Run command source are set by b1-15 and b1-16.

When switching from LOCAL to REMOTE, or between External reference 1 and External reference 2, the Run command may already be present at the location at which the source is being switched. In this case, use parameter b1-07 to determine how the Run command is treated.

No.	Parameter Name	Setting Range	Default
b1-07	LOCAL/REMOTE Run Selection	0, 1	0

Setting 0: Run command must be cycled

When the Run command source differs between the old source and the new source (e.g., the old source was the terminals and the new source is serial communication), and the Run command is active at the new source as the switchover occurs, the drive will not start or the drive will stop operation if it was previously running. The Run command must be cycled at the new source to restart the drive.

Setting 1: Accept Run command at the new source

When the Run command is active at the new source, the drive starts or continues operation if it was previously running.

WARNING! Sudden Movement Hazard. The drive may start unexpectedly if switching control sources when b1-07 = 1. Clear all personnel from rotating machinery and electrical connections prior to switching control sources. Failure to comply may cause death or serious injury.

■ b1-08: Run command selection while in Programming Mode

As a safety precaution, the drive will not normally respond to a Run command input when the digital operator is being used to adjust parameters in Programming Mode (Verify Menu, Setup Mode, Parameter Settings Mode, and Auto-Tuning Mode). If required by the application, set b1-08 to allow the drive to run while in Programming Mode.

No.	Parameter Name	Setting Range	Default
b1-08	Run Command Selection while in Programming Mode	0 to 2	0

Setting 0: Disabled

A Run command is not accepted while the digital operator is in Programming Mode.

Setting 1: Enabled

A Run command is accepted in any digital operator mode.

Setting 2: Prohibit programming during run

It is not possible to enter the Programming Mode as long as the drive output is active. The Programming Mode cannot be displayed during Run.

■ b1-14: Phase Order Selection

Sets the phase order for drive output terminals U/T1, V/T2, and W/T3.

Switching motor phases will reverse the direction of the motor.

No.	Parameter Name	Setting Range	Default
b1-14	Phase Order Selection	0, 1	0

Setting 0: Standard Phase Order

Setting 1: Switched Phase Order

■ b1-15: Frequency Reference Selection 2

Enabled when H1-□□ = 2 and the terminal is closed. [Refer to Setting 2: External Reference 1/2 Selection on page 249](#) and [Refer to b1-02: Run Command Selection 1 on page 163](#) for details.

No.	Parameter Name	Setting Range	Default
b1-15	Frequency Reference Selection 2	0 to 4	0

5.2 b: Application

■ b1-16: Run Command Selection 2

Enabled when H1-□□ = 2 and the terminal is closed. *Refer to Setting 2: External Reference 1/2 Selection on page 249* and *Refer to b1-01: Frequency Reference Selection 1 on page 162* for details.

No.	Parameter Name	Setting Range	Default
b1-16	Run Command Selection 2	0 to 3	0

■ b1-17: Run Command at Power Up

Determines whether an external Run command that is active during power up will start the drive.

No.	Parameter Name	Setting Range	Default
b1-17	Run Command at Power Up	0, 1	0

Setting 0: Run Command at Power Up Is Not Issued

Cycle the Run command to start the drive.

Note: For safety reasons, the drive is initially programmed not to accept a Run command at power up (b1-17 = 0). If a Run command is issued at power up, the RUN indicator LED will flash quickly.

Setting 1: Run Command at Power Up Is Issued

If an external Run command is active when the drive is powered up, the drive will begin operating the motor after the internal start up process is complete.

WARNING! *Sudden Movement Hazard. If b1-17 is set to 1 and an external Run command is active during power up, the motor will begin rotating as soon as the power is switched on. Proper precautions must be taken to ensure that the area around the motor is safe prior to powering up the drive. Failure to comply may cause serious injury.*

◆ b2: DC Injection Braking and Short Circuit Braking

These parameters determine operation of the DC Injection Braking, Zero Speed Control, and Short Circuit Braking features.

■ b2-01: DC Injection Braking Start Frequency

Active when “Ramp to Stop” is selected as the stopping method (b1-03 = 0).

No.	Name	Setting Range	Default
b2-01	DC Injection Braking Start Frequency	0.0 to 10.0 Hz	Determined by A1-02

The function triggered by parameter b2-01 depends on the control mode that has been selected.

V/f, V/f w/PG and OLV (A1-02 = 0, 1, 2)

For these control modes, parameter b2-01 sets the starting frequency for DC Injection Braking at Stop. When the output frequency falls below the setting of b2-01, DC Injection Braking is enabled for the time set in parameter b2-04.

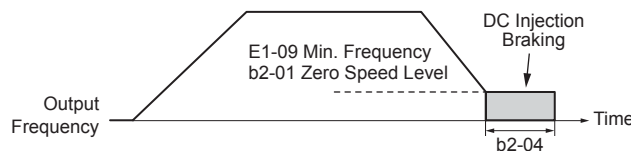

Figure 5.15 DC Injection Braking at Stop for V/f, V/f w/PG, and OLV

Note: If b2-01 is set to a smaller value than E1-09 (Minimum Frequency), then DC Injection Braking will begin when the frequency falls to the E1-09 value.

OLV/PM and AOLV/PM (A1-02 = 5, 6)

Note: PM motor control modes are not available on 600 V class drives, models 5A□□□□.

For these control modes, parameter b2-01 sets the starting frequency for Short-Circuit Braking at Stop. When the output frequency falls below the setting of b2-01, Short-Circuit Braking is enabled for the time set in parameter b2-13.

If DC Injection Braking Time is enabled at stop, then DC Injection Braking is performed for the time set in b2-04 after Short-Circuit Braking is complete.

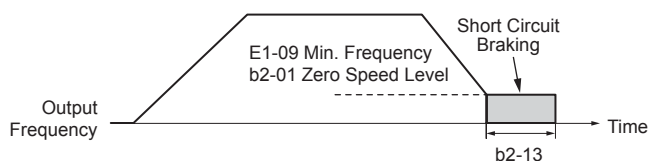

Figure 5.16 Short-Circuit Braking at Stop in OLV/PM and AOLV/PM

Note: If b2-01 is set to a smaller value than E1-09 (Minimum Frequency), then DC Injection Braking will begin when the frequency falls to the E1-09 value. The drive will not perform short-circuit braking when b2-01 = E1-09 = 0 Hz.

CLV and CLV/PM (A1-02 = 3, 7)

Note: PM motor control modes are not available on 600 V class drives, models 5A□□□□□.

For these control modes, parameter b2-01 sets the starting frequency for Zero Speed Control (not position lock) at Stop. When the output frequency falls below the setting of b2-01, Zero Speed Control is enabled for the time set in parameter b2-04.

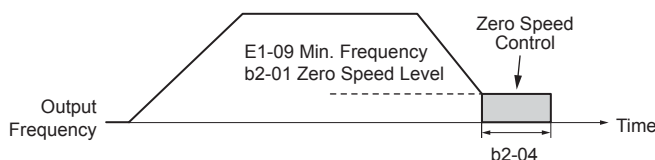

Figure 5.17 Zero Speed Control at Stop in CLV and CLV/PM

Note: If b2-01 is set to lower than E1-09 (Minimum Frequency), then Zero Speed Control begins at the frequency set to E1-09.

■ b2-02: DC Injection Braking Current

Sets the DC Injection Braking current as a percentage of the drive rated current. The carrier frequency is automatically reduced to 1 kHz when this parameter is set to more than 50%.

No.	Name	Setting Range	Default
b2-02	DC Injection Braking Current	0 to 100%	50%

The level of DC Injection Braking current affects the strength of the magnetic field attempting to lock the motor shaft. Increasing the current level will increase the amount of heat generated by the motor windings. Do not set this parameter higher than the level necessary to hold the motor shaft.

■ b2-03: DC Injection Braking Time at Start

Sets the time of DC Injection Braking (Zero Speed Control in CLV and CLV/PM) at start. Used to stop a coasting motor before restarting it or to apply braking torque at start. Disabled when set to 0.00 s.

No.	Name	Setting Range	Default
b2-03	DC Injection Braking Time at Start	0.00 to 10.00 s	0.00 s

Note: Before starting an uncontrolled rotating motor (e.g., a fan motor driven by windmill effect), use DC Injection or Speed Search to stop the motor or detect motor speed before starting it. Otherwise, motor stalling and other faults can occur.

■ b2-04: DC Injection Braking Time at Stop

Sets the time of DC Injection Braking (Zero Speed Control in CLV and CLV/PM) at stop. Used to completely stop a motor with high inertia load after ramp down. Increase the value if the motor still coasts by inertia after it should have stopped. Disabled when set to 0.00 s.

No.	Name	Setting Range	Default
b2-04	DC Injection Braking Time at Stop	0.00 to 10.00 s	Determined by A1-02

5.2 b: Application

■ b2-08: Magnetic Flux Compensation Value

Sets the magnetic flux compensation at start as a percentage of the no-load current value (E2-03). This function allows for the development of more flux to facilitate starting machines that require high starting torque or motors with a large rotor time constant.

No.	Name	Setting Range	Default
b2-08	Magnetic Flux Compensation Value	0 to 1000%	0%

When a Run command is issued, the DC current level injected into the motor changes linearly from the level set to b2-08 to the level set to E2-03 within the time set to b2-03.

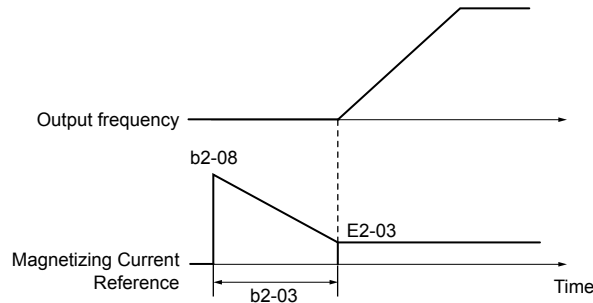

Figure 5.18 Magnetic Flux Compensation

The level of the DC current injected to the motor is limited to 80% of the drive rated current or to the motor rated current, whichever value is smaller.

- Note:**
1. If b2-08 is set below 100%, it can take a relatively long time for flux to develop.
 2. If b2-08 is set to 0%, the DC current level will be the DC Injection current set to b2-02.
 3. As DC Injection can generate a fair amount of noise, b2-08 may need to be adjusted to keep noise levels acceptable.

■ b2-12: Short Circuit Brake Time at Start

Short Circuit Braking can be used in OLV/PM and AOLV/PM. Shorting all three motor phases produces a braking torque in the motor and can stop a coasting motor before starting it again. Disabled when set to 0.00 s.

No.	Name	Setting Range	Default
b2-12	Short Circuit Brake Time at Start	0.00 to 25.50 s	0.00 s

Note: Short Circuit Braking cannot prevent a PM motor from being rotated by an external force. Use DC Injection to prevent the load from rotating the motor.

■ b2-13: Short Circuit Brake Time at Stop

The Short Circuit Braking described for parameter b2-12 can also be applied at the end of deceleration to completely stop high inertia loads. Short Circuit Braking is initiated for the time set in b2-13 when the output frequency falls below the higher of the values b1-02 and E1-09. Disabled when set to 0.00 s.

No.	Name	Setting Range	Default
b2-13	Short Circuit Brake Time at Stop	0.00 to 25.50 s	0.50 s

■ b2-18: Short Circuit Braking Current

Sets the current level for Short Circuit Braking operation as a percentage of the motor rated current. The Short Circuit Braking current cannot be higher than the drive rated current (120% for Normal Duty, 150% for Heavy Duty), although a higher current level can be set using b2-18.

No.	Name	Setting Range	Default
b2-18	Short Circuit Braking Current	0.0 to 200.0%	100.0%

◆ b3: Speed Search

The Speed Search function allows the drive to detect the speed of a rotating motor shaft that is driven by external forces and start the motor operation directly from the detected speed without first stopping the machine.

Example: When a momentary loss of power occurs, the drive output shuts off and the motor coasts. When power returns, the drive can find the speed of the coasting motor and restart it directly.

For PM motors, only parameter b3-01 is needed to enable Speed Search.

For induction motors, the drive offers two types of Speed Search that can be selected by parameter b3-24 (Speed Estimation and Current Detection). Both methods are explained below and followed by a description of all relevant parameters.

■ Current Detection Speed Search (b3-24 = 0)

Current Detection Speed Search detects the motor speed by looking at motor current in IM motors. When Speed Search is started it reduces the output frequency starting from either the maximum output frequency or the frequency reference while increasing the output voltage using the time set in parameter L2-04. As long as the current is higher than the level set to b3-02, the output frequency is lowered using the time constant set to b3-03. If the current falls below b3-02, the drive assumes that the output frequency and motor speed are the same and accelerates or decelerates to the frequency reference.

Be aware that sudden acceleration may occur when using this method of Speed Search with relatively light loads.

Figure 5.19 illustrates Current Detection Speed Search operation after a momentary power loss (L2-01 must be set to 1 or 2):

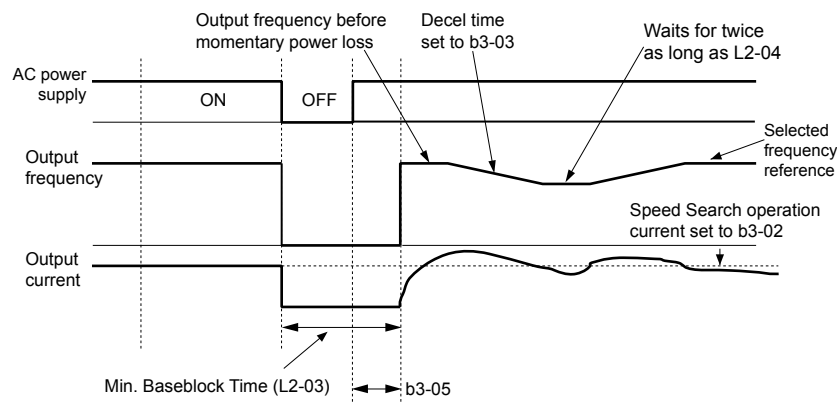

Figure 5.19 Current Detection Speed Search after Power Loss

Note: After power is restored, the drive waits until the time set to b3-05 has passed before performing Speed Search. Thereby the Speed Search may start not at the end of L2-03 but even later.

When Speed Search is applied automatically with the Run command, the drive waits for the minimum baseblock time set to L2-03 before starting Speed Search. If L2-03 is lower than the time set to parameter b3-05, then b3-05 is used as the wait time.

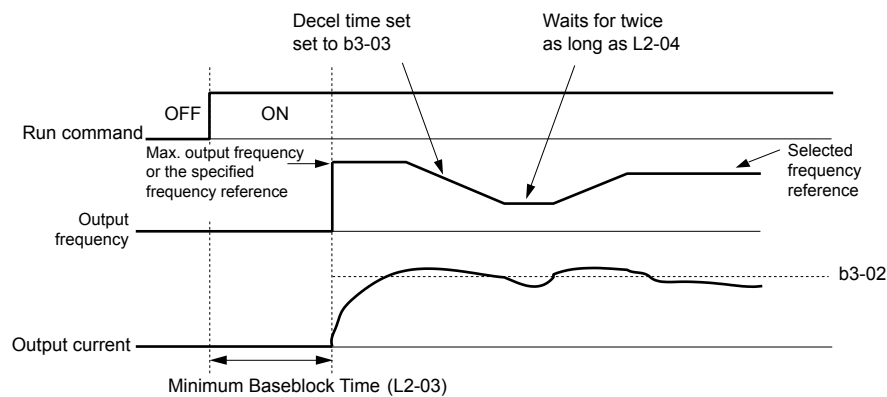

Figure 5.20 Current Detection Speed Search at Start or Speed Search Command by Digital Input

Notes on Using Current Detection Type Speed Search

- Shorten the Speed Search deceleration time set to b3-03 if an oL1 fault occurs while performing Current Detection Speed Search.

5.2 b: Application

- Current Detection Speed Search is not available when using OLV Control for PM motors.
- Increase the minimum baseblock time set to L2-03 if an overcurrent or overvoltage fault occurs when performing Speed Search after power is restored following a momentary power loss.

■ Speed Estimation Type Speed Search (b3-24 = 1)

This method can be used for a single induction motor connected to a drive. Do not use this method if the motor is one or more frame size smaller than the drive, at motor speeds above 200 Hz, or when using a single drive to operate more than one motor.

Speed Estimation is executed in the two steps described below:

Step 1: Back EMF Voltage Estimation

This method is used by Speed Search after baseblock (e.g., a power loss where the drive CPU continued to run and the Run command was kept active). Here, the drive estimates the motor speed by analyzing the back EMF voltage and outputs the estimated frequency and increases the voltage using the time constant set in parameter L2-04. After that, the motor is accelerated or decelerated to the frequency reference starting from the detected speed. If there is not enough residual voltage in the motor windings to perform the calculations described above, the drive will automatically proceed to step 2.

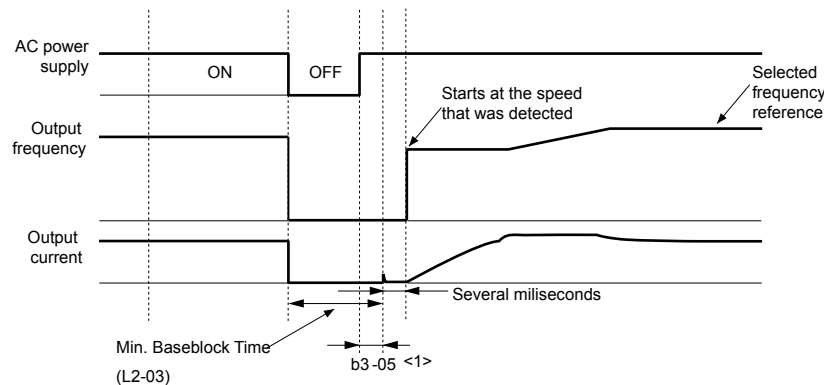

Figure 5.21 Speed Search after Baseblock

<1> After AC power is restored, the drive will wait for at least the time set to b3-05. If the power interruption is longer than the minimum baseblock time set to L2-03, the drive will wait until the time set to b3-05 has passed after power is restored before starting Speed Search.

Step 2: Current Injection

Current Injection is performed when there is insufficient residual voltage in the motor after extended power losses, when Speed Search is applied with the Run command (b3-01 = 1), or when an External search command is used.

This feature injects the amount of DC current set to b3-06 to the motor and detects the speed by measuring the current feedback. The drive then outputs the detected frequency and increases the voltage using the time constant set to parameter L2-04 while looking at the motor current.

The output frequency is reduced if the current is higher than the level in b3-02. When the current falls below b3-02, the motor speed is assumed to be found and the drive starts to accelerate or decelerate to the frequency reference.

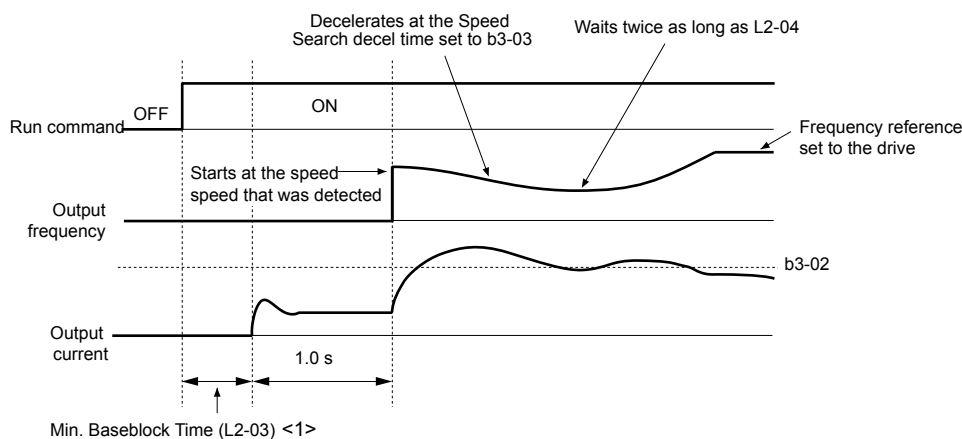

Figure 5.22 Speed Search at Start

<1> The wait time for Speed Search (b3-05) determines the lower limit.

Notes on Using Speed Estimation Speed Search

- Perform Rotational Auto-Tuning for V/f Control (T1-01 = 3) prior to using Speed Estimation in V/f Control and perform Stationary Auto-Tuning for Line-to-Line Resistance (T1-01 = 2) again if there is a change in the cable length between the drive and motor.
- Use Current Detection to search for speeds beyond 200 Hz if the application is running multiple motors from the same drive or if the motor is considerably smaller than the capacity of the drive.
- Speed Estimation may have trouble finding the actual speed if the motor cable is very long. Use Current Detection in these instances.
- Use Current Detection instead of Speed Estimation when operating motors smaller than 1.5 kW because Speed Estimation might not be able to detect the speed or rotation of these smaller motors, in which case Speed Estimation would stop the motor.
- Use Short Circuit Braking instead of Speed Search when using OLV/PM and AOLV/PM with a long motor cable.
- Use Short Circuit Braking instead of Speed Search when attempting to find the speed of a motor coasting faster than 200 Hz in OLV/PM and AOLV/PM.

■ Speed Search Activation

Speed Search can be activated using any of the methods 1 through 5 described below. The Speed Search type must be selected in parameter b3-24 independent of the activation method.

Method 1. Automatically activate Speed Search with every Run command. External Speed Search commands are ignored.

Method 2. Activate Speed Search using the digital input terminals.

Use the input functions for H1-□□ in [Table 5.7](#).

Table 5.7 Speed Search Activation by Digital Inputs

Setting	Description	b3-24 = 0	b3-24 = 1
61	External Search Command 1	Closed: Activate Current Detection Speed Search from the maximum output frequency (E1-04).	Activate Speed Estimation Speed Search
62	External Search Command 2	Closed: Activate Current Detection Speed Search from the frequency reference.	

To activate Speed Search by a digital input, the input must be set together with the Run command or the Run command must be entered after giving the Speed Search command.

Method 3. After automatic fault restart.

When the number of maximum fault restarts in parameter L5-01 is set higher than 0, the drive will automatically perform Speed Search as specified by b3-24 following a fault.

Method 4. After momentary power loss.

This mode requires that the Power Loss Ride-Thru function is enabled during CPU operation (L2-01 = 1 or 2). [Refer to L2-01: Momentary Power Loss Operation Selection on page 286.](#)

Method 5. After external baseblock is released.

5.2 b: Application

The drive will resume the operation starting with Speed Search if the Run command is present and the output frequency is above the minimum frequency when the Baseblock command (H1-□□ = 8 or 9) is released. For this operation mode, set the operation during an external Baseblock command to hold the output frequency (H1-13 = 0).

■ b3-01: Speed Search Selection at Start

Determines if Speed Search is automatically performed when a Run command is issued.

No.	Parameter Name	Setting Range	Default
b3-01	Speed Search Selection at Start	0, 1	Determined by A1-02

Setting 0: Disabled

This setting starts operating the drive at the minimum output frequency when the Run command is entered. If external Speed Search 1 or 2 is already enabled by a digital input, the drive will start operating with Speed Search.

Setting 1: Enabled

This setting performs Speed Search when the Run command is entered. The drive begins running the motor after Speed Search is complete.

■ b3-02: Speed Search Deactivation Current

Sets the operating current for Speed Search as a percentage of the drive rated current. Normally there is no need to change this setting. Lower this value if the drive has trouble restarting.

No.	Name	Setting Range	Default
b3-02	Speed Search Deactivation Current	0 to 200%	Determined by A1-02

Note: When parameter A1-02 = 0 (V/f Control) the factory default setting is 120. When parameter A1-02 = 2 (Open Loop Vector) the factory default setting is 100.

■ b3-03: Speed Search Deceleration Time

Sets the output frequency reduction ramp used by Current Detection Speed Search (b3-24 = 0) and by the Current Injection Method of Speed Estimation (b3-24 = 1). The time entered into b3-03 will be the time to decelerate from maximum frequency (E1-04) to minimum frequency (E1-09).

No.	Name	Setting Range	Default
b3-03	Speed Search Deceleration Time	0.1 to 10.0 s	2.0 s

■ b3-04: V/f Gain During Speed Search

During Speed Search, the output voltage calculated from the V/f pattern is multiplied with this value. Changing this value can help reduce the output current during Speed Search.

No.	Name	Setting Range	Default
b3-04	V/f Gain During Speed Search	10 to 100%	Determined by C6-01 and o2-04

Note: Available control modes for parameter b3-04 vary by drive model:
Models 2A0004 to 2A0415 and 4A0002 to 4A0675: Available when A1-02 = 0.
Models 4A0930 to 4A1200: Available when A1-02 = 0, 2.

■ b3-05: Speed Search Delay Time

In cases where an output contactor is used between the drive and the motor, the contactor must be closed before Speed Search can be performed. This parameter can be used to delay the Speed Search operation, giving the contactor enough time to close completely.

No.	Name	Setting Range	Default
b3-05	Speed Search Delay Time	0.0 to 100.0 s	0.2 s

■ b3-06: Output Current 1 During Speed Search

Sets the current injected to the motor at the beginning of Speed Estimation Speed Search as a factor of the motor rated current set in E2-01 (E4-01 for motor 2). If the motor speed is relatively slow when the drive starts to perform Speed Search after a long period of baseblock, it may be helpful to increase the setting value. The output current during Speed Search is automatically limited by the drive rated current.

No.	Name	Setting Range	Default
b3-06	Output Current 1 during Speed Search	0.0 to 2.0	Determined by o2-04

Note: Use Current Detection Speed Search if Speed Estimation is not working correctly even after adjusting b3-06.

■ b3-07: Output Current 2 during Speed Search (Speed Estimation Type)

Sets the amount of output current during Speed Estimation Speed Search as a coefficient for the no-load current. Output current during Speed Search is automatically limited by the drive rated current. Increase this setting value in increments of 0.1 if the drive fails to perform Speed Estimation

Note: This parameter is only available in models 4A0930 and 4A1200.

No.	Name	Setting Range	Default
b3-07	Output Current 2 during Speed Search (Speed Estimation Type)	0.0 to 5.0	Determined by C6-01 and o2-04

■ b3-08: Current Control Gain during Speed Search (Speed Estimation Type)

Sets the proportional gain for the current controller during Speed Search.

Note: This parameter is only available in models 4A0930 and 4A1200.

No.	Name	Setting Range	Default
b3-08	Current Control Gain during Speed Search (Speed Estimation Type)	0.00 to 6.00	Determined by A1-02

■ b3-10: Speed Search Detection Compensation Gain

Sets the gain for the detected motor speed of the Speed Estimation Speed Search. Increase the setting only if an overvoltage fault occurs when the drive restarts the motor.

No.	Name	Setting Range	Default
b3-10	Speed Search Detection Compensation Gain	1.00 to 1.20	1.05

■ b3-12: Minimum Current Detection Level during Speed Search

Sets the minimum current detection level during Speed Search. Increase this setting value in increments of 0.1 if the drive fails to perform Speed Estimation.

Note: This parameter is only available in models 4A0930 and 4A1200.

No.	Name	Setting Range	Default
b3-12	Minimum Current Detection Level during Speed Search	2.0 to 10.0	6.0

■ b3-14: Bi-Directional Speed Search Selection

Sets how the drive determines the motor rotation direction when performing Speed Estimation Speed Search.

No.	Parameter Name	Setting Range	Default
b3-14	Bi-Directional Speed Search Selection	0, 1	Determined by A1-02

Setting 0: Disabled

The drive uses the frequency reference to determine the direction of motor rotation to restart the motor.

Setting 1: Enabled

The drive detects the motor rotation direction to restart the motor.

■ b3-17: Speed Search Restart Current Level

Sets the current level at which Speed Estimation is restarted as a percentage of drive rated current to avoid overcurrent and overvoltage problems since a large current can flow into the drive if the difference between the estimated frequency and the actual motor speed is too big when performing Speed Estimation.

No.	Name	Setting Range	Default
b3-17	Speed Search Restart Current Level	0 to 200%	150%

5.2 b: Application

■ b3-18: Speed Search Restart Detection Time

Sets the time for which the current must be above the level set in b3-17 before restarting Speed Search.

No.	Name	Setting Range	Default
b3-18	Speed Search Restart Detection Time	0.00 to 1.00 s	0.10 s

■ b3-19: Number of Speed Search Restarts

Sets the number of times the drive should attempt to find the speed and restart the motor. If the number of restart attempts exceeds the value set to b3-19, the SER fault will occur and the drive will stop.

No.	Name	Setting Range	Default
b3-19	Number of Speed Search Restarts	0 to 10	3

■ b3-24: Speed Search Method Selection

Sets the Speed Search method used.

No.	Parameter Name	Setting Range	Default
b3-24	Speed Search Method Selection	0, 1	0

Setting 0: Current Detection Speed Search

Setting 1: Speed Estimation Speed Search

Note: Refer to *Current Detection Speed Search (b3-24 = 0)* on page 173 and *Speed Estimation Type Speed Search (b3-24 = 1)* on page 174 for explanations of the Speed Search methods.

■ b3-25: Speed Search Wait Time

Sets the wait time between Speed Search restarts. Increase the wait time if problems occur with overcurrent, overvoltage, or if the SER fault occurs.

No.	Name	Setting Range	Default
b3-25	Speed Search Wait Time	0.0 to 30.0 s	0.5 s

■ b3-26: Direction Determining Level

Sets the level that determines the direction of motor rotation. Increase this value if the drive fails to detect the direction of the motor correctly.

Note: This parameter is only available in models 4A0930 and 4A1200.

No.	Name	Setting Range	Default
b3-26	Direction Determining Level	40 to 60000	Determined by C6-01 and o2-04

■ b3-27: Start Speed Search Select

Selects a condition to activate Speed Search Selection at Start (b3-01) or External Speed Search Command 1 or 2 from the multi-function input.

No.	Name	Setting Range	Default
b3-27	Start Speed Search Select	0, 1	0

Setting 0: Triggered when a Run Command Is Issued (Normal)

Setting 1: Triggered when an External Baseblock Is Released

◆ b4: Delay Timers

The timer function is independent of drive operation and can delay the switching of a digital output triggered by a digital input signal and help eliminate chattering switch noise from sensors. An on-delay and off-delay can be set separately.

To enable the timer function, set a multi-function input to “Timer input” (H1-□□ = 18) and set a multi-function output to “Timer output” (H2-□□ = 12). Only one timer can be used.

■ b4-01, b4-02: Timer Function On-Delay, Off-Delay Time

b4-01 sets the on-delay time for switching the timer output. b4-02 sets the off-delay time for switching the timer output.

No.	Name	Setting Range	Default
b4-01	Timer Function On-Delay Time	0.0 to 3000.0 s	0.0 s
b4-02	Timer Function Off-Delay Time	0.0 to 3000.0 s	0.0 s

■ Timer Function Operation

The timer function switches on when the timer function input closes for longer than the value set to b4-01. The timer function switches off when the timer function input is open for longer than the value set to b4-02. *Figure 5.23* illustrates the timer function operation:

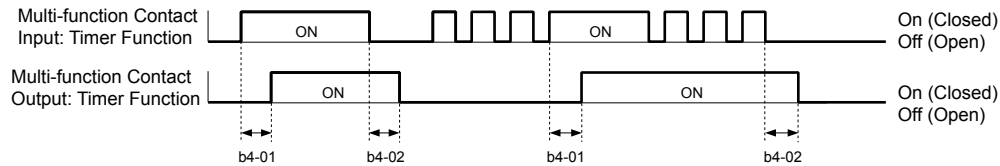

Figure 5.23 Timer Operation

◆ b5: PID Control

The drive has a built-in Proportional + Integral + Derivative (PID) controller that uses the difference between the target value and the feedback value to adjust the drive output frequency to minimize deviation and provide accurate closed loop control of system variables such as pressure or temperature.

■ P Control

The output of P control is the product of the deviation and the P gain so that it follows the deviation directly and linearly. With P control, only an offset between the target and feedback remains.

■ I Control

The output of I control is the integral of the deviation. It minimizes the offset between target and feedback value that typically remains when pure P control is used. The integral time (I time) constant determines how fast the offset is eliminated.

■ D Control

D control predicts the deviation signal by multiplying its derivative (slope of the deviation) with a time constant, then adds this value to the PID input. This way the D portion of a PID controller provides a braking action to the controller response and can reduce the tendency to oscillate and overshoot.

D control tends to amplify noise on the deviation signal, which can result in control instability. Only use D control when absolutely necessary.

■ PID Operation

To better demonstrate PID functionality, *Figure 5.24* illustrates how the PID output changes when the PID input (deviation) jumps from 0 to a constant level.

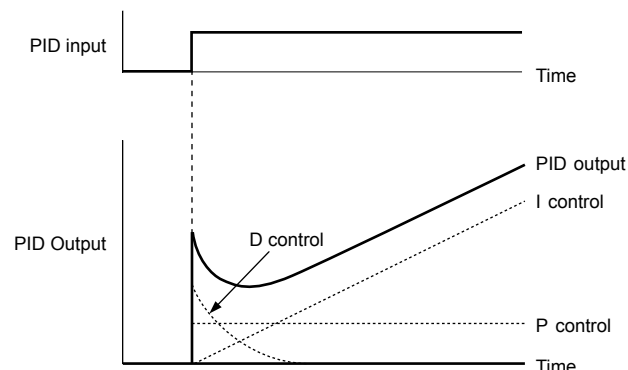

Figure 5.24 PID Operation

5.2 b: Application

■ Using PID Control

Applications for PID control are listed in [Table 5.8](#).

Table 5.8 Using PID Control

Application	Description	Sensors Used
Speed Control	Machinery speed is fed back and adjusted to meet the target value. Synchronous control is performed using speed data from other machinery as the target value	Tachometer
Pressure	Maintains constant pressure using pressure feedback.	Pressure sensor
Fluid Control	Keeps flow at a constant level by feeding back flow data.	Flow rate sensor
Temperature Control	Maintains a constant temperature by controlling a fan with a thermostat.	Thermocoupler, Thermistor

■ PID Setpoint Input Methods

The PID setpoint input depends on the PID function setting in parameter b5-01.

If parameter b5-01 is set to 1 or 2, the frequency reference in b1-01 (or b1-15) or one of the inputs listed in [Table 5.9](#) becomes the PID setpoint.

If b5-01 is set to 3 or 4, then the PID setpoint can be input from one of the sources listed in [Table 5.9](#).

Table 5.9 PID Setpoint Sources

PID Setpoint Source	Settings
Analog Input A1	Set H3-02 = C
Analog Input A2	Set H3-10 = C
Analog Input A3	Set H3-06 = C
MEMOBUS/Modbus Register 0006 H	Set bit 1 in register 000F H to 1 and input the setpoint to register 0006 H
Pulse Input RP	Set H6-01 = 2
Parameter b5-19	Set parameter b5-18 = 1 and input the PID setpoint to b5-19

Note: A duplicate allocation of the PID setpoint input will cause an oPE alarm.

■ PID Feedback Input Methods

Input one feedback signal for normal PID control or input two feedback signals can for controlling a differential process value.

Normal PID Feedback

Input the PID feedback signal from one of the sources listed in [Table 5.10](#):

Table 5.10 PID Feedback Sources

PID Feedback Source	Settings
Analog Input A1	Set H3-02 = B
Analog Input A2	Set H3-10 = B
Analog Input A3	Set H3-06 = B
Pulse Input RP	Set H6-01 = 1

Note: A duplicate allocation of the PID feedback input will cause an oPE alarm.

Differential Feedback

The second PID feedback signal for differential feedback can come from the sources listed in [Table 5.11](#). The differential feedback function is automatically enabled when a differential feedback input is assigned.

Table 5.11 PID Differential Feedback Sources

PID Differential Feedback Source	Settings
Analog Input A1	Set H3-02 = 16
Analog Input A2	Set H3-10 = 16
Analog Input A3	Set H3-06 = 16

Note: A duplicate allocation of the PID differential feedback input will cause an oPE alarm.

■ PID Block Diagram

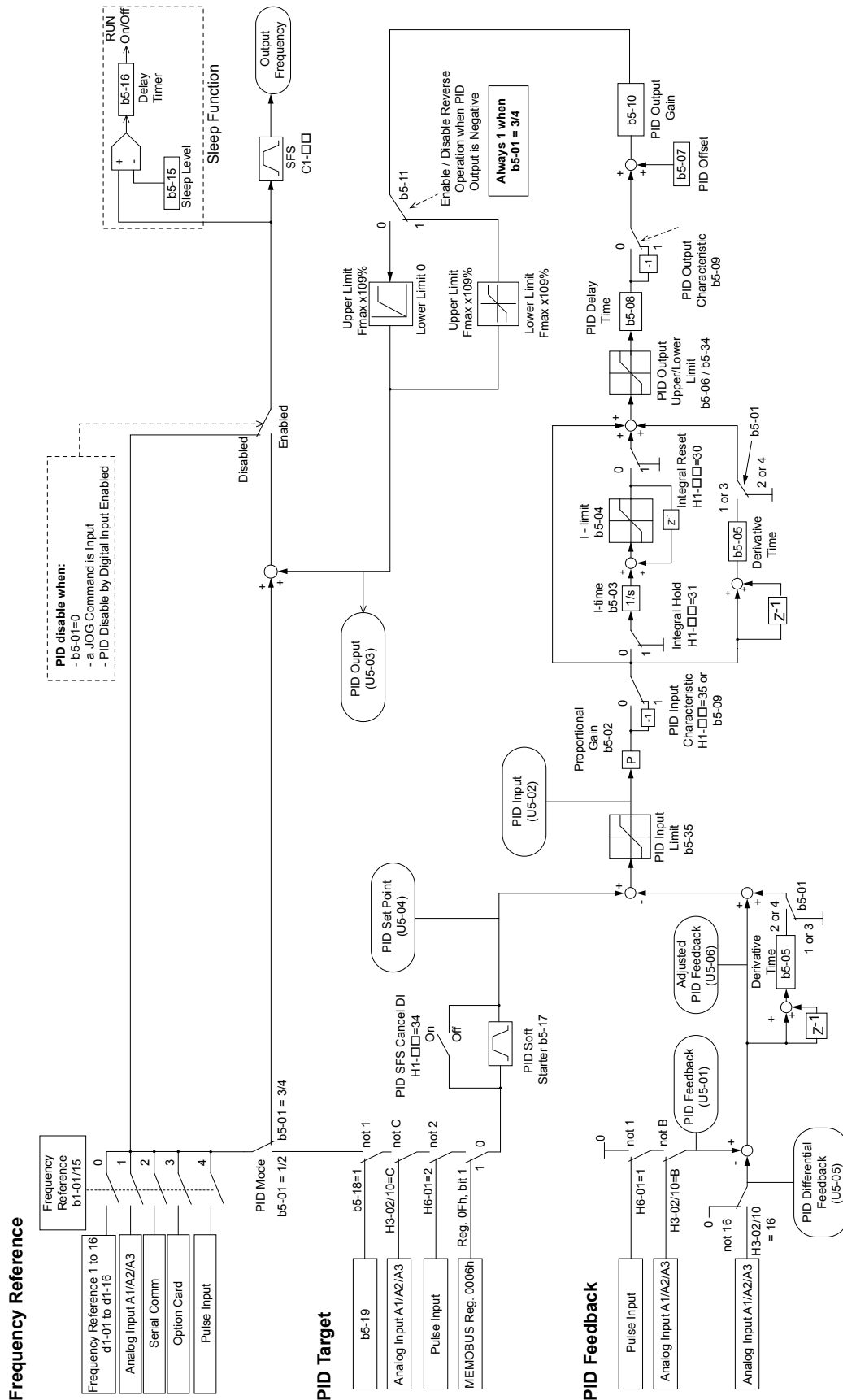

Figure 5.25 PID Block Diagram

5.2 b: Application

■ b5-01: PID Function Setting

Enables or disables the PID operation and selects the PID operation mode.

No.	Parameter Name	Setting Range	Default
b5-01	PID Function Setting	0 to 4	0

Setting 0: PID disabled

Setting 1: Output frequency = PID output 1

The PID controller is enabled and the PID output builds the frequency reference. The PID input is D controlled.

Setting 2: Output frequency = PID output 2

The PID controller is enabled and the PID output builds the frequency reference. The PID feedback is D controlled.

Setting 3: Output frequency = frequency reference + PID output 1

The PID controller is enabled and the PID output is added to the frequency reference. The PID input is D controlled.

Setting 4: Output frequency = frequency reference + PID output 2

The PID controller is enabled and the PID output is added to the frequency reference. The PID feedback is D controlled.

■ b5-02: Proportional Gain Setting (P)

Sets the P gain applied to the PID input. Larger values will tend to reduce the error but may cause oscillations if set too high, while lower values may allow too much offset between the setpoint and feedback.

No.	Name	Setting Range	Default
b5-02	Proportional Gain Setting (P)	0.00 to 25.00	1.00

■ b5-03: Integral Time Setting (I)

Sets the time constant used to calculate the integral of the PID input. The shorter the integral time set to b5-03, the faster the offset will be eliminated. If the integral time is set too short, however, overshoot or oscillation may occur. To turn off the integral time, set b5-03 to 0.00.

No.	Name	Setting Range	Default
b5-03	Integral Time Setting (I)	0.0 to 360.0 s	1.0 s

■ b5-04: Integral Limit Setting

Sets the maximum output possible from the integral block as a percentage of the maximum frequency (E1-04).

No.	Name	Setting Range	Default
b5-04	Integral Limit Setting	0.0 to 100.0%	100.0%

Note: On some applications, especially those with rapidly varying loads, the output of the PID function may show a fair amount of oscillation. Program b5-04 to apply a limit to the integral output and suppress this oscillation.

■ b5-05: Derivative Time (D)

Sets the time the drive predicts the PID input/PID feedback signal based on the derivative of the PID input/PID feedback. Longer time settings improve the response but can cause vibrations, while shorter time settings reduce the overshoot but reduce controller responsiveness. D control is disabled by setting b5-05 to zero seconds.

No.	Name	Setting Range	Default
b5-05	Derivative Time (D)	0.00 to 10.00 s	0.00 s

■ b5-06: PID Output Limit

Sets the maximum output possible from the entire PID controller as a percentage of the maximum frequency (E1-04).

No.	Name	Setting Range	Default
b5-06	PID Output Limit	0.0 to 100.0%	100.0%

■ b5-07: PID Offset Adjustment

Sets the offset added to the PID controller output as a percentage of the maximum frequency (E1-04).

No.	Name	Setting Range	Default
b5-07	PID Offset Adjustment	-100.0 to 100.0%	0.0%

■ b5-08: PID Primary Delay Time Constant

Sets the time constant for the filter applied to the output of the PID controller. Normally, change is not required.

No.	Name	Setting Range	Default
b5-08	PID Primary Delay Time Constant	0.00 to 10.00 s	0.00 s

Note: Useful when there is a fair amount of oscillation or when rigidity is low. Set to a value larger than the cycle of the resonant frequency. Increasing this time constant may reduce the responsiveness of the drive.

■ b5-09: PID Output Level Selection

Reverses the sign of the PID controller output signal. Normally a positive PID input (feedback smaller than setpoint) leads to positive PID output.

No.	Parameter Name	Setting Range	Default
b5-09	PID Output Level Selection	0, 1	0

Setting 0: Normal Output

A positive PID input causes an increase in the PID output (direct acting).

Setting 1: Reverse Output

A positive PID input causes a decrease in the PID output (reverse acting).

■ b5-10: PID Output Gain Setting

Applies a gain to the PID output and can be helpful when the PID function is used to trim the frequency reference (b5-01 = 3 or 4).

No.	Name	Setting Range	Default
b5-10	PID Output Gain Setting	0.00 to 25.00	1.00

■ b5-11: PID Output Reverse Selection

Determines whether a negative PID output reverses the direction of drive operation. This parameter has no effect when the PID function trims the frequency reference (b5-01 = 3 or 4) and the PID output will not be limited (same as b5-11 = 1).

No.	Parameter Name	Setting Range	Default
b5-11	PID Output Reverse Selection	0, 1	0

Setting 0: Reverse Disabled

Negative PID output will be limited to 0 and the drive output will be stopped.

Setting 1: Reverse Enabled

Negative PID output will cause the drive to run in the opposite direction.

■ PID Feedback Loss Detection

The PID feedback loss detection function detects broken sensors or broken sensor wiring. It should be used when PID control is enabled to prevent critical machine conditions (e.g., acceleration to max. frequency) caused by a feedback loss.

Feedback loss can be detected in two ways:

- **Feedback Low Detection**

Detected when the feedback falls below a certain level for longer than the specified time. This function is set up using parameters b5-12 to b5-14.

- **Feedback High Detection**

Detected when the feedback rises above a certain level for longer than the specified time. This function is set up using parameters b5-12, b5-36, and b5-37.

5.2 b: Application

The following figure illustrates the working principle of feedback loss detection when the feedback signal is too low. Feedback high detection works in the same way.

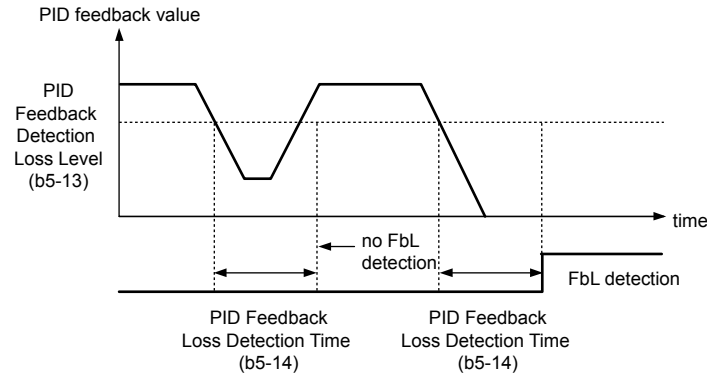

Figure 5.26 PID Feedback Loss Detection

■ b5-12: PID Feedback Loss Detection Selection

Enables or disables the feedback loss detection and sets the operation when a feedback loss is detected.

No.	Parameter Name	Setting Range	Default
b5-12	PID Feedback Loss Detection Selection	0 to 5	0

Setting 0: Digital Output Only

A digital output set for “PID feedback low” (H2-□□ = 3E) will be triggered if the PID feedback value is below the detection level set to b5-13 for the time set to b5-14 or longer. A digital output set for “PID feedback high” (H2-□□ = 3F) will be triggered if the PID feedback value is beyond the detection level set to b5-36 for longer than the time set to b5-37. Neither a fault nor an alarm is displayed on the digital operator and the drive will continue operation. The output resets when the feedback value leaves the loss detection range.

Setting 1: Feedback Loss Alarm

If the PID feedback value falls below the level set to b5-13 for longer than the time set to b5-14, a “FbL - Feedback Low” alarm will be displayed and a digital output set for “PID feedback low” (H2-□□ = 3E) will be triggered. If the PID feedback value exceeds the level set to b5-36 for longer than the time set to b5-37, a “FbH - Feedback High” alarm will be displayed and a digital output set for “PID feedback high” (H2-□□ = 3F) will be triggered. Both events trigger an alarm output (H1-□□ = 10). The drive will continue operation. The alarm and outputs reset when the feedback value leaves the loss detection range.

Setting 2: Feedback Loss Fault

If the PID feedback value falls below the level set to b5-13 for longer than the time set to b5-14, a “FbL - Feedback Low” fault will be displayed. If the PID feedback value exceeds the level set to b5-36 for longer than the time set to b5-37, a “FbH - Feedback High” fault will be displayed. Both events trigger a fault output (H1-□□ = E) and cause the drive to stop the motor.

Setting 3: Digital output only, even if PID is disabled by digital input

Same as b5-12 = 0. Detection remains active when PID is disabled by a digital input (H1-□□ = 19).

Setting 4: Feedback loss alarm, even if PID is disabled by digital input

Same as b5-12 = 1. Detection remains active when PID is disabled by a digital input (H1-□□ = 19).

Setting 5: Feedback loss fault, even if PID is disabled by digital input

Same as b5-12 = 2. Detection remains active when PID is disabled by a digital input (H1-□□ = 19).

■ b5-13: PID Feedback Low Detection Level

Sets the feedback level used for PID feedback low detection. The PID feedback must fall below this level for longer than the time set to b5-14 before feedback loss is detected.

No.	Name	Setting Range	Default
b5-13	PID Feedback Low Detection Level	0 to 100%	0%

■ b5-14: PID Feedback Low Detection Time

Sets the time that the PID feedback has to fall below b5-13 before feedback loss is detected.

No.	Name	Setting Range	Default
b5-14	PID Feedback Low Detection Time	0.0 to 25.5 s	1.0 s

■ b5-36: PID Feedback High Detection Level

Sets the feedback level used for PID feedback high detection. The PID feedback must exceed this level for longer than the time set to b5-37 before feedback loss is detected.

No.	Name	Setting Range	Default
b5-36	PID Feedback High Detection Level	0 to 100%	100%

■ b5-37: PID Feedback High Detection Time

Sets the time that the PID feedback must exceed the value set to b5-36 before feedback loss is detected.

No.	Name	Setting Range	Default
b5-37	PID Feedback High Detection Time	0.0 to 25.5 s	1.0 s

■ PID Sleep

The PID Sleep function stops the drive when the PID output or the frequency reference falls below the PID Sleep operation level for a certain time. The drive will resume operating when the PID output or frequency reference rise above the PID Sleep operation level for the specified time. An example of PID Sleep operation appears in the figure below.

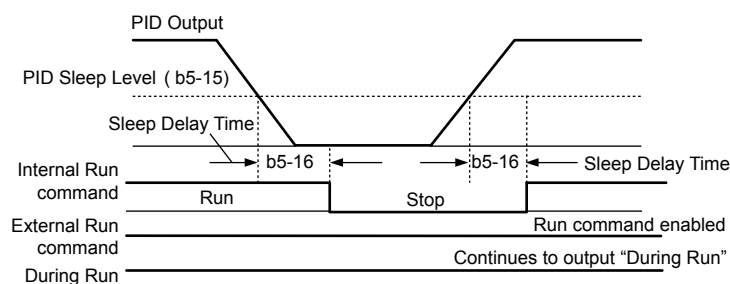

Figure 5.27 PID Sleep Operation

Notes on using the PID Sleep function

- The PID Sleep function is active even when PID control is disabled.
- The PID Sleep function stops the motor according to the stopping method set to b1-03.

The parameters necessary to control the PID Sleep function are explained below.

■ b5-15: PID Sleep Function Start Level

Sets the level that triggers PID Sleep.

The drive goes into Sleep mode if the PID output or frequency reference is smaller than b5-15 for longer than the time set to b5-16. The drive resumes operation when the PID output or frequency reference is above b5-15 for longer than the time set to b5-16.

No.	Name	Setting Range	Default
b5-15	PID Sleep Function Start Level	0.0 to 400.0 Hz	0.0 Hz

■ b5-16: PID Sleep Delay Time

Sets the delay time to activate or deactivate the PID Sleep function.

No.	Name	Setting Range	Default
b5-16	PID Sleep Delay Time	0.0 to 25.5 s	0.0 s

5.2 b: Application

■ b5-17: PID Accel/Decel Time

The PID acceleration/deceleration time is applied on the PID setpoint value.

When the setpoint changes quickly, the normal C1-□□ acceleration times reduce the responsiveness of the system as they are applied after the PID output. The PID accel/decel time helps avoid the hunting and overshoot and undershoot that can result from the reduced responsiveness.

The PID acceleration/deceleration time can be canceled using a digital input programmed for “PID SFS cancel” (H1-□□ = 34).

No.	Name	Setting Range	Default
b5-17	PID Accel/Decel Time	0.0 to 6000.0 s	0.0 s

■ b5-18: PID Setpoint Selection

Enables or disables parameter b5-19 for PID setpoint.

No.	Parameter Name	Setting Range	Default
b5-18	PID Setpoint Selection	0, 1	0

Setting 0: Disabled

Parameter b5-19 is not used as the PID setpoint.

Setting 1: Enabled

Parameter b5-19 is used as PID setpoint.

■ b5-19: PID Setpoint Value

Used as the PID setpoint if parameter b5-18 = 1.

No.	Name	Setting Range	Default
b5-19	PID Setpoint Value	0.00 to 100.00%	0.00%

■ b5-20: PID Setpoint Scaling

Determines the units for the PID Setpoint Value (b5-19) and monitors U5-01 and U5-04.

No.	Parameter Name	Setting Range	Default
b5-20	PID Setpoint Scaling	0 to 3	1

Setting 0: 0.01 Hz

The setpoint and PID monitors are displayed in Hz with a resolution of 0.01 Hz.

Setting 1: 0.01% (100.00%: Maximum Frequency)

The setpoint and PID monitors are displayed as a percentage with a resolution of 0.01%.

Setting 2: r/min (Set the Motor Poles)

The setpoint and PID monitors are displayed in r/min with a resolution of 1 r/min.

Setting 3: User Defined (Determined by b5-38 and b5-39)

Parameters b5-38 and b5-39 determine the units and resolution used to display the values the setpoint in b5-19, and PID monitors U1-01 and U1-04.

■ b5-34: PID Output Lower Limit

Sets the minimum possible PID controller output as a percentage of the maximum output frequency (E1-04). The lower limit is disabled when set to 0.00%

No.	Name	Setting Range	Default
b5-34	PID Output Lower Limit	-100.0 to 100.0%	0.00%

■ b5-35: PID Input Limit

Sets the maximum allowed PID input as a percentage of the maximum output frequency (E1-04). Parameter b5-35 acts as a bipolar limit.

No.	Name	Setting Range	Default
b5-35	PID Input Limit	0 to 1000.0%	1000.0%

■ b5-38, b5-39: PID Setpoint User Display, PID Setpoint Display Digits

When parameter b5-20 is set to 3, parameters b5-38 and b5-39 set a user-defined display for the PID setpoint (b5-19) and PID feedback monitors (U5-01, U5-04).

Parameter b5-38 determines the display value when the maximum frequency is output and parameter b5-39 determines the number of digits. The setting value is equal to the number of decimal places.

No.	Name	Setting Range	Default
b5-38	PID Setpoint User Display	1 to 60000	Determined by b5-20
b5-39	PID Setpoint Display Digits	0 to 3	Determined by b5-20

■ b5-40: Frequency Reference Monitor Content During PID

Sets the content of the frequency reference monitor display (U1-01) when PID control is active.

No.	Name	Setting Range	Default
b5-40	Frequency Reference Monitor Content During PID	0, 1	0

Setting 0: Frequency Reference after PID

Monitor U1-01 displays the frequency reference increased or reduced for the PID output.

Setting 1: Frequency Reference

Monitor U1-01 displays the frequency reference value.

■ b5-47: PID Output Reverse Selection 2

Determines whether a negative PID output reverses the direction of drive operation. When the PID function is used to trim the frequency reference (b5-01 = 3 or 4), this parameter has no effect and the PID output will not be limited (same as b5-11 = 1).

No.	Name	Setting Range	Default
b5-47	PID Output Reverse Selection 2	0, 1	1

Setting 0: Reverse Disabled

Negative PID output will be limited to 0 and the drive output will be stopped.

Setting 1: Reverse Enabled

Negative PID output will cause the drive to run in the opposite direction.

5.2 b: Application

■ Fine-Tuning PID

Follow the directions below to fine tune PID control parameters:

Table 5.12 PID Fine Tuning

Goal	Tuning Procedure	Result
Suppress overshoot	<ul style="list-style-type: none"> • Reduce the derivative time (b5-05) • Increase the integral time (b5-03) 	<p>The graph plots Response vs. Time. A horizontal dashed line represents the target value. The 'Before adjustment' curve rises to a peak above the target line (overshoot) before settling. The 'After adjustment' curve rises to the target line more smoothly and reaches it faster.</p>
Achieve stability quickly while allowing some overshoot	<ul style="list-style-type: none"> • Decrease the integral time (b5-03) • Increase the derivative time (b5-05) 	<p>The graph plots Response vs. Time. The 'After adjustment' curve reaches the target line more quickly than the 'Before adjustment' curve, but it has a higher overshoot peak.</p>
Suppress long cycle oscillations (longer than the integral time setting)	Increase the integral time (b5-03)	<p>The graph plots Response vs. Time. The 'Before adjustment' curve shows large, slow oscillations around the target line. The 'After adjustment' curve shows much smaller and faster oscillations.</p>
Suppress short cycle oscillations	<ul style="list-style-type: none"> • If oscillation cycle time is close to the derivative time, reduce the derivative time (b5-05). • If the derivative time is set to 0.00 s and oscillations are still a problem, reduce the proportional gain (b5-02) or increase the PID primary delay time (b5-08) 	<p>The graph plots Response vs. Time. The 'Before adjustment' curve shows high-frequency oscillations around the target line. The 'After adjustment' curve shows much smaller and slower oscillations.</p>

◆ b6: Dwell Function

The Dwell function temporarily holds the frequency reference at a predefined value for a set time then continues accelerating or decelerating.

The Dwell function helps prevent speed loss when starting and stopping a heavy load with induction motors. When running a PM motor in V/f control, the pause in acceleration allows the PM motor rotor to align with the stator field of the motor and reduce the starting current.

Figure 5.28 illustrates how the Dwell function works.

Note: Set the stopping method to "Ramp to Stop" (b1-03 = 0) to use the Dwell function.

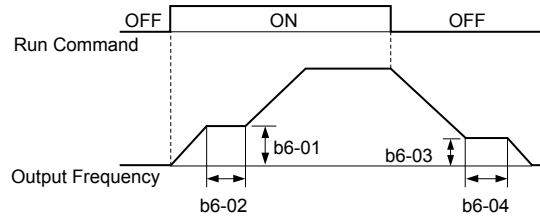

Figure 5.28 Dwell Function at Start and Stop

■ **b6-01, b6-02: Dwell Reference, Dwell Time at Start**

Parameter b6-01 determines the frequency that is held for the time set in b6-02 during acceleration.

No.	Name	Setting Range	Default
b6-01	Dwell Reference at Start	0.0 to 400.0 Hz	0.0 Hz
b6-02	Dwell Time at Start	0.0 to 10.0 s	0.0 s

■ **b6-03, b6-04: Dwell Reference, Dwell Time at Stop**

Parameter b6-03 determines the frequency that is held for the time set in b6-04 during deceleration.

No.	Name	Setting Range	Default
b6-03	Dwell Reference at Stop	0.0 to 400.0 Hz	0.0 Hz
b6-04	Dwell Time at Stop	0.0 to 10.0 s	0.0 s

◆ **b7: Droop Control (CLV, CLV/PM)**

Note: PM motor control modes are not available on 600 V class drives, models 5A□□□□.

Droop control automatically balances the load level between two motors driving the same load. Droop control must be activated in one of the drives controlling these motors. The drive in which Droop control is activated shifts the load from one motor to another by automatically reducing the speed when the torque reference rises, and automatically increasing the speed when the torque reference falls.

Note: Disable Feed Forward (n5-01 = 0) whenever using Droop control.

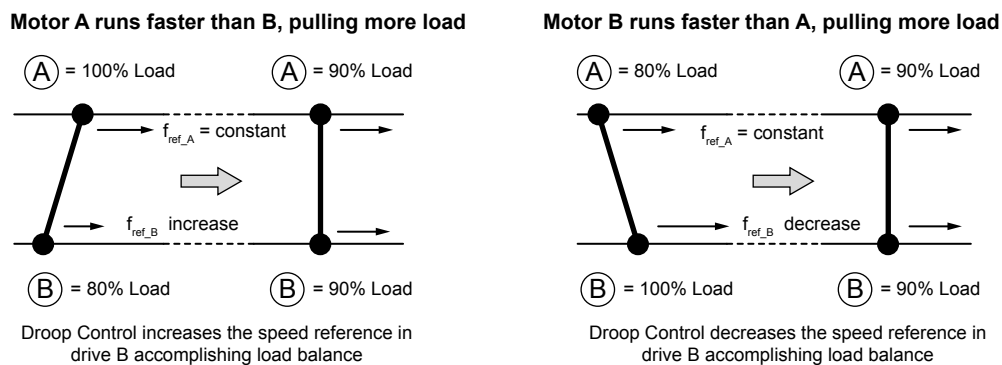

Figure 5.29 Droop Control Application

■ **b7-01: Droop Control Gain**

Sets the amount of speed reduction when the torque reference is 100%. The gain is set as a percentage of the maximum output frequency. A setting of 0.0% disables the Droop control function.

No.	Parameter Name	Setting Range	Default
b7-01	Droop Control Gain	0.0 to 100.0%	0.0%

5.2 b: Application

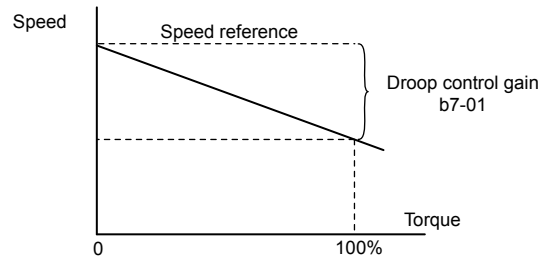

Figure 5.30 Droop Control Gain

■ b7-02: Droop Control Delay Time

Adjusts the responsiveness of Droop control. Reduce the setting if the reaction time is too long, and increase the setting if hunting occurs.

No.	Parameter Name	Setting Range	Default
b7-02	Droop Control Delay Time	0.03 to 2.00 s	0.05 s

■ b7-03: Droop Control Limit Selection

Enables or disables the droop control limit.

No.	Parameter Name	Setting Range	Default
b7-03	Droop Control Limit Selection	0, 1	1

Setting 0: Disabled

Setting 1: Enabled

◆ b8: Energy Saving

The Energy Saving feature improves overall system operating efficiency by operating the motor at its most efficient level.

- Note:**
1. Energy Saving is not designed for applications that experience instantaneous heavy loads or applications that rarely operate with light load conditions.
 2. Energy Saving is designed for applications with variable torque (Normal Duty) and is not appropriate for applications where the load may suddenly increase.
 3. The performance of the Energy Saving function depends on the accuracy of the motor data. Always perform Auto-Tuning and correctly enter the motor data before using this function.

■ b8-01: Energy Saving Control Selection

Enables or disables the Energy Saving function.

No.	Parameter Name	Setting Range	Default
b8-01	Energy Saving Control Selection	0, 1	Determined by A1-02

Setting 0: Disabled

Setting 1: Enabled

■ b8-02: Energy Saving Gain (OLV, CLV)

Sets the gain level for Energy Saving. A higher value results in lower magnetization of the motor and less energy consumption. If the value is set too high the motor may stall.

No.	Name	Setting Range	Default
b8-02	Energy Saving Gain	0.0 to 10.0	Determined by A1-02

■ b8-03: Energy Saving Control Filter Time Constant (OLV, CLV)

Sets the response time for Energy Saving. A lower value allows for a quicker response; however a value that is too low may cause instability.

No.	Name	Setting Range	Default
b8-03	Energy Saving Control Filter Time Constant	0.00 to 10.00 s	Determined by A1-02, C6-01, and o2-04

■ b8-04: Energy Saving Coefficient Value (V/f, V/f w/PG)

Fine tunes Energy Saving control. Adjust this setting while viewing the output power monitor (U1-08) and running the drive with a light load.

A low setting results in less output voltage and less energy consumption. If the value is set too low the motor may stall. The default setting depends on the capacity of the drive.

No.	Name	Setting Range	Default
b8-04	Energy Saving Coefficient Value	0.00 to 655.00	Determined by C6-01, E2-11, and o2-04

Note: The default value changes if the motor rated capacity set to E2-11 is changed. The Energy Saving coefficient is set automatically when Auto-Tuning for Energy Saving is performed ([Refer to Auto-Tuning on page 135](#)).

■ b8-05: Power Detection Filter Time (V/f, V/f w/PG)

Determines how often in milliseconds the output power is measured. The Energy Saving function continuously searches out the lowest output voltage to achieve minimum output power.

Reducing this setting increases the response time. If the filter time is too short, the motor may become unstable with a lighter load.

No.	Name	Setting Range	Default
b8-05	Power Detection Filter Time	0 to 2000 ms	20 ms

■ b8-06: Search Operation Voltage Limit (V/f, V/f w/PG)

Sets the voltage limit for the Speed Search optimal output voltage detection as a percentage of the maximum output voltage. The drive will keep the output voltage above this level during the search operation to prevent motor stalling.

Note: If set too low, the motor may stall when the load is suddenly increased. Disabled when set to 0. Setting this value to 0 does not disable Energy Saving.

No.	Name	Setting Range	Default
b8-06	Search Operation Voltage Limit	0 to 100%	0%

■ b8-16: Energy Saving Parameter (Ki) for PM Motors

Coefficient to adjust torque linearity.

Set to the Ki value specified on the motor nameplate.

Setting E5-01, Motor Code Selection, to 1□□□ or 2□□□ automatically sets the calculated value. This set value cannot be changed. If oscillation occurs when Energy Saving is enabled (b8-01 = 1), check the value displayed in monitor U5-21. If the value displayed differs from the Ki value written on the motor nameplate, set b8-16 accordingly.

No.	Name	Setting Range	Default
b8-16	Energy Saving Parameter (Ki) for PM Motors	0.00 to 2.00	1.00

■ b8-17: Energy Saving Parameter (Kt) for PM Motors

Coefficient to adjust torque linearity.

Set to the Kt value specified on the motor nameplate.

Setting E5-01, Motor Code Selection, to 1□□□ or 2□□□ automatically sets the calculated value. This set value cannot be changed. If oscillation occurs when Energy Saving is enabled (b8-01 = 1), check the value displayed in monitor U5-22. If the value displayed differs from the Kt value written on the motor nameplate, set b8-17 accordingly.

5.2 b: Application

No.	Name	Setting Range	Default
b8-16	Energy Saving Parameter (Kt) for PM Motors	0.00 to 2.00	1.00

◆ b9: Zero Servo

The Zero Servo function is a position loop that can be used in CLV and CLV/PM control modes to lock the motor at a certain position.

To activate Zero Servo mode, use a digital input set for H1-□□ = 72 and the drive will decelerate when this input is closed. The drive goes into Zero Servo mode and holds the current position when the motor speed falls below the level set to parameter b2-01. The drive accelerates when the input assigned to trigger the Zero Servo function is released and the Run command is still present.

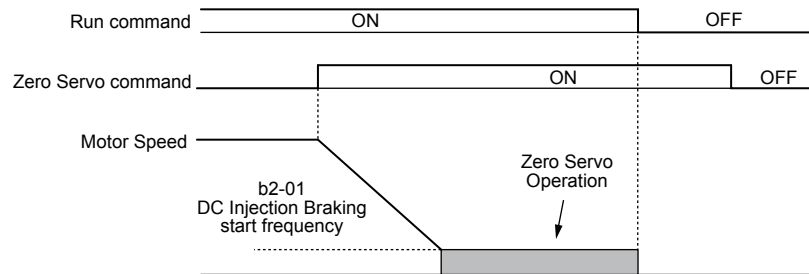

Figure 5.31 Zero Servo Operation

When Zero Servo mode is active, the deviation between the rotor position and the zero position is displayed in monitor U6-22 (monitor value must be divided by 4 to get the deviation in actual encoder pulses).

A digital output programmed for “Zero Servo complete” (H2-□□ = 33) is turned on when the rotor position is within the zero position, plus or minus the Zero Servo completion width set to parameter b9-02.

- Note:**
1. The Run command must remain on when using the Zero Servo function. Zero Servo will not hold the load in place if the Run command is switched off.
 2. When the Zero Servo command has shut off, the Zero Servo Completion digital output width also shuts off.
 3. Avoid using Zero Servo to lock 100% load for long periods, as this can trigger a fault. If such loads need to be held in place for long periods, either make sure the current is less than 50% of the drive rated current during Zero Servo, or use a larger capacity drive.
 4. If the load rotates the motor when using CLV/PM, a dv4 fault may occur. To prevent this, either increase the Zero Servo gain (b9-01) or increase the number of pulses set to F1-19 that are required to trigger dv4.

■ b9-01: Zero Servo Gain

Adjusts the responsiveness of the Zero Servo position loop. Increase the value if the response is too slow and the deviation from the zero position rises too high when load is applied. Decrease the value if vibrations occur during Zero Servo operation.

Note: Before adjusting the Zero Servo gain, make sure the ASR parameters (C5-□□) are set up properly and vibration or hunting does not occur when running with a zero speed reference.

No.	Name	Setting Range	Default
b9-01	Zero Servo Gain	0 to 100	5

■ b9-02: Zero Servo Completion Width

Sets the output range of the Zero Servo completion signal. Enter the amount of deviation allowable from the desired position to trigger Zero Servo. An output terminal set for Zero Servo (H2-□□ = 33) will be triggered when the motor reaches the position Zero Servo plus or minus b9-02.

No.	Name	Setting Range	Default
b9-02	Zero Servo Completion Width	0 to 16383	10

5.3 C: Tuning

C parameters set the characteristics for acceleration, deceleration, and S-curves. Other parameters in the C group cover settings for slip compensation, torque compensation, and carrier frequency.

◆ C1: Acceleration and Deceleration Times

■ C1-01 to C1-08: Accel, Decel Times 1 to 4

Four different sets of acceleration and deceleration times can be set in the drive by digital inputs, motor selection, or switched automatically.

Acceleration time parameters always set the time to accelerate from 0 Hz to the maximum output frequency (E1-04). Deceleration time parameters always set the time to decelerate from maximum output frequency to 0 Hz. C1-01 and C1-02 are the default active accel/decel settings.

No.	Parameter Name	Setting Range	Default
C1-01	Acceleration Time 1	0.0 to 6000.0 s ^{<I>}	10.0 s
C1-02	Deceleration Time 1		
C1-03	Acceleration Time 2		
C1-04	Deceleration Time 2		
C1-05	Acceleration Time 3 (Motor 2 Accel Time 1)		
C1-06	Deceleration Time 3 (Motor 2 Decel Time 1)		
C1-07	Acceleration Time 4 (Motor 2 Accel Time 2)		
C1-08	Deceleration Time 4 (Motor 2 Accel Time 2)		

<I> The setting range for the acceleration and deceleration times is determined by the accel/decel time setting units in C1-10. For example, if the time is set in units of 0.01 s (C1-10 = 0), the setting range becomes 0.00 to 600.00 s.

Switching Acceleration Times by Digital Input

Accel/decel times 1 are active by default if no input is set. Activate accel/decel times 2, 3, and 4 by digital inputs (H1-□□ = 7 and 1A) as explained in [Table 5.13](#).

Table 5.13 Accel/Decel Time Selection by Digital Input

Accel/Decel Time Sel. 1 H1-□□ = 7	Accel/Decel Time Sel. 2 H1-□□ = 1A	Active Times	
		Acceleration	Deceleration
0	0	C1-01	C1-02
1	0	C1-03	C1-04
0	1	C1-05	C1-06
1	1	C1-07	C1-08

[Figure 5.32](#) shows an operation example for changing accel/decel. times. The example below requires that the stopping method be set for “Ramp to stop” (b1-03 = 0).

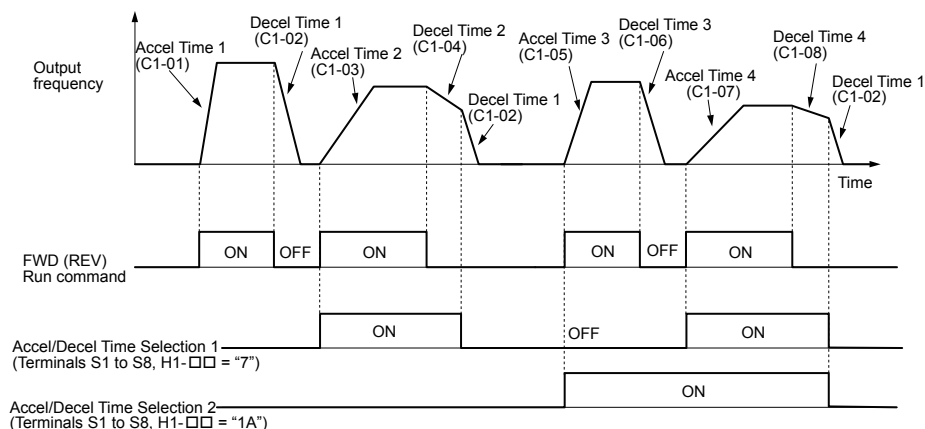

Figure 5.32 Timing Diagram of Accel/Decel Time Change

5.3 C: Tuning

Switching Acceleration and Deceleration Times by Motor Selection

When switching between motor 1 and 2 using a digital input (H1-□□ = 16), parameters C1-01 to C1-04 become accel/decel times 1 and 2 for motor 1, while C1-05 to C1-08 become accel/decel times 1 and 2 for motor 2. Accel/decel times 1 and 2 can be switched for each motor using a digital inputs set to H1-□□ = 7 like shown in [Table 5.14](#).

- Note:**
1. The motor 2 selection function cannot be used with PM motors.
 2. Attempting to use the digital input setting “Accel/Decel time 2 selection” (H1-□□ = 1A) together with motor 1/2 switching triggers an oPE03 error, indicating contradictory multifunction input settings.

Table 5.14 Motor Switching and Accel/Decel Time Combinations

Accel/Decel Time 1 (H1-□□ = 7)	Motor 1 Selected (Terminal set to H1-□□ = 16 OFF)		Motor 2 Selected (Terminal set to H1-□□ = 16 ON)	
	Accel	Decel	Accel	Decel
Open	C1-01	C1-02	C1-05	C1-06
Closed	C1-03	C1-04	C1-07	C1-08

Switching Accel/Decel Times by a Frequency Level

The drive can switch between different acceleration and deceleration times automatically. The drive will switch from accel/decel time 4 in C1-07 and C1-08 to the default accel/decel time in C1-01 and C1-02 (C1-05 and C1-06 for motor 2) when the output frequency exceeds the frequency level set to parameter C1-11. When the frequency falls below this level, the accel/decel times are switched back. [Figure 5.33](#) shows an operation example.

- Note:** Acceleration and deceleration times selected by digital inputs have priority over the automatic switching by the frequency level set to C1-11. For example, if accel/decel time 2 is selected, the drive will use only accel/decel time 2; it will not switch from accel/decel time 4 to the selected one.

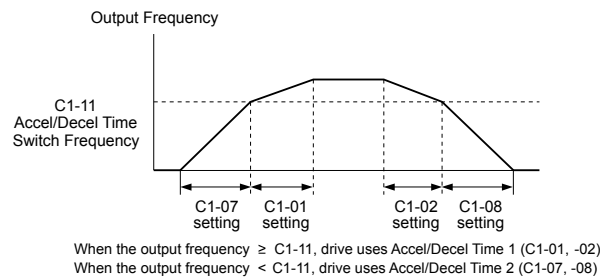

Figure 5.33 Accel/Decel Time Switching Frequency

■ C1-11: Accel/Decel Time Switching Frequency

Sets the frequency at which the drive switches between accel/decel time settings. See [Refer to Switching Accel/Decel Times by a Frequency Level on page 194](#).

No.	Parameter Name	Setting Range	Default
C1-11	Accel/Decel Time Switching Frequency	0.0 to 400.0 Hz </>	Determined by A1-02 </>

</> In AOLV/PM and CLV/PM control modes, the setting units and range are expressed as a percentage (0.0 to 100.0%) instead of in Hz.

- Note:** Setting C1-11 to 0.0 disables this function.

■ C1-09: Fast Stop Time

Sets a special deceleration used when a select group of faults occur (e.g., L8-03 Overheat Pre-Alarm Operation Selection) or when closing a digital input configured as H1-□□ = 15 (N.O. input) or 17 (N.C. input). A momentary closure of the digital input will trigger the Fast Stop operation; it does not have to be closed continuously.

The drive cannot be restarted after initiating a Fast Stop operation until after completing deceleration, clearing the Fast Stop input, and cycling the Run command.

A digital output programmed for “During Fast Stop” (H2-□□ = 4C) will be closed as long as Fast Stop is active.

No.	Parameter Name	Setting Range	Default
C1-09	Fast Stop Time	0.0 to 6000.0 s </>	10.0 s

</> The setting range for the acceleration and deceleration times is determined by the accel/decel time setting units in C1-10. For example, if the time is set in units of 0.01 s (C1-10 = 0), the setting range becomes 0.00 to 600.00 s

NOTICE: Rapid deceleration can trigger an overvoltage fault. The drive output shuts off when faulted and the motor coasts. Set an appropriate Fast Stop time to C1-09 to avoid this uncontrolled motor state and to ensure that the motor stops quickly and safely.

■ C1-10: Accel/Decel Time Setting Units

Determines the units for the acceleration and deceleration times set to C1-01 through C1-09 using parameter C1-10.

No.	Parameter Name	Setting Range	Default
C1-10	Accel/Decel Time Setting Units	0, 1	1

Setting 0: 0.01 s units

The accel/decel times are set in 0.01 s units. The setting range will be 0.00 to 600.00 s. C1-10 cannot be set to 0 if any of the parameters C1-01 to C1-09 are set to 600.1 seconds or more.

Setting 1: 0.1 s units

The accel/decel times are set in 0.1 s units. The setting range will be 0.0 to 6000.0 s.

◆ C2: S-Curve Characteristics

Use S-curve characteristics to smooth acceleration and deceleration and minimize abrupt shock to the load. Set S-curve characteristic time during acceleration/deceleration at start and acceleration/deceleration at stop. Increase the value set to C2-01 if the STo fault (Hunting Detection) occurs when starting a PM motor.

■ C2-01 to C2-04: S-Curve Characteristics

C2-01 through C2-04 set separate S-curves for each section of the acceleration or deceleration.

No.	Parameter Name	Setting Range	Default
C2-01	S-Curve Characteristic at Accel Start	0.00 to 10.00 s	Determined by A1-02
C2-02	S-Curve Characteristic at Accel End		0.20 s
C2-03	S-Curve Characteristic at Decel Start		0.20 s
C2-04	S-Curve Characteristic at Decel End		0.00 s

Figure 5.34 illustrates S-curve application.

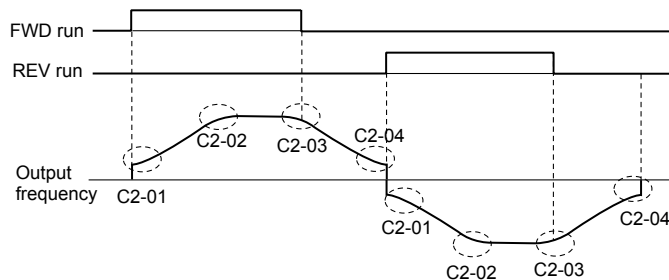

Figure 5.34 S-Curve Timing Diagram - FWD/REV Operation

Setting the S-curve will increase the acceleration and deceleration times.

- Actual accel time = accel time setting + (C2-01 + C2-02) / 2
- Actual decel time = decel time setting + (C2-03 + C2-04) / 2

◆ C3: Slip Compensation

The Slip Compensation function improves the speed accuracy of an induction motor. By adjusting the output frequency in accordance with the motor load, it compensates the slip and makes the motor speed equal to the frequency reference.

Note: Perform Auto-Tuning and make sure that the motor rated current (E2-01), the motor rated slip (E2-02), and the no-load current (E2-03) have all been set properly before making any adjustments to slip compensation parameters.

■ C3-01: Slip Compensation Gain

Sets the gain for the motor slip compensation function. Although this parameter rarely needs to be changed, adjustments may be necessary under the following circumstances:

- Increase the setting if the motor at constant speed is slower than the frequency reference.

5.3 C: Tuning

- Decrease the setting if the motor at constant speed is faster than the frequency reference.

No.	Parameter Name	Setting Range	Default
C3-01	Slip Compensation Gain	0.0 to 2.5	Determined by A1-02

Note: Default setting is 0.0 in V/f Control (A1-02 = 0), and 1.0 in Open Loop Vector Control (A1-02 = 2). In Closed Loop Vector Control, slip compensation corrects inaccuracies that can result from temperature fluctuation in the rotor.

■ C3-02: Slip Compensation Primary Delay Time

Adjusts the filter on the output side of the slip compensation function. Although this parameter rarely needs to be changed, adjustments may be necessary in the following situations:

- Decrease the setting when the slip compensation response is too slow.
- Increase this setting when speed is unstable.

No.	Parameter Name	Setting Range	Default
C3-02	Slip Compensation Primary Delay Time	0 to 10000 ms	Determined by A1-02

Note: Default for V/f Control (A1-02 = 0) is 2000 ms. Default for Open Loop Vector Control (A1-02 = 2) is 200 ms.

■ C3-03: Slip Compensation Limit

Sets the upper limit for the slip compensation function as a percentage of the motor rated slip (E2-02).

No.	Parameter Name	Setting Range	Default
C3-03	Slip Compensation Limit	0 to 250%	200%

The slip compensation limit is constant throughout the constant torque range (frequency reference \leq E1-06). In the constant power range (frequency reference \geq E1-06), it is increased based on C3-03 and the output frequency as shown in the following diagram.

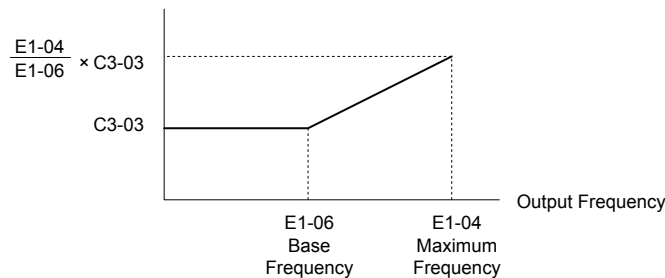

Figure 5.35 Slip Compensation Limit

■ C3-04: Slip Compensation Selection during Regeneration

Enables or disables slip compensation during regenerative operation. When slip compensation during regeneration has been activated and a regenerative load is applied, it might be necessary to use a dynamic braking option (braking resistor, braking resistor unit, or braking unit).

This function does not operate when the output frequency is too low, regardless of whether it has been enabled.

No.	Parameter Name	Setting Range	Default
C3-04	Slip Compensation Selection during Regeneration	0 to 2	0

Setting 0: Disabled

Slip compensation is not provided. Depending on the load and mode of operation, the actual motor speed will be lower or higher than the frequency reference.

Setting 1: Enabled (6 Hz and above)

Slip compensation is enabled during regenerative operation. It will not be active at output frequencies below 6 Hz.

Setting 2: Enabled (compensation provided wherever possible)

Slip compensation is enabled during regenerative operation and at frequencies as low as 2 Hz. The drive uses the motor rated slip set to E2-02 to automatically calculate the frequency range where compensation will be disabled.

■ C3-05: Output Voltage Limit Operation Selection

Determines if the motor flux reference is automatically reduced when output voltage reaches the saturation range.

If the input power supply voltage is low or the motor has a high voltage rating, this function improves the speed precision when moving heavy loads at high speeds. When selecting the drive, remember that the reduction in flux causes a slightly higher current at high speed when this function is enabled.

No.	Parameter Name	Setting Range	Default
C3-05	Output Voltage Limit Operation Selection	0, 1	0

Note: Available control modes for parameter C3-05 vary by drive model:
Models 2A0004 to 2A0415, 4A0002 to 4A0675, and 5A0003 to 5A0242: Available when A1-02 = 0, 1
Models 4A0930 and 4A1200: Available when A1-02 = 2, 3, 6, 7

Setting 0: Disabled

Setting 1: Enabled

■ C3-16: Output Voltage Limit Operation Start Level (Percentage Modulation)

Sets the output voltage limit operation start level (percentage modulation) when C3-05 is enabled.

Note: This parameter is only available in models 4A0930 and 4A1200.

No.	Parameter Name	Setting Range	Default
C3-16	Output Voltage Limit Operation Start Level	70.0 to 90.0%	85.0%

■ C3-17: Maximum Output Voltage Limit Level (Percentage Modulation)

Sets the output voltage limit operation determined by C3-18 (percentage modulation) when C3-05 is enabled.

Note: This parameter is only available in models 4A0930 and 4A1200.

No.	Parameter Name	Setting Range	Default
C3-17	Maximum Output Voltage Limit Level	85.0 to 100.0%	90.0%

■ C3-18: Output Voltage Limit Level

Sets the maximum percentage of output voltage reduction when C3-05 is enabled.

Note: This parameter is only available in models 4A0930 and 4A1200.

No.	Parameter Name	Setting Range	Default
C3-18	Output Voltage Limit Level	30.0 to 100.0%	90.0%

■ C3-21: Motor 2 Slip Compensation Gain

Improves the speed accuracy for motor 2 and functions in the same way that C3-01 functions for motor 1. Adjust this parameter only after setting the motor rated current (E4-01), motor rated slip (E4-02), and the motor no-load current (E4-03).

Refer to C3-01: Slip Compensation Gain on page 195 for details on adjusting this parameter.

No.	Parameter Name	Setting Range	Default
C3-21	Motor 2 Slip Compensation Gain	0.0 to 2.5	Determined by E3-01

Note: Default setting is 0.0 in V/f Control (E3-01 = 0). Default setting is 1.0 in Open Loop Vector Control (E3-01 = 2) and Closed Loop Vector Control (E3-01 = 3). In Closed Loop Vector Control, slip compensation gain acts as an adaptable gain.

■ C3-22: Motor 2 Slip Compensation Primary Delay Time

Functions for motor 2 the same way that C3-02 functions for motor 1.

Refer to C3-02: Slip Compensation Primary Delay Time on page 196 for details on adjusting this parameter.

No.	Parameter Name	Setting Range	Default
C3-22	Motor 2 Slip Compensation Primary Delay Time	0 to 10000 ms	Determined by A1-02

Note: The default for V/f Control (E3-01 = 0) is 2000 ms. The default for Open Loop Vector Control (E3-01 = 2) is 200 ms.

5.3 C: Tuning

■ C3-23: Motor 2 Slip Compensation Limit

Sets the upper limit for the slip compensation function as a percentage of the motor rated slip (E4-02).

No.	Parameter Name	Setting Range	Default
C3-23	Motor 2 Slip Compensation Limit	0 to 250%	200%

The slip compensation limit is constant throughout the constant torque range (frequency reference \leq E3-06). In the constant power range (frequency reference \geq E3-06), it is increased based on C3-23 and the output frequency as illustrated in [Figure 5.36](#).

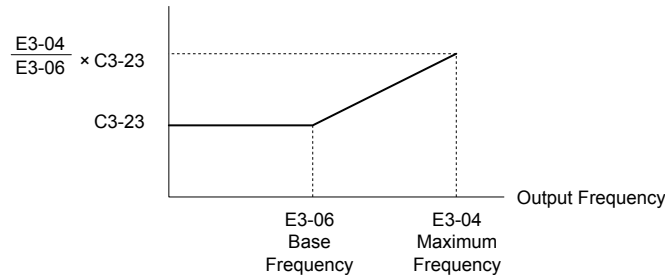

Figure 5.36 Slip Compensation Limit

■ C3-24: Motor 2 Slip Compensation Selection during Regeneration

Functions for motor 2 the same way that C3-04 functions for motor 1.

[Refer to C3-04: Slip Compensation Selection during Regeneration on page 196](#) for details on adjusting this parameter.

No.	Parameter Name	Setting Range	Default
C3-24	Motor 2 Slip Compensation Selection during Regeneration	0 to 2	0

Setting 0: Disabled

Setting 1: Enabled (6 Hz and above)

Setting 2: Enabled (compensation provided wherever possible)

◆ C4: Torque Compensation

The torque compensation function compensates for insufficient torque production at start-up or when a load is applied.

Note: Set the motor parameters and V/f pattern properly before setting torque compensation parameters.

■ C4-01: Torque Compensation Gain

Sets the gain for the torque compensation function.

No.	Parameter Name	Setting Range	Default
C4-01	Torque Compensation Gain	0.00 to 2.50	Determined by A1-02

Torque Compensation in V/f, V/f w/Pg, and OLV/PM:

Note: PM motor control modes are not available on 600 V class drives, models 5A□□□□.

The drive calculates the motor primary voltage loss using the output current and the termination resistor value (E2-05 for IM motors, E5-05 for PM motors) and adjusts the output voltage to compensate insufficient torque at start or when load is applied. The effects of this voltage compensation can be increased or decreased using parameter C4-01.

Torque Compensation in OLV:

The drive controls the motor excitation current (d-Axis current) and torque producing current (q-Axis current) separately. Torque compensation affects the torque producing current only. C4-01 works as a factor of the torque reference value that builds the torque producing current reference.

Adjustment

Although this parameter rarely needs to be changed, it may be necessary to adjust the torque compensation gain in small steps of 0.05 in the following situations:

- Increase this setting when using a long motor cable.
- Decrease this setting when motor oscillation occurs.

Adjust C4-01 so the output current does not exceed the drive rated current.

- Note:**
1. Refrain from adjusting torque compensation in Open Loop Vector Control, as it can have a negative effect on torque accuracy.
 2. Refrain from adjusting this parameter in OLV/PM. Setting this value too high can cause overcompensation and motor oscillation.

■ C4-02: Torque Compensation Primary Delay Time

Sets the delay time used for applying torque compensation.

No.	Parameter Name	Setting Range	Default
C4-02	Torque Compensation Primary Delay Time	0 to 60000 ms	Determined by A1-02

Adjustment

Although C4-02 rarely needs to be changed, adjustments may be necessary in the following situations:

- Increase this setting if the motor vibrates.
- Decrease this setting if the motor responds too slowly to changes in the load.

■ C4-03: Torque Compensation at Forward Start (OLV)

Sets the amount of torque at start in the forward direction to improve motor performance during start with a heavy load. Compensation is applied using the time constant set in parameter C4-05. Enable this function when the load pulls the motor in reverse when starting with a Forward run command. Setting 0.0% disables this feature.

No.	Parameter Name	Setting Range	Default
C4-03	Torque Compensation at Forward Start	0.0 to 200.0%	0.0%

■ C4-04: Torque Compensation at Reverse Start (OLV)

Sets the amount of torque reference at start in the reverse direction to improve motor performance during start with heavy load. Compensation is applied using the Torque Compensation Time set in parameter C4-05. Enable this function if the load pulls the motor in the forward direction when starting with a Reverse run command. Setting 0.0% disables this feature.

No.	Parameter Name	Setting Range	Default
C4-04	Torque Compensation at Reverse Start	-200.0 to 0.0%	0.0%

■ C4-05: Torque Compensation Time Constant (OLV)

Sets the time constant for applying the torque compensation at start that is set to C4-03 and C4-04.

No.	Parameter Name	Setting Range	Default
C4-05	Torque Compensation Time Constant	0 to 200 ms	10 ms

■ C4-06: Torque Compensation Primary Delay Time 2 (OLV)

Sets the time constant used during Speed Search or during regenerative operation. Adjust the value if an overvoltage fault occurs with sudden changes in the load or at the end of acceleration with high inertia load.

No.	Parameter Name	Setting Range	Default
C4-06	Torque Compensation Primary Delay Time 2	0 to 10000 ms	150 ms

- Note:** If C4-06 is set to a relatively large value, increase the setting in n2-03 (AFR Time Constant 2) proportionally.

■ C4-07: Motor 2 Torque Compensation Gain

Functions for motor 2 the same way that C4-01 functions for motor 1.

Refer to C3-01: Slip Compensation Gain on page 195 for details on adjusting this parameter.

No.	Parameter Name	Setting Range	Default
C4-07	Motor 2 Torque Compensation Gain	0.00 to 2.50	1.00

◆ C5: Automatic Speed Regulator (ASR)

The ASR controls the motor speed in V/f w/PG, CLV, AOLV/PM, and CLV/PM control modes and adjusts the output frequency (V/f w/PG) or torque reference (CLV, AOLV/PM, CLV/PM) to minimize the difference between frequency reference and actual motor speed.

Figure 5.37 and Figure 5.38 illustrate ASR functionality:

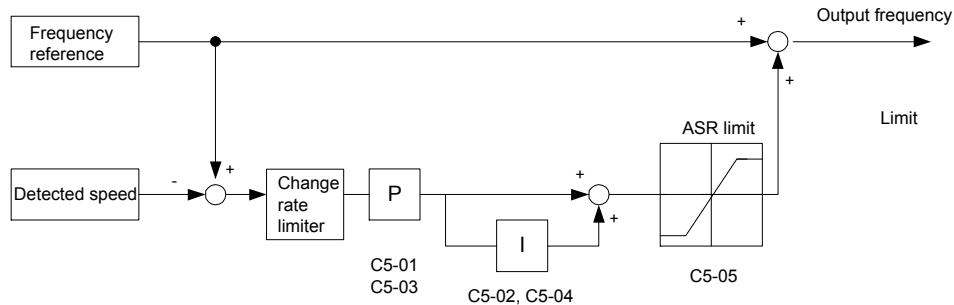

Figure 5.37 Speed Control Block Diagram for V/f Control with PG

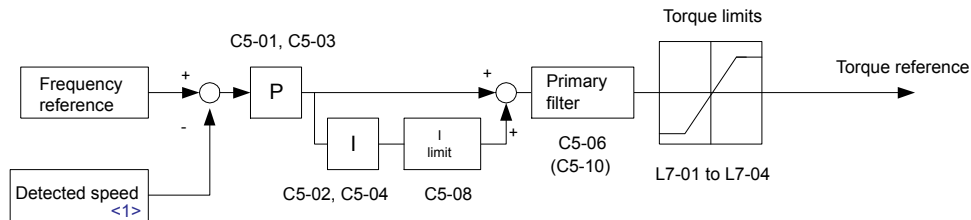

Figure 5.38 Speed Control Block Diagram for CLV, AOLV/PM and CLV/PM

<1> AOLV/PM estimates the speed using the motor model and does not require an encoder feedback signal.

Note: PM motor control modes are not available on 600 V class drives, models 5A□□□□.

■ Adjusting the ASR Parameters

Perform Auto-Tuning and set up all motor data correctly prior to adjusting ASR parameters.

Use analog output signals to monitor the frequency reference after softstarter (U1-16) and the motor speed (U1-05) when adjusting the ASR. Refer to H4: Multi-Function Analog Outputs on page 274 for details on setting up analog output functions.

Generally when tuning the ASR, optimize the ASR gain before adjusting the integral time settings. Always make adjustments with the load connected to the motor.

Adjusting the ASR Parameters in V/f Control with PG

In V/f Control with PG, the ASR settings change between two sets of parameters depending on the motor speed as described in C5-01, C5-03/C5-02, C5-04: ASR Proportional Gain 1, 2/ASR Integral Time 1, 2 on page 202.

Perform the following steps for adjusting ASR parameters:

1. Run the motor at minimum speed and increase ASR gain 2 (C5-03) as much as possible without oscillation.
2. Run the motor at minimum speed and decrease ASR integral time 2 (C5-04) as much as possible without oscillation.
3. Check the output current monitor to make sure that the output current is less than 50% of the drive rated current. If the value is higher than 50%, decrease C5-03 and increase C5-04.
4. Run the motor at maximum speed and increase ASR gain 1 (C5-01) as much as possible without oscillations.
5. Run the motor at maximum speed and decrease ASR integral time 1 (C5-02) as much as possible without oscillations.
6. If higher speed precision and faster response during acceleration or deceleration are required, enable integral control during accel/decel by setting parameter C5-12 to 1. Change the speed and make sure no over/undershoot occurs.

Adjusting the ASR Parameters in CLV, AOLV/PM, and CLV/PM

Note: PM motor control modes are not available on 600 V class drives, models 5A□□□□.

The drive is preset to use ASR settings C5-01/02 over the entire speed range in CLV, AOLV/PM, and CLV/PM. If required by the application, a second set of ASR parameters (C5-03/04) can be automatically activated depending on the motor speed or by using a digital input. *Refer to C5-01, C5-03/C5-02, C5-04: ASR Proportional Gain 1, 2/ASR Integral Time 1, 2 on page 202.*

Perform the following steps for adjusting ASR parameters:

1. Run the motor at zero speed and increase the ASR gain (C5-01) as much as possible without oscillation.
2. Run the motor at zero speed and decrease the ASR integral time (C5-02) as much as possible without oscillation.
3. Run at the normal operating speed. Check for over/undershoot when changing speed and for any oscillation.
4. If problems occur in step 3, increase the integral time and reduce the gain.
Alternatively, use different ASR settings for high and low speed. Set the values from step 1 and 2 to parameters C5-03 and C5-04, then set an ASR switching frequency in parameter C5-07. Run the motor at a speed higher than C5-07 and repeat step 3 while adjusting C5-01 and C5-02.

Solving Problems During ASR Setup

Use *Table 5.15* when making adjustments to ASR. Though the parameters listed below are for motor 1, the same changes can be made to the corresponding motor 2 parameters when running a second motor.

Table 5.15 ASR Setup Problems and Corrective Actions

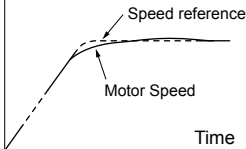
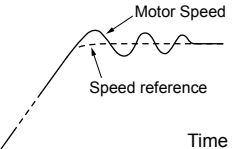
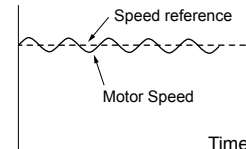
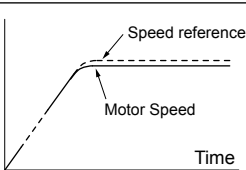
Problem		Possible Solutions
Slow response to speed changes or speed deviation lasts for too long		<ul style="list-style-type: none"> • Increase the ASR gain. • Decrease the integral time.
Overshoot or undershoot at the end of acceleration or deceleration		<ul style="list-style-type: none"> • Decrease the ASR gain. • Increase the integral time.
Vibration and oscillation occur at constant speed		<ul style="list-style-type: none"> • Decrease the ASR gain. • Increase the integral time. • Increase the ASR delay time (C5-06).
The motor slip is not fully compensated when running in V/f Control with PG		<ul style="list-style-type: none"> • Check the pulse number set to F1-01 and the gear ratio in F1-12 and F1-13. • Make sure the pulse signal from the encoder is set up properly. • Check monitor U6-04 and determine if the ASR is working at its output limit (setting of C5-05). If the ASR is at the output limit, increase C5-05.
Integral operation is enabled in V/f Control with PG (C5-12 = 1) and over/undershoot occurs when changing speed.	-	<ul style="list-style-type: none"> • Decrease the ASR gain. • Increase the integral time. • Reduce the ASR output limit set in C5-05.
Oscillation at low speed and response is too slow at high speed (or vice versa)	-	<ul style="list-style-type: none"> • V/f control: Use C5-01/02 and C5-03/04 to set up different ASR settings at minimum and maximum speed. • CLV, AOLV/PM, CLV/PM: Use C5-01, C5-02 and C5-03, C5-04 to define optimal ASR settings for high and low speed. Use C5-07 to define a switching frequency.

5.3 C: Tuning

■ C5-01, C5-03/C5-02, C5-04: ASR Proportional Gain 1, 2/ASR Integral Time 1, 2

These parameters adjust the responsiveness of the ASR.

Note: C5-01 is automatically set when ASR Tuning is performed (T1-01 = 9 or T2-01 = 9).

No.	Parameter Name	Setting Range	Default
C5-01	ASR Proportional Gain 1	0.00 to 300.00	Determined by A1-02
C5-02	ASR Integral Time 1	0.000 to 10.000 s	Determined by A1-02
C5-03	ASR Proportional Gain 2	0.00 to 300.00	Determined by A1-02
C5-04	ASR Integral Time 2	0.000 to 10.000 s	Determined by A1-02

These parameter settings will function differently depending on the control mode.

V/f Control with PG

Parameters C5-01 and C5-02 determine the ASR characteristics at maximum speed. Parameters C5-03 and C5-04 determine the characteristics at minimum speed.

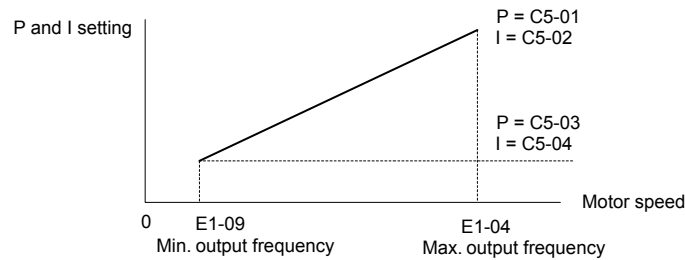

Figure 5.39 ASR Gain and Integral Time in V/f w/PG

CLV, AOLV/PM, and CLV/PM

Note: PM motor control modes are not available on 600 V class drives, models 5A□□□□.

In these control modes, parameters C5-03 and C5-04 define the ASR gain and integral time at zero speed. The settings in C5-01 and C5-02 are used at speeds above the setting in C5-07. C5-07 is set to 0 as the default so that C5-01 and C5-02 are used over the entire speed range. [Refer to C5-07: ASR Gain Switching Frequency on page 203.](#)

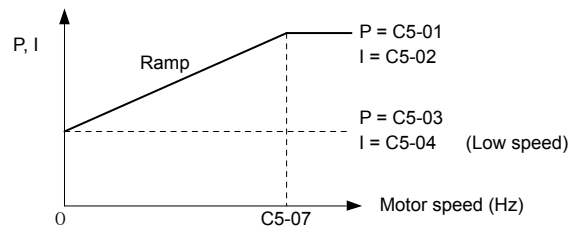

Figure 5.40 Low-speed and High-speed Gain Settings

The gain set in C5-03 can also be activated with a digital input programmed to “ASR gain switch” (H1-□□ = 77). When the terminal is open, the drive uses the ASR gain level set by the pattern in the figure above. When the terminal closes, C5-03 is used. The integral time set to C5-02 is used to change linearly between these settings. The ASR gain switch command from a multi-function input terminal overrides the switching frequency set to C5-07.

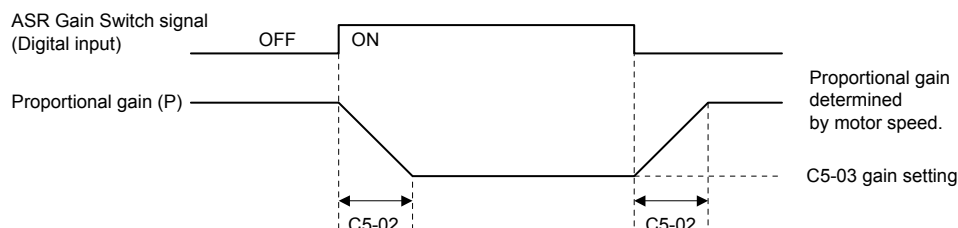

Figure 5.41 ASR Proportional Gain Switch

ASR Gain Tuning (C5-01, C5-03)

The higher this setting, the faster the speed response, although a setting that is too high can lead to oscillation. Increase this setting with larger loads to minimize the speed deviation.

ASR Integral Time Tuning (C5-02, C5-04)

Determines how fast a continuous speed deviation problem is eliminated. A setting that is too long reduces the responsiveness of the speed control. A setting that is too short can cause oscillation.

■ C5-05: ASR Limit

Sets the ASR output limit as a percentage of the maximum output frequency (E1-04). If the motor rated slip is high, the setting might need to be increased to provide proper motor speed control. Use the ASR output monitor U6-04 to determine if ASR is working at the limit set in C5-05. If ASR is working at the limit, make sure the PG pulses (F1-01), PG gear teeth (F1-12, F1-13), and the PG signal are set correctly before making further changes to C5-05.

No.	Parameter Name	Setting Range	Default
C5-05	ASR Limit	0.0 to 20.0%	5.0%

■ C5-06: ASR Primary Delay Time Constant

Sets the filter time constant for the time from the speed loop to the torque command output. Increase this setting gradually in increments of 0.01 for loads with low rigidity or when oscillation is a problem. This parameter rarely needs to be changed.

No.	Parameter Name	Setting Range	Default
C5-06	ASR Primary Delay Time Constant	0.000 to 0.500 s	Determined by A1-02

■ C5-07: ASR Gain Switching Frequency

Sets the frequency where the drive should switch between ASR proportional gain 1 and 2 (C5-01, C5-03) as well as between integral time 1 and 2 (C5-02, C5-04).

No.	Parameter Name	Setting Range	Default
C5-07	ASR Gain Switching Frequency	0.0 to 400.0 Hz <1>	Determined by A1-02 <1>

<1> In AOLV/PM and CLV/PM control modes the setting units and range are expressed as a percent (0.0 to 100.0%) instead of in Hz.

Note: A multi-function input set for the ASR gain switch (H1-□□ = 77) takes priority over the ASR gain switching frequency.

Switching the proportional gain and integral time in the low or high speed range can help stabilize operation and avoid resonance problems. A good switching point is 80% of the frequency where oscillation occurs or at 80% of the target speed. *Refer to C5-01, C5-03/C5-02, C5-04: ASR Proportional Gain 1, 2/ASR Integral Time 1, 2 on page 202.*

■ C5-08: ASR Integral Limit

Sets the upper limit for ASR as a percentage of the rated load.

No.	Parameter Name	Setting Range	Default
C5-08	ASR Integral Limit	0 to 400%	400%

■ C5-12: Integral Operation during Accel/Decel (V/f w/PG)

Enables integral operation during acceleration and deceleration. Use integral operation when driving a heavy load or a high inertia load (default). Set C5-12 to 1 to use integral operation for low inertia/high performance loads. Enabling integral operation may cause problems with overshoot at the end of acceleration and deceleration. *Refer to ASR Setup Problems and Corrective Actions on page 201* to solve such problems.

No.	Parameter Name	Setting Range	Default
C5-12	Integral Operation during Accel/Decel	0, 1	0

Setting 0: Disabled

Integral operation occurs only during constant speed and not during acceleration or deceleration.

Setting 1: Enabled

Integral operation is always enabled.

■ C5-17, C5-18: Motor Inertia, Load Inertia Ratio

C5-17 and C5-18 determine the ratio of the machine inertia to the inertia of the motor being used.

5.3 C: Tuning

Example: Setting C5-18 to 2.0 reflects a load inertia that is twice the motor inertia.

These parameters are set automatically when Inertia Tuning and ASR Tuning are performed in CLV and CLV/PM control modes. [Refer to Auto-Tuning on page 135](#) for details on Auto-Tuning or enter the data manually.

No.	Parameter Name	Setting Range	Default
C5-17	Motor Inertia	0.0001 to 600.00 kgm ²	Determined by C6-01, E5-01 and o2-04
C5-18	Load Inertia Ratio	0.0 to 6000.0	1.0

■ C5-21, C5-23 / C5-22, C5-24: Motor 2 ASR Proportional Gain 1, 2 / Integral Time 1, 2

These parameters function for motor 2 the same way that C5-01 through C5-04 function for motor 1. [Refer to C5-01, C5-03/C5-02, C5-04: ASR Proportional Gain 1, 2/ASR Integral Time 1, 2 on page 202](#) for details.

No.	Parameter Name	Setting Range	Default
C5-21	Motor 2 ASR Proportional Gain 1	0.00 to 300.00	Determined by E3-01
C5-22	Motor 2 ASR Integral Time 1	0.000 to 10.000 s	Determined by E3-01
C5-23	Motor 2 ASR Proportional Gain 2	0.00 to 300.00	Determined by E3-01
C5-24	Motor 2 ASR Integral Time 2	0.000 to 10.000 s	Determined by E3-01

■ C5-25: Motor 2 ASR Limit

Functions for motor 2 the same way that C5-05 functions for motor 1. Sets the ASR output limit for motor 2 as a percentage of the maximum output frequency (E4-04). [Refer to C5-05: ASR Limit on page 203](#) for details.

No.	Parameter Name	Setting Range	Default
C5-25	Motor 2 ASR Limit	0.0 to 20.0%	5.0%

■ C5-26: Motor 2 ASR Primary Delay Time Constant

Functions for motor 2 the same way that C5-06 functions for motor 1. Sets the filter time constant for the time from the speed loop to the torque command output. [Refer to C5-06: ASR Primary Delay Time Constant on page 203](#) for details. This parameter rarely needs to be changed.

No.	Parameter Name	Setting Range	Default
C5-26	Motor 2 ASR Primary Delay Time Constant	0.000 to 0.500 s	0.004 s

■ C5-27: Motor 2 ASR Gain Switching Frequency

Functions for motor 2 the same way that C5-07 functions for motor 1. Sets the frequency for motor 2 to change ASR proportional gain 1 and 2 (C5-21, C5-23) as well as the integral time 1 and 2 (C5-22, C5-24). [Refer to C5-01, C5-03/C5-02, C5-04: ASR Proportional Gain 1, 2/ASR Integral Time 1, 2 on page 202](#) for details.

No.	Parameter Name	Setting Range	Default
C5-27	Motor 2 ASR Gain Switching Frequency	0.0 to 400.0 Hz	0.0 Hz

Note: A multi-function input set for the ASR gain switch (H1-□□ = 77) takes priority over the ASR gain switching frequency.

■ C5-28: Motor 2 ASR Integral Limit

Functions for motor 2 the same way that C5-08 functions for motor 1. Sets the upper limit for ASR as a percentage of the rated load. [Refer to C5-08: ASR Integral Limit on page 203](#) for details.

No.	Parameter Name	Setting Range	Default
C5-28	Motor 2 ASR Integral Limit	0 to 400%	400%

■ C5-32: Integral Operation during Accel/Decel for Motor 2

Functions for motor 2 the same way that C5-12 functions for motor 1. Enables integral operation during acceleration and deceleration. [Refer to C5-12: Integral Operation during Accel/Decel \(V/f w/PG\) on page 203](#) for details.

No.	Parameter Name	Setting Range	Default
C5-32	Integral Operation during Accel/Decel for Motor 2	0, 1	0

Setting 0: Disabled

Integral operation occurs only during constant speed and not during acceleration or deceleration.

Setting 1: Enabled

Integral operation is always enabled.

■ C5-37, C5-38: Motor 2 Inertia, Motor 2 Load Inertia Ratio

These parameters function for motor 2 the same way that C5-17 and C5-18 function for motor 1. These parameters are set automatically when Inertia Tuning and ASR Tuning are performed for motor 2 in CLV and CLV/PM control modes. *Refer to Auto-Tuning on page 135* for details on Auto-Tuning or enter the data manually.

No.	Parameter Name	Setting Range	Default
C5-37	Motor 2 Inertia	0.0001 to 600.00 kgm ²	Determined by C6-01 and o2-04
C5-38	Motor 2 Load Inertia Ratio	0.0 to 6000.0	1.0

■ C5-39: Motor 2 ASR Primary Delay Time Constant 2

Sets the filter time constant in seconds for the time from the speed loop to the torque reference output when the Power KEB Ride-Thru is enabled (L2-29 = 1). Gradually increase this setting in increments of 0.01 s if oscillation occurs during Power KEB Ride-Thru

Note: This parameter is not available in models 4A0930 and 4A1200.

No.	Parameter Name	Setting Range	Default
C5-39	Motor 2 ASR Primary Delay Time Constant 2	0.000 to 0.500 s	0.000 s

◆ C6: Carrier Frequency**■ C6-01: Drive Duty Mode Selection**

The drive has two different duty modes from which to select based on the load characteristics. The drive rated current, overload capacity, and maximum output frequency will change depending upon the duty mode selection. Use parameter C6-01 to select Heavy Duty (HD) or Normal Duty (ND) for the application. *Refer to Heavy Duty and Normal Duty Ratings on page 462* for details about the rated current.

No.	Parameter Name	Setting Range	Default
C6-01	Duty Mode Selection	0, 1	1 (ND)

Table 5.16 Differences between Heavy Duty and Normal Duty

Characteristics	Heavy Duty Rating (HD)	Normal Duty Rating (ND)
C6-01	0	1
Performance		
Application	Use Heavy Duty Rating for applications requiring a high overload tolerance with constant load torque, such as extruders and conveyors.	Use Normal Duty Rating for applications in which the torque requirements drop along with the speed, such as fans and pumps where a high overload tolerance is not required.
Overload capability (oL2)	150% of drive rated Heavy Duty current for 60 s	120% of drive rated Normal Duty current for 60 s
Stall Prevention during Acceleration (L3-02)	150%	120%
Stall Prevention during Run (L3-06)	150%	120%
Default Carrier Frequency	2 kHz	2 kHz Swing PWM

Note: Changing the Duty Mode selection automatically changes the maximum size motor that the drive can run, sets the E2-□□ parameters to appropriate values (E4-□□ for motor 2), and recalculates parameter settings determined by motor capacity (e.g., b8-04, L2-03, n5-02, L3-24, C5-17, and C5-37).

5.3 C: Tuning

■ C6-02: Carrier Frequency Selection

Sets the switching frequency of the drive output transistors. Changes to the switching frequency lower audible noise and reduce leakage current.

Note: Increasing the carrier frequency above the default value automatically lowers the drive current rating. *Refer to Rated Current Depending on Carrier Frequency on page 479.*

No.	Parameter Name	Setting Range	Default
C6-02	Carrier Frequency Selection	1 to F <1>	Determined by A1-02, o2-04. Reset when C6-01 is changed.

<1> The setting range is 1, 2, and F for models 4A0515 to 4A1200

Note: The default setting for the carrier frequency differs based on the type of motor and the Duty Mode selection. The default is 2 kHz in HD, and “Swing PWM1” in ND. When using a PM motor, the default carrier frequency is 5.0 Hz.

Settings:

C6-02	Carrier Frequency	C6-02	Carrier Frequency	C6-02	Carrier Frequency
1	2.0 kHz	5	12.5 kHz (10.0 kHz)	9	Swing PWM 3
2	5.0 kHz (4.0 kHz)	6	15.0 kHz (12.0 kHz)	A	Swing PWM 4
3	8.0 kHz (6.0 kHz)	7	Swing PWM 1	F	User defined (C6-03 to C6-05)
4	10.0 kHz (8.0 kHz)	8	Swing PWM 2		

Note:

- Swing PWM uses a carrier frequency of 2.0 kHz as a base, then applies a special PWM pattern to reduce the audible noise.
- The value in parenthesis indicates the carrier frequency for AOLV/PM.

Guidelines for Carrier Frequency Parameter Setup

Symptom	Remedy
Speed and torque are unstable at low speeds	Lower the carrier frequency.
Noise from the drive affects peripheral devices	
Excessive leakage current from the drive	
Wiring between the drive and motor is too long <1>	
Audible motor noise is too loud	Increase the carrier frequency or use Swing PWM. <2>

<1> The carrier frequency may need to be lowered if the motor cable is too long. Refer to [Table 5.17](#).

<2> The default carrier frequency in ND is Swing PWM (C6-02 = 7), using a 2 kHz base. Increasing the carrier frequency is permissible when the drive is set for Normal Duty, however the drive rated current is reduced when the carrier frequency is increased.

Table 5.17 Wiring Distance and Carrier Frequency

Wiring Distance	Up to 50 m	Up to 100 m	Greater than 100 m
Recommended setting value for C6-02	1 to F (up to 15 kHz)	1 to 2 (up to 5 kHz), 7 (Swing PWM)	1 (up to 2 kHz), 7 (Swing PWM)

Note: The maximum cable length is 100 m when using OLV/PM (A1-02 = 5) or AOLV/PM (A1-02 = 6).

■ C6-03, C6-04, C6-05: Carrier Frequency Upper Limit, Lower Limit, Proportional Gain

These parameters set a user-defined or a variable carrier frequency. Set C6-02 to F to set the upper and lower limits and the carrier frequency proportional gain.

No.	Parameter Name	Setting Range	Default
C6-03	Carrier Frequency Upper Limit	1.0 to 15.0 kHz <1>	Determined by C6-02
C6-04	Carrier Frequency Lower Limit (V/f Control only)	1.0 to 15.0 kHz <1>	
C6-05	Carrier Frequency Proportional Gain (V/f Control only)	0 to 99 <2>	

<1> In AOLV/PM and CLV/PM control modes, the setting units and range are expressed as a percentage (0.0 to 100.0%) instead of in Hz.

<2> The setting range is 1.0 to 5.0 for models 4A0515 to 4A1200.

Setting a Fixed User Defined Carrier Frequency

A carrier frequency between the fixed selectable values can be entered in parameter C6-03 when C6-02 is set to F. In V/f Control, adjust parameter C6-04 to the same value as C6-03.

Setting a Variable Carrier Frequency (V/f Control)

In V/f Control, the carrier frequency can be set up to change linearly with the output frequency by setting the upper and lower limits for the carrier frequency and the carrier frequency proportional gain (C6-03, C6-04, C6-05) as shown in [Figure 5.42](#).

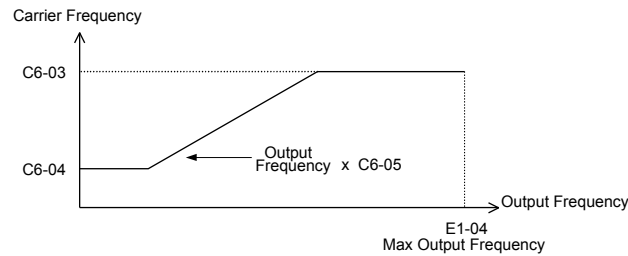

Figure 5.42 Carrier Frequency Changes Relative to Output Frequency

Note: When C6-05 is set lower than 7, C6-04 is disabled and the carrier frequency will be fixed to the value set in C6-03.

■ C6-09: Carrier Frequency during Rotational Auto-Tuning

Determines the carrier frequency while performing Rotational Auto-Tuning. Although this parameter rarely needs to be changed, when overcurrent problems occur when Auto-Tuning a high frequency motor or low impedance motor, it may be helpful to set C6-03 to a high value before setting C6-09 to 1.

Note: This parameter is not available in models 4A0930 and 4A1200.

No.	Parameter Name	Setting Range	Default
C6-09	Carrier Frequency during Rotational Auto-Tuning	0, 1	0

Setting 0: 5 kHz

Setting 1: Same value set to C6-03

5.4 d: Reference Settings

The figure below gives an overview of the reference input, selections, and priorities.

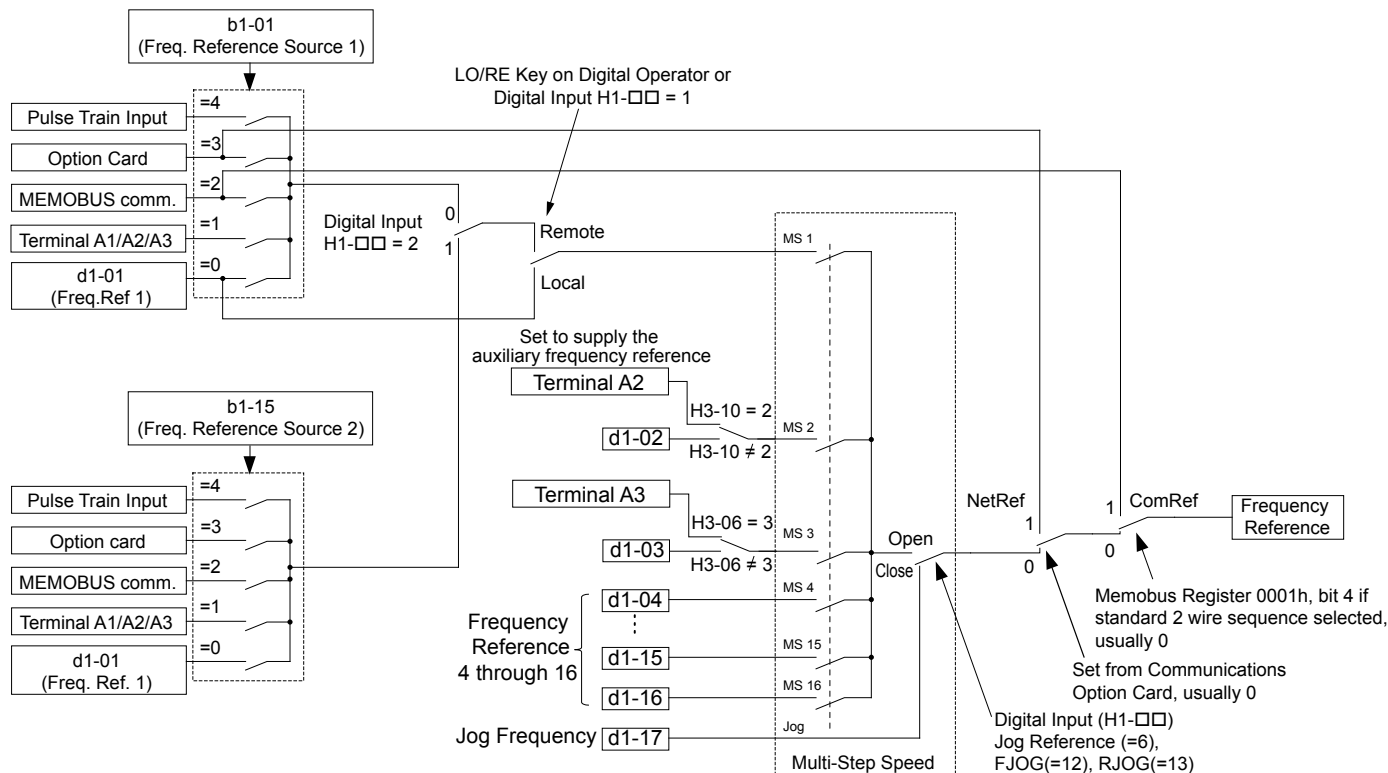

Figure 5.43 Frequency Reference Setting Hierarchy

◆ d1: Frequency Reference

■ d1-01 to d1-17: Frequency Reference 1 to 16 and Jog Frequency Reference

The drive lets the user switch between up to 17 preset frequency references during run (including the Jog reference) through the digital input terminals. The drive uses the acceleration and deceleration times that have been selected when switching between each frequency reference.

The Jog frequency overrides all other frequency references and must be selected by a separate digital input.

The multi-speed references 1, 2, and 3 can be provided by analog inputs.

No.	Parameter Name	Setting Range	Default
d1-01 to d1-16	Frequency Reference 1 to 16	0.00 to 400.00 Hz <1> <2>	0.00 Hz <2>
d1-17	Jog Frequency Reference	0.00 to 400.00 Hz <1> <2>	6.00 Hz <2>

<1> The upper limit is determined by the maximum output frequency (E1-04) and upper limit for the frequency reference (d2-01).

<2> Setting units are determined by parameter o1-03. The default is "Hz" (o1-03 = 0) in V/f, V/f w/PG, OLV, CLV, and OLV/PM control modes. The default for AOLV/PM and CLV/PM control modes expresses the frequency reference as a percentage (o1-03 = 1).

Multi-Step Speed Selection

To use several speed references for a multi-step speed sequence, set the H1-□□ parameters to 3, 4, 5, and 32. To assign the Jog reference to a digital input, set H1-□□ to 6.

Notes on using analog inputs as Multi-Speed 1, 2, and 3:

• Multi-Step Speed 1

Set b1-01 to 1 to set terminal A1 analog input to Multi-Step Speed 1.

Set b1-01 to 0 when setting d1-01, Frequency Reference 1, to Multi-Step Speed 1.

• Multi-Step Speed 2

Set H3-06, Terminal A3 Function Selection, to 2 (Auxiliary Frequency Reference 1) when setting terminal A3 analog input to Multi-Step Speed 2.

Set H3-06 to F (Through mode) when setting d1-02, Frequency Reference 2, to Multi-Step Speed 2.

• **Multi-Step Speed 3**

Set H3-10, Terminal A2 Function Selection, to 3 (Auxiliary Frequency Reference 2) when setting terminal A2 analog input to Multi-Step Speed 3.

Set H3-10 to F (Through mode) when setting d1-03, Frequency Reference 3, to Multi-Step Speed 3.

Set H3-09 to 0 and set DIP switch S1 on the control circuit terminal board to V (voltage) when inputting 0 to 10 V to terminal A2 analog input.

Select the different speed references as shown in *Table 5.18*. *Figure 5.44* illustrates the multi-step speed selection.

Table 5.18 Multi-Step Speed Reference and Terminal Switch Combinations

Reference	Multi-Step Speed H1-□□ = 3	Multi-Step Speed 2 H1-□□ = 4	Multi-Step Speed 3 H1-□□ = 5	Multi-Step Speed 4 H1-□□ = 32	Jog Reference H1-□□ = 6
Frequency Reference 1 (set in b1-01)	OFF	OFF	OFF	OFF	OFF
Frequency Reference 2 (d1-02 or input terminal A1, A2, A3)	ON	OFF	OFF	OFF	OFF
Frequency Reference 3 (d1-03 or input terminal A1, A2, A3)	OFF	ON	OFF	OFF	OFF
Frequency Reference 4 (d1-04)	ON	ON	OFF	OFF	OFF
Frequency Reference 5 (d1-05)	OFF	OFF	ON	OFF	OFF
Frequency Reference 6 (d1-06)	ON	OFF	ON	OFF	OFF
Frequency Reference 7 (d1-07)	OFF	ON	ON	OFF	OFF
Frequency Reference 8 (d1-08)	ON	ON	ON	OFF	OFF
Frequency Reference 9 (d1-09)	OFF	OFF	OFF	ON	OFF
Frequency Reference 10 (d1-10)	ON	OFF	OFF	ON	OFF
Frequency Reference 11 (d1-11)	OFF	ON	OFF	ON	OFF
Frequency Reference 12 (d1-12)	ON	ON	OFF	ON	OFF
Frequency Reference 13 (d1-13)	OFF	OFF	ON	ON	OFF
Frequency Reference 14 (d1-14)	ON	OFF	ON	ON	OFF
Frequency Reference 15 (d1-15)	OFF	ON	ON	ON	OFF
Frequency Reference 16 (d1-16)	ON	ON	ON	ON	OFF
Jog Frequency Reference (d1-17) <1>	–	–	–	–	ON

<1> The Jog frequency overrides all other frequency references.

5.4 d: Reference Settings

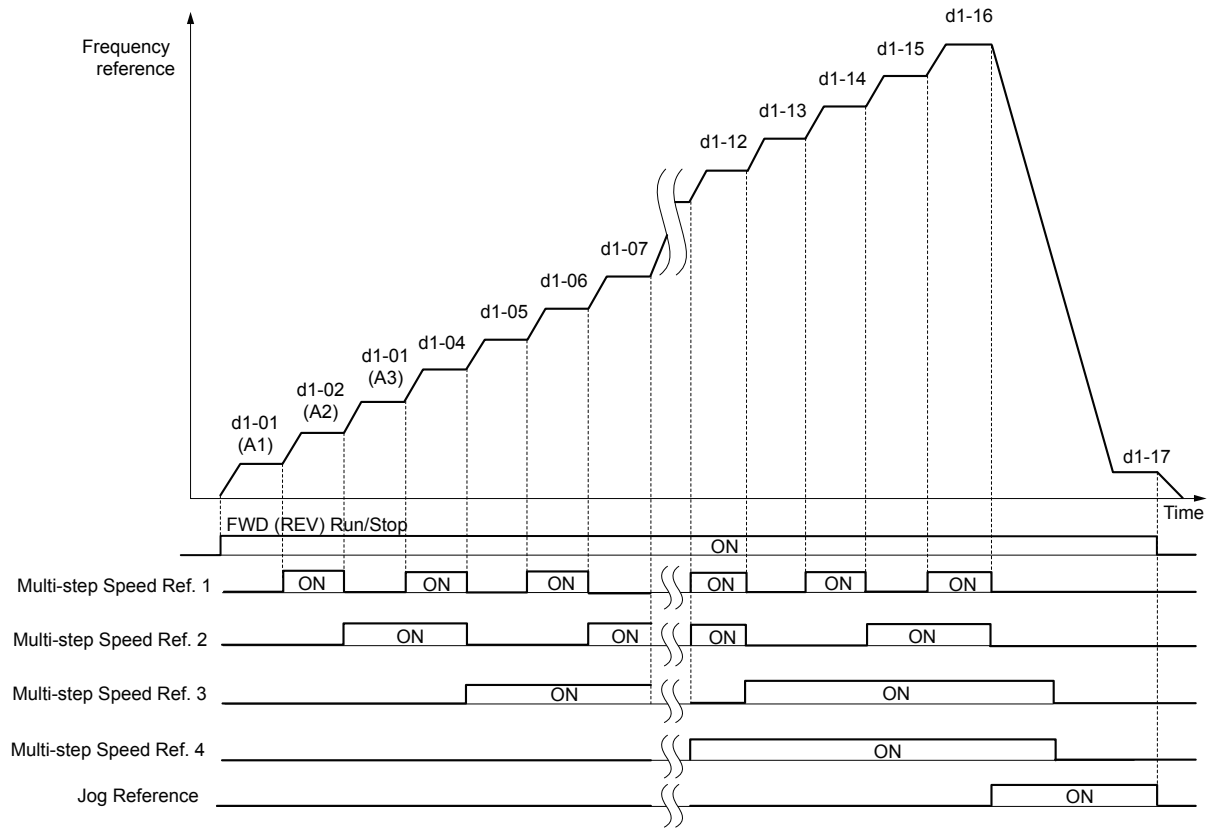

Figure 5.44 Preset Reference Timing Diagram

◆ d2: Frequency Upper/Lower Limits

Upper and lower frequency limits prevent motor speed from going above or below levels that may cause resonance or equipment damage.

■ d2-01: Frequency Reference Upper Limit

Sets the maximum frequency reference as a percentage of the maximum output frequency. This limit applies to all frequency references.

Even if the frequency reference is set to a higher value, the drive internal frequency reference will not exceed this value.

No.	Parameter Name	Setting Range	Default
d2-01	Frequency Reference Upper Limit	0.0 to 110.0%	100.0%

■ d2-02: Frequency Reference Lower Limit

Sets the minimum frequency reference as a percentage of the maximum output frequency. This limit applies to all frequency references.

If a lower reference than this value is entered, the drive will run at the limit set to d2-02. If the drive is started with a lower reference than d2-02, it will accelerate up to d2-02.

No.	Parameter Name	Setting Range	Default
d2-02	Frequency Reference Lower Limit	0.0 to 110.0%	0.0%

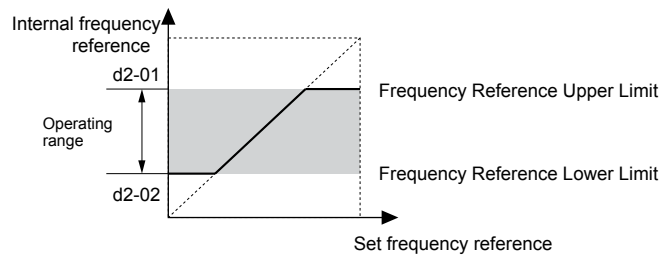

Figure 5.45 Frequency Reference: Upper and Lower Limits

■ d2-03: Master Speed Reference Lower Limit

Sets a lower limit as a percentage of the maximum output frequency that will only affect a frequency reference entered from the analog input terminals (A1, A2, or A3). This is unlike parameter d2-02, which affects all frequency references regardless of their source.

Note: When lower limits are set to both parameters d2-02 and d2-03, the drive uses the greater of those two values as the lower limit.

No.	Parameter Name	Setting Range	Default
d2-03	Master Speed Reference Lower Limit	0.0 to 110.0%	0.0%

◆ d3: Jump Frequency

■ d3-01 to d3-04: Jump Frequencies 1, 2, 3 and Jump Frequency Width

The Jump frequencies are frequency ranges at which the drive will not operate. The drive can be programmed with three separate Jump frequencies to avoid operating at speeds that cause resonance in driven machinery. If the speed reference falls within a Jump frequency dead band, the drive will clamp the frequency reference just below the dead band and only accelerate past it when the frequency reference rises above the upper end of the dead band.

Setting parameters d3-01 through d3-03 to 0.0 Hz disables the Jump frequency function.

No.	Parameter Name	Setting Range	Default
d3-01	Jump Frequency 1	0.0 to 400.0 Hz <1>	0.0 Hz <1>
d3-02	Jump Frequency 2	0.0 to 400.0 Hz <1>	0.0 Hz <1>
d3-03	Jump Frequency 3	0.0 to 400.0 Hz <1>	0.0 Hz <1>
d3-04	Jump Frequency Width	0.0 to 20.0 Hz <2>	1.0 Hz <2>

<1> In AOLV/PM and CLV/PM control modes, the setting units and range are expressed as a percentage instead of in Hz.

<2> In AOLV/PM and CLV/PM control modes, the setting units and range are expressed as a percent instead of in Hz. The setting range is 0.0 to 40.0% and the default is 1.0%.

Figure 5.46 shows the relationship between the Jump frequency and the output frequency.

5.4 d: Reference Settings

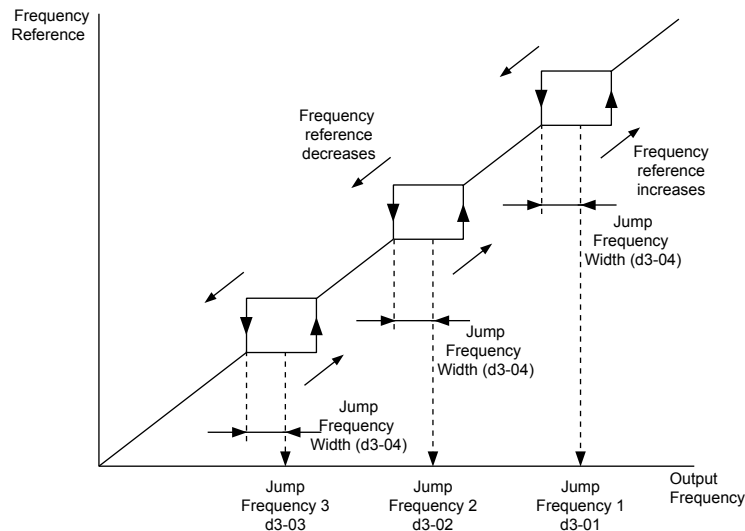

Figure 5.46 Jump Frequency Operation

- Note:**
1. The drive will use the active accel/decel time to pass through the specified dead band range, but will not allow continuous operation in that range.
 2. When setting more than one Jump frequency, make sure that the parameters do not overlap.

◆ d4: Frequency Reference Hold and Up/Down 2 Function

■ d4-01: Frequency Reference Hold Function Selection

Determines whether the frequency reference or the frequency bias (Up/Down 2) value is saved when the Stop command is entered or the power supply is shut down. This parameter is effective when either of the digital input functions listed below are used:

- Accel/decel ramp hold function (H1-□□ = A)
- Up/Down function (H1-□□ = 10 and 11)
- Up/Down 2 function (H1-□□ = 75 and 76)

No.	Parameter Name	Setting Range	Default
d4-01	Frequency Reference Hold Function Selection	0, 1	0

The operation depends on the function used with parameter d4-01.

Setting 0: Disabled

- Acceleration hold

The hold value will be reset to 0 Hz when the Stop command is entered or the drive power is switched off. The active frequency reference will be the value the drive uses when it restarts.

- Up/Down

The frequency reference value will be reset to 0 Hz when the Stop command is entered or the drive power is switched off. The drive will start from 0 Hz when it is restarted.

- Up/Down 2

The frequency bias is not saved when the Stop command is entered, or 5 s after the Up/Down 2 command has been released. The Up/Down 2 function will start with a bias of 0% when the drive is restarted.

Setting 1: Enabled

- Acceleration hold

The last hold value will be saved when the Run command or the drive power is switched off and the drive will use the saved value as the frequency reference when it restarts. Make sure to continuously enable the multi-function input terminal set for "Accel/decel ramp hold" (H1-□□ = A) or the hold value will be cleared when the power is switched on.

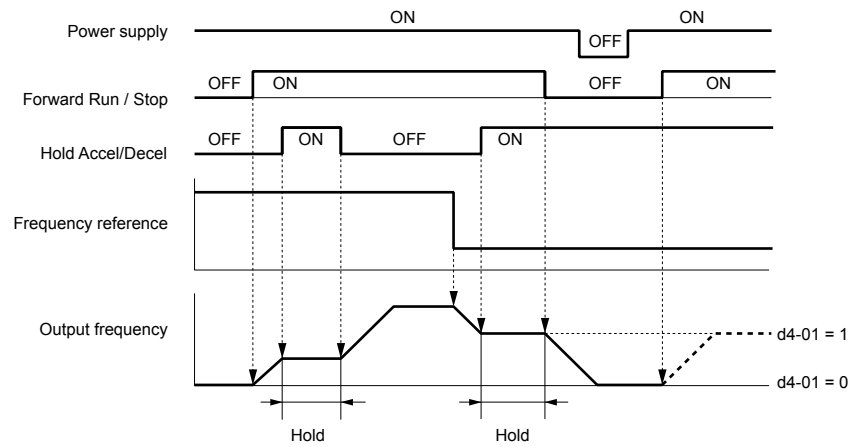

Figure 5.47 Frequency Reference Hold with Accel/Decel Hold Function

- Up/Down

The frequency reference value will be saved when the Run command or the drive power is switched off. The drive will use the frequency reference that was saved when it restarts.

- Up/Down 2 with frequency reference from digital operator

When a Run command is active and the Up/Down 2 command is released for longer than 5 s, the Up/Down 2 bias value is added to the frequency reference and then reset to 0. This new frequency reference is saved and will also be used to restart the drive after the power is cycled.

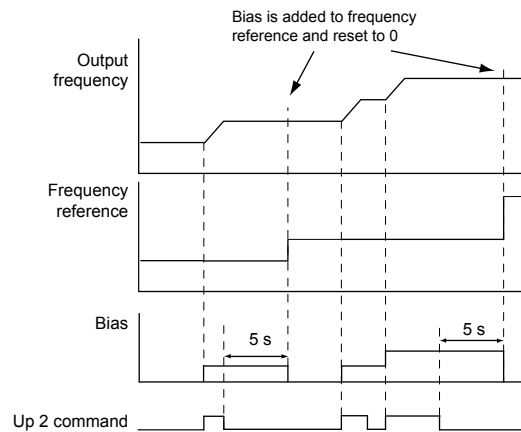

Figure 5.48 Up/Down 2 Example with Reference from Digital Operator and d4-01 = 1

- Up/Down 2 with frequency reference from input sources other than the digital operator

When a Run command is active and the Up/Down 2 command is released for longer than 5 s, the bias value will be saved in parameter d4-06. When restarting after the power is switched off, the drive will add the value saved in d4-06 as a bias to the frequency reference.

5.4 d: Reference Settings

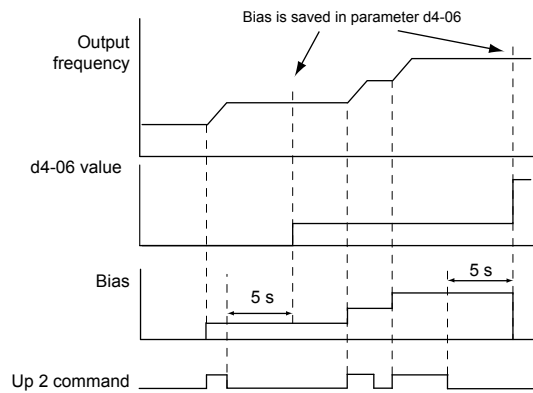

Figure 5.49 Up/Down 2 Example with Other Reference than Digital Operator and d4-01 = 1

Note: Set the limits for Up/Down 2 properly when using d4-01 = 1 in combination with the Up/Down 2 function. *Refer to d4-08: Frequency Reference Bias Upper Limit (Up/Down 2) on page 216 and Refer to d4-09: Frequency Reference Bias Lower Limit (Up/Down 2) on page 216* for details on the limit settings.

Clearing the Saved Value

Depending on which function is used, it is possible to clear the saved frequency reference value by:

- Releasing the input programmed for Acceleration hold.
- Setting an Up or Down command while no Run command is active.
- Resetting parameter d4-06 to zero. *Refer to d4-06: Frequency Reference Bias (Up/Down 2) on page 215* for details.

■ d4-03: Frequency Reference Bias Step (Up/Down 2)

Sets the bias added to or subtracted from the frequency reference by the Up/Down 2 function.

No.	Parameter Name	Setting Range	Default
d4-03	Frequency Reference Bias Step (Up/Down 2)	0.00 to 99.99 Hz	0.00 Hz

The operation depends on the set value:

Setting d4-03 = 0.00 Hz

While the Up 2 or Down 2 command is enabled, the bias value is increased or decreased using the accel/decel times determined by parameter d4-04.

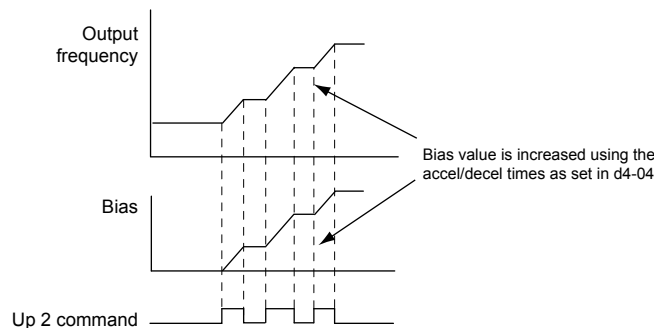

Figure 5.50 Up/Down 2 Bias when d4-03 = 0.00 Hz

Setting d4-03 ≠ 0.00 Hz

When an Up 2 or Down 2 command is enabled, the bias is increased or decreased in steps for the value set in d4-03. The frequency reference changes with the accel/decel times determined by parameter d4-04.

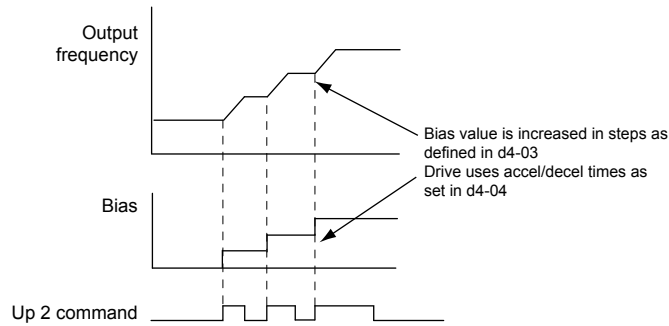

Figure 5.51 Up/Down 2 Bias when d4-03 > 0.00 Hz

■ d4-04: Frequency Reference Bias Accel/Decel (Up/Down 2)

Determines the accel/decel times used to increase or decrease the frequency reference or bias when using the Up/Down 2 function.

No.	Parameter Name	Setting Range	Default
d4-04	Frequency Reference Bias Accel/Decel (Up/Down 2)	0, 1	0

Setting 0: Current Accel/Decel Time

The drive uses the currently active accel/decel time.

Setting 1: Accel/Decel Time 4

The drive uses accel/decel time 4 set to parameters C1-07 and C1-08.

■ d4-05: Frequency Reference Bias Operation Mode Selection (Up/Down 2)

Determines if the bias value is held when the Up/Down 2 inputs are both released or both enabled. The parameter is effective only when parameter d4-03 is set to 0.00.

No.	Parameter Name	Setting Range	Default
d4-05	Frequency Reference Bias Operation Mode Selection (Up/Down 2)	0, 1	0

Setting 0: Hold Bias Value

The bias value will be held if no input Up 2 or Down 2 is active.

Setting 1: Reset Bias Value

The bias is reset to 0% when inputs Up 2 and Down 2 are both on or both off. The drive will use the accel/decel time as selected in d4-04 to accelerate or decelerate to the frequency reference value.

■ d4-06: Frequency Reference Bias (Up/Down 2)

Saves the frequency reference bias value set by the Up/Down 2 function as a percentage of the maximum output frequency. The function of this parameter depends on the Up/Down 2 function configuration. This parameter is not normally used when the digital operator sets the frequency reference.

- The value set to d4-06 will be applied during run, however the value is reset when the frequency reference changes (including multi-step references) and is disabled when d4-01 = 0 and the Run command is removed.
- When d4-01 = 0 and the frequency reference is set by a source other than the digital operator, the value set in d4-06 is added to or subtracted from the frequency reference.
- When d4-01 = 1 and the frequency reference is set by a source other than the digital operator, the bias value adjusted with the Up/Down 2 inputs is stored in d4-06 when 5 s have passed after releasing the Up 2 or Down 2 command. The frequency reference will return to the value without the Up/Down 2 command.

No.	Parameter Name	Setting Range	Default
d4-06	Frequency Reference Bias (Up/Down 2)	-99.9 to 100.0%	0.0%

Conditions that Reset or Disable d4-06

- The Up/Down 2 function has not been assigned to the multi-function terminals.
- The frequency reference source has been changed (including LOCAL/REMOTE or External reference 1/2 switch over by digital inputs).

5.4 d: Reference Settings

- d4-03 = 0 Hz, d4-05 = 1, and the Up/Down 2 commands are both open or both closed.
- Any changes to the maximum frequency set to E1-04.

■ d4-07: Analog Frequency Reference Fluctuation Limit (Up/Down 2)

Handles frequency reference changes while the Up 2 or Down 2 terminal is enabled. If the frequency reference changes for more than the level set to d4-07, then the bias value will be held, and the drive will accelerate or decelerate following the frequency reference. When the frequency reference is reached, the bias hold is released and the bias follows the Up/Down 2 input commands.

This parameter is applicable only if the frequency reference is set by an analog or pulse input.

No.	Parameter Name	Setting Range	Default
d4-07	Analog Frequency Reference Fluctuation Limit (Up/Down 2)	0.1 to 100.0%	1.0%

■ d4-08: Frequency Reference Bias Upper Limit (Up/Down 2)

Sets the upper limit of the Up/Down 2 bias (monitor U6-20) and the value that can be saved in parameter d4-06. Set this parameter to an appropriate value before using the Up/Down 2 function.

Note: When the frequency reference is set by the digital operator (b1-01 = 0) and d4-01 = 1, the bias value will be added to the frequency reference if no Up/Down 2 command is received for 5 s, and will be reset to 0 afterwards. From that point, the bias can be increased up to the limit set in d4-08 again.

No.	Parameter Name	Setting Range	Default
d4-08	Frequency Reference Bias Upper Limit (Up/Down 2)	0.0 to 100.0%	100.0%

■ d4-09: Frequency Reference Bias Lower Limit (Up/Down 2)

Sets the lower limit of the Up/Down 2 bias (monitor U6-20) and the value that can be saved in parameter d4-06. Set this parameter to an appropriate value before using the Up/Down 2 function.

Note: When the frequency reference is set by the digital operator (b1-01 = 0) and d4-01 = 1, the bias value will be added to the frequency reference if no Up/Down 2 command is received for 5 s, and will be reset to 0 afterwards. If the bias is increased using the Up 2 command, it cannot be reduced with a Down 2 command when the limit set in d4-09 is 0. Set a negative lower limit in d4-09 to allow speed reduction in this situation.

No.	Parameter Name	Setting Range	Default
d4-09	Frequency Reference Bias Lower Limit (Up/Down 2)	-99.9 to 0.0%	0.0%

■ d4-10: Up/Down Frequency Reference Limit Selection

Selects how the lower frequency limit is set when using the Up/Down function. [Refer to Setting 10, 11: Up/Down Function on page 250](#) for details on the Up/Down function in combination with frequency reference limits.

No.	Parameter Name	Setting Range	Default
d4-10	Up/Down Frequency Reference Limit Selection	0, 1	0

Setting 0: Lower Limit is Determined by d2-02 or Analog Input

The higher value between d2-02 and an analog input programmed for Frequency bias (A1, A2, A3) determines the lower frequency reference limit.

Note: When using the External Reference 1/2 (H1-□□ = 2) to switch between the Up/Down function and an analog input as the reference source, the analog value becomes the lower reference limit when the Up/Down command is active. Set d4-10 to 1 to make the Up/Down function independent of the analog input value.

Setting 1: Lower Limit is Determined by d2-02

Only parameter d2-02 sets the lower frequency reference limit.

◆ d5: Torque Control

Torque Control defines a setpoint for the motor torque and is available for CLV and CLV/PM (A1-02 = 3, 7).

Note: PM motor control modes are not available on 600 V class drives, models 5A□□□□.

■ Torque Control Operation

Torque control can be enabled either by setting parameter d5-01 to 1 or by setting digital input (H1-□□ = 71). *Figure 5.52* illustrates the working principle.

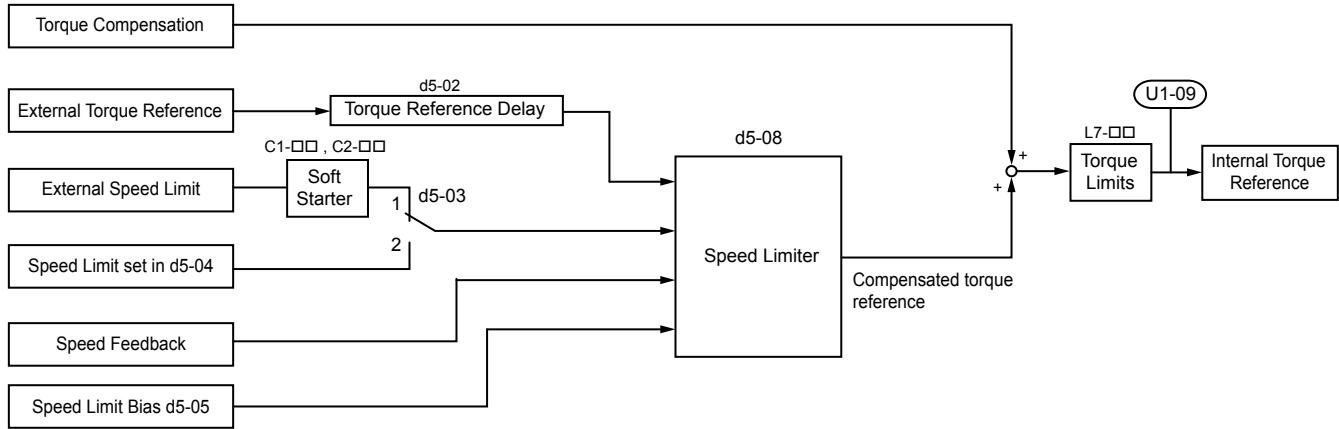

Figure 5.52 Torque Control Block Diagram

The externally input torque reference is the target value for the motor output torque. If the motor torque reference and the load torque are not in balance when in Torque Control, the motor accelerates or decelerates. To prevent operation beyond the speed limit, compensate the external torque reference value if the motor speed reaches the limit. The compensation value is calculated using the speed limit, speed feedback, and the speed limit bias.

If an external torque compensation value is input, it is added to the speed limit compensated torque reference value. The value calculated is limited by the L7-□□ settings, and is then used as the internal torque reference, which can be monitored in U1-09. The L7-□□ settings have highest priority. The motor cannot be operated with a higher torque than the L7-□□ settings even if the external torque reference value is increased.

■ Setting the Torque Reference, Speed Limit, and Torque Compensation Values

Torque Control Reference Sources

Set input values for Torque Control as explained in *Table 5.19*.

Table 5.19 Torque Control Input Value Selection

Input Value	Signal Source	Settings	Remarks
Torque Reference	Analog inputs A1/A2/A3	H3-02, H3-10, or H3-06 = 13 <I>	Match the input terminal signal level settings to the signal being used. <i>Refer to H3: Multi-Function Analog Inputs on page 268</i> for details on adjusting analog input signals.
	Analog Option	<ul style="list-style-type: none"> F2-01 = 0 H3-02, H3-10, or H3-06 = 13 <I> 	The F3-□□ settings become effective for the option board input terminals. Match the input terminal signal level settings to the signal being used. <i>Refer to H3: Multi-Function Analog Inputs on page 268</i> for details on adjusting analog input signals.

5.4 d: Reference Settings

Input Value	Signal Source	Settings	Remarks
Torque Reference	MEMOBUS Register 0004H	<ul style="list-style-type: none"> b1-01 = 2 Set Register 000FH, Bit 2 = 1 to enable Torque reference from register 0004H 	–
	Communications Option	<ul style="list-style-type: none"> b1-01 = 3 F6-06 = 1 Refer to the option card manual for details about setting the torque compensation value.	–
Speed Limit	Signal selected as frequency reference source	d5-03 = 1 The speed limit is taken from the input selected as frequency reference source in parameter b1-01 or b1-15. <1>	The settings in C1-□□ for accel/decel times and in C2-□□ for S-curves are applied to the speed limit value.
	Parameter d5-04	d5-03 = 2	–
Torque Compensation	Analog inputs A1/A2/A3	H3-02, H3-10, or H3-06 = 14 <1>	Match the input terminal signal level settings to the signal being used. Refer to H3: Multi-Function Analog Inputs on page 268 for details on adjusting analog input signals.
	Analog Option	<ul style="list-style-type: none"> F2-01 = 0 H3-02, H3-10, or H3-06 = 14 <1> 	The H3-□□ settings become effective for the option board input terminals. Match the input terminal signal level settings to the signal being used.
	MEMOBUS Register 0005H	<ul style="list-style-type: none"> b1-01 = 2 Set Register 000FH, bit 3 = 1 to enable the torque compensation setting by register 0005H 	–
	Communications Option	b1-01 = 3 Refer to the option card manual for details about setting the torque compensation value.	–

<1> Sets analog input terminals A1, A2, and A3 to supply the speed limit, torque reference, or torque compensation. Setting two analog inputs for the same function will trigger an oPE07 error (Multi-Function Analog Input Selection Error).

Input Value Polarity

The direction of the input values described above depends on the polarity of the Run command and the input value.

Table 5.20 Torque Control Signal Polarity

Run Command Direction	Input Value Polarity	Input Value Direction
Forward	+ (positive)	Forward direction
	- (negative)	Reverse direction
Reverse	+ (positive)	Reverse direction
	- (negative)	Forward direction

Example:

- With a Forward run command and a positive torque reference signal the internal torque reference will be positive, i.e., in the forward direction.
- With a Forward run command and a negative torque reference signal the internal torque reference will be negative, i.e., in the reverse direction.

When using analog inputs, negative input values can be generated by:

- applying negative voltage input signals.
- using positive analog input signals while setting the analog input bias to negative values so the input value can be negative.
- applying positive voltage input signals and using a digital input that is programmed for H1- □□ = 78.

When using MEMOBUS/Modbus communication or a communication option card, only positive input values can be set.

Independent of its input source, the polarity of the torque reference signal can be inverted using a digital input that is programmed for H1-□□ = 78. Use this function to input negative torque reference values when using MEMOBUS/Modbus or a communication option card.

Speed Limitation and Speed Limit Bias

The speed limit setting is read from the input selected in parameter d5-03. A bias can be added to this speed limit using parameter d5-05 while parameter d5-08 determines how the speed limit bias is applied. [Table 5.21](#) explains the relation between these settings.

Table 5.21 Speed Limit, Speed Bias and Speed Limit Priority Selection

Operating Conditions								
Run Command	Forward	Reverse	Forward	Reverse	Forward	Reverse	Forward	Reverse
Torque Reference Direction	Positive (Forward)	Reverse Positive (Forward)	Negative (Reverse)	Negative (Reverse)	Negative (Reverse)	Negative (Reverse)	Positive (Forward)	Positive (Forward)
Speed Limit Direction	Positive (Forward)	Negative (Reverse)	Negative (Reverse)	Positive (Forward)	Positive (Forward)	Negative (Reverse)	Negative (Reverse)	Positive (Forward)
Normal Operation Direction	Forward		Reverse		Forward		Reverse	
Bidirectional Speed Limit Bias (d5-08 = 0) </>								
Unidirectional Speed Limit Bias (d5-08 = 1) </>								
Application Example								

Parameter Details

5

<1> The value of delta n in the drawings depends on the ASR setting in parameters C5-□□.

Indicating Operation at the Speed Limit

Program a digital output to close when the drive operates at or beyond the speed limit (H2-□□ = 32). Use this output to notify a control device such as a PLC of abnormal operating conditions.

Switching Between Torque and Speed Control

Use a digital output to switch Torque Control and Speed Control (H1-□□ = 71). When switching from Speed Control to Torque Control, the torque limit becomes the torque reference and the speed reference becomes the speed limit. This change is reversed when switching back to Speed Control.

5.4 d: Reference Settings

If required by the application, set up a delay time using parameter d5-06. The reference values (torque reference/speed limit in Torque Control or speed reference/torque limit in Speed Control) are held during this switch delay time. Change the reference values from the controller within this delay time.

- Note:**
1. The switching delay time d5-06 is not applied when the Stop command is entered. Here the operation switches immediately to speed control and the drive decelerates to stop at the torque limit.
 2. Set d5-01 to 0 when switching between Torque Control and Speed Control. An oPE15 alarm will be triggered if parameter d5-01 is set to 1 while H1-□□ is set to 71 at the same time.

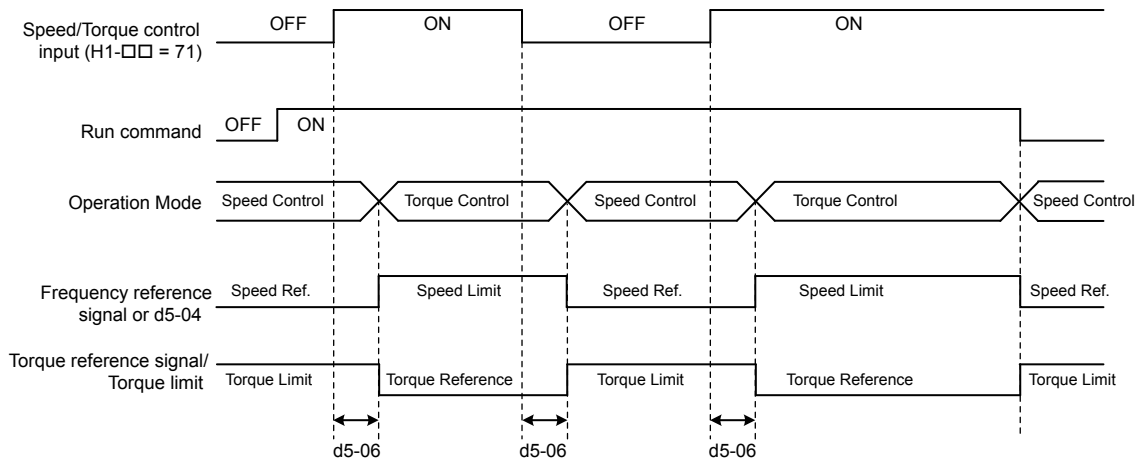

Figure 5.53 Speed/Torque Control Switching Time

■ d5-01: Torque Control Selection

No.	Parameter Name	Setting Range	Default
d5-01	Torque Control Selection	0, 1	0

Setting 0: Disabled

Speed Control will be active. Also use this setting when H1-□□ = 71 (Speed/Torque Control Switch).

Setting 1: Enabled

Torque Control is always enabled.

■ d5-02: Torque Reference Delay Time

Apply a filter with the time constant set to parameter d5-02 to the torque reference signal to eliminate oscillation resulting from an unstable torque reference signal. A higher filter time stabilizes control while reducing the responsiveness.

No.	Parameter Name	Setting Range	Default
d5-02	Torque Reference Delay Time	0 to 1000 ms	0 ms

■ d5-03: Speed Limit Selection

Determines how the speed limit is set.

No.	Parameter Name	Setting Range	Default
d5-03	Speed Limit Selection	1 or 2	1

Setting 1: Frequency Reference Input

The frequency reference value at the active reference source (digital operator, External reference 1 or External reference 2) will be used as speed limit. Note that in this case all settings for accel/decel times (C1-01 to C1-08) and S-curves (C2-01 to C2-04) will apply for the speed limit.

Setting 2: d5-04

The speed limit is set by parameter d5-04.

■ d5-04: Speed Limit

Sets the speed limit during torque control if parameter d5-03 is set to 2. *Refer to Speed Limitation and Speed Limit Bias on page 219.*

No.	Parameter Name	Setting Range	Default
d5-04	Speed Limit	-120 to 120%	0%

■ d5-05: Speed Limit Bias

Applies a bias set as a percentage of the maximum output frequency to the speed limit value. *Refer to Speed Limitation and Speed Limit Bias on page 219.*

No.	Parameter Name	Setting Range	Default
d5-05	Speed Limit Bias	0 to 120%	10%

■ d5-06: Speed/Torque Control Switchover Time

Sets the delay time for switching between Speed Control and Torque Control.

No.	Parameter Name	Setting Range	Default
d5-06	Speed/Torque Control Switchover Time	0 to 1000 ms	0 ms

■ d5-08: Unidirectional Speed Limit Bias

Selects how the speed limit bias is applied.

No.	Parameter Name	Setting Range	Default
d5-08	Unidirectional Speed Limit Bias	0, 1	1

Setting 0: Disabled

The speed limit bias is applied in the speed limit direction and the opposite direction.

Setting 1: Enabled

The speed limit bias is applied in the opposite direction of the speed limit only.

◆ d6: Field Weakening and Field Forcing**Field Weakening**

The Field Weakening function reduces the output voltage to a predefined level to reduce the energy consumption of the motor. To activate the Field Weakening function, use a digital input programmed for H1-□□ = 63. Only use Field Weakening with a known and unchanging light load condition. Use the Energy Saving function (b8-□□ parameters) when Energy Saving for various different load conditions is required.

Field Forcing

The Field Forcing function compensates the delaying influence of the motor time constant when changing the excitation current reference and improves motor responsiveness. Field Forcing is ineffective during DC Injection Braking.

■ d6-01: Field Weakening Level

Sets the level to which the output voltage is reduced when Field Weakening is activated. Set as percentage of the maximum output voltage.

No.	Parameter Name	Setting Range	Default
d6-01	Field Weakening Level	0 to 100%	80%

■ d6-02: Field Weakening Frequency Limit

Sets the minimum output frequency at which field weakening can be activated. Field Weakening cannot be activated for frequencies below d6-02.

No.	Parameter Name	Setting Range	Default
d6-02	Field Weakening Frequency Limit	0 to 400.0 Hz	0.0 Hz

5.4 d: Reference Settings

■ d6-03: Field Forcing Selection

Enables or disables the Field Forcing function.

No.	Parameter Name	Setting Range	Default
d6-03	Field Forcing Selection	0, 1	0

Setting 0: Disabled

Setting 1: Enabled

■ d6-06: Field Forcing Limit

Sets the maximum level at which the Field Forcing function can boost the excitation current reference. The value is set as a percentage of the motor no load current. This parameter does not normally need to be changed.

No.	Parameter Name	Setting Range	Default
d6-06	Field Forcing Limit	100 to 400%	400%

◆ d7: Offset Frequency

■ d7-01 to d7-03: Offset Frequency 1 to 3

Three different offset values can be added to the frequency reference. They can be selected using digital inputs programmed for Offset frequency 1, 2, and 3 (H1-□□ = 44, 45, 46). The selected offset values are added together if multiple inputs are closed simultaneously. The value is set as a percentage of the Maximum Output Frequency.

Note: This function can replace the “Trim Control” function (H1-□□ = 1C, 1D) of older Yaskawa drives.

No.	Parameter Name	Setting Range	Default
d7-01	Offset Frequency 1	-100.0 to 100.0%	0%
d7-02	Offset Frequency 2	-100.0 to 100.0%	0%
d7-03	Offset Frequency 3	-100.0 to 100.0%	0%

Figure 5.54 illustrates the Offset frequency function.

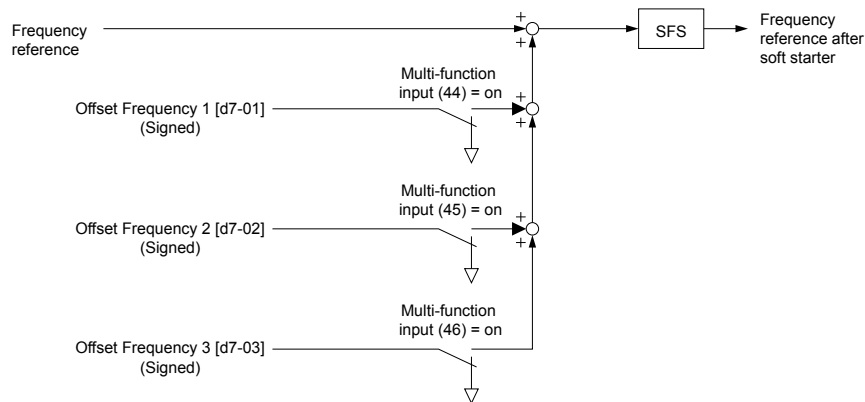

Figure 5.54 Offset Frequency Operation

5.5 E: Motor Parameters

E parameters cover V/f pattern and motor data settings.

◆ E1: V/f Pattern for Motor 1

■ E1-01: Input Voltage Setting

Adjusts the levels of some protective features of the drive (overvoltage, Stall Prevention, etc.). Set this parameter to the nominal voltage of the AC power supply.

NOTICE: Set parameter E1-01 to match the input voltage of the drive. Drive input voltage (not motor voltage) must be set in E1-01 for the protective features to function properly. Failure to set the correct drive input voltage will result in improper drive operation.

No.	Parameter Name	Setting Range	Default
E1-01	Input Voltage Setting	155 to 255 V <1>	230 V <1>

<1> Values shown are specific to 200 V class drives. Double the value for 400 V class drives. Multiply the value by 2.875 for 600 V class drives.

E1-01 Related Values

The input voltage setting determines the overvoltage and undervoltage detection levels, the operation levels of the braking transistor, the KEB function, and the overvoltage suppression function.

Voltage	Setting Value of E1-01	ov Detection Level/Dynamic Braking Transistor Detection Level <1> (rr Detection Level)	(Approximate Values)		
			Uv Detection Level (L2-05)	Desired DC Bus Voltage during KEB (L2-11)	ov Suppression / Stall Prevention Level (L3-17)
200 V Class	All settings	410 V / 394 V	190 V	260 V	375 V
400 V Class	setting ≥ 400 V	820 V / 788 V	380 V	500 V	750 V
	setting < 400 V	820 V / 788 V	350 V	460 V	750 V
600 V Class	All settings	1178 V / 1132 V	475 V	635 V	930 V

<1> The braking transistor operation levels are valid for the drive internal braking transistor. When using a CDBR braking unit, refer to instruction manual TOBPC72060000 or TOBPC72060001.

■ V/f Pattern Settings (E1-03)

The drive uses a V/f pattern to adjust the output voltage relative to the frequency reference. There are 15 different predefined V/f patterns (setting 0 to E) from which to select, each with varying voltage profiles, saturation levels (frequency at which maximum voltage is reached), and maximum frequencies. Additionally, one custom V/f pattern is available (setting F) that requires the user to create the pattern using parameters E1-04 through E1-10.

■ E1-03: V/f Pattern Selection

Selects the V/f pattern for the drive and motor from 15 predefined patterns or creates a custom V/f pattern.

No.	Parameter Name	Setting Range	Default
E1-03	V/f Pattern Selection	0 to F <2>	F <1>

<1> Parameter is not reset to the default value when the drive is initialized using A1-03.

<2> Settings 0 through E are not available when A1-02 = 2, 3, 5, 6, or 7.

Setting a Predefined V/f Pattern (Setting 0 to E)

Choose the V/f pattern that best meets the application demands from [Table 5.22](#). These settings are available only in V/f Control modes. Set the correct value to E1-03. Parameters E1-04 to E1-13 can only be monitored, not changed.

- Note:**
- Setting an improper V/f pattern may result in low motor torque or increased current due to overexcitation.
 - Drive initialization does not reset parameter E1-03.

5.5 E: Motor Parameters

Table 5.22 Predefined V/f Patterns

Setting	Specification	Characteristic	Application
0	50 Hz	Constant torque	For general purpose applications. Torque remains constant regardless of changes to speed.
1	60 Hz		
2	60 Hz (with 50 Hz base)		
3	72 Hz (with 60 Hz base)		
4	50 Hz, Heavy Duty 2	Variable torque	For fans, pumps, and other applications where the required torque changes as a function of the speed.
5	50 Hz, Heavy Duty 1		
6	50 Hz, Heavy Duty 1		
7	50 Hz, Heavy Duty 2		
8	50 Hz, mid starting torque	High starting torque	Select high starting torque when: <ul style="list-style-type: none"> • Wiring between the drive and motor exceeds 150 m. • A large amount of starting torque is required. • An AC reactor is installed.
9	50 Hz, high starting torque		
A	60 Hz, mid starting torque		
B	60 Hz, high starting torque		
C	90 Hz (with 60 Hz base)	Constant output	Output voltage is constant when operating at greater than 60 Hz.
D	120 Hz (with 60 Hz base)		
E	180 Hz (with 60 Hz base)		
F </>	60 Hz		

</> Setting F enables a custom V/f pattern by changing parameters E1-04 to E1-13. When the drive is shipped, the default values for parameters E1-04 to E1-13 are the same as those of setting 1.

The following tables show details on predefined V/f patterns.

Predefined V/f Patterns for Models 2A0004 to 2A0021, 4A0002 to 4A0011, and 5A0003 to 5A0009

The values in the following graphs are specific to 200 V class drives. Double the values for 400 V class drives. Multiply the values by 2.875 for 600 V drives.

Table 5.23 Constant Torque Characteristics, Settings 0 to 3

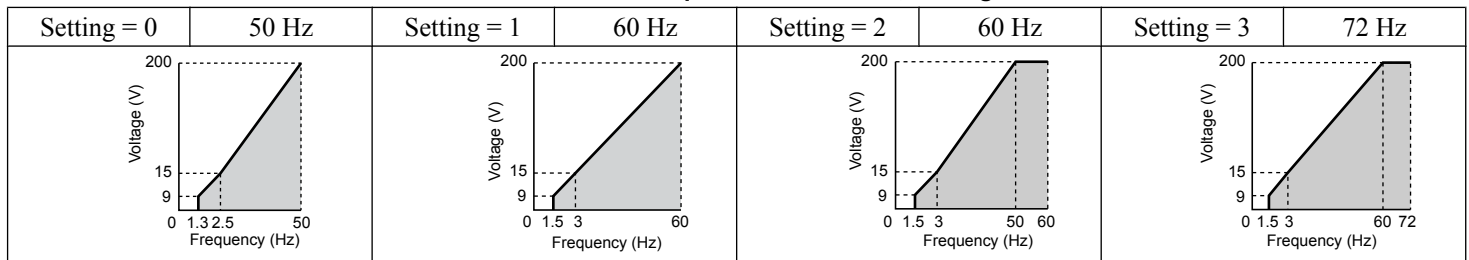

Table 5.24 Derated Torque Characteristics, Settings 4 to 7

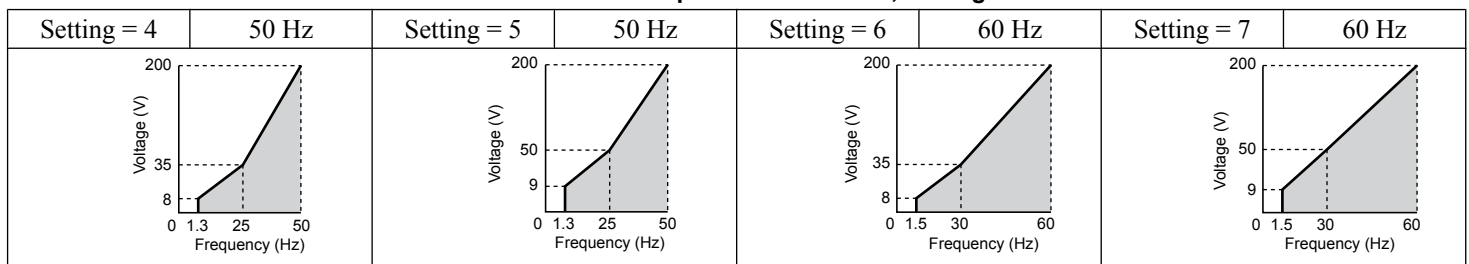

Table 5.25 High Starting Torque, Settings 8 to B

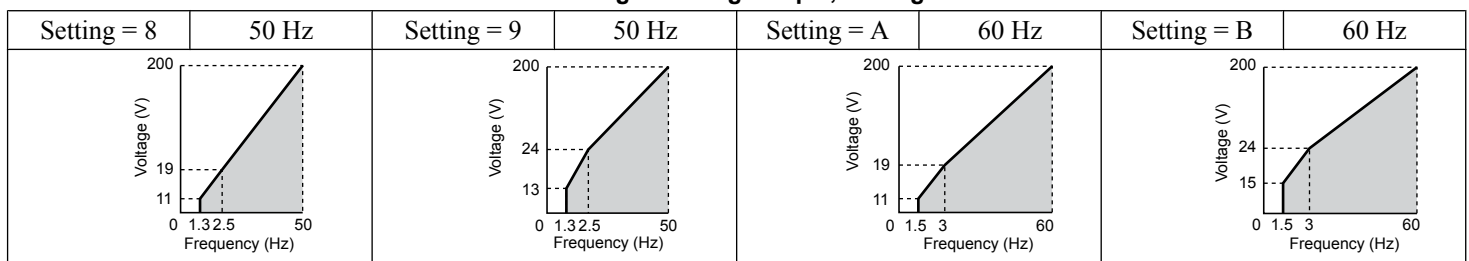
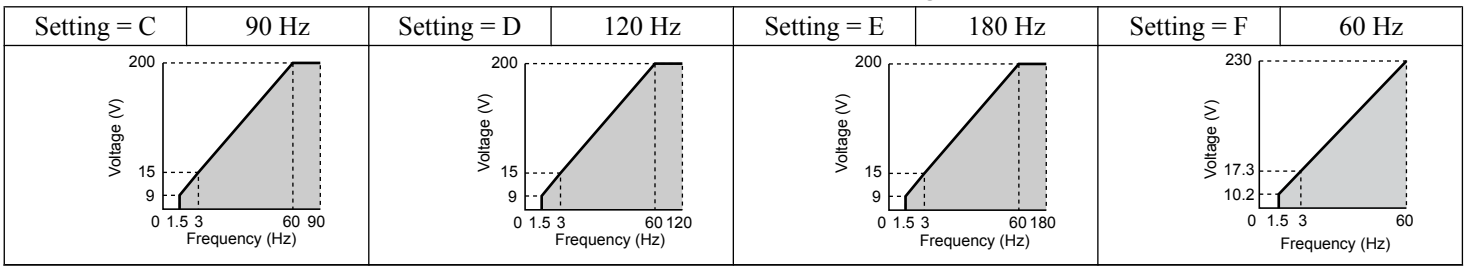

Table 5.26 Rated Output Operation, Settings C to F



Predefined V/f Patterns for Models 2A0030 to 2A0211, 4A0018 to 4A0103, and 5A0011 to 5A0077

The values in the following graphs are specific to 200 V class drives. Double the values for 400 V class drives. Multiply the values by 2.875 for 600 V class drives.

Table 5.27 Rated Torque Characteristics, Settings 0 to 3

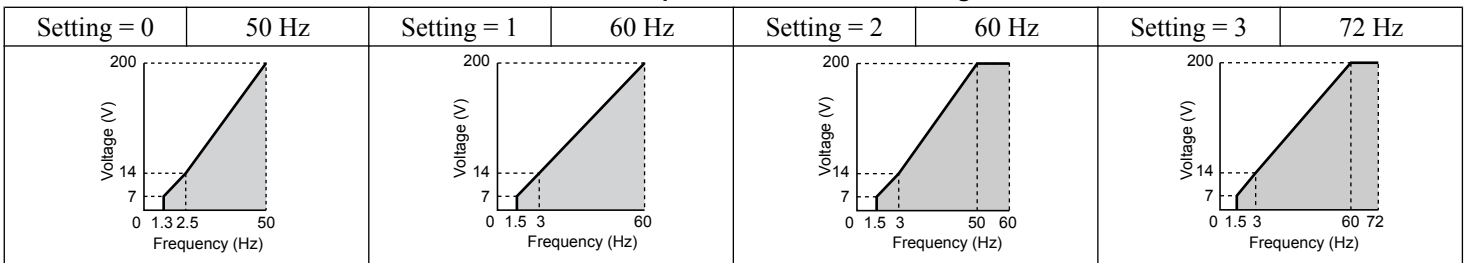

Table 5.28 Derated Torque Characteristics, Settings 4 to 7

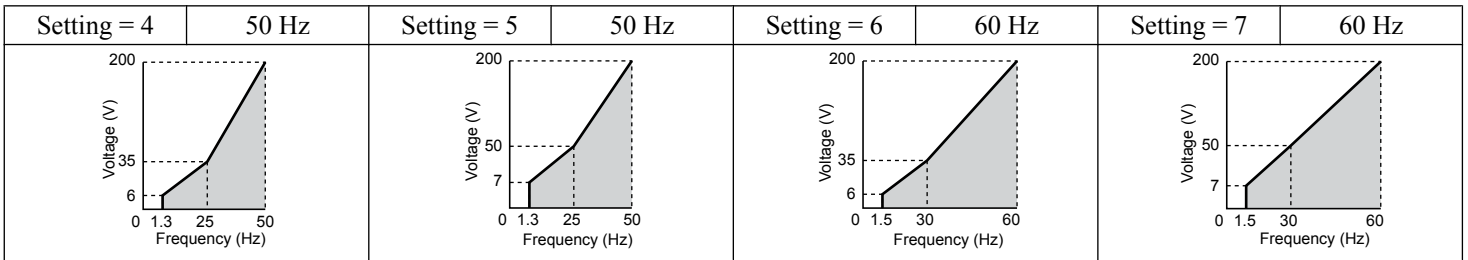

Table 5.29 High Starting Torque, Settings 8 to B

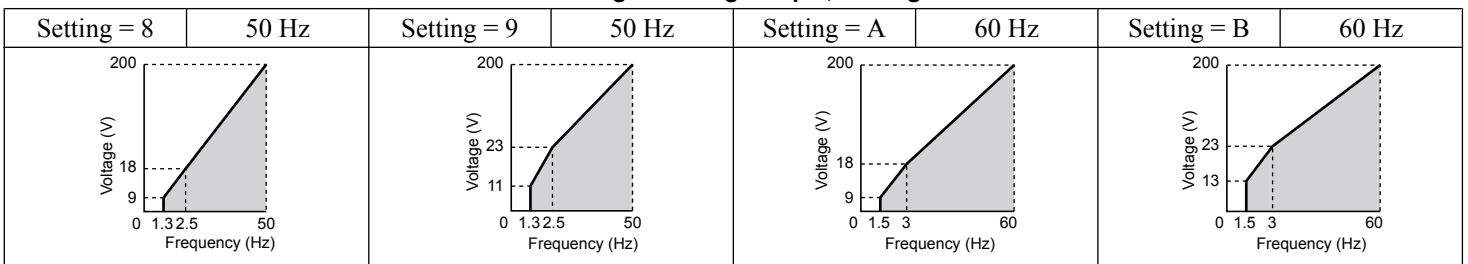
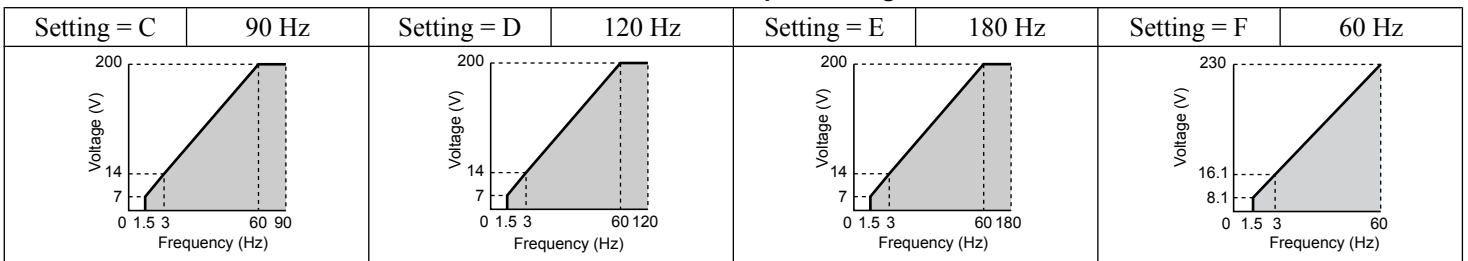

Table 5.30 Constant Output, Settings C to F



Predefined V/f Patterns for Models 2A0250 to 2A0415, 4A0139 to 4A1200, and 5A0099 to 5A0242

The values in the following graphs are specific to 200 V class drives. Double the values for 400 V class drives. Multiply the values by 2.875 for 600 V class drives.

5.5 E: Motor Parameters

Table 5.31 Rated Torque Characteristics, Settings 0 to 3

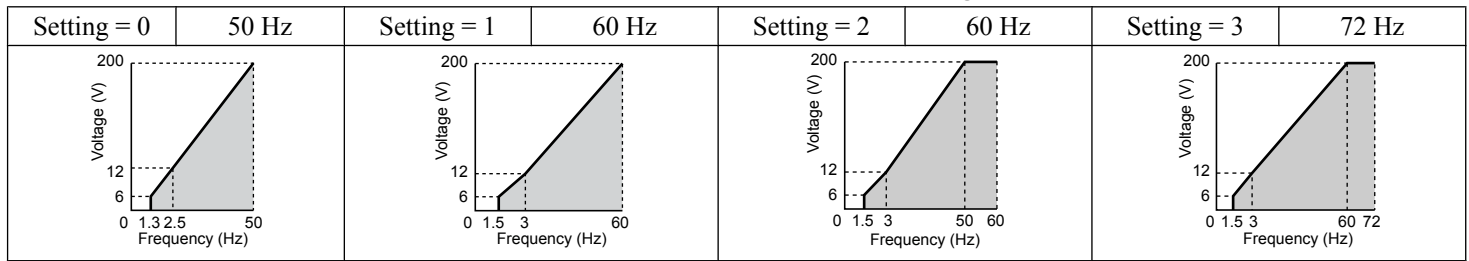

Table 5.32 Derated Torque Characteristics, Settings 4 to 7

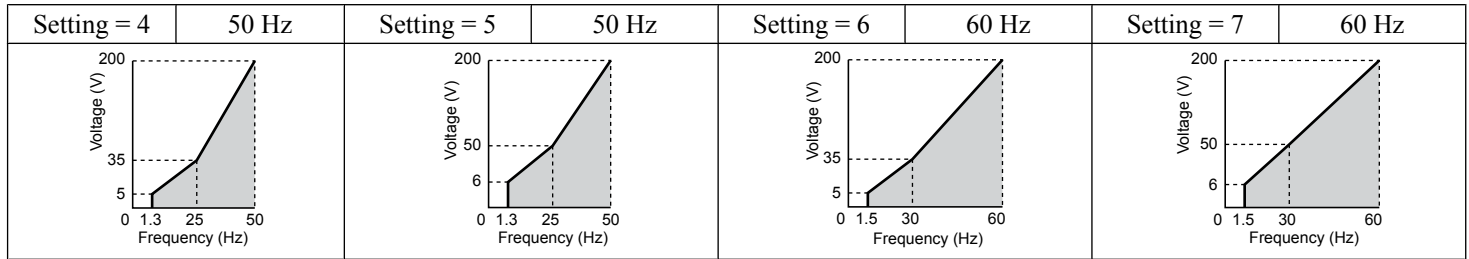

Table 5.33 High Starting Torque, Settings 8 to B

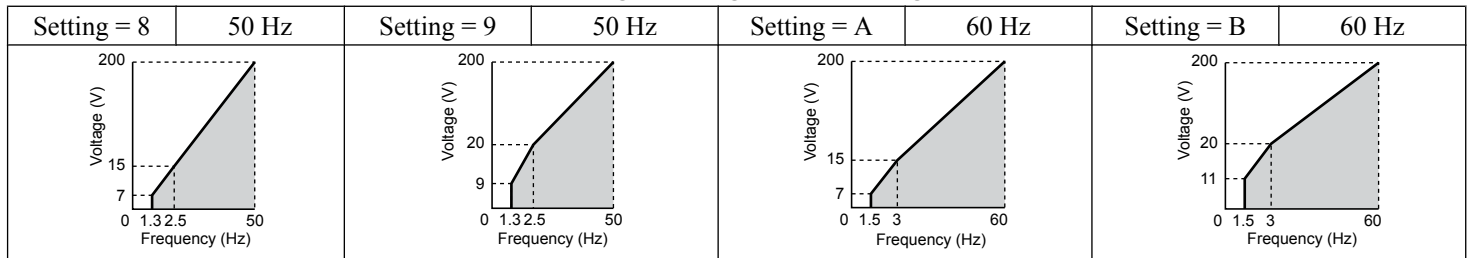
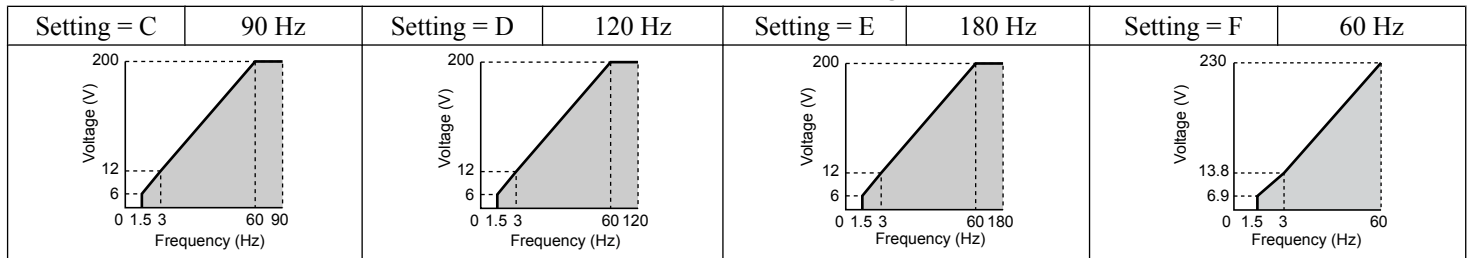

Table 5.34 Constant Output, Settings C to F



Setting a Custom V/f Pattern (Setting F: Default)

Setting parameter E1-03 to F allows the user to set up a custom V/f pattern by changing parameters E1-04 to E1-13.

When initialized, the default values for parameters E1-04 to E1-13 will be equal to Predefined V/f pattern 1.

■ V/f Pattern Settings E1-04 to E1-13

If E1-03 is set to a preset V/f pattern (i.e., a value other than F), the user can monitor the V/f pattern in parameters E1-04 through E1-13. To create a new V/f pattern, set E1-03 to F. [Refer to V/f Pattern on page 227](#) for an example custom V/f pattern.

Note: Certain E1-□□ parameters might not be visible depending on the control mode. [Refer to Parameter List on page 489](#) for details.

No.	Parameter Name	Setting Range	Default
E1-04	Maximum Output Frequency	40.0 to 400.0 Hz <F>	<F> <F>
E1-05	Maximum Voltage	0.0 to 255.0 V <F>	<F>
E1-06	Base Frequency	0.0 to [E1-04]	<F> <F>
E1-07	Middle Output Frequency	0.0 to [E1-04]	<F>
E1-08	Middle Output Frequency Voltage	0.0 to 255.0 V <F>	<F>
E1-09	Minimum Output Frequency	0.0 to [E1-04] <F>	<F> <F>

No.	Parameter Name	Setting Range	Default
E1-10	Minimum Output Frequency Voltage	0.0 to 255.0 V <>	<>
E1-11	Middle Output Frequency 2	0.0 to [E1-04]	0.0 Hz <6>
E1-12	Middle Output Frequency Voltage 2	0.0 to 255.0 V <>	0.0 V <> <6>
E1-13	Base Voltage	0.0 to 255.0 V <>	0.0 V <> <7>

- <1> Default setting is determined by E5-01 in OLV/PM. The setting range is 0.0 to 400.0 Hz when E5-01 = FFFFH.
- <2> Default setting is determined by the control mode.
- <3> When using PM motors, the default setting is determined by the motor code set to E5-01.
- <4> Values shown are specific to 200 V class drives. Double the value for 400 V class drives. Multiply the value by 2.875 for 600 V class drives.
- <5> The drive changes these settings when Auto-Tuning is performed (Rotational Auto-Tuning, Stationary Auto-Tuning 1, 2).
- <6> Parameter ignored when E1-11 and E1-12 are set to 0.0.
- <7> E1-13 and E1-05 are set to the same value when Auto-Tuning is performed.

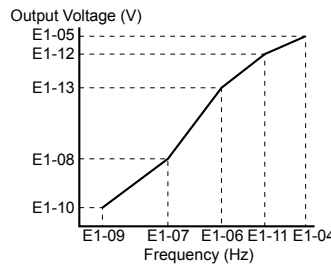

Figure 5.55 V/f Pattern

- Note:**
1. The following condition must be true when setting up the V/f pattern: $E1-09 \leq E1-07 < E1-06 \leq E1-11 \leq E1-04$
 2. To make the V/f pattern a straight line below E1-06, set E1-09 equal to E1-07. In this case the E1-08 setting is disregarded.
 3. E1-03 is unaffected when the drive is initialized, but E1-04 through E1-13 return to their default values.
 4. Only use E1-11, E1-12, and E1-13 to fine-tune the V/f pattern in the constant output range. These parameters rarely need to be changed.

◆ E2: Motor 1 Parameters

These parameters contain the motor data needed for motor 1. Performing Auto-Tuning (including Rotational Auto-Tuning and Stationary Auto-Tuning 1 and 2) automatically sets these parameters. *Refer to Auto-Tuning Fault Detection on page 379* for details if Auto-Tuning cannot be performed.

- Note:** The function for switching between two motors cannot be used with a PM motor. E2-□□ parameters are hidden when a PM motor control mode is selected (A1-02 = 5, 6, or 7).

■ E2-01: Motor Rated Current

Provides motor control, protects the motor, and calculates torque limits. Set E2-01 to the full load amps (FLA) stamped on the motor nameplate. If Auto-Tuning completes successfully, the value entered to T1-04 will automatically be saved to E2-01.

No.	Parameter Name	Setting Range	Default
E2-01	Motor Rated Current	10% to 200% of the drive rated current	Determined by C6-01 and o2-04

- Note:**
1. The number of decimal places in the parameter value depends on the drive model and the ND/HD selection in parameter C6-01. This value has two decimal places (0.01 A) if the drive is set for a maximum applicable motor capacity up to and including 11 kW, and one decimal place (0.1 A) if the maximum applicable motor capacity is higher than 11 kW. *Refer to Power Ratings on page 463* for details.
 2. An oPE02 error will occur if the motor rated current in E2-01 is set lower than the motor no-load current in E2-03. Set E2-03 correctly to prevent this error.

■ E2-02: Motor Rated Slip

Sets the motor rated slip in Hz to provide motor control, protect the motor, and calculate torque limits. This value is automatically set during Auto-Tuning (Rotational Auto-Tuning, Stationary Auto-Tuning 1 and 2).

No.	Parameter Name	Setting Range	Default
E2-02	Motor Rated Slip	0.00 to 20.00 Hz	Determined by C6-01 and o2-04

5.5 E: Motor Parameters

If Auto-Tuning cannot be performed, calculate the motor rated slip using the information written on the motor nameplate and the formula below:

$$E2-02 = f - (n \times p)/120$$

(f: rated frequency (Hz), n: rated motor speed (r/min), p: number of motor poles)

■ E2-03: Motor No-Load Current

Set the no-load current for the motor in amperes when operating at the rated frequency and the no-load voltage. The drive sets E2-03 during the Auto-Tuning process (Rotational Auto-Tuning and Stationary Auto-Tuning 1, 2). The motor no-load current listed in the motor test report can also be entered to E2-03 manually. Contact the motor manufacturer to receive a copy of the motor test report.

No.	Parameter Name	Setting Range	Default
E2-03	Motor No-Load Current	0 to [E2-01] (unit: 0.01 A)	Determined by C6-01 and o2-04

Note: The number of decimal places in the parameter value depends on the drive model and the ND/HD selection in parameter C6-01. This value has two decimal places (0.01 A) if the drive is set for a maximum applicable motor capacity up to and including 11 kW, and one decimal place (0.1 A) if the maximum applicable motor capacity is higher than 11 kW. [Refer to Power Ratings on page 463](#) for details.

■ E2-04: Number of Motor Poles

Set the number of motor poles to E2-04. If Auto-Tuning completes successfully, the value entered to T1-06 will automatically be saved to E2-04.

No.	Parameter Name	Setting Range	Default
E2-04	Number of Motor Poles	2 to 48	4

■ E2-05: Motor Line-to-Line Resistance

Sets the line-to-line resistance of the motor stator winding. If Auto-Tuning completes successfully, this value is automatically calculated. Enter this value as line-to-line and not for each motor phase.

If Auto-Tuning is not possible, contact the motor manufacturer to find out the line-to-line resistance or measure it manually. When using the manufacturer motor test report, calculate E2-05 by one of the formulas below:

- E-type insulation: Multiply 0.92 times the resistance value (Ω) listed on the test report at 75 °C.
- B-type insulation: Multiply 0.92 times the resistance value (Ω) listed on the test report at 75 °C.
- F-type insulation: Multiply 0.87 times the resistance value (Ω) listed on the test report at 115 °C.

No.	Parameter Name	Setting Range	Default
E2-05	Motor Line-to-Line Resistance	0.000 to 65000 m Ω <I>	Determined by C6-01 and o2-04

<I> Units are expressed in m Ω for models 4A0930 and 4A1200.

■ E2-06: Motor Leakage Inductance

Sets the voltage drop due to motor leakage inductance as a percentage of motor rated voltage. This value is automatically set during Auto-Tuning (Rotational Auto-Tuning, Stationary Auto-Tuning 1, 2).

No.	Parameter Name	Setting Range	Default
E2-06	Motor Leakage Inductance	0.0 to 40.0%	Determined by C6-01 and o2-04

■ E2-07: Motor Iron-Core Saturation Coefficient 1

Sets the motor iron saturation coefficient at 50% of the magnetic flux. If Rotational Auto-Tuning completes successfully, then this value is automatically calculated and set to E2-07. This coefficient is used when operating with constant output.

No.	Parameter Name	Setting Range	Default
E2-07	Motor Iron-Core Saturation Coefficient 1	0.00 to 0.50	0.50

■ E2-08: Motor Iron-Core Saturation Coefficient 2

Sets the motor iron saturation coefficient at 75% of the magnetic flux. If Rotational Auto-Tuning completes successfully, then this value is automatically calculated and set to E2-08. This coefficient is used when operating with constant output.

No.	Parameter Name	Setting Range	Default
E2-08	Motor Iron-Core Saturation Coefficient 2	E2-07 to 0.75	0.75

■ E2-09: Motor Mechanical Loss

Sets the motor mechanical loss as a percentage of motor rated power (kW) capacity.

Adjust this setting in the following circumstances:

- When there is a large amount of torque loss due to motor bearing friction.
- When there is a large amount of torque loss in a fan or pump application.

The setting for the mechanical loss is added to the torque.

No.	Parameter Name	Setting Range	Default
E2-09	Motor Mechanical Loss	0.0 to 10.0%	0.0%

■ E2-10: Motor Iron Loss for Torque Compensation

Sets the motor iron loss in watts.

No.	Parameter Name	Setting Range	Default
E2-10	Motor Iron Loss for Torque Compensation	0 to 65535 W	Determined by C6-01 and o2-04

■ E2-11: Motor Rated Power

Sets the motor rated power in kW. If Auto-Tuning completes successfully, the value entered to T1-02 will automatically be saved to E2-11.

No.	Parameter Name	Setting Range	Default
E2-11	Motor Rated Power	0.00 to 650.00 kW	Determined by C6-01 and o2-04

Note: The display resolution depends on the rated output power of the drive after setting the Drive Duty in parameter C6-01. Drive models 2A0004 to 4A0515 display this value in units of 0.01 kW (two decimal places). Drive models 4A0675 to 4A1200 display this value in units of 0.1 kW (one decimal place). *Refer to Nameplate on page 35* for details.

■ Setting Motor Parameters Manually

Follow the instructions below when setting motor-related parameters manually instead of Auto-Tuning. Refer to the motor test report included with the motor to ensure the correct data is entered into the drive.

Set the Motor Rated Current

Enter the motor rated current listed on the nameplate of the motor to E2-01.

Set the Motor Rated Slip

Calculate the motor rated slip using the base speed listed on the motor nameplate. Refer to the formula below, then enter that value to E2-02.

Motor rated slip = rated frequency [Hz] – base speed [r/min] × (no. of motor poles) / 120

Set the No-Load Current

Enter the no-load current at rated frequency and rated voltage to E2-03. This information is not usually listed on the nameplate. Contact the motor manufacturer if the data cannot be found.

The default setting of the no-load current is for performance with a 4-pole Yaskawa motor.

Set the Number of Motor Poles

Only required in V/f Control with PG and Closed Loop Vector Control. Enter the number of motor poles as indicated on motor nameplate.

Set the Line-to-Line Resistance

E2-05 is normally set during Auto-Tuning. If Auto-Tuning cannot be performed, contact the motor manufacturer to determine the correct resistance between motor lines. The motor test report can also be used to calculate this value using the formulas below:

- E-type insulation: Multiply 0.92 times the resistance value (Ω) listed on the test report at 75 °C.
- B-type insulation: Multiply 0.92 times the resistance value (Ω) listed on the test report at 75 °C.

5.5 E: Motor Parameters

- F-type insulation: Multiply 0.87 times the resistance value (Ω) listed on the test report at 115 °C.

Set the Motor Leakage Inductance

The motor leakage inductance set to E2-06 determines the amount of voltage drop relative to the motor rated voltage. Enter this value for motors with a low degree of inductance, such as high-speed motors. This information is usually not listed on the motor nameplate. Contact the motor manufacturer if the data cannot be found.

Set the Motor Iron-Core Saturation Coefficient 1, 2

E2-07 and E2-08 are set when Auto-Tuning is performed.

Set the Motor Mechanical Loss

Only required in Closed Loop Vector Control. The drive compensates for the degree of mechanical loss with torque compensation. Although E2-09 rarely needs to be changed, adjustment may be necessary in the following circumstances:

- When there is a large amount of torque loss due to motor bearing friction.
- When there is a large amount of torque loss in a fan or pump application.

Set the Motor Iron Loss for Torque Compensation

Only required when using V/f Control. Enter this value in watts to E2-10. The drive uses this setting to improve the precision of torque compensation.

◆ E3: V/f Pattern for Motor 2

These parameters set the V/f pattern used for motor 2. [Refer to Setting 16: Motor 2 Selection on page 252](#) for details on switching motors.

Note: The function for switching between two motors cannot be used with a PM motor. E3-□□ parameters are hidden when a PM motor control mode is selected (A1-02 = 5, 6, or 7).

■ E3-01: Motor 2 Control Mode Selection

Selects the control mode for motor 2. A control mode for PM motors cannot be selected for motor 2.

No.	Parameter Name	Setting Range	Default
E3-01	Motor 2 Control Mode Selection	0 to 3	0

Note: L1-01 determines protection from motor overload (oL1) in motor 2 and motor 1.

Setting 0: V/f Control

Setting 1: V/f Control with PG

Setting 2: Open Loop Vector Control

Setting 3: Closed Loop Vector Control

■ E3-04 to E3-13

Parameters E3-04 through E3-13 set up the V/f pattern used for motor 2 as shown in [Figure 5.56](#).

Note: Certain E3-□□ parameters might not be visible depending on the control mode. [Refer to Parameter List on page 489](#) for details.

No.	Parameter Name	Setting Range	Default
E3-04	Motor 2 Max Output Frequency	40.0 to 400.0 Hz	<2>
E3-05	Motor 2 Max Voltage	0.0 to 255.0 V <1>	<1> <2>
E3-06	Motor 2 Base Frequency	0.0 to [E3-04]	<2>
E3-07	Motor 2 Mid Output Frequency	0.0 to [E3-04]	<2>
E3-08	Motor 2 Mid Output Frequency Voltage	0.0 to 255.0 V <1>	<1> <2>
E3-09	Motor 2 Minimum Output Frequency	0.0 to [E3-04]	<2>
E3-10	Motor 2 Minimum Output Frequency Voltage	0.0 to 255.0 V <1>	<1> <2>
E3-11	Motor 2 Mid Output Frequency 2	0.0 to [E3-04]	0.0 Hz <4>
E3-12	Motor 2 Mid Output Frequency Voltage 2	0.0 to 255.0 V <1>	0.0 V <3> <4>
E3-13	Motor 2 Base Voltage	0.0 to 255.0 V <1>	0.0 V <3>

<1> Values shown here are specific to 200 V class drives. Double the value for 400 V class drives. Multiply the value by 2.875 for 600 V class drives.

- <2> Default setting is determined by the control mode selected for motor 2 (E3-01).
- <3> The drive sets this value when Auto-Tuning is performed (Rotational Auto-Tuning and Stationary Auto-Tuning 1, 2).
- <4> Parameter ignored when E3-11 and E3-12 are set to 0.0.

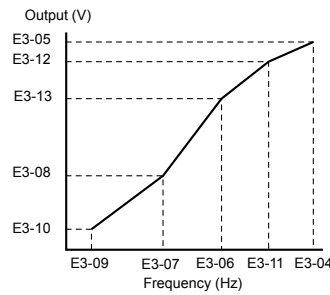

Figure 5.56 V/f Pattern for Motor 2

- Note:**
1. The following conditions must be true when setting up the V/f pattern: $E3-09 \leq E3-07 < E3-06 \leq E3-11 \leq E3-04$
 2. To make the V/f pattern a straight line at a frequency lower than E3-06, set E3-09 equal to E3-07. In this case, E3-08 is disregarded.
 3. Parameters E3-04 through E3-13 are reset to their default values when the drive is initialized.
 4. Only use E3-11, E3-12, and E3-13 to fine-tune the V/f pattern in the constant output range. These parameters rarely need to be changed.

◆ E4: Motor 2 Parameters

E4 parameters contain the motor data for motor 2. These parameters are usually set automatically during the Auto-Tuning process for vector control modes (Rotational Auto-Tuning, Stationary Auto-Tuning 1 and 2). *Refer to Auto-Tuning Fault Detection on page 379* for details if Auto-Tuning cannot be performed.

- Note:** The function for switching between two motors cannot be used with a PM motor. E4-□□ parameters are hidden when a PM motor control mode is selected (A1-02 = 5, 6, or 7).

■ E4-01: Motor 2 Rated Current

Protects the motor and calculates torque limits. Set E4-01 to the full load amps (FLA) stamped on the nameplate of motor 2. If Auto-Tuning completes successfully, the value entered to T1-04 will automatically be saved to E4-01.

No.	Parameter Name	Setting Range	Default
E4-01	Motor 2 Rated Current	10 to 200% of the drive rated current.	Determined by C6-01 and o2-04

- Note:**
1. The number of decimal places in the parameter value depends on the drive model and the ND/HD selection in parameter C6-01. This value has two decimal places (0.01 A) if the drive is set for a maximum applicable motor capacity up to and including 11 kW, and one decimal place (0.1 A) if the maximum applicable motor capacity is higher than 11 kW. *Refer to Power Ratings on page 463* for details.
 2. An oPE02 error will occur if the motor rated current in E4-01 is set lower than the motor no-load current in E4-03. Set E4-03 correctly to prevent this error.

■ E4-02: Motor 2 Rated Slip

Sets the motor 2 rated slip frequency and is the basis for slip compensation value. The drive calculates this value automatically during Auto-Tuning (Rotational Auto-Tuning and Stationary Auto-Tuning 1, 2).

Refer to E2-02: Motor Rated Slip on page 227 for information on calculating the motor rated slip.

No.	Parameter Name	Setting Range	Default
E4-02	Motor 2 Rated Slip	0.00 to 20.00 Hz	Determined by C6-01 and o2-04

■ E4-03: Motor 2 Rated No-Load Current

Sets the no-load current for motor 2 in amperes when operating at the rated frequency and the no-load voltage. The drive sets E2-03 during the Auto-Tuning process (Rotational Auto-Tuning and Stationary Auto-Tuning 1, 2). The motor no-load current listed in the motor test report can also be entered to E2-03 manually. Contact the motor manufacturer for a copy of the motor test report.

5.5 E: Motor Parameters

No.	Parameter Name	Setting Range	Default
E4-03	Motor 2 Rated No-Load Current	0 to [E4-01]	Determined by C6-01 and o2-04

Note: The number of decimal places in the parameter value depends on the drive model and the ND/HD selection in parameter C6-01. This value has two decimal places (0.01 A) if the drive is set for a maximum applicable motor capacity up to and including 11 kW, and one decimal place (0.1 A) if the maximum applicable motor capacity is higher than 11 kW. [Refer to Power Ratings on page 463](#) for details.

■ E4-04: Motor 2 Motor Poles

Sets the number of poles for motor 2. If Auto-Tuning completes successfully, the value entered to T1-06 will be automatically saved to E4-04.

No.	Parameter Name	Setting Range	Default
E4-04	Motor 2 Motor Poles	2 to 48	4

■ E4-05: Motor 2 Line-to-Line Resistance

Sets the line-to-line resistance for the motor 2 stator winding. If Auto-Tuning completes successfully, this value is automatically calculated. Enter this value as line-to-line and not for each motor phase. [Refer to E2-05: Motor Line-to-Line Resistance on page 228](#) to manually enter this parameter setting.

No.	Parameter Name	Setting Range	Default
E4-05	Motor 2 Line-to-Line Resistance	0.000 to 65000 mΩ <1>	Determined by C6-01 and o2-04

<1> Units are expressed in mΩ for models 4A0930 and 4A1200.

■ E4-06: Motor 2 Leakage Inductance

Sets the voltage drop due to motor leakage inductance as a percentage of rated voltage of motor 2. This value is automatically set during Auto-Tuning (Rotational Auto-Tuning and Stationary Auto-Tuning 1, 2).

No.	Parameter Name	Setting Range	Default
E4-06	Motor 2 Leakage Inductance	0.0 to 40.0%	Determined by C6-01 and o2-04

■ E4-07: Motor 2 Motor Iron-Core Saturation Coefficient 1

Sets the motor 2 iron saturation coefficient at 50% of magnetic flux. This value is automatically set during Rotational Auto-Tuning. Adjust this parameter when operating in the constant output range.

No.	Parameter Name	Setting Range	Default
E4-07	Motor 2 Motor Iron-Core Saturation Coefficient 1	0.00 to 0.50	0.50

■ E4-08: Motor 2 Motor Iron-Core Saturation Coefficient 2

Sets the motor iron saturation coefficient at 75% of magnetic flux. This value is automatically set during Rotational Auto-Tuning. Adjust this parameter when operating in the constant output range.

No.	Parameter Name	Setting Range	Default
E4-08	Motor 2 Motor Iron-Core Saturation Coefficient 2	[E4-07] to 0.75	0.75

■ E4-09: Motor 2 Mechanical Loss

Sets the motor mechanical loss as a percentage of motor rated power (kW).

Although E4-09 rarely needs to be changed, adjustment may be necessary in the following circumstances:

- When there is a large amount of torque loss due to motor bearing friction.
- When there is a large amount of torque loss in a fan or pump application.

The setting for the mechanical loss is added to the torque.

No.	Parameter Name	Setting Range	Default
E4-09	Motor 2 Mechanical Loss	0.0 to 10.0%	0.0%

■ E4-10: Motor 2 Iron Loss

Sets the motor 2 iron loss in watts.

No.	Parameter Name	Setting Range	Default
E4-10	Motor 2 Iron Loss	0 to 65535 W	Determined by C6-01 and o2-04

■ E4-11: Motor 2 Rated Power

Sets the motor 2 rated power. If Auto-Tuning completes successfully, the value entered to T1-02 will automatically be saved to E4-11.

No.	Parameter Name	Setting Range	Default
E4-11	Motor 2 Rated Power	0.00 to 650.00 kW	Determined by o2-04

Note: The display resolution depends on the rated output power of the drive after setting the Drive Duty in parameter C6-01. Drive models 2A0004 to 4A0515 display this value in units of 0.01 kW (two decimal places). Drive models 4A0675 to 4A1200 display this value in units of 0.1 kW (one decimal place). *Refer to Nameplate on page 35* for details.

◆ E5: PM Motor Settings

Note: PM motor control modes are not available on 600 V class drives, models 5A□□□□.

These parameters set the motor data of a PM motor.

When using Yaskawa motors, set up the E5-□□ parameters by entering the motor code written on the motor nameplate.

Perform Auto-Tuning for all other PM motors. The motor data can also be entered manually, if known.

- Note:**
1. E5-□□ parameters are visible only when a PM motor control mode is selected (A1-02 = 5, 6, or 7).
 2. E5-□□ parameters are not reset when the drive is initialized using parameter A1-03.

■ E5-01: Motor Code Selection

Note: PM motor control modes are not available on 600 V class drives, models 5A□□□□.

When using Yaskawa motors, set the motor code for the PM motor being used. The drive automatically sets several parameters to appropriate values depending on the motor code.

Setting parameter E5-01 to FFFF allows the motor data to be manually set using the E5-□□ parameters.

No.	Parameter Name	Setting Range	Default
E5-01	Motor Code Selection	0000 to FFFF	Determined by A1-02, C6-01 and o2-04

- Note:**
1. E5-□□ parameters are not reset when the drive is initialized using parameter A1-03.
 2. When E5-01 is set to a value other than FFFF, the drive will not initialize using parameter A1-03
 3. Changing E5-01 to FFFF from value other than FFFF will not change the values of parameters E5-02 through E5-24.
 4. Set E5-01 to FFFF when using a motor other than a Yaskawa SMRA, SSR1, or SST4 series.
 5. Default settings are:
 OLV/PM, AOLV/PM: Yaskawa SSR1 Series (1750 r/min)
 CLV/PM: Yaskawa SSR4 Series (1750 r/min)
 6. Selection may vary depending on the motor code entered to E5-01.

Figure 5.57 explains the motor code setting.

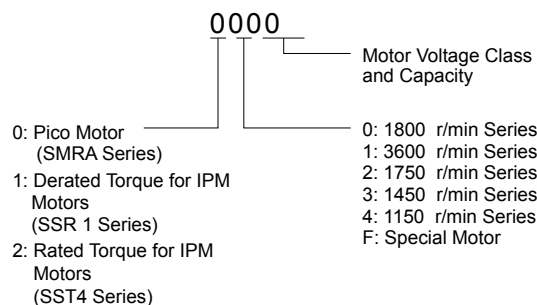

Figure 5.57 PM Motor Code

5.5 E: Motor Parameters

■ E5-02: Motor Rated Power

Note: PM motor control modes are not available on 600 V class drives, models 5A□□□□.

Sets the rated power of the motor. Determined by the value set to T2-04 during Stationary Auto-Tuning for PM motors or by entering the motor code to E5-01.

No.	Parameter Name	Setting Range	Default
E5-02	Motor Rated Power	0.10 to 650.00 kW	Determined by E5-01

■ E5-03: Motor Rated Current

Note: PM motor control modes are not available on 600 V class drives, models 5A□□□□.

Sets the motor rated current in amps. Automatically set when the value is entered to T2-06 during Auto-Tuning.

No.	Parameter Name	Setting Range	Default
E5-03	Motor Rated Current	10 to 200% of drive rated current	Determined by E5-01

Note: The number of decimal places in the parameter value depends on the drive model and the ND/HD selection in parameter C6-01. This value has two decimal places (0.01 A) if the drive is set for a maximum applicable motor capacity up to and including 11 kW, and one decimal place (0.1 A) if the maximum applicable motor capacity is higher than 11 kW. *Refer to Power Ratings on page 463* for details.

■ E5-04: Number of Motor Poles

Note: PM motor control modes are not available on 600 V class drives, models 5A□□□□.

Sets the number of motor poles. Automatically set when the value is entered to T2-08 during Auto-Tuning.

No.	Parameter Name	Setting Range	Default
E5-04	Number of Motor Poles	2 to 48	Determined by E5-01

■ E5-05: Motor Stator Resistance (r1)

Note: PM motor control modes are not available on 600 V class drives, models 5A□□□□.

Set the resistance for one motor phase. Do not enter the line-to-line resistance into E5-05 when measuring the resistance manually.

No.	Parameter Name	Setting Range	Default
E5-05	Motor Stator Resistance	0.000 to 65.000 Ω	Determined by E5-01

■ E5-06: Motor d-Axis Inductance (Ld)

Note: PM motor control modes are not available on 600 V class drives, models 5A□□□□.

Sets the d-Axis inductance in 0.01 mH units. This parameter is set during the Auto-Tuning process.

No.	Parameter Name	Setting Range	Default
E5-06	Motor d-Axis Inductance	0.00 to 300.00 mH	Determined by E5-01

■ E5-07: Motor q-Axis Inductance (Lq)

Note: PM motor control modes are not available on 600 V class drives, models 5A□□□□.

Sets the q-Axis inductance in 0.01 mH units. This parameter is set during the Auto-Tuning process.

No.	Parameter Name	Setting Range	Default
E5-07	Motor q-Axis Inductance	0.00 to 600.00 mH	Determined by E5-01

■ E5-09: Motor Induction Voltage Constant 1 (Ke)

Note: PM motor control modes are not available on 600 V class drives, models 5A□□□□.

Sets the induced peak voltage per phase in units of 0.1 mV/(rad/s) [electrical angle]. Set this parameter when using an IPM motor with derated torque (SSR1 series or equivalent) or an IPM motor with constant torque (SST4 series or equivalent).

Set the voltage constant with E5-09 or E5-24 when E5-01 is set to FFFF. This parameter is set during Auto-Tuning for PM motors.

No.	Parameter Name	Setting Range	Default
E5-09	Motor Induction Voltage Constant 1	0.0 to 2000.0 mV/(rad/s)	Determined by E5-01

Note: Set E5-24 to 0 when setting E5-09. However, setting both E5-09 and E5-24 to 0 will trigger an alarm. An alarm will also be triggered if neither E5-09 nor E5-24 are set to 0. When E5-01 is set to FFFF, then E5-09 = 0.0.

■ E5-11: Encoder Z Pulse Offset ($\Delta\theta$)

Note: PM motor control modes are not available on 600 V class drives, models 5A□□□□.

Sets the offset between the rotor magnetic axis and the Z Pulse of the connected encoder. This parameter is set during Auto-Tuning for PM motors and during Z Pulse Tuning.

No.	Parameter Name	Setting Range	Default
E5-11	Encoder Z Pulse Offset	-180.0 to 180.0 deg	0.0 deg

■ E5-24: Motor Induction Voltage Constant 2 (K_e)

Note: PM motor control modes are not available on 600 V class drives, models 5A□□□□.

Set the induced phase-to-phase rms voltage in units of 0.1 mV/(r/min) [mechanical angle]. Set this parameter when using an SPM Motor (SMRA Series or equivalent).

When E5-01 is set to FFFF, use either E5-09 or E5-24 for setting the voltage constant. This parameter is set during Parameter Auto-Tuning for PM motors.

No.	Parameter Name	Setting Range	Default
E5-24	Motor Induction Voltage Constant 2	0.0 to 6500.0 mV/(r/min)	Determined by E5-01

Note: Set E5-24 to 0.0 when setting E5-09. However, setting both E5-09 and E5-24 to 0.0 will trigger an alarm. An alarm will also be triggered if neither E5-09 nor E5-24 are set to 0.0. When E5-01 is set to FFFF, then E5-09 should be set to 0.0.

■ E5-25: Polarity Switch for Initial Polarity Estimation

Note: PM motor control modes are not available on 600 V class drives, models 5A□□□□.

Switches polarity for initial polarity estimation.

- Note:**
1. This parameter setting rarely needs to be changed.
 2. This parameter is only available in models 4A0930 and 4A1200.

No.	Parameter Name	Setting Range	Default
E5-25	Polarity Switch for Initial Polarity Estimation	0, 1	0

5.6 F: Option Settings

◆ F1: PG Speed Control Card Settings

Yaskawa offers a PG-X3 and PG-B3 motor encoder PG option card. Use the CN5-C port when using only one PG option card and use the CN5-C and CN5-B ports when using two PG option cards. When programming one of the multi-function input terminals to act as a switch between two motors (H1-□□= 16), use the card connected to port CN5-C for motor 1 and use the card connected to CN5-B for motor 2.

[Table 5.35](#) lists the parameters that must be set for each option card port.

Table 5.35 Option Card Ports and Corresponding Parameters

Port	Parameters
CN5-C and CN5-B (common)	F1-02 to F1-04, F1-08 to F1-11, F1-14
CN5-C only	F1-01, F1-05, F1-06, F1-12, F1-13, F1-18 to F1-21
CN5-B only	F1-31 to F1-37

■ F1-01, F1-31: PG 1 and PG 2 Pulses Per Revolution

Sets the number encoder number of pulses per revolution.

No.	Parameter Name	Option Port	Setting Range	Default
F1-01	PG 1 Pulses Per Revolution	CN5-C	0 to 60000 ppr <1>	1024 ppr
F1-31	PG 2 Pulses Per Revolution	CN5-B	0 to 60000 ppr	1024 ppr

<1> Setting range is 0 to 15000 in PM motor control modes

■ F1-02, F1-14: PG Open (PGo) Circuit Operation Selection, Detection Time

A PGo fault is triggered if the drive receives no pulse signal for longer than the time set in F1-14. Set the stopping method for a PGo fault in parameter F1-02.

No.	Parameter Name	Option Port	Setting Range	Default
F1-02	Operation Selection at PG Open Circuit (PGo)	CN5-B, CN5-C	0 to 3	1
F1-14	PG Open-Circuit Detection Time	CN5-B, CN5-C	0.0 to 10.0 s	2.0 s

Parameter F1-02 Settings:

Setting 0: Ramp to stop (uses the deceleration time set to C1-02)

Setting 1: Coast to stop

Setting 2: Fast Stop (uses the Fast Stop time set to C1-09)

Setting 3: Alarm only

Note: Due to potential damage to motor and machinery, refrain from using the “Alarm only” or “No alarm display” settings except under special circumstances.

Setting 4: No alarm display

Note: Due to potential damage to motor and machinery, refrain from using the “Alarm only” or “No alarm display” settings except under special circumstances.

■ F1-03, F1-08, F1-09: Overspeed (oS) Operation Selection, Detection Level, Delay Time

An oS fault is triggered when the speed feedback exceeds the value set in F1-08 for longer than the time set in F1-09. Set the stopping method for an oS fault in parameter F1-03.

No.	Parameter Name	Option Port	Setting Range	Default
F1-03	Operation Selection at Overspeed (oS)	CN5-B, CN5-C	0 to 3	1
F1-08	Overspeed Detection Level	CN5-B, CN5-C	0 to 120%	115%
F1-09	Overspeed Detection Delay Time	CN5-B, CN5-C	0.0 to 2.0 s	Determined by A1-02

Parameter F1-03 Settings:

Setting 0: Ramp to stop (uses the deceleration time set to C1-02)

Setting 1: Coast to stop**Setting 2: Fast Stop (uses the Fast Stop time set to C1-09)****Setting 3: Alarm only**

Note: Due to potential damage to motor and machinery, refrain from using the “Alarm only” setting except under special circumstances.

■ F1-04, F1-10, F1-11: Operation at Speed Deviation (dEv), Detection Level, Delay Time

A speed deviation error (dEv) is triggered when the difference between the frequency reference and the speed feedback exceeds the value set in F1-10 for longer than the time set in F1-1. The stopping method when a speed deviation fault occurs can be selected in parameter F1-04.

No.	Parameter Name	Option Port	Setting Range	Default
F1-04	Operation Selection at Deviation (dEv)	CN5-B, CN5-C	0 to 3	3
F1-10	Excessive Speed Deviation Detection Level	CN5-B, CN5-C	0 to 50%	10%
F1-11	Excessive Speed Deviation Detection Delay Time	CN5-B, CN5-C	0.0 to 10.0 s	0.5 s

Settings for Parameter F1-04:**Setting 0: Ramp to stop (uses the deceleration time set to C1-02)****Setting 1: Coast to stop****Setting 2: Fast Stop (uses the Fast Stop time set to C1-09)****Setting 3: Alarm only (drive continues operating while “dEv” flashes on the screen)****■ F1-05, F1-32: PG 1, PG 2 Rotation Selection**

Determines the direction indicated by the pulses from the PG feedback encoder for motor 1 and motor 2.

See PG option card instruction manual for details on setting the direction for the PG encoder and the motor.

No.	Parameter Name	Option Port	Setting Range	Default
F1-05	PG 1 Rotation Selection	CN5-C	0, 1	Determined by A1-02 <1>
F1-32	PG 2 Rotation Selection	CN5-B	0, 1	0

<1> Default is 0 when A1-02 = 1 or 3. Default is 1 when A1-02 = 7.

Setting 0: A pulse leads with Forward run command**Setting 1: B pulse leads with Forward run command****■ F1-06, F1-35: PG 1, PG 2 Division Rate for PG Pulse Monitor**

Sets the ratio between the pulse input and the pulse output of a PG option card as a three-digit number, where the first digit (n) sets the numerator and the second and third digit (m) set the denominator as shown below:

$$f_{\text{Pulse Input}} = f_{\text{Pulse Output}} \cdot \frac{(1 + n)}{m}$$

Example: Set F1-06 to 032 for a ratio of 1/32 between the PG card pulse input and output.

No.	Parameter Name	Option Port	Setting Range	Default
F1-06	PG 1 Division Rate for PG Pulse Monitor	CN5-C	1 to 132 (1 to $\frac{1}{32}$)	1
F1-35	PG 2 Division Rate for PG Pulse Monitor	CN5-B	1 to 132 (1 to $\frac{1}{32}$)	1

■ F1-12, F1-13, F1-33, F1-34: PG 1, PG 2 Gear Teeth 1, 2 (V/f w/PG only)

Sets the gear ratio between the motor shaft and the PG encoder. F1-12 and F1-33 set the number of gear teeth on the motor side, while F1-13 and F-34 set the number of gear teeth on the load side. The drive uses the formula below to calculate the motor speed:

$$r/\text{min} = \frac{\text{Input pulses from PG} \cdot 60}{\text{Pulses per Rev (F1-01/31)}} \cdot \frac{\text{Load-side PG gear teeth (F1-12/33)}}{\text{Motor-side PG gear teeth (F1-13/34)}}$$

5.6 F: Option Settings

No.	Parameter Name	Option Port	Setting Range	Default
F1-12	PG 1 Gear Teeth 1	CN5-C	0 to 1000	0
F1-13	PG 1 Gear Teeth 2	CN5-C	0 to 1000	0
F1-33	PG 2 Gear Teeth 1	CN5-B	0 to 1000	0
F1-34	PG 2 Gear Teeth 2	CN5-B	0 to 1000	0

Note: A gear ratio of 1 will be used if any of these parameters are set to 0.

■ F1-18: dv3 Detection Selection (CLV/PM)

Note: PM motor control modes are not available on 600 V class drives, models 5A□□□□.

Sets the number of times the drive will detect a dv3 situation before triggering a dv3 fault. The drive detects a dv3 condition when the torque reference and speed reference are in opposite directions while the difference between the actual motor speed and the speed reference is greater than 30%. Setting F1-18 to 0 disables dv3 detection.

No.	Parameter Name	Option Port	Setting Range	Default
F1-18	dv3 Detection Selection	CN5-B, CN5-C	0 to 10	10

Note: A common cause for a dv3 fault is the incorrect setting of E5-11. Make sure to enter the correct Z Pulse offset to E5-11.

■ F1-19: dv4 Detection Selection (CLV/PM)

Note: PM motor control modes are not available on 600 V class drives, models 5A□□□□.

Sets the number of pulses necessary to trigger a dv4 fault when there is a motor speed deviation opposite to the frequency reference. Setting F1-19 to 0 disables dv4 detection.

No.	Parameter Name	Option Port	Setting Range	Default
F1-19	dv4 Detection Selection	CN5-B, CN5-C	0 to 5000	128

- Note:**
1. A common cause for a dv4 fault is the incorrect setting of E5-11. Make sure to enter the correct Z-pulse offset to E5-11.
 2. Set F1-19 to 0 for applications where the direction of the load is the opposite of the speed reference.

■ F1-20, F1-36: PG Option Card Disconnect Detection

Sets whether the drive detects a fault when a PG-X3 card is disconnected.

No.	Parameter Name	Option Port	Setting Range	Default
F1-20	PG Option Card Disconnection Detection 1	CN5-C	0, 1	1
F1-36	PG Option Card Disconnection Detection 2	CN5-B	0, 1	1

Setting 0: Disabled

Setting 1: Enabled

■ F1-21, F1-37: PG 1, PG 2 Signal Selection (V/f w/PG only)

Determines whether the signal to the PG option card is single-channel or two-channel.

No.	Parameter Name	Option Port	Setting Range	Default
F1-21	PG 1 Signal Selection	CN5-C	0, 1	0
F1-37	PG 2 Signal Selection	CN5-B	0, 1	0

Setting 0: Single-channel (A channel only)

Setting 1: Two-channel (channels A and B)

■ F1-30: PG Option Card Port for Motor 2 Selection

Specifies the drive port for the PG option card used for motor 2. Set this parameter when switching between motor 1 and motor 2, where both motors supply a speed feedback signal to the drive. Set F1-30 to 0 when using the same PG card for feedback signals from both motors. Set F1-30 to 1 when each motor has its own PG card connected to the drive.

Note: The motor 2 selection function cannot be used with PM motors.

No.	Parameter Name	Setting Range	Default
F1-30	PG Option Card Port for Motor 2 Selection	0, 1	1

Setting 0: CN5-C

Setting 1: CN5-B

◆ F2: Analog Input Card Settings

These parameters set the drive for operation with the analog input option card AI-A3. This section describes parameters that govern operation with an input option card. Refer to the option card instruction manual for specific details on installation, wiring, input signal level selection, and parameter setup.

■ F2-01: Analog Input Option Card Operation Selection

Determines how the input terminals on the AI-A3 option card are used.

No.	Parameter Name	Setting Range	Default
F2-01	Analog Input Option Card Operation Selection	0, 1	0

Setting 0: Separate functions for each terminal (V1, V2, V3 replace terminals A1, A2, A3)

Use the H3-□□ parameters described in [H3-03, H3-04: Terminal A1 Gain and Bias Settings](#) on page 269 to set the functions and gain and bias levels for an analog reference supplied by AI-A3.

Note: Setting option card terminals for separate input functions (F2-01 = 0) while b1-01 = 3 will cause an oPE05 error.

Setting 1: Combine input terminal values to create frequency reference

This setting adds all three input signals on the AI-A3 option card to create the frequency reference. Set b1-01 to 3 when the option card is the source of the frequency reference for the drive. Set the gain and bias settings for the frequency reference supplied from AI-A3 with F2-02 and F2-03.

■ F2-02, F2-03: Analog Input Option Card Gain, Bias

Parameter F2-02 sets the gain and parameter F2-03 sets the bias for the AI-A3 input signal when the card is used in the combined input signals mode (F2-01 = 1). Both gain and bias are set as a percentage of the maximum output frequency.

No.	Parameter Name	Setting Range	Default
F2-02	Analog Input Option Card Gain	-999.9 to 999.9%	100.0%
F2-03	Analog Input Option Card Bias	-999.9 to 999.9%	0.0%

Note: Enabled only when F2-01 = 1.

◆ F3: Digital Input Card Settings

These parameters set the drive for operation with the option card DI-A3. Refer to the instruction manual packaged with the option card for specific details on installation, wiring, input signal level selection, and parameter setup.

■ F3-01: Digital Input Option Card Input Selection

Determines the type of input for digital option card DI-A3 when o1-03 is set to 0 or 1.

No.	Parameter Name	Setting Range	Default
F3-01	Digital Input Option Card Input Selection	0 to 7	0

Note: BCD input when o1-03 = 2 or 3. Units are determined by o1-03.

Setting 0: BCD, 1% units

Setting 1: BCD, 0.1% units

5.6 F: Option Settings

Setting 2: BCD, 0.01% units

Setting 3: BCD, 1 Hz units

Setting 4: BCD, 0.1 Hz units

Setting 5: BCD, 0.01 Hz units

Setting 6: BCD, special setting (5 digit input), 0.02 Hz units

Setting 7: Binary

The unit and the setting range are determined by F3-03.

F3-03 = 0: 255/100% (-255 to +255)

F3-03 = 1: 4095/100% (-4095 to +4095)

F3-03 = 2: 30000/100% (-33000 to +33000)

Note: BCD input when o1-03 = 2 or 3. Units are determined by o1-03.

■ F3-03: Digital Input Option DI-A3 Data Length Selection

Determines the number of bits for the option card input that sets the frequency reference.

No.	Parameter Name	Setting Range	Default
F3-03	Digital Input Option DI-A3 Data Length Selection	0 to 2	2

Setting 0: 8 bit

Setting 1: 12 bit

Setting 2: 16 bit

◆ F4: Analog Monitor Card Settings

These parameters set the drive for operation with the analog output option card AO-A3. Refer to the instruction manual packaged with the option card for specific details on installation, wiring, input signal level selection, and parameter setup.

■ F4-01, F4-03: Terminal V1, V2 Monitor Selection

Selects the data to output from analog terminal V1. Enter the final three digits of U□-□□ to determine which monitor data is output from the option card. Some monitors are only available in certain control modes.

No.	Parameter Name	Setting Range	Default
F4-01	Terminal V1 Monitor Selection	000 to 999	102
F4-03	Terminal V2 Monitor Selection	000 to 999	103

■ F4-02, F4-04, F4-05, F4-06: Terminal V1, V2 Monitor Gain and Bias

Parameters F4-02 and F4-04 determine the gain, while parameters F4-05 and F4-06 set the bias. These parameters are set as a percentage of the output signal from V1 and V2 where 100% equals 10 V output. The terminal output voltage is limited to 10 V.

No.	Parameter Name	Setting Range	Default
F4-02	Terminal V1 Monitor Gain	-999.9 to 999.9%	100.0%
F4-04	Terminal V2 Monitor Gain	-999.9 to 999.9%	50.0%
F4-05	Terminal V1 Monitor Bias	-999.9 to 999.9%	0.0%
F4-06	Terminal V2 Monitor Bias	-999.9 to 999.9%	0.0%

Using Gain and Bias to Adjust Output Signal Level

The output signal is adjustable while the drive is stopped.

Terminal V1

1. View the value set to F4-02 (Terminal V1 Monitor Gain) on the digital operator. A voltage equal to 100% of the parameter being set in F4-01 will be output from terminal V1.

2. Adjust F4-02 viewing the monitor connected to the terminal V1.
3. View the value set to F4-05 on the digital operator, terminal V1 will output a voltage equal to 0% of the parameter being set in F4-01.
4. Adjust F4-05 viewing the output signal on the terminal V1.

Terminal V2

1. View the value set to F4-02 (Terminal V2 Monitor Gain) on the digital operator. A voltage equal to 100% of the parameter being viewed in F4-03 will be output from terminal V2.
2. Adjust F4-04 viewing the monitor connected to the terminal V2.
3. View the value set to F4-06 on the digital operator, terminal V2 will output a voltage equal to 0% of the parameter being set in F4-03.
4. Adjust F4-06 viewing the output signal on the terminal V2.

■ F4-07, F4-08: Terminal V1, V2 Signal Level

Sets the output signal level for terminals V1 and V2.

No.	Parameter Name	Setting Range	Default
F4-07	Terminal V1 Signal Level	0, 1	0
F4-08	Terminal V2 Signal Level	0, 1	0

Setting 0: 0 to 10 V

Setting 1: -10 to 10 V

◆ F5: Digital Output Card Settings

These parameters set the drive for operation with the digital output option card DO-A3. Refer to the instruction manual packaged with the option card for specific details on installation, wiring, input signal level selection, and parameter setup.

■ F5-01 through F5-08: Digital Output Option Card Terminal Function Selection

When F5-09 = 2, the parameters listed in the table below assign functions to the output terminals on the option card.

No.	Name	Setting Range	Default
F5-01	Terminal P1-PC Output Selection	0 to 192	2: Speed agree
F5-02	Terminal P2-PC Output Selection	0 to 192	4: Frequency detection 1
F5-03	Terminal P3-PC Output Selection	0 to 192	6: Drive ready
F5-04	Terminal P4-PC Output Selection	0 to 192	37: During frequency output
F5-05	Terminal P5-PC Output Selection	0 to 192	F: Not used
F5-06	Terminal P6-PC Output Selection	0 to 192	F: Not used
F5-07	Terminal M1-M2 Output Selection	0 to 192	0: During run
F5-08	Terminal M3-M4 Output Selection	0 to 192	1: Zero speed

■ F5-09: DO-A3 Output Mode Selection

Determines how the DO-A3 option card works with the drive.

No.	Parameter Name	Setting Range	Default
F5-09	DO-A3 Output Mode Selection	0 to 2	0

Note: Refer to TOBP C730600 41 Yaskawa AC Drive-Option DO-A3 Installation Manual for more details on F5-09 settings.

Setting 0: Separate output functions for each of 8 terminals

Setting 1: Binary output

Setting 2: Output functions assigned by F5-01 through F5-08

5.6 F: Option Settings

◆ F6: Communication Option Card

These parameters configure communication option cards and communication fault detection methods.

Some parameters apply to all communication option cards and some parameters apply to certain network options only. The option cards are applicable to the parameter rows marked with an “O”.

Parameter	Communication Protocol				
	CC-Link	MECHATROLINK-II	PROFIBUS-DP	CANopen	DeviceNet
F6-01 to F6-03, F6-06 to F6-08	O	O	O	O	O
F6-04, F6-10, F6-11, F6-14	O	–	–	–	–
F6-20 to F6-26	–	O	–	–	–
F6-30 to F6-32	–	–	O	–	–
F6-35 to F6-36	–	–	–	O	–
F6-50 to F6-63	–	–	–	–	O

■ F6-01: Communications Error Operation Selection

Determines drive operation when a communication error occurs.

No.	Parameter Name	Setting Range	Default
F6-01	Communications Error Operation Selection	0 to 3	1

Setting 0: Ramp to stop (uses the deceleration time set to C1-02)

Setting 1: Coast to stop

Setting 2: Fast Stop (uses the Fast Stop time set to C1-09)

Setting 3: Alarm only (continue operation)

■ F6-02: External Fault from Comm. Option Detection Selection

Determines the detection method of an external fault initiated by a communication option (EF0).

No.	Parameter Name	Setting Range	Default
F6-02	External Fault from Comm. Option Detection Selection	0, 1	0

Setting 0: Always detected

Setting 1: Detection during Run only

■ F6-03: External Fault from Comm. Option Operation Selection

Determines drive operation when an external fault is initiated by a communication option (EF0).

No.	Parameter Name	Setting Range	Default
F6-03	External Fault from Comm. Option Operation Selection	0 to 3	1

Setting 0: Ramp to stop

Setting 1: Coast to stop

Setting 2: Fast Stop

Setting 3: Alarm only (continue operation)

■ F6-06: Torque Reference/Torque Limit Selection from Comm. Option

Selects whether torque reference and torque limit values are assigned to the drive from the network.

No.	Parameter Name	Setting Range	Default
F6-06	Torque Reference/Torque Limit Selection from Comm. Option	0, 1	0

Setting 0: Enabled

Setting 1: Disabled

■ F6-07: NetRef/ComRef Function Selection

Selects the treatment of multi-step speed inputs when the NetRef command is set.

No.	Parameter Name	Setting Range	Default
F6-07	NetRef/ComRef Function Selection	0, 1	0

Setting 0: Multi-step speed operation disabled

Multi-step speed input frequency references are disabled when the NetRef command is selected.

Setting 1: Multi-step speed operation enabled

Multi-step speed inputs are still active and can override the frequency reference from the communications option even when the NetRef command is selected.

■ F6-08: Reset Communication Parameters

Determines whether F6-□□ communication-related parameters are reset after initialization.

No.	Parameter Name	Setting Range	Default
F6-08	Reset Communication Parameters	0, 1	0

Setting 0: Do not reset F6-□□ parameters after initialization using A1-03

Setting 1: Reset F6-□□ parameters after initialization using A1-03

Note: F6-08 is not reset when the drive is initialized.

◆ CC-Link Parameters

Parameters F6-04, F6-10, F6-11, and F6-14 set the drive to operate on a CC-Link network.

■ F6-04: bUS Error Detection Time

Sets the delay time for bUS error detection.

No.	Parameter Name	Setting Range	Default
F6-04	bUS Error Detection Time	0.0 to 5.0 s	2.0 s

■ F6-10: CC-Link Node Address

Sets the node address of a CC-Link option board.

No.	Parameter Name	Setting Range	Default
F6-10	CC-Link Node Address	0 to 64	0

■ F6-11: CC-Link Communication Speed

Sets the communication speed for a CC-Link option card.

No.	Parameter Name	Setting Range	Default
F6-11	CC-Link Communication Speed	0 to 4	0

Settings:

F6-11	Communication Speed	F6-11	Communication Speed
0	156 kbps	3	5 Mbps
1	625 kbps	4	10 Mbps
2	2.5 Mbps	–	–

■ F6-14: CC-Link bUS Error Auto Reset

Selects whether a bUS error can be automatically reset if automatic fault retry is enabled.

5.6 F: Option Settings

No.	Parameter Name	Setting Range	Default
F6-14	CC-Link bUS Error Auto Reset	0, 1	0

Setting 0: Disabled, auto reset not possible

Setting 1: Enabled, auto reset possible

◆ PROFIBUS-DP Parameters

Parameters F6-30 through F6-32 set the drive to run on a PROFIBUS-DP network.

■ F6-30: PROFIBUS-DP Node Address

Sets the node address of a PROFIBUS-DP option card.

No.	Parameter Name	Setting Range	Default
F6-30	PROFIBUS-DP Node Address	0 to 125	0

■ F6-31: PROFIBUS-DP Clear Mode Selection

Determines the operation when a Clear Mode command is received.

No.	Parameter Name	Setting Range	Default
F6-31	PROFIBUS-DP Clear Mode Selection	0, 1	0

Setting 0: Reset

Resets the drive operation (frequency reference, inputs, outputs etc.).

Setting 1: Maintain the previous state

Returns the drive status to the state prior to receiving the command.

■ F6-32: PROFIBUS-DP Data Format Selection

Selects the data format used for PROFIBUS-DP communication.

No.	Parameter Name	Setting Range	Default
F6-32	PROFIBUS-DP Data Format Selection	0, 1	0

Setting 0: PPO-type data format

Setting 1: Conventional data format

◆ CANopen Parameters

Parameters F6-35 and F6-36 set the drive to operate on a CANopen network.

■ F6-35: CANopen Node ID Selection

Selects the node ID of a CANopen option board.

No.	Parameter Name	Setting Range	Default
F6-35	CANopen Node ID Selection	0 to 126	0

■ F6-36: CANopen Communication Speed

Sets the communication speed for a CANopen option card.

No.	Parameter Name	Setting Range	Default
F6-36	CANopen Communication Speed	0 to 8	6

Settings:

F6-36	Communication Speed	F6-36	Communication Speed
0	Auto detection	5	250 kbps
1	10 kbps	6	500 kbps
2	20 kbps	7	800 kbps
3	50 kbps	8	1 Mbps
4	125 kbps	–	–

◆ DeviceNet Parameters

Parameters F6-50 through F6-63 set the drive to operate on a DeviceNet network.

■ F6-50: DeviceNet MAC Address

Sets the MAC address for a DeviceNet option card.

No.	Parameter Name	Setting Range	Default
F6-50	DeviceNet MAC Address	0 to 64	64

■ F6-51: DeviceNet Communication Speed

Sets the communication speed for a DeviceNet option card.

To assign the baud rate for the drive from the upper controller, set F6-51 = 3.

To make the drive detect the network speed, set F6-51 = 4. The drive will automatically adjust itself after detecting the network speed.

No.	Parameter Name	Setting Range	Default
F6-51	DeviceNet Communication Speed	0 to 4	4

Settings:

F6-51	Communication Speed	F6-51	Communication Speed
0	125 kbps	3	Adjustable from Network
1	250 kbps	4	Auto detection
2	500 kbps	–	–

■ F6-52: DeviceNet PCA Setting

Defines the format for data the drive receives from the DeviceNet master.

No.	Parameter Name	Setting Range	Default
F6-52	DeviceNet PCA Setting	0 to 255	21

■ F6-53: DeviceNet PPA Setting

Defines the format for data sent from the drive to the DeviceNet master.

No.	Parameter Name	Setting Range	Default
F6-53	DeviceNet PPA Setting	0 to 255	71

■ F6-54: DeviceNet Idle Mode Fault Detection

Determines whether the drive triggers an EF0 fault when no data is received from the master (e.g., when the master is idling).

No.	Parameter Name	Setting Range	Default
F6-54	DeviceNet Idle Mode Fault Detection	0, 1	0

Setting 0: Enabled

Setting 1: Disabled, no fault detection

■ F6-55: DeviceNet Baud Rate Monitor

Displays the baud rate currently being used for network communications. F6-55 is used only as a monitor.

5.6 F: Option Settings

No.	Parameter Name	Setting Range	Default
F6-55	DeviceNet Baud Rate Monitor	0 to 2 (read only)	0

Settings:

F6-55	Communication Speed	F6-55	Communication Speed
0	125 kbps	2	500 kbps
1	250 kbps	–	–

■ F6-56 to F6-61: DeviceNet Scaling Factors

These parameters define scaling factors for drive monitors in the DeviceNet Class ID 2AH - AC/DC Drive Object.

No.	Parameter Name	Setting Range	Default
F6-56	DeviceNet Speed Scaling	-15 to 15	0
F6-57	DeviceNet Current Scaling	-15 to 15	0
F6-58	DeviceNet Torque Scaling	-15 to 15	0
F6-59	DeviceNet Power Scaling	-15 to 15	0
F6-60	DeviceNet Voltage Scaling	-15 to 15	0
F6-61	DeviceNet Time Scaling	-15 to 15	0

Setting

The monitor value in the AC/DC Drive Object 2AH is calculated by:

$$\text{AC/DC Drive Object 2AH Monitor} = \text{Drive Value} \times 2^{\text{Scaling}}$$

Example:

If the drive output frequency monitor (U1-02) is 5.00 and the scaling is set to F6-56 = 6, then the value in the AC/DC Drive Object 2AH, Instance 1, Attribute 7 would be $500 \times 2^6 = 32000$.

■ F6-62: DeviceNet Heartbeat Interval

Sets the heartbeat interval for DeviceNet communications. A setting of 0 disables the heartbeat function.

No.	Parameter Name	Setting Range	Default
F6-62	DeviceNet Heartbeat Interval	0 to 10	0

■ F6-63: DeviceNet Network MAC ID

Displays the MAC ID assigned to the drive. F6-63 is used only as a monitor.

No.	Parameter Name	Setting Range	Default
F6-63	DeviceNet Network MAC ID	0 to 63 (read only)	0

■ F6-64 to F6-71: Dynamic Assembly Parameters (Reserved)

5.7 H: Terminal Functions

H parameters assign functions to the external terminals.

◆ H1: Multi-Function Digital Inputs

■ H1-01 to H1-08: Functions for Terminals S1 to S8

These parameters assign functions to the multi-function digital inputs. The various functions and settings are listed in [Table 5.36](#).

No.	Parameter Name	Setting Range	Default
H1-01	Multi-Function Digital Input Terminal S1 Function Selection	1 to 9F	40 (F) <1> : Forward Run Command (2-Wire sequence)
H1-02	Multi-Function Digital Input Terminal S2 Function Selection	1 to 9F	41 (F) <1> : Reverse Run Command (2-Wire sequence)
H1-03	Multi-Function Digital Input Terminal S3 Function Selection	0 to 9F	24: External Fault
H1-04	Multi-Function Digital Input Terminal S4 Function Selection	0 to 9F	14: Fault Reset
H1-05	Multi-Function Digital Input Terminal S5 Function Selection	0 to 9F	3 (0) <1> : Multi-Step Speed Reference 1
H1-06	Multi-Function Digital Input Terminal S6 Function Selection	0 to 9F	4 (3) <1> : Multi-Step Speed Reference 2
H1-07	Multi-Function Digital Input Terminal S7 Function Selection	0 to 9F	6 (4) <1> : Jog Reference Selection
H1-08	Multi-Function Digital Input Terminal S8 Function Selection	0 to 9F	8: External Baseblock Command

<1> Number appearing in parenthesis is the default value after performing a 3-Wire initialization (A1-03 = 3330).

Table 5.36 Multi-Function Digital Input Terminal Settings

Setting	Function	Page	Setting	Function	Page
0	3-Wire Sequence	248	20 to 2F	External Fault	253
1	LOCAL/REMOTE Selection	248	30	PID Integral Reset	254
2	External Reference 1/2 Selection	249	31	PID Integral Hold	254
3	Multi-Step Speed Reference 1	249	32	Multi-Step Speed Reference 4	254
4	Multi-Step Speed Reference 2		34	PID Soft Starter Cancel	254
5	Multi-Step Speed Reference 3		35	PID Input Level Selection	254
6	Jog reference Selection	249	40	Forward Run Command (2-Wire sequence)	254
7	Accel/Decel Time Selection 1	249	41	Reverse Run Command (2-Wire sequence)	
8	Baseblock Command (N.O.)	249	42	Run Command (2-Wire sequence 2)	255
9	Baseblock Command (N.C.)		43	FWD/REV Command (2-Wire sequence 2)	
A	Accel/Decel Ramp Hold	249	44	Offset Frequency 1	255
B	Drive Overheat Alarm (oH2)	250	45	Offset Frequency 2	
C	Analog Terminal Input Selection	250	46	Offset Frequency 3	
D	PG Encoder Disable	250	47	Node Setup	255
E	ASR integral reset	250	60	DC Injection Braking Command	255
F	Through Mode	250	61	External Speed Search Command 1	255
10	Up Command	250	62	External Speed Search Command 2	255
11	Down Command		63	Field Weakening	255
12	Forward Jog	251	65	KEB Ride-Thru 1 (N.C.)	255
13	Reverse Jog		66	KEB Ride-Thru 1 (N.O.)	
14	Fault Reset	251	67	Communications Test Mode	256
15	Fast Stop (N.O.)	251	68	High Slip Braking (HSB)	256
16	Motor 2 Selection	252	6A	Drive Enabled	256
17	Fast Stop (N.C.)	251	71	Speed/Torque Control Switch	256
18	Timer Function Input	252	72	Zero Servo	256
19	PID Disable	253	75	Up 2 Command	256
1A	Accel/Decel Time Selection 2	253	76	Down 2 Command	
1B	Program Lockout	253	77	ASR Gain Switch	257
1E	Reference Sample Hold	253	78	External Torque Reference Polarity Inversion	257

5.7 H: Terminal Functions

Setting	Function	Page
7A	KEB Ride-Thru 2 (N.C.)	257
7B	KEB Ride-Thru 2 (N.O.)	
7C	Short Circuit Braking (N.O.)	257
7D	Short Circuit Braking (N.C.)	

Setting	Function	Page
7E	Forward/Reverse Detection (V/f control with simple PG)	258
90 to 97	DriveWorksEZ Digital Input 1 to 8	258
9F	DriveWorksEZ Disabled	258

Setting 0: 3-Wire Sequence

The digital input programmed for 3-Wire control becomes the forward/reverse directional input, S1 becomes the Run command input, and S2 becomes the Stop command input.

The drive starts the motor when the input S1 set for the Run command closes for longer than 2 ms. The drive stops the operation when the Stop input S2 releases for 2 ms. When the digital input programmed for a forward/reverse operation is open, the drive is set for forward operation. When the digital input is closed, the drive is set for reverse operation.

Note: Input the Run and Stop commands via S1 and S2 when selecting a 3-Wire sequence.

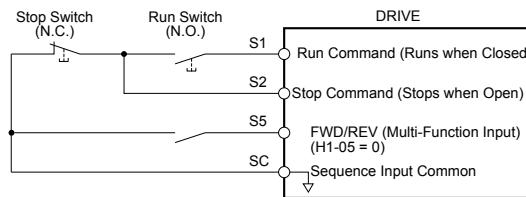

Figure 5.58 3-Wire Sequence Wiring Diagram

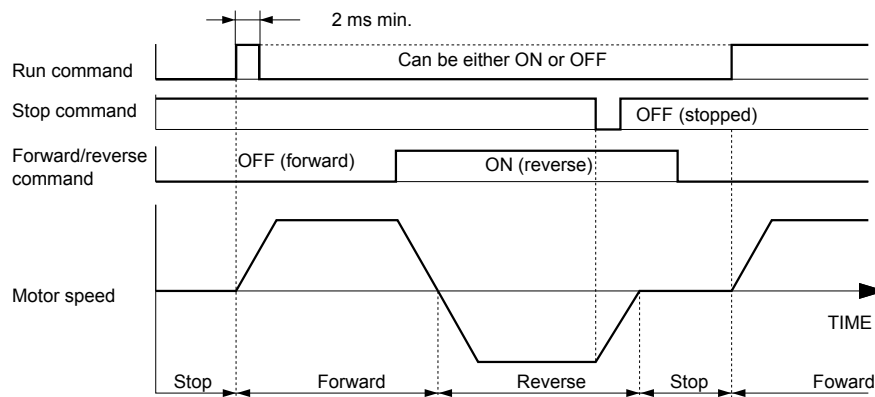

Figure 5.59 3-Wire Sequence

- Note:**
1. The Run command must be closed for more than 2 ms.
 2. If the Run command is active at power up and b1-17 = 0 (Run command at power up not accepted), the Run LED will flash to indicate that protective functions are operating. If required by the application, set b1-17 to 1 to automatically issue the Run command upon drive power up.

WARNING! Sudden Movement Hazard. Ensure start/stop and safety circuits are wired properly and in the correct state before applying power to the drive. Failure to comply could result in death or serious injury from moving equipment.

WARNING! Sudden Movement Hazard. The drive may start unexpectedly in reverse direction after power up if it is wired for 3-Wire sequence but set up for 2-Wire sequence (default). Make sure b1-17 is set to "0" (drive does not accept a Run command active at power up). When initializing the drive use 3-Wire initialization. Failure to comply could result in death or serious injury from moving equipment.

Setting 1: LOCAL/REMOTE Selection

This setting allows the input terminal to determine if the drive will run in LOCAL mode or REMOTE mode.

Status	Description
Closed	LOCAL: Frequency reference and Run command are input from the digital operator.
Open	REMOTE: Frequency reference and Run command are input from the selected external reference. If a digital input set to H1-□□ = 2 is active, they will be read from external reference source 2 (b1-15 and b1-16). In all other cases they will be read from external reference source 1 (b1-01 and b1-02).

- Note:**
1. The LO/RE key on the digital operator is disabled when one of the multi-function input terminals is set to for LOCAL/REMOTE.
 2. When the drive is set to LOCAL, the LO/RE LED will light.

- The default setting of the drive does not allow switching between LOCAL and REMOTE during run. To allow the drive to switch between LOCAL and REMOTE during run, [Refer to b1-07: LOCAL/REMOTE Run Selection on page 169.](#)

Setting 2: External Reference 1/2 Selection

This function switches the Run command and frequency reference source between External reference 1 and 2 if the drive is in the REMOTE mode.

Status	Description
Open	External reference 1 is used (defined by parameters b1-01 and b1-02)
Closed	External reference 2 is used (defined by parameters b1-15 and b1-16)

Note: Default drive settings do not allow switching between External reference 1 and 2 during run. [Refer to b1-07: LOCAL/REMOTE Run Selection on page 169](#) if this feature is required by the application.

Setting 3 to 5: Multi-Step Speed Reference 1 to 3

Switches multi-step speed frequency references d1-01 to d1-08 by digital inputs. [Refer to d1: Frequency Reference on page 208](#) for details.

Setting 6: Jog Reference Selection

The Jog frequency set in parameter d1-17 becomes the frequency reference when the input terminal closes. [Refer to d1: Frequency Reference on page 208](#) for details.

Setting 7: Accel/Decel Time Selection 1

Switches between accel/decel times 1 (C1-01 and C1-02) and 2 (C1-03 and C1-04). [Refer to C1-01 to C1-08: Accel, Decel Times 1 to 4 on page 193](#) for details.

Setting 8, 9: Baseblock Command (N.O., N.C.)

When the drive receives a baseblock command, the output transistors stop switching, the motor coasts to stop, and a bb alarm flashes on the digital operator to indicate baseblock. When baseblock ends while a Run command is active, the drive performs Speed Search to restart the motor.

Digital Input Function	Drive Operation	
	Input Open	Input Closed
Setting 8 (N.C.)	Baseblock (Interrupt output)	Normal operation
Setting 9 (N.O.)	Normal operation	Baseblock (Interrupt output)

WARNING! Sudden Movement Hazard. When using a mechanical holding brake with the drive in a lifting application, close the brake when the drive output is cut off by a baseblock command triggered by one of the input terminals. Failure to comply will result in a slipping load from the motor suddenly coasting when the baseblock command is entered and may cause serious injury or death.

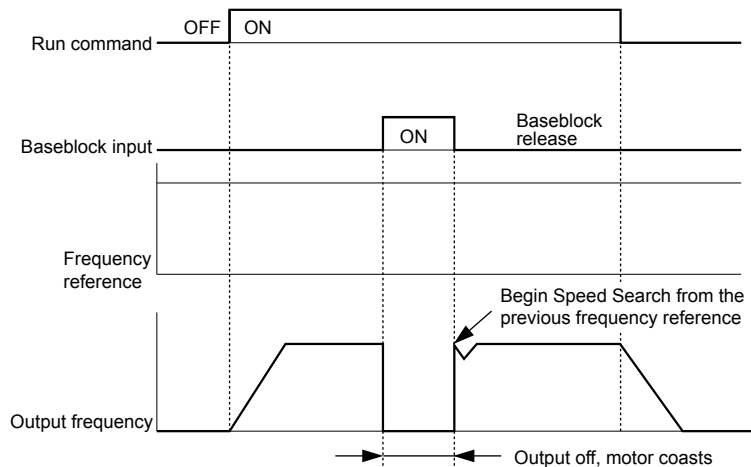

Figure 5.60 Baseblock Operation During Run

Setting A: Accel/Decel Ramp Hold

When the digital input programmed for the Accel/decel ramp hold function closes, the drive locks (holds) the output frequency. Acceleration or deceleration resumes when the input is reopened.

5.7 H: Terminal Functions

If the Accel/decel ramp hold function is enabled ($d4-01 = 1$), the drive saves the output frequency to memory when the Ramp Hold input is closed. When the drive is restarted after stop or after power supply interruption, the saved output frequency becomes the frequency reference (provided that the Accel/decel ramp hold input is still closed). [Refer to d4-01: Frequency Reference Hold Function Selection on page 212](#) for details.

Setting B: Drive Overheat Alarm (oH2)

Triggers an oH2 alarm when the contact closes. Drive operation is not affected because this is an alarm.

Setting C: Analog Terminal Input Selection (Terminal A1, A2, A3)

When closed, the terminals specified in H3-14 are enabled. When open, the drive disregards the input signal to the analog terminals.

Setting D: PG Encoder Disable

When closed, the drive disregards PG feedback from the motor when using V/f Control with PG. When the terminal is reopened, the drive resumes using PG feedback to control motor speed.

Setting E: ASR Integral Reset

Switches between PI control and P control by resetting the integral value. Integral operation is disabled when the terminal is closed and the drive uses P control. PI control resumes when the terminal opens.

Setting F: Through Mode

Select this setting when using the terminal in a pass-through mode. When set to F, an input does not trigger any function in the drive. Setting F, however, still allows the input status to be read out by a PLC via a communication option or MEMOBUS/Modbus communications.

Setting 10, 11: Up/Down Function

The Up/Down function allows the frequency reference to be set by two push buttons when one digital input is programmed as the Up input ($H1-\square\square = 10$) to increase the frequency reference and the other digital input is programmed as the Down input ($H1-\square\square = 11$) to decrease the frequency reference.

The Up/Down function takes priority over the frequency references from the digital operator, the analog inputs, and the pulse input ($b1-01 = 0, 1, 4$). When using the Up/Down function, references provided by these sources will be disregarded.

The inputs operate as shown in [Table 5.37](#):

Table 5.37 Up, Down Command

Status		Drive Operation
Up (10)	Down (11)	
Open	Open	Hold current frequency reference
Closed	Open	Increase frequency reference
Open	Closed	Decrease frequency reference
Closed	Closed	Hold current frequency reference

- Note:**
1. An oPE03 alarm occurs when only one of the Up/Down functions is programmed to a digital input.
 2. An oPE03 alarm occurs when the Up/Down function is assigned to the terminals and a different digital input is programmed for the Accel/decel ramp hold function. For more information on alarms, [Refer to Drive Alarms, Faults, and Errors on page 342](#).
 3. The Up/Down function can only be used for External reference 1. Consider this when using Up/Down and the external reference switching command ($H1-\square\square = 2$).

Using the Up/Down Function with Frequency Reference Hold (d4-01)

- If the frequency reference hold function is disabled ($d4-01 = 0$), the Up/Down frequency reference will be reset to 0 when the Run command is cleared or the power is cycled.
- When $d4-01 = 1$, the drive will save the frequency reference set by the Up/Down function. When the Run command or the power is cycled, the drive will restart with the saved reference value. Close the Up or Down input without an active Run command to reset the saved value. [Refer to d4-01: Frequency Reference Hold Function Selection on page 212](#).

Using the Up/Down Function with Frequency Reference Limits

Parameter d2-01 determines the upper frequency reference limit.

The value for the lower frequency reference limit depends on the parameter d4-10 setting. This value can be set by an analog input or parameter d2-02. [Refer to d4-10: Up/Down Frequency Reference Limit Selection on page 216](#) for details. When a Run command is applied, the lower limits function as follows:

- If the lower limit is set by d2-02 only, the drive accelerates to this limit as soon as a Run command is entered.
- If the lower limit is determined by an analog input only, the drive accelerates to the limit when both the Run command and an Up or Down command are active. The drive will not start running if only the Run command is active.

- If the lower limit is set by both an analog input and d2-02, and the analog limit is higher than the d2-02 value, the drive accelerates to the d2-02 value when a Run command is input. When the d2-02 value is reached, the drive accelerates to the analog limit only if an Up or Down command is set.

Figure 5.61 shows an Up/Down function example with a lower frequency reference limit set by d2-02, and the frequency reference hold function both enabled and disabled.

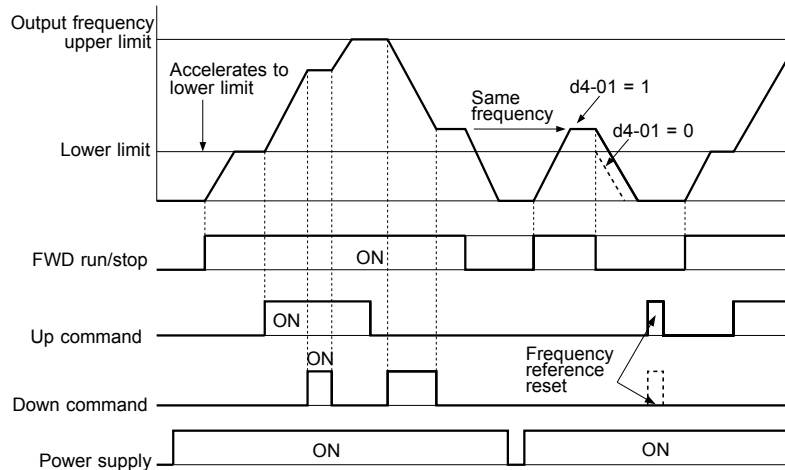

Figure 5.61 Up/Down Command Operation

Setting 12, 13: Forward Jog, Reverse Jog

Digital inputs programmed as Forward Jog (H1-□□ = 12) and Reverse Jog (H1-□□ = 13) will be Jog inputs that do not require a Run command. Closing the terminal set for Forward Jog input will cause the drive to ramp to the Jog frequency reference (d1-17) in the forward direction. The Reverse Jog will cause the same action in the reverse direction. The Forward Jog and Reverse Jog command can be set independently.

Note: The Forward Jog and Reverse Jog commands override all other frequency references. However, if the drive is set to prohibit reverse rotation (b1-04 = 1), activating Reverse Jog will have no effect. Inputting both the Forward Jog and Reverse Jog are simultaneously for 500 ms or longer will trigger an alarm and the drive will ramp to stop.

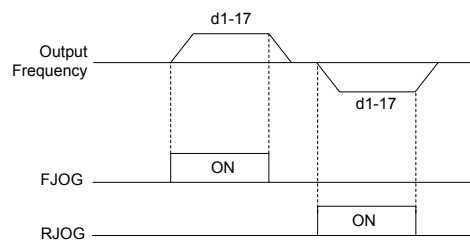

Figure 5.62 FJOG/RJOG Operation

Setting 14: Fault Reset

When the drive detects a fault condition, the fault output contact closes, the drive output shuts off, and the motor coasts to stop (specific stopping methods can be selected for some faults such as L1-04 for motor overheat). After removing the Run command, clear the fault either by pressing the RESET key on the digital operator or closing a digital input configured as a Fault Reset (H1-□□ = 14).

Note: Remove the Run command prior to resetting a fault. Fault Reset commands are ignored while the Run command is present.

Setting 15, 17: Fast Stop (N.O., N.C.)

The Fast Stop function operates similar to an emergency stop input to the drive. If a Fast Stop command is input while the drive is running, the drive decelerates to a stop in the deceleration time set to C1-09 (Refer to C1-09: Fast Stop Time on page 194). The drive can only be restarted after bringing the drive to a complete stop, turning off the Fast Stop input, and switching off the Run command.

- To trigger the Fast Stop function with an N.O. switch, set H1-□□ = 15.
- To trigger the Fast Stop function with an N.C. switch, set H1-□□ = 17.

Figure 5.63 shows an operation example of Fast Stop.

5.7 H: Terminal Functions

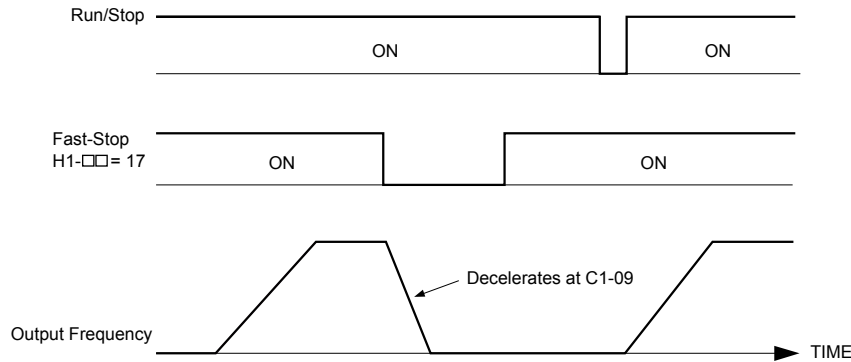

Figure 5.63 Fast Stop Sequence

NOTICE: Rapid deceleration can trigger an overvoltage fault. When faulted, the drive output shuts off, and the motor coasts. To avoid this uncontrolled motor state and to ensure that the motor stops quickly and safely, set an appropriate Fast Stop time to C1-09.

Setting 16: Motor 2 Selection

The drive has the capability to control two induction motors independently. A second motor may be selected using a multi-function digital input as shown in [Figure 5.64](#).

Note: The motor 2 selection function cannot be used with PM motors.

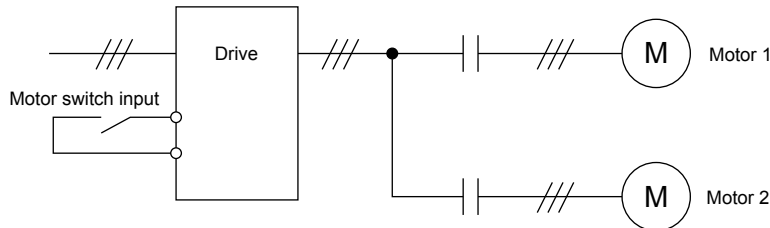

Figure 5.64 Motor Selection

When switching between motor 1 and motor 2, the parameters used to control those motors also change. Below, [Table 5.38](#) lists the parameters that correspond to each motor:

Table 5.38 Parameters for Switching Between Two Motors

No.	Setting 16 Open (Motor 1)	⇒	Setting 16 Closed (Motor 2)
C1-□□: Acceleration/Deceleration Time	C1-01 to C1-04	⇒	C1-05 to C1-08
C3-□□: Motor Slip Compensation	C3-01 to C3-04	⇒	C3-21 to C3-24
C4-□□: Motor Torque Compensation	C4-01	⇒	C4-07
C5-□□: Speed Control (ASR)	C5-01 to C5-08, C5-12, C5-17, C5-18	⇒	C5-21 to C5-28, C5-32, C5-37, C5-38
E1-□□, E3-□□: V/f Pattern E2-□□, E4-□□: Motor Parameters	E1-□□, E2-□□	⇒	E3-□□ to E4-□□
F1-□□ (PG Constant)	F1-01 to F1-21	⇒	F1-02 to F1-04, F1-08 to F1-11, F1-14, F1-31 to F1-37

- Note:**
1. When using 2 motors, the motor overload protection selection (oL1) set to L1-01 applies to both motor 1 and motor 2.
 2. Attempting to switch between motor 1 and motor 2 during run will trigger the rUn alarm.
 3. There is a 500 ms delay when switching between motors equipped with a PG encoder for feedback.
 4. The motor 2 selection function cannot be used with PM motors.

If a digital output is programmed for “Motor 2 selection” (H1-01, H1-02, or H1-03 = 1C), the motor will be selected when the output is closed.

Setting 18: Timer Function Input

This setting configures a digital input terminal as the input for the timer function. Use this setting combination with the timer function output (H2-□□ = 12). [Refer to b4: Delay Timers on page 178](#) for details.

Setting 19: PID Disable

Close a digital input to indefinitely disable the PID function. When the input is released, the drive resumes PID operation. *Refer to PID Block Diagram on page 181.*

Setting 1A: Accel/Decel Time Selection 2

Selects accel/decel times 1 to 4 in combination with the Accel/decel time selection 1 command. *Refer to C1-01 to C1-08: Accel, Decel Times 1 to 4 on page 193* for details.

Setting 1B: Program Lockout

Parameter values cannot be changed when an input is programmed for Program Lockout and the input is open. It is still possible, however, to view and monitor parameter settings.

Setting 1E: Reference Sample Hold

This function allows the user to sample an analog frequency reference signal being input to terminal A1, A2, or A3 and hold the frequency reference at the sampled level. When the Analog Frequency Reference Sample/Hold function is held for at least 100 ms, the drive reads the analog input and changes the frequency reference to the newly sampled speed as illustrated in *Figure 5.65*.

When the power is shut off and the sampled analog frequency reference is cleared, the frequency reference is reset to 0.

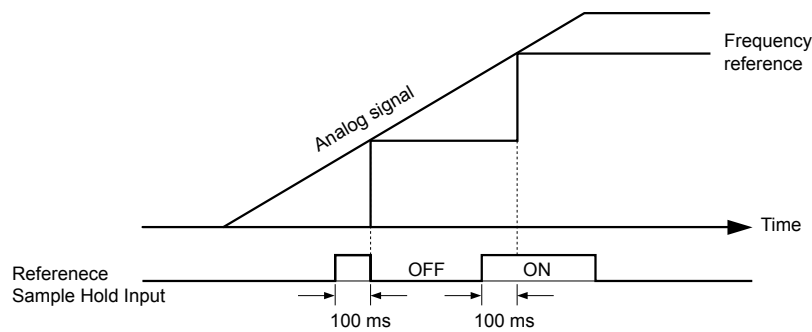

Figure 5.65 Analog Frequency Reference Sample/Hold

An oPE03 error will occur when one of the following functions is used simultaneously with the Analog frequency reference sample/hold command:

- Hold accel/decel stop (setting: A)
- Up command, Down command (setting: 10, 11)
- Offset frequency (setting: 44 to 46)
- Up or Down functions (setting: 75, 76)

Setting 20 to 2F: External Fault

The External fault command stops the drive when problems occur with external devices.

To use the External fault command, set one of the multi-function digital inputs to a value between 20 and 2F. The digital operator will display EF□ where □ is the number of the terminal to which the external fault signal is assigned.

For example, if an external fault signal is input to terminal S3, “EF3” will be displayed.

Select the value to be set in H1-□□ from a combination of any of the following three conditions:

- Signal input level from peripheral devices (N.O., N.C.)
- External fault detection method
- Operation after external fault detection

Table 5.39 shows the relationship between the conditions and the value set to H1-□□:

Terminal statuses, detection conditions, and stopping methods marked with an “O” are applicable to the corresponding settings.

5.7 H: Terminal Functions

Table 5.39 Stopping Method for External Fault

Setting	Terminal Status <1>		Detection Conditions <2>		Stopping Method			
	N.O.	N.C.	Always Detected	Detected during Run only	Ramp to Stop (fault)	Coast to Stop (fault)	Fast Stop (fault)	Alarm Only (continue running)
20	O		O		O			
21		O	O		O			
22	O			O	O			
23		O		O	O			
24	O		O			O		
25		O	O			O		
26	O			O		O		
27		O		O		O		
28	O		O				O	
29		O	O				O	
2A	O			O			O	
2B		O		O			O	
2C	O		O					O
2D		O	O					O
2E	O			O				O
2F		O		O				O

<1> Determine the terminal status for each fault, i.e., whether the terminal is normally open or normally closed.

<2> Determine whether detection for each fault should be enabled only during run or always detected.

Setting 30: PID Integral Reset

Configuring one of the digital inputs for PID integral reset (H1-□□ = 30) resets the value of the integral component in PID control to 0 when the terminal is closed. [Refer to PID Block Diagram on page 181](#) for more details.

Setting 31: PID Integral Hold

Configuring a digital input for Integral Hold (H1-0□ = 31) locks the value of the integral component of the PID control as long as the input is active. The PID controller resumes integral operation from the hold value as soon as the integral hold input is released. [Refer to PID Block Diagram on page 181](#) for more information on this function.

Setting 32: Multi-Step Speed Reference 4

Selects the multi-step speeds d1-09 to d1-16 in combination with the input terminal set for Multi-Step Speed 1, 2 and 3. [Refer to d1-01 to d1-17: Frequency Reference 1 to 16 and Jog Frequency Reference on page 208.](#)

Setting 34: PID Soft Starter Cancel

A digital input configured as a PID soft starter cancel input (H1-0□ = 34) enables or disables the PID soft starter and cancels the PID accel/decel time (b5-17). [Refer to PID Block Diagram on page 181.](#)

Setting 35: PID Input Level Selection

Allows an input terminal to switch the sign of the PID input. [Refer to PID Block Diagram on page 181](#) for details.

Setting 40, 41: Forward Run, Reverse Run Command for 2-Wire Sequence

Configures the drive for a 2-Wire sequence.

When an input terminal set to 40 closes, the drive operates in the forward direction. When an input set for 41 closes, the drive operates in reverse. Closing both inputs simultaneously will result in an external fault.

- Note:**
1. This function cannot be used simultaneously with settings 42 and 43.
 2. The same functions are assigned to terminals S1 and S2 when the drive is initialized for 2-Wire sequence.

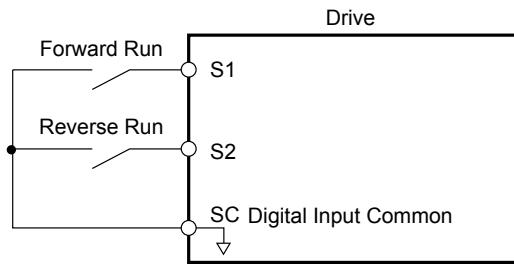

Figure 5.66 Example Wiring Diagram for 2-Wire Sequence

Setting 42, 43: Run and Direction Command for 2-Wire Sequence 2

Sets the drive for 2-Wire sequence 2.

When an input terminal programmed for 42 closes, the drive will operate in the selected direction. The drive will stop when the input opens.

The input programmed for 43 selects the direction. If the input is open, forward direction is selected. If the input is closed, reverse direction is selected.

Note: This function cannot be used simultaneously with settings 40 and 41.

Setting 44, 45, 46: Offset Frequency 1, 2, 3

These inputs add offset frequencies d7-01, d7-02, and d7-03 to the frequency reference. [Refer to d7-01 to d7-03: Offset Frequency 1 to 3 on page 222](#) for details.

Setting 47: Node Setup

If the SI-S3 option card is connected, closing this terminal sets a node address for operation on a CANopen network.

Setting 60: DC Injection Braking Command

DC Injection Braking is activated when a DC Injection Braking command is input while the drive is stopped. DC Injection Braking is released when a Run command or a Jog command is input. [Refer to b2: DC Injection Braking and Short Circuit Braking on page 170](#) for details on setting up the DC Injection Braking function.

The diagram below illustrates DC Injection Braking:

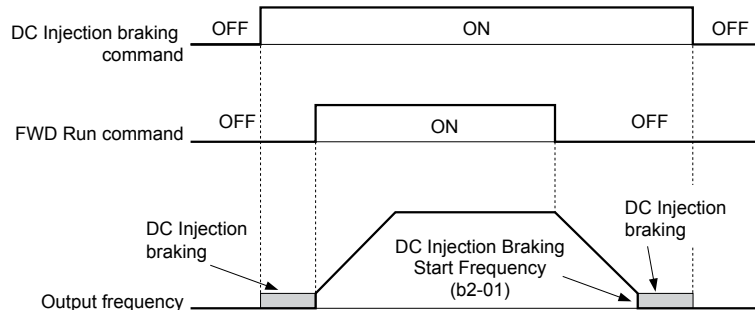

Figure 5.67 DC Injection Braking Input Timing Diagram

Setting 61, 62: External Speed Search Command 1, 2

These input functions enable Speed Search even if parameter b3-01 = 0 (no Speed Search at start). [Refer to Speed Search Activation on page 175](#) for details on how to use the input signals. [Refer to b3: Speed Search on page 173](#) for more about Speed Search.

Note: Simultaneously assigning Speed Search 1 and Speed Search 2 to the input terminals will trigger an oPE03 error.

Setting 63: Field Weakening

Enabled in V/f Control. When this input is closed, Field Weakening is performed. For details, see [d6: Field Weakening and Field Forcing](#).

Setting 65, 66: KEB Ride-Thru 1 (N.C.), 2 (N.O.)

Enables the KEB Ride-Thru function selected in parameter L2-29. [Refer to KEB Ride-Thru Function on page 287](#) for more information on this function.

5.7 H: Terminal Functions

Digital Input Function	Drive Operation	
	Input Open	Input Closed
Setting 65 (N.C.)	KEB Ride-Thru Deceleration	Normal operation
Setting 66 (N.O.)	Normal operation	KEB Ride-Thru Deceleration

Note: Simultaneously assigning KEB Ride-Thru 1 and KEB Ride-Thru 2 to the input terminals will trigger an oPE03 error.

Setting 67: Communication Test Mode

The drive has a built-in function to self-diagnose serial communications operation. The test involves wiring the send and receive terminals of the RS-485/422 port together. The drive transmits data and then confirms that the communications are received normally. [Refer to Self-Diagnostics on page 643](#) for details on how to use this function.

Setting 68: High Slip Braking (HSB)

Closing an input programmed for this function triggers High Slip Braking (available only in V/f and V/f w/PG control modes). After starting HSB, bring the drive to a complete stop and remove the HSB command before restarting. [Refer to n3: High Slip Braking \(HSB\) and Overexcitation Braking on page 314](#).

Setting 6A: Drive Enable

A digital input configured as a “Drive enable” (H1-□□ = 6A) will prevent the drive from executing a Run command until the input is closed. When the input is open, the digital operator will display “dnE” to indicate that the drive is disabled.

If a Run command is enabled before the terminal set for “Drive enable” closes, then the drive will not run until the Run command is cycled (i.e., a new Run command is required). If the input is opened while the drive is running, the drive will stop according to the stop method set to b1-03 ([Refer to b1-03: Stopping Method Selection on page 164](#)).

Setting 71: Speed/Torque Control Switch

Switches the drive between Torque Control and Speed Control. Torque Control is enabled when the terminal is closed, and Speed Control is enabled when the terminal is open. Set parameter d5-01 to 0 when using this function. [Refer to d5: Torque Control on page 217](#) and [Switching Between Torque and Speed Control on page 219](#).

Setting 72: Zero Servo

Activates the Zero Servo function to lock the rotor at a certain position. [Refer to b9: Zero Servo on page 192](#) for details.

Setting 75, 76: Up 2/Down 2 Function

The Up/Down 2 function adds a bias to the frequency reference. The input programmed for 75 will increase the bias and the input programmed for 76 will decrease the bias. [Table 5.40](#) explains how the Up/Down 2 function works depending on the frequency reference source and parameters d4-01, d5-03, and d4-05. [Refer to d4: Frequency Reference Hold and Up/Down 2 Function on page 212](#) for detailed explanations of these and other Up/Down 2 related parameters.

- Note:**
1. The Up/Down 2 functions must be set as a pair.
 2. When using the Up/Down 2 function, set appropriate bias limit values to parameters d4-08 and d4-09.

Table 5.40 Up/Down 2 Operations

Condition	Freq. Ref. Source	d4-03	d4-05	d4-01	Operation	Frequency Saved
1	Multi-Step Speed Reference	0	0	0	<ul style="list-style-type: none"> Accelerates (increases the bias) while the Up 2 terminal is closed. Decelerates (decreases the bias) while Down 2 is closed. 	Not saved
2				1		<ul style="list-style-type: none"> Holds output frequency (holds the bias) when no Up 2 or Down 2 input or both active. Resets the bias when the reference changes. Operates with the frequency reference in all other situations.
3				1	--	<ul style="list-style-type: none"> Accelerates (increases the bias) while the Up 2 terminal is closed. Decelerates (decreases the bias) while Down 2 is closed. Otherwise operates at the frequency reference.

Condition	Freq. Ref. Source	d4-03	d4-05	d4-01	Operation	Frequency Saved
4	Multi-Step Speed Reference	Value other than 0	--	0	<ul style="list-style-type: none"> When the Up 2 is enabled, the drive accelerates to the frequency reference plus d4-03 (bias is increased for d4-03). When Down 2 is enabled, the drive decelerates to the frequency reference minus d4-03 (bias is decreased for d4-03). Holds output frequency (holds the bias) when neither Up/Down 2 inputs are active or both inputs are active. Resets the bias when the reference changes. Operates with the frequency reference in all other situations. 	Not saved
5				1		If the bias and frequency reference are constant for 5 s, the bias is added to the active frequency reference and reset afterwards.
6	Other (analog comm., etc.)	0	0	0	<ul style="list-style-type: none"> Accelerates (increases the bias) while the Up 2 terminal is closed. Decelerates (decreases the bias) while Down 2 is closed. Holds output frequency (holds the bias) when neither Up/Down 2 inputs are active or both inputs are active. If the frequency reference changes for more than the time set to d4-07 during accel/decel, bias value is held until the output frequency meets the reference (speed agree). 	Not saved
7				1		If the bias is constant for 5 s, it is saved to parameter d4-06. The frequency reference cannot be overwritten, so only the bias is saved.
8	Other (analog comm., etc.)	0	1	--	<ul style="list-style-type: none"> Accelerates (increases the bias) while the Up 2 terminal is closed. Decelerates (decreases the bias) while Down 2 is closed. Otherwise operates at the frequency reference 	Not saved
9				0		Not saved
10	Other (analog comm., etc.)	Value other than 0	--	1	<ul style="list-style-type: none"> When Up 2 is enabled, drive accelerates to the frequency reference plus d4-03 (increases the bias for d4-03). When Down 2 is enabled, drive decelerates to the frequency reference minus d4-03 (decreases the bias for d4-03). If the frequency reference changes for more than d4-07 during accel/decel, bias value is held until the output frequency meets the reference (speed agree). 	If the bias is constant for 5 s, it is saved to parameter d4-06. The frequency reference cannot be overwritten, so only the bias is saved.
10				1		If the bias is constant for 5 s, it is saved to parameter d4-06. The frequency reference cannot be overwritten, so only the bias is saved.

Setting 77: ASR Gain Switch

Switches the ASR gain between the values set to C5-01 and C5-03. The gain set to C5-03 is enabled when the terminal is closed, and C5-01 is enabled when the terminal reopens. *Refer to C5-01, C5-03/C5-02, C5-04: ASR Proportional Gain 1, 2/ ASR Integral Time 1, 2 on page 202* for a more detailed description.

Setting 78: External Torque Reference Polarity Inversion

Reverses the direction of the torque reference when the terminal closes. *Refer to d5: Torque Control on page 217* and *Setting the Torque Reference, Speed Limit, and Torque Compensation Values on page 217* for details.

Setting 7A, 7B: KEB Ride-Thru 2 (N.C., N.O.)

An input terminal set to 7A or 7B can trigger Single Drive KEB Ride-Thru during deceleration. L2-29 is disregarded if this is enabled. *Refer to KEB Ride-Thru Function on page 287* for details.

Digital Input Function	Drive Operation	
	Input Open	Input Closed
Setting 7A (N.C.)	Single Drive KEB Ride-Thru 2	Normal operation
Setting 7B (N.O.)	Normal operation	Single Drive KEB Ride-Thru 2

Note: Simultaneously assigning KEB Ride-Thru 1 and KEB Ride-Thru 2 to the input terminals will trigger an oPE03 error.

Setting 7C, 7D: Short Circuit Braking (N.O., N.C.) (OLV/PM, AOLV/PM)

Note: PM motor control modes are not available on 600 V class drives, models 5A□□□□.

Activates Short Circuit Braking in OLV control modes for PM motors. By linking all three phases of a PM motor, Short Circuit Braking creates a braking torque to stop a rotating motor or prevent a motor from coasting due to external forces (such as the windmill effect in fan applications). Parameter b2-18 limits the current during Short Circuit Braking.

5.7 H: Terminal Functions

Digital Input Function	Drive Operation	
	Input Open	Input Closed
Setting 7C (N.O.)	Normal operation	Short Circuit Braking
Setting 7D (N.C.)	Short-Circuit Braking	Normal operation

Setting 7E: Forward/Reverse Detection (for V/f Control with Simple PG Feedback)

Determines the motor rotation direction for V/f Control with Simple PG feedback (A1-02 = 0 and H6-01 = 3). If the input is open, the speed feedback signal is considered to be forward. If the input is closed, it is considered to be reverse. *Refer to H6: Pulse Train Input/Output on page 276.*

Setting 90 to 97: DriveWorksEZ Digital Input 1 to 8

These settings are for digital input functions used in DriveWorksEZ. Changing these settings is not typically required.

Setting 9F: DriveWorksEZ Disable

This function is used to enable or disable a DriveWorksEZ program in the drive. An input programmed for this function is effective only if A1-07 = 2.

Status	Description
Open	DriveWorksEZ enabled
Closed	DriveWorksEZ disabled

◆ H2: Multi-Function Digital Outputs

■ H2-01 to H2-03: Terminal M1-M2, M3-M4, and M5-M6 Function Selection

The drive has three multi-function output terminals. *Table 5.41* lists the functions available for these terminals using H2-01, H2-02, and H2-03.

No.	Parameter Name	Setting Range	Default
H2-01	Terminal M1-M2 Function Selection (relay)	0 to 192	0: During run
H2-02	Terminal M3-M4 Function Selection (relay)	0 to 192	1: Zero Speed
H2-03	Terminal M5-M6 Function Selection (relay)	0 to 192	2: Speed agree 1

Table 5.41 Multi-Function Digital Output Terminal Settings

Setting	Function	Page	Setting	Function	Page
0	During Run	259	16	Frequency Detection 4	264
1	Zero Speed	259	17	Torque Detection 1 (N.C.)	262
2	Speed Agree 1	259	18	Torque Detection 2 (N.O.)	
3	User-Set Speed Agree 1	260	19	Torque Detection 2 (N.C.)	262
4	Frequency Detection 1	260	1A	During Reverse	264
5	Frequency Detection 2	261	1B	During Baseblock (N.C.)	265
6	Drive Ready	261	1C	Motor 2 Selection	265
7	DC Bus Undervoltage	261	1D	During regeneration	265
8	During Baseblock (N.O.)	262	1E	Restart Enabled	265
9	Frequency Reference Source	262	1F	Motor Overload Alarm (oL1)	265
A	Run Command Source	262	20	Drive Overheat Pre-Alarm (oH)	265
B	Torque Detection 1 (N.O.)	262	22	Mechanical Weakening Detection	265
C	Frequency Reference Loss	262	2F	Maintenance Period	265
D </>	Braking Resistor Fault	262	30	During Torque Limit	265
E	Fault	262	31	During Speed Limit	266
F	Through Mode	262	32	During Speed Limit in Torque Control	266
10	Minor Fault	262	33	Zero Servo Complete	266
11	Fault Reset Command Active	262	37	During Frequency Output	266
12	Timer Output	263	38	Drive Enabled	266
13	Speed Agree 2	263	39	Watt Hour Pulse Output	266
14	User-Set Speed Agree 2	263	3C	LOCAL/REMOTE Status	266
15	Frequency Detection 3	264	3D	During Speed Search	267

Setting	Function	Page
3E	PID Feedback Low	267
3F	PID Feedback High	267
4A	During KEB Operation	267
4B	During Short Circuit Braking	267
4C	During Fast Stop	267
4D	oH Pre-Alarm Time Limit	267
4E <2>	Braking Transistor Fault (rr)	267
4F <2>	Braking Resistor Overheat (rH)	267

Setting	Function	Page
60	Internal Cooling Fan Alarm	267
61	Rotor Position Detection Completed	267
90	DriveWorksEZ Digital Output 1	267
91	DriveWorksEZ Digital Output 2	
92	DriveWorksEZ Digital Output 3	
100 to 192	Functions 0 to 92 with Inverse Output	267

<1> Not available in models 4A0930 and 4A1200.

<2> Not available in models 2A0169 to 2A0415 and 4A0088 to 4A1200.

Setting 0: During Run

Output closes when the drive is outputting a voltage.

Status	Description
Open	Drive is stopped.
Closed	A Run command is input or the drive is in deceleration or DC injection.

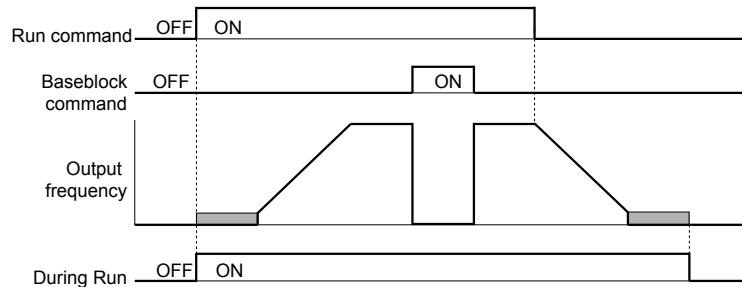

Figure 5.68 During Run Time Chart

Setting 1: Zero Speed

Terminal closes when the output frequency or motor speed (CLV, CLV/PM) falls below the minimum output frequency set to E1-09 or b2-01.

Status	Description
Open	Output frequency is above the minimum output frequency set to E1-09 or b2-01
Closed	Output frequency is less than the minimum output frequency set to E1-09 or b2-01

Note: In CLV and CLV/PM control modes, the zero speed level is defined by b2-01. In all other control modes, the zero speed level is the minimum output frequency set to E1-09.

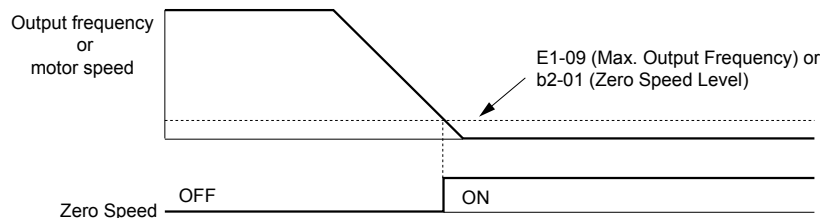

Figure 5.69 Zero-Speed Time Chart

Setting 2: Speed Agree 1 (f_{ref}/f_{out} Agree 1)

Closes when the actual output frequency or motor speed (CLV, CLV/PM) is within the Speed Agree Width (L4-02) of the current frequency reference regardless of the direction.

Status	Description
Open	Output frequency or motor speed does not match the frequency reference while the drive is running.
Closed	Output frequency or motor speed is within the range of frequency reference ±L4-02.

Note: Detection works in forward and reverse.

5.7 H: Terminal Functions

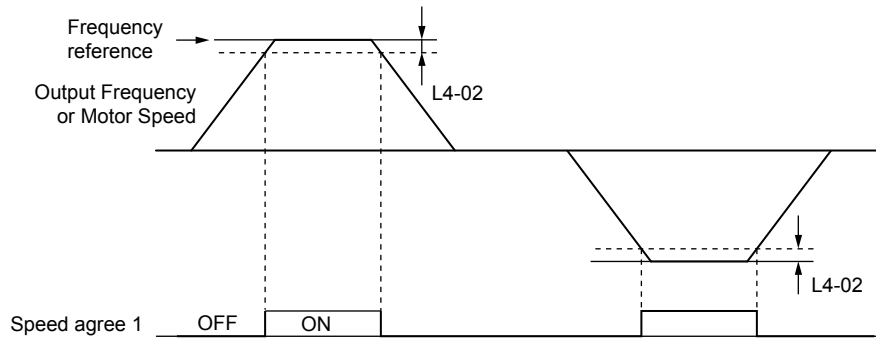

Figure 5.70 Speed Agree 1 Time Chart

Refer to L4-01, L4-02: Speed Agreement Detection Level and Detection Width on page 300 for more details.

Setting 3: User-Set Speed Agree 1 (f_{ref}/f_{set} Agree 1)

Closes when the actual output frequency or motor speed (CLV, CLV/PM) and the frequency reference are within the speed agree width (L4-02) of the programmed speed agree level (L4-01).

Status	Description
Open	Output frequency or motor speed and frequency reference are not both within the range of $L4-01 \pm L4-02$.
Closed	Output frequency or motor speed and the frequency reference are both within the range of $L4-01 \pm L4-02$.

Note: Frequency detection works in forward and reverse. The value of L4-01 is used as the detection level for both directions.

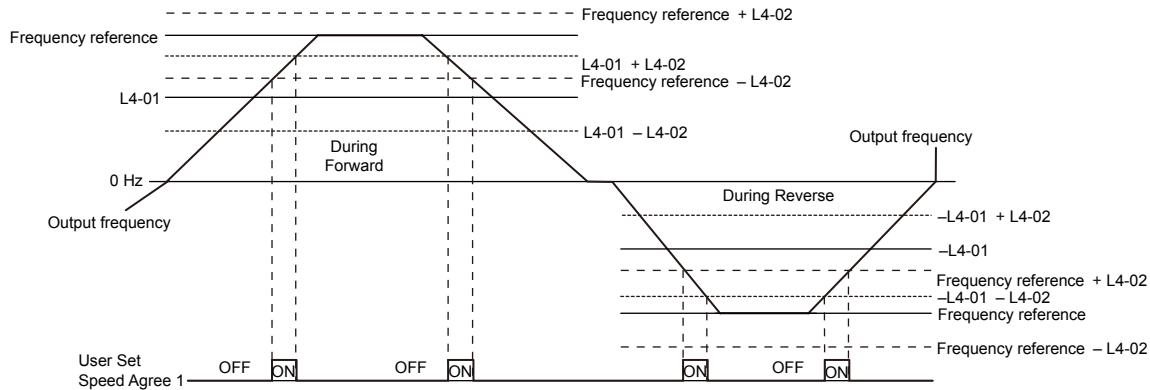

Figure 5.71 User Set Speed Agree 1 Time Chart

Refer to L4-01, L4-02: Speed Agreement Detection Level and Detection Width on page 300 for more instructions.

Setting 4: Frequency Detection 1

The output opens when the output frequency or motor speed (CLV, CLV/PM) rises above the detection level set in L4-01 plus the detection width set in L4-02. The terminal remains open until the output frequency or motor speed fall below the level set in L4-01.

Status	Description
Open	Output frequency or motor speed exceeded $L4-01 + L4-02$.
Closed	Output frequency or motor speed is below L4-01 or has not exceeded $L4-01 + L4-02$.

Note: Frequency detection works in forward and reverse. The value of L4-01 is used as the detection level for both directions.

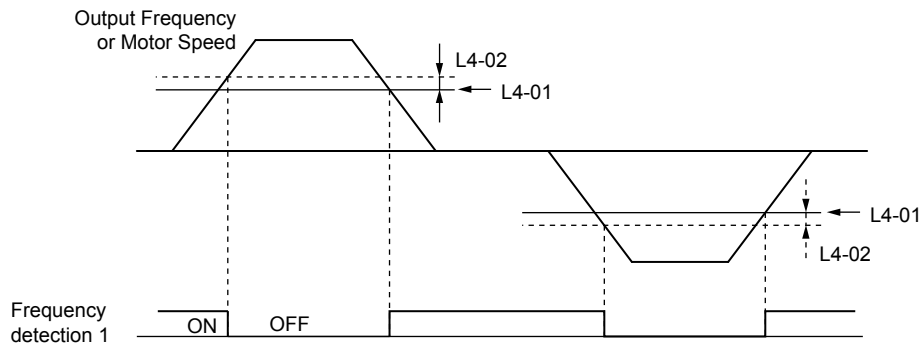

Figure 5.72 Frequency Detection 1 Time Chart

Refer to L4-01, L4-02: Speed Agreement Detection Level and Detection Width on page 300 for more details.

Setting 5: Frequency Detection 2

The output closes when the output frequency or motor speed (CLV, CLV/PM) is above the detection level set in L4-01. The terminal remains closed until the output frequency or motor speed fall below L4-01 minus the setting of L4-02.

Status	Description
Open	Output frequency or motor speed is below L4-01 minus L4-02 or has not exceeded L4-01.
Closed	Output frequency or motor speed exceeded L4-01.

Note: Frequency detection works in forward and reverse. The value of L4-01 is used as the detection level for both directions.

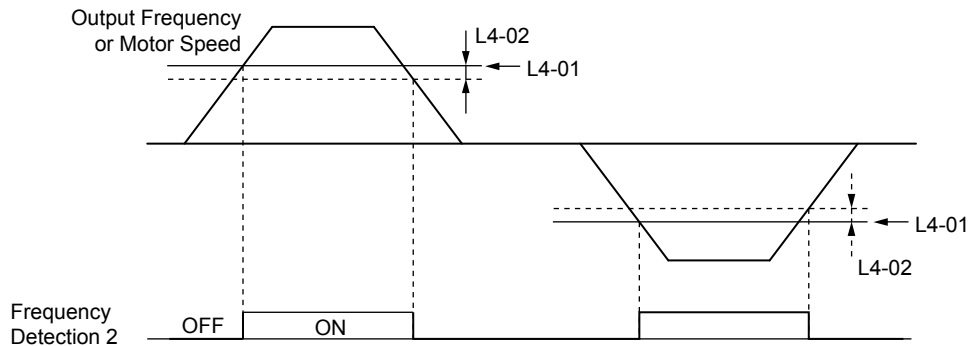

Figure 5.73 Frequency Detection 2 Time Chart

Refer to L4-01, L4-02: Speed Agreement Detection Level and Detection Width on page 300 for more details.

Setting 6: Drive Ready

The output closes when the drive is ready to operate the motor. The terminal will not close under the conditions listed below, and any Run commands will be disregarded.

- When the power is shut off
- During a fault
- When the internal power supply of the drive has malfunctioned
- When a parameter setting error makes it impossible to run
- Although stopped, an overvoltage or undervoltage situation occurs
- While editing a parameter in the Programming Mode (when b1-08 = 0)

Setting 7: DC Bus Undervoltage

The output closes when the DC bus voltage or control circuit power supply drops below the trip level set in L2-05. A fault in the DC bus circuit will also cause the terminal set for “DC bus undervoltage” to close.

Status	Description
Open	DC bus voltage is above the level set to L2-05.
Closed	DC bus voltage has fallen below the trip level set to L2-05.

5.7 H: Terminal Functions

Setting 8: During Baseblock (N.O.)

The output closes to indicate that the drive is in a baseblock state. While in baseblock, output transistors do not switch and no main circuit voltage is output.

Status	Description
Open	Drive is not in a baseblock state.
Closed	Baseblock is being executed.

Setting 9: Frequency Reference Source

Displays the currently selected frequency reference source.

Status	Description
Open	Frequency reference is provided from External reference 1 (b1-01) or External reference 2 (b1-15).
Closed	Frequency reference is being sourced from the digital operator.

Setting A: Run Command Source

Displays the currently selected Run command source.

Status	Description
Open	Run command is provided from External reference 1 (b1-02) or 2 (b1-16).
Closed	Run command is being sourced from the digital operator.

Setting B, 17, 18, 19: Torque Detection 1 (N.O., N.C.), Torque Detection 2 (N.O., N.C.)

These digital output functions signal an overtorque or undertorque situation to an external device.

Set up the torque detection levels and select the output function from the table below. [Refer to L6: Torque Detection on page 302](#) for details.

Setting	Status	Description
B	Closed	Torque detection 1 (N.O.): Output current/torque exceeds (overtorque detection) or is below (undertorque detection) the torque value set in parameter L6-02 for longer than the time specified in parameter L6-03.
17	Open	Torque detection 1 (N.C.): Output current/torque exceeds (overtorque detection) or is below (undertorque detection) the torque value set in parameter L6-02 for longer than the time specified in parameter L6-03.
18	Closed	Torque detection 2 (N.O.): Output current/torque exceeds (overtorque detection) or is below (undertorque detection) the torque value set in parameter L6-05 for longer than the time specified in parameter L6-06.
19	Open	Torque detection 2 (N.C.): Output current/torque exceeds (overtorque detection) or is below (undertorque detection) the torque value set in parameter L6-05 for longer than the time specified in parameter L6-06.

Setting C: Frequency Reference Loss

An output set for this function closes when frequency reference loss is detected. [Refer to L4-05: Frequency Reference Loss Detection Selection on page 300](#) for details.

Setting D: Braking Resistor Fault

An output programmed for this function closes when the dynamic braking resistor (DB) overheats or the braking transistor is in a fault condition.

Setting E: Fault

The output closes when the drive faults (excluding CPF00 and CPF01 faults).

Setting F: Through Mode

Select this setting when using the terminal in a pass-through mode. When set to F, an output does not trigger any function in the drive. Setting F, however, still allows the output status to be read by a PLC via a communication option or MEMOBUS/Modbus communications.

Setting 10: Minor Fault

The output closes when a minor fault condition is present.

Setting 11: Fault Reset Command Active

The output closes when there is an attempt to reset a fault situation from the control circuit terminals, via serial communications, or using a communications option card.

Setting 12: Timer Output

This setting configures a digital output terminal as the output for the timer function. *Refer to b4: Delay Timers on page 178* for details.

Setting 13: Speed Agree 2 (f_{ref}/f_{out} Agree 2)

The output closes when the actual output frequency or motor speed (CLV, CLV/PM) is within the speed agree width (L4-04) of the current frequency reference, regardless of the direction.

Status	Description
Open	Output frequency or motor speed does not match the frequency reference while the drive is running.
Closed	Output frequency or motor speed is within the range of frequency reference $\pm L4-04$.

Note: Detection works in forward and reverse.

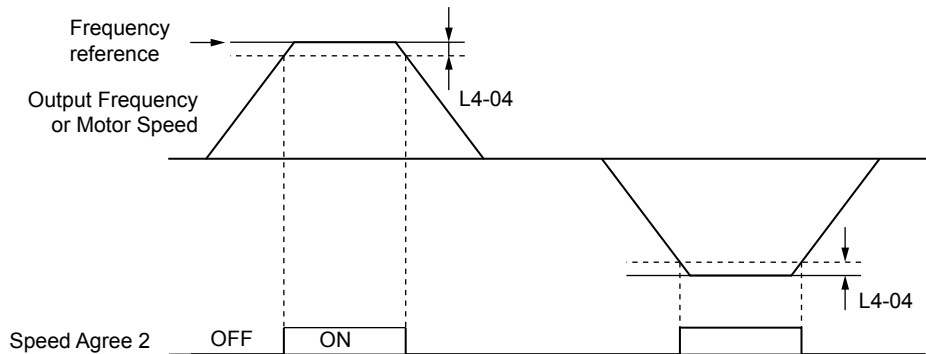

Figure 5.74 Speed Agree 2 Time Chart

Refer to L4-03, L4-04: Speed Agreement Detection Level and Detection Width (+/-) on page 300 for more details.

Setting 14: User-Set Speed Agree 2 (f_{ref}/f_{set} Agree 2)

The output closes when the actual output frequency or motor speed (CLV, CLV/PM) and the frequency reference are within the speed agree width (L4-04) of the programmed speed agree level (L4-03).

Status	Description
Open	Output frequency or motor speed and frequency reference are both outside the range of $L4-03 \pm L4-04$.
Closed	Output frequency or motor speed and the frequency reference are both within the range of $L4-03 \pm L4-04$.

Note: The detection level L4-03 is a signed value; detection works in the specified direction only.

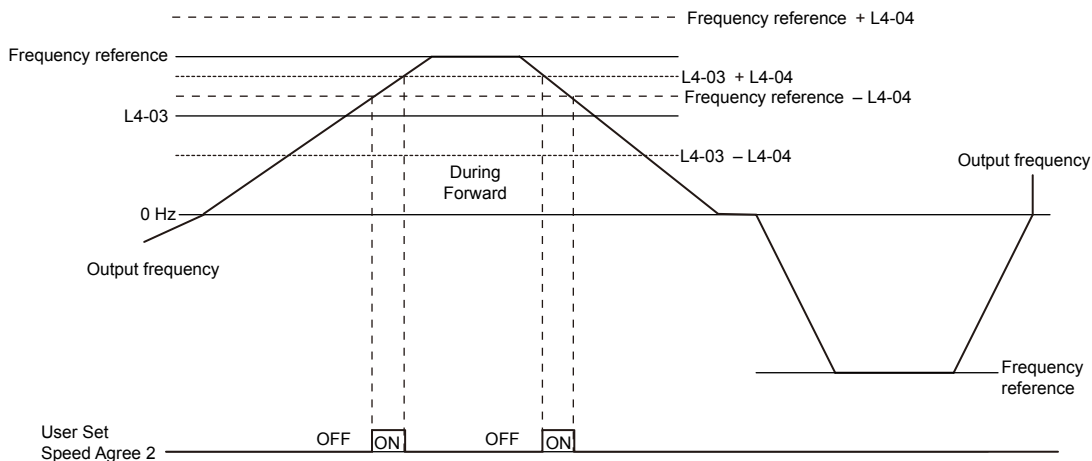

Figure 5.75 User-Set Speed Agree 2 Example with a Positive L3-04 Value

Refer to L4-03, L4-04: Speed Agreement Detection Level and Detection Width (+/-) on page 300 for more details.

5.7 H: Terminal Functions

Setting 15: Frequency Detection 3

The output opens when the output frequency or motor speed (CLV, CLV/PM) rises above the detection level set in L4-03 plus the detection with set in L4-04. The terminal remains open until the output frequency or motor speed falls below the level set in L4-03. The detection level L4-03 is a signed value; detection works in the specified direction only.

Status	Description
Open	Output frequency or motor speed exceeded L4-03 plus L4-04.
Closed	Output frequency or motor speed is below L4-03 or has not exceeded L4-03 plus L4-04.

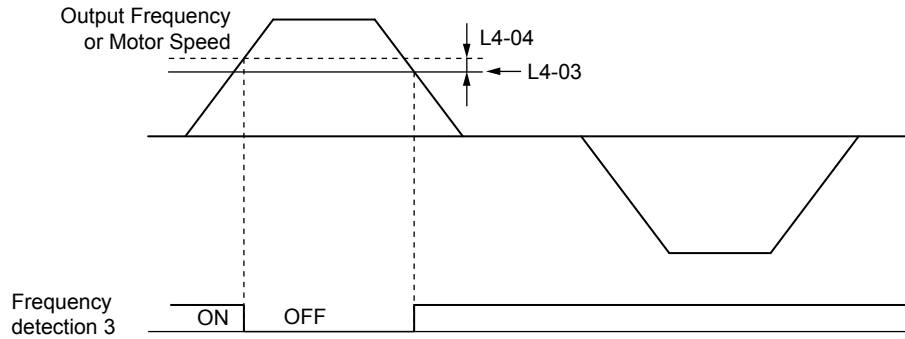

Figure 5.76 Frequency Detection 3 Example with a Positive L3-04 Value

Refer to L4-03, L4-04: Speed Agreement Detection Level and Detection Width (+/-) on page 300 for more details.

Setting 16: Frequency Detection 4

The output closes when the output frequency or motor speed (CLV, CLV/PM) is above the detection level set in L4-03. The terminal remains closed until the output frequency or motor speed falls below L4-03 minus the setting of L4-04.

Status	Description
Open	Output frequency or motor speed is below L4-03 minus L4-04 or has not exceeded L4-03.
Closed	Output frequency or motor speed exceeded L4-03.

Note: The detection level L4-03 is a signed value; detection works in the specified direction only.

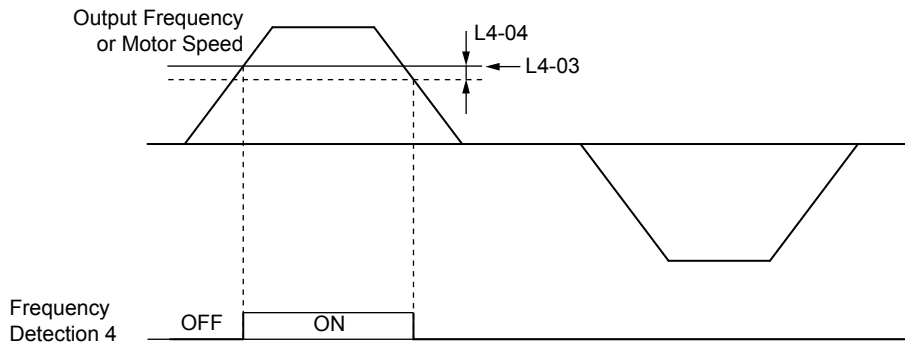

Figure 5.77 Frequency Detection 4 Example with Positive L3-04 Value

Refer to L4-03, L4-04: Speed Agreement Detection Level and Detection Width (+/-) on page 300 for more details.

Setting 1A: During Reverse

A digital output set for “During reverse” closes when the drive is running the motor in the reverse direction.

Status	Description
Open	Motor is being driven in the forward direction or stopped.
Closed	Motor is being driven in reverse.

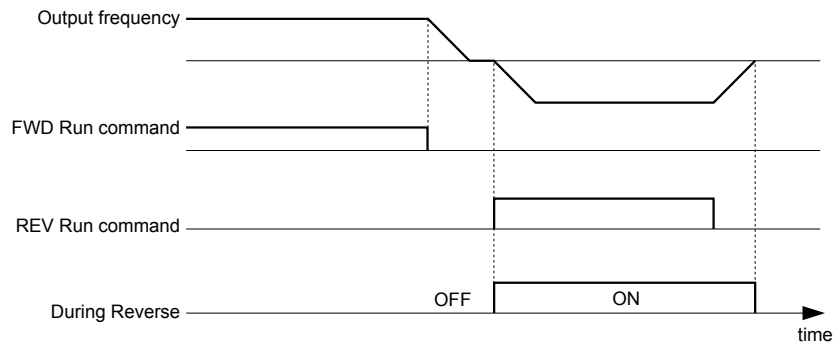

Figure 5.78 Reverse Direction Output Example Time Chart

Setting 1B: During Baseblock (N.C.)

The output opens to indicate that the drive is in a baseblock state. While Baseblock is executed, output transistors do not switch and no main circuit voltage is output.

Status	Description
Open	Baseblock is being executed.
Closed	Drive is not in a baseblock state.

Setting 1C: Motor 2 Selection

Indicates which motor is selected when another output terminal is set to switch drive operation between two motors (H1-□□ = 16). [Refer to Setting 16: Motor 2 Selection on page 252](#) for details on switching motors.

Status	Description
Open	Motor 1 is selected.
Closed	Motor 2 is selected.

Setting 1D: During Regeneration

Terminal closes when the motor is driven in the regenerative mode.

Setting 1E: Restart Enabled

An output set for “Restart enabled” closes when the drive attempts to restart after a fault has occurred.

The fault restart function allows the drive to automatically clear a fault. The terminal set to 1E will close after the fault is cleared and the drive has attempted to restart. If the drive cannot successfully restart within the number of attempts permitted by L5-01, a fault will be triggered and the terminal set to 1E will open. [Refer to L5: Fault Restart on page 301](#) for details on automatic restart.

Setting 1F: Motor Overload Alarm (oL1)

The output closes when the motor overload level estimated by the oL1 fault detection exceeds 90% of the oL1 detection level. [Refer to L1-01: Motor Overload Protection Selection on page 279](#).

Setting 20: Drive Overheat Pre-Alarm (oH)

The output closes when the drive heatsink temperature reaches the level specified by parameter L8-02. [Refer to L8-02: Overheat Alarm Level on page 306](#) for details on drive overheat detection.

Setting 22: Mechanical Weakening Detection

The output closes when a mechanical weakening situation is detected. [Refer to Mechanical Weakening Detection on page 304](#) for details.

Setting 2F: Maintenance Period

The output closes when the cooling fan, DC bus capacitors, or DC bus pre-charge relay may require maintenance as determined by the estimated performance life span of those components. Components performance life is displayed as a percentage on the digital operator screen. [Refer to Periodic Maintenance on page 403](#).

Setting 30: During Torque Limit

Note: PM motor control modes are not available on 600 V class drives, models 5A□□□□.

5.7 H: Terminal Functions

The output closes when the motor is operating at the torque limit specified by the L7-□□ parameters or an analog input. This setting can only be used in OLV, CLV, AOLV/PM and CLV/PM control modes. *Refer to L7-01 to L7-04: Torque Limits on page 305* for details.

Setting 31: During Speed Limit

Note: PM motor control modes are not available on 600 V class drives, models 5A□□□□.

The output closes when the speed limit has been reached. This function can be used in CLV and CLV/PM control modes.

Status	Description
Open	The conditions described below are not present.
Closed	<ol style="list-style-type: none"> The frequency reference has reached the upper limit set in d2-01. The frequency reference has fallen to the lower limit set in d2-02 or d2-03. Parameter b1-05 is set to 1, 2, or 3, and the frequency reference has fallen below the minimum output frequency (E1-09).

Setting 32: During Speed Limit in Torque Control

The motor torque and load torque are not in balance, causing the motor to accelerate. The output closes when the motor reaches the speed limit. *Refer to d5: Torque Control on page 217* and *Indicating Operation at the Speed Limit on page 219* for details.

Setting 33: Zero Servo Complete

The output closes when Zero Servo is enabled and the load is locked into position within the allowable deviation (b9-02). *Refer to b9: Zero Servo on page 192* for information on Zero Servo operation.

Setting 37: During Frequency Output

The output closes when the drive is outputting a frequency.

Status	Description
Open	Drive is stopped or one of the following functions is being performed: baseblock, DC Injection Braking, Short Circuit Braking.
Closed	Drive is outputting frequency.

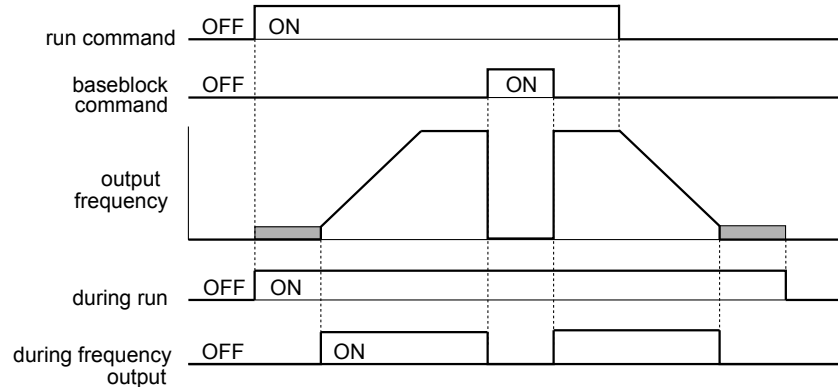

Figure 5.79 During Frequency Output Time Chart

Setting 38: Drive Enable

Reflects the status of a digital input configured as a “Drive enable” input (H1-□□ = 6A). If that digital input closes, then the digital output set for “Drive enable” will also close.

Setting 39: Watt Hour Pulse Output

Outputs a pulse to indicate the watt hours. *Refer to H2-06: Watt Hour Output Unit Selection on page 268* for details.

Setting 3C: LOCAL/REMOTE Status

The output terminal closes while the drive is set for LOCAL and opens when in REMOTE.

Status	Description
Open	REMOTE: The external reference that has been selected (either b1-01 and b1-02 or b1-15 and b1-16) is used as frequency reference and Run command source.
Closed	LOCAL: The digital operator is used as frequency reference and Run command source.

Setting 3D: During Speed Search

The output terminal closes while Speed Search is being performed. *Refer to b3: Speed Search on page 173* for details.

Setting 3E: PID Feedback Low

Output terminal closes when a PID feedback loss (FbL) is detected. The feedback is considered to be lost if it falls below the level set to b5-13 for longer than the time set to b5-14. *Refer to PID Feedback Loss Detection on page 183* for details.

Setting 3F: PID Feedback High

Output terminal closes when a PID feedback loss (FbH) is detected. The feedback is considered to be lost if it rises beyond the level set to b5-36 for longer than the time set to b5-37. *Refer to PID Feedback Loss Detection on page 183* for details.

Setting 4A: During KEB Operation

The output terminal closes while KEB is being performed. *Refer to KEB Ride-Thru Function on page 287* for a KEB function description.

Setting 4B: During Short Circuit Braking

The output terminal closes while Short Circuit Braking is being executed.

Setting 4C: During Fast Stop

The output terminal closes when a Fast Stop is being executed. *Refer to Setting 15, 17: Fast Stop (N.O., N.C.) on page 251.*

Setting 4D: oH Pre-Alarm Time Limit

The output terminal closes when the drive is reducing the speed due to a drive overheat alarm (L8-03 = 4) and the overheat alarm has not disappeared after 10 frequency reduction operation cycles. *Refer to L8-03: Overheat Pre-Alarm Operation Selection on page 307* for a more detailed description.

Setting 4E: Braking Transistor Fault (rr)

The output closes if the internal braking transistor reaches the overheat level.

Setting 4F: Braking Resistor Overheat (rH)

The output closes when the braking resistor exceeds the overheat level. The braking resistor may overheat due to motor regeneration or short deceleration time setting.

Setting 60: Internal Cooling Fan Alarm

The output closes when the drive internal cooling fan has failed.

Setting 61: Rotor Position Detection Complete

Note: PM motor control modes are not available on 600 V class drives, models 5A□□□□.

After the Run command is given, the output terminal signals that the drive has detected the rotor position (PM motors).

Setting 90 to 92: DriveWorksEZ Digital Output 1 to 3

These settings are for output functions used in DriveWorksEZ. Normally there is no need to change these settings.

Setting 100 to 192: Functions 0 to 92 with Inverse Output

These settings have the same function as settings 0 to 92 but with inverse output. Set as 1□□, where the “1” indicates inverse output and the last two digits specify the setting number of the function.

Examples:

- For inverse output of “8: During baseblock”, set 108.
- For inverse output of “4A: During KEB” set 14A.

5.7 H: Terminal Functions

■ H2-06: Watt Hour Output Unit Selection

When one of the multi-function terminals is set to output the number of watt hours (H2-01, H2-02, or H2-03 = 39), parameter H2-06 determines the units for the output signal.

This output function provides a watt hour meter or a PLC input by a 200 ms pulse signal. H2-06 determines the frequency that pulses are issued to keep track of the kWh for the drive.

No.	Parameter Name	Setting Range	Default
H2-06	Watt Hour Output Unit Selection	0: 0.1 kWh units 1: 1 kWh units 2: 10 kWh units 3: 100 kWh units 4: 1000 kWh units	0

- Note:**
1. A negative power output (i.e., regeneration) does not subtract from the total watt hours.
 2. The drive keeps track of the watt hours as long as the control circuit has power. The value is reset when the power supply is shut off.

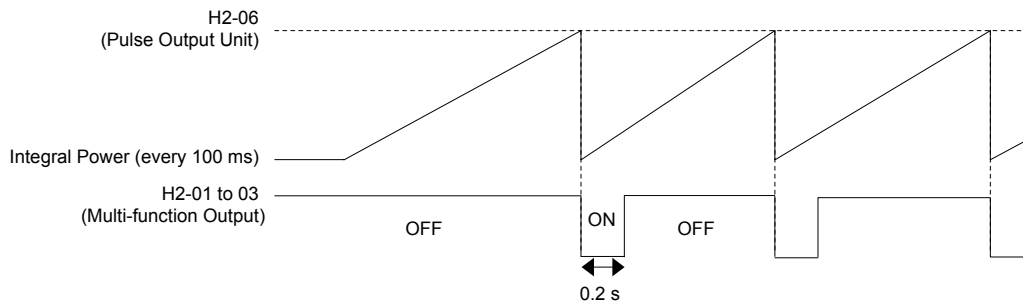

Figure 5.80 Watt Hour Output Example

◆ H3: Multi-Function Analog Inputs

The drive is equipped with three multi-function analog input terminals: A1, A2, and A3. [Refer to Multi-Function Analog Input Terminal Settings on page 271](#) for a listing of the functions that can be set to these terminals.

■ H3-01: Terminal A1 Signal Level Selection

Selects the input signal level for analog input A1.

No.	Name	Setting Range	Default
H3-01	Terminal A1 Signal Level Selection	0 to 1	0

Setting 0: 0 to 10 Vdc

The input level is 0 to 10 Vdc. The minimum input level is limited to 0%, so that a negative input signal due to gain and bias settings will be read as 0%.

Setting 1: -10 to 10 Vdc

The input level is -10 to 10 Vdc. If the resulting voltage is negative after being adjusted by gain and bias settings, then the motor will rotate in reverse.

■ H3-02: Terminal A1 Function Selection

Selects the input signal level for analog input A3. [Refer to Multi-Function Analog Input Terminal Settings on page 271](#) for instructions on adjusting the signal level.

No.	Name	Setting Range	Default
H3-02	Terminal A1 Function Selection	0 to 32	0

■ H3-03, H3-04: Terminal A1 Gain and Bias Settings

Parameter H3-03 sets the level of the selected input value that is equal to 10 Vdc input at terminal A1 (gain).

Parameter H3-04 sets the level of the selected input value that is equal to 0 V input at terminal A1 (bias).

Use both parameters to adjust the characteristics of the analog input signal to terminal A1.

No.	Name	Setting Range	Default
H3-03	Terminal A1 Gain Setting	-999.9 to 999.9%	100.0%
H3-04	Terminal A1 Bias Setting	-999.9 to 999.9%	0.0%

Setting Examples

- Gain H3-03 = 200%, bias H3-04 = 0, terminal A1 as frequency reference input (H3-02 = 0):

A 10 Vdc input is equivalent to a 200% frequency reference and 5 Vdc is equivalent to a 100% frequency reference. Since the drive output is limited by the maximum frequency parameter (E1-04), the frequency reference will be equal to E1-04 above 5 Vdc.

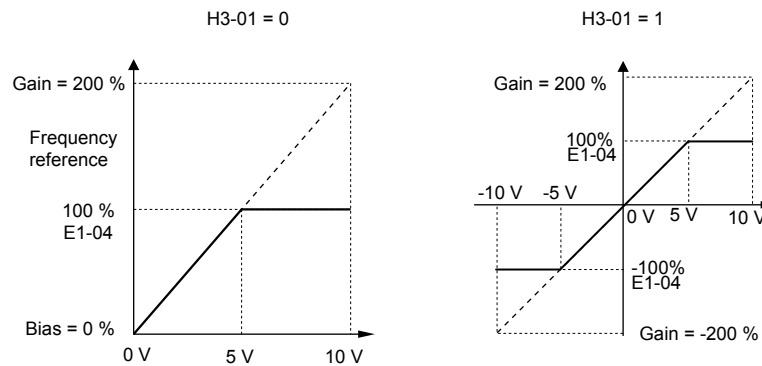

Figure 5.81 Frequency Reference Setting by Analog Input with Increased Gain

- Gain H3-03 = 100%, bias H3-04 = -25%, terminal A1 as frequency reference input:

An input of 0 Vdc will be equivalent to a -25% frequency reference.

When parameter H3-01 = 0, the frequency reference is 0% between 0 and 2 Vdc input.

When parameter H3-01 = 1, the motor will rotate in reverse between -10 and 2 Vdc input.

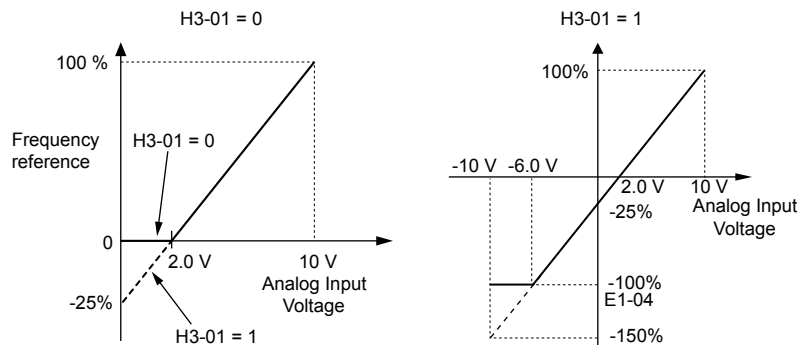

Figure 5.82 Frequency Reference Setting by Analog Input with Negative Bias

■ H3-05: Terminal A3 Signal Level Selection

Determines the function assigned to analog input terminal A3. *Refer to Multi-Function Analog Input Terminal Settings on page 271* for a list of functions and descriptions.

No.	Name	Setting Range	Default
H3-05	Terminal A3 Signal Level Selection	0, 1	0

Setting 0: 0 to 10 Vdc

The input level is 0 to 10 Vdc. See the explanation provided for H3-01. *Refer to Setting 0: 0 to 10 Vdc on page 268.*

5.7 H: Terminal Functions

Setting 1: -10 to 10 Vdc

The input level is -10 to 10 Vdc. See the explanation provided for H3-01. [Refer to Setting 1: -10 to 10 Vdc on page 268.](#)

■ H3-06: Terminal A3 Function Selection

Determines the function assigned to analog input terminal A3. [Refer to Multi-Function Analog Input Terminal Settings on page 271](#) for a list of functions and descriptions.

No.	Name	Setting Range	Default
H3-06	Terminal A3 Function Selection	0 to 31	2

■ H3-07, H3-08: Terminal A3 Gain and Bias Setting

Parameter H3-07 sets the level of the selected input value that is equal to 10 Vdc input at terminal A3 (gain).

Parameter H3-08 sets the level of the selected input value that is equal to 0 V input at terminal A3 (bias).

No.	Name	Setting Range	Default
H3-07	Terminal A3 Gain Setting	-999.9 to 999.9%	100.0%
H3-08	Terminal A3 Bias Setting	-999.9 to 999.9%	0.0%

■ H3-09: Terminal A2 Signal Level Selection

Selects the input signal level for analog input A2. Set DIP switch S1 on the terminal board accordingly for a voltage input or current input.

No.	Name	Setting Range	Default
H3-09	Terminal A2 Signal Level Selection	0 to 3	2

Setting 0: 0 to 10 Vdc

The input level is 0 to 10 Vdc. [Refer to Setting 0: 0 to 10 Vdc on page 268.](#)

Setting 1: -10 to 10 Vdc

The input level is -10 to 10 Vdc. [Refer to Setting 1: -10 to 10 Vdc on page 268.](#)

Setting 2: 4 to 20 mA

The input level is 4 to 20 mA. Negative input values by negative bias or gain settings will be limited to 0%.

Setting 3: 0 to 20 mA

The input level is 0 to 20 mA. Negative input values by negative bias or gain settings will be limited to 0%.

■ H3-10: Terminal A2 Function Selection

Determines the function assigned to analog input terminal A2. [Refer to Multi-Function Analog Input Terminal Settings on page 271](#) for a list of functions and descriptions.

No.	Name	Setting Range	Default
H3-10	Terminal A2 Function Selection	0 to 32	0

■ H3-11, H3-12: Terminal A2 Gain and Bias Setting

Parameter H3-11 sets the level of the input value selected that is equal to 10 Vdc input or 20 mA input to terminal A2.

Parameter H3-12 sets the level of the input value selected that is equal to 0 V, 4 mA or 0 mA input at terminal A2.

Use both parameters to adjust the characteristics of the analog input signal to terminal A2. The setting works in the same way as parameters H3-03 and H3-04 for analog input A1.

No.	Name	Setting Range	Default
H3-11	Terminal A2 Gain Setting	-999.9 to 999.9%	100.0%
H3-12	Terminal A2 Bias Setting	-999.9 to 999.9%	0.0%

■ H3-13: Analog Input Filter Time Constant

Parameter H3-13 sets the time constant for a first order filter that will be applied to the analog inputs.

An analog input filter prevents erratic drive control when using a “noisy” analog reference. Drive operation becomes more stable as the programmed time becomes longer, but it also becomes less responsive to rapidly changing analog signals.

No.	Name	Setting Range	Default
H3-13	Analog Input Filter Time Constant	0.00 to 2.00 s	0.03 s

■ H3-14: Analog Input Terminal Enable Selection

When one of the multi-function digital input parameters is set for “Analog input enable” (H1-□□ = C), the value set to H3-14 determines which analog input terminals are enabled and which terminals are disabled when the input is closed. All analog input terminals will be enabled all of the time if H1-□□ is not set to C.

No.	Name	Setting Range	Default
H3-14	Analog Input Terminal Enable Selection	1 to 7	7

Setting 1: A1 only enabled

Setting 2: A2 only enabled

Setting 3: A1 and A2 only enabled

Setting 4: A3 only enabled

Setting 5: A1 and A3 only enabled

Setting 6: A2 and A3 only enabled

Setting 7: All analog input terminals enabled

■ H3-16 to H3-18: Terminal A1/A2/A3 Offset

Set the offset level of the selected input value to terminals A1, A2, or A3 that is equal to 0 Vdc input. These parameters rarely require adjustment.

No.	Name	Setting Range	Default
H3-16	Terminal A1 Offset	-500 to 500	0
H3-17	Terminal A2 Offset	-500 to 500	0
H3-18	Terminal A3 Offset	-500 to 500	0

■ Multi-Function Analog Input Terminal Settings

See [Table 5.42](#) for information on how H3-02, H3-10, and H3-06 determine functions for terminals A1, A2, and A3.

Note: The scaling of all input functions depends on the gain and bias settings for the analog inputs. Set these to appropriate values when selecting and adjusting analog input functions.

Table 5.42 Multi-Function Analog Input Terminal Settings

Setting	Function	Page	Setting	Function	Page
0	Frequency Bias	272	C	PID Setpoint	273
1	Frequency Gain	272	D	Frequency Bias	273
2	Auxiliary Frequency Reference 1	272	E	Motor Temperature (PTC Input)	273
3	Auxiliary Frequency Reference 2	272	F	Through Mode	273
4	Output Voltage Bias	272	10	Forward Torque Limit	273
5	Accel/Decel Time Gain	272	11	Reverse Torque Limit	
6	DC Injection Braking Current	272	12	Regenerative Torque limit	
7	Torque Detection Level	273	13	Torque Limit Using Torque Reference/Speed Limit	274
8	Stall Prevention Level During Run	273	14	Torque Compensation	274
9	Output Frequency Lower Limit Level	273	15	General Torque Limit	273
B	PID Feedback	273	16	Differential PID Feedback	274

5.7 H: Terminal Functions

Setting	Function	Page
17 <1>	Motor Thermistor (NTC)	274
1F	Through Mode	273
30	DriveWorksEZ Analog Input 1	274
31	DriveWorksEZ Analog Input 2	
32	DriveWorksEZ Analog Input 3	

<1> This function is only available in models 4A0930 to 4A1200.

Setting 0: Frequency Bias

The input value of an analog input set to this function will be added to the analog frequency reference value. When the frequency reference is supplied by a different source other than the analog inputs, this function will have no effect. Use this setting also when only one of the analog inputs is used to supply the frequency reference.

By default, analog inputs A1 and A2 are set for this function. Simultaneously using A1 and A2 increases the frequency reference by the total of all inputs.

Example: If the analog frequency reference from analog input terminal A1 is 50% and a bias of 20% is applied by analog input terminal A2, the resulting frequency reference will be 70% of the maximum output frequency.

Setting 1: Frequency Gain

The input value of an analog input set to this function will be multiplied with the analog frequency reference value.

Example: If the analog frequency reference from analog input terminal A1 is 80% and a gain of 50% is applied from analog input terminal A2, the resulting frequency reference will be 40% of the maximum output frequency.

Setting 2: Auxiliary Reference 1

Sets the auxiliary frequency reference 1 when multi-step speed operation is selected. [Refer to Multi-Step Speed Selection on page 208](#) for details.

Setting 3: Auxiliary Reference 2

Sets the auxiliary frequency reference 2 when multi-step speed operation is selected. [Refer to Multi-Step Speed Selection on page 208](#) for details.

Setting 4: Output Voltage Bias

Voltage bias boosts the output voltage of the V/f curve as a percentage of the maximum output voltage (E1-05). Available only when using V/f Control.

Setting 5: Accel/Decel Time Gain

Adjusts the gain level for the acceleration and deceleration times set to parameters C1-01 through C1-08.

The drive acceleration time is calculated by multiplying the gain level to C1-□□ as follows:

$$C1-□□ \times \text{Accel/decel time gain} = \text{Drive accel/decel time}$$

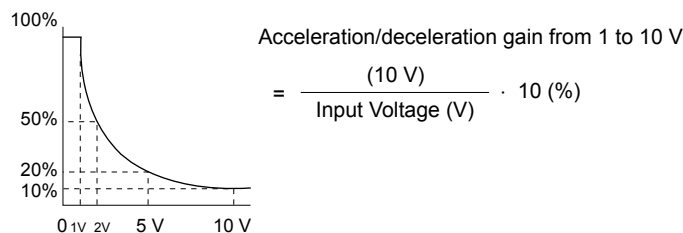

Figure 5.83 Accel/Decel Time Gain with Analog Input Terminal

Setting 6: DC Injection Braking Current

The current level used for DC Injection Braking is set as a percentage of the drive rated current.

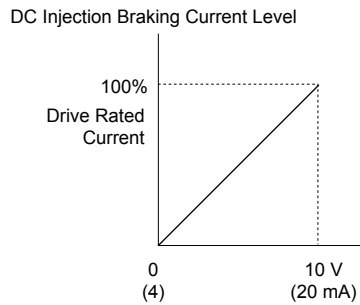

Figure 5.84 DC Injection Braking Current Using an Analog Input Terminal

Setting 7: Torque Detection Level

Using this setting, the overtorque/undertorque detection level for torque detection 1 (L6-01) can be set by an analog input. The analog input replaces the level set to L6-02. An analog input of 100% (10 V or 20 mA) sets a torque detection level equal to 100% drive rated current/motor rated torque. Adjust the analog input gain if higher detection level settings are required. [Refer to L6: Torque Detection on page 302](#) for details on torque detection.

Setting 8: Stall Prevention Level

Allows an analog input signal to adjust the Stall Prevention level. [Figure 5.85](#) shows the setting characteristics. The drive will use the lower value of the Stall Prevention level set to L3-06 or the level coming from the selected analog input terminal.

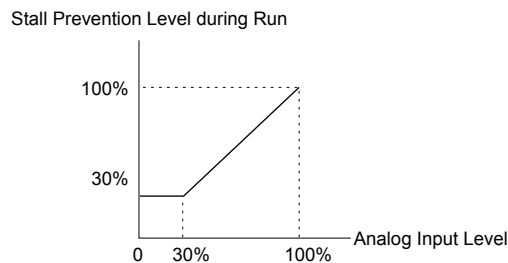

Figure 5.85 Stall Prevention During Run Using an Analog Input Terminal

Setting 9: Output Frequency Lower Limit Level

The user can adjust the lower limit of the output frequency using an analog input signal.

Setting B: PID Feedback

Supplies the PID feedback value. This setting requires PID operation to be enabled in b5-01. [Refer to PID Feedback Input Methods on page 180](#).

Setting C: PID Setpoint

Supplies the PID setpoint value and makes the frequency reference selected in parameter b1-01 no longer the PID setpoint. PID operation to be enabled in b5-01 to use this setting. [Refer to PID Setpoint Input Methods on page 180](#).

Setting D: Frequency Bias

The input value of an analog input set to this function will be added to the frequency reference. This function can be used with any frequency reference source.

Setting E: Motor Temperature

In addition to motor overload fault detection oL1, it is possible to use a Positive Temperature Coefficient (PTC) thermistor for motor insulation protection. [Refer to Motor Protection Using a Positive Temperature Coefficient \(PTC\) Thermistor on page 282](#) for a detailed explanation.

Setting F, 1F: Through Mode

When set to F or 1F, an input does not affect any drive function, but the input level can still be read out by a PLC via a communication option or MEMOBUS/Modbus communications.

Setting 10, 11, 12, 15: Forward, Reverse, Regenerative, General Torque Limit (OLV, CLV, AOLV/PM, CLV/PM)

Note: PM motor control modes are not available on 600 V class drives, models 5A□□□□.

These functions set a torque limit using analog inputs for different operating conditions. [Refer to L7: Torque Limit on page 305](#) for details.

5.7 H: Terminal Functions

Setting 13: Torque Limit Using Torque Reference/Speed Limit

Sets the torque reference (when in Torque Control) or the torque limit (when in Speed Control). *Refer to Setting the Torque Reference, Speed Limit, and Torque Compensation Values on page 217* for details.

Setting 14: Torque Compensation

Sets a torque compensation value when using Torque Control. *Refer to Setting the Torque Reference, Speed Limit, and Torque Compensation Values on page 217* for details.

Setting 16: Differential PID Feedback

If an analog value is set for this function, the PID controller is set for differential feedback. The difference of the PID feedback input value and the differential feedback input value builds the feedback value used to calculate the PID input. *Refer to PID Feedback Input Methods on page 180*.

Setting 17: Motor Thermistor (NTC)

Used as a complement or a substitution for oL1. *Refer to Motor Protection Using an NTC Thermistor Input on page 284* for details.

Setting 30, 31, 32: DriveWorksEZ Analog Inputs 1, 2, and 3

These settings are for DriveWorksEZ functions. Normally there is no need to change or apply these settings.

◆ H4: Multi-Function Analog Outputs

These parameters assign functions to analog output terminals FM and AM for monitoring a specific aspect of drive performance.

■ H4-01, H4-04: Multi-Function Analog Output Terminal FM, AM Monitor Selection

Sets the desired drive monitor parameter U□-□□ to output as an analog value via terminal FM and AM. *Refer to U: Monitor Parameters on page 331* for a list of all monitors. The “Analog Output Level” column indicates whether a monitor can be used for analog output.

Example: Enter “103” for U1-03.

No.	Name	Setting Range	Default
H4-01	Multi-Function Analog Output Terminal FM Monitor Selection	000 to 999	102
H4-04	Multi-Function Analog Output Terminal AM Monitor Selection	000 to 999	103

A setting of 031 or 000 applies no drive monitor to the analog output. With this setting, terminal functions as well as FM and AM output levels can be set by a PLC via a communication option or MEMOBUS/Modbus (through mode).

■ H4-02, H4-03: Multi-Function Analog Output Terminal FM Gain and Bias H4-05, H4-06: Multi-Function Analog Output Terminal AM Gain and Bias

Parameters H4-02 and H4-05 set the terminal FM and AM output signal level when the value of the selected monitor is at 100%. Parameters H4-03 and H4-06 set the terminal FM and AM output signal level when the value of the selected monitor is at 0%. Both are set as a percentage, where 100% equals 10 Vdc or 20 mA analog output and 0% equals 0 V or 4 mA. The output voltage of both terminals is limited to +/-10 Vdc.

The output signal range can be selected between 0 to +10 Vdc or -10 to +10 Vdc, or 4 to 20 mA using parameter H4-07 and H4-08. *Figure 5.86* illustrates how gain and bias settings work.

No.	Name	Setting Range	Default
H4-02	Multi-Function Analog Output Terminal FM Gain	-999.9 to 999.9%	100.0%
H4-03	Multi-Function Analog Output Terminal FM Bias	-999.9 to 999.9%	0.0%
H4-05	Multi-Function Analog Output Terminal AM Gain	-999.9 to 999.9%	50.0%
H4-06	Multi-Function Analog Output Terminal AM Bias	-999.9 to 999.9%	0.0%

Using Gain and Bias to Adjust Output Signal Level

The output signal is adjustable while the drive is stopped.

Terminal FM

1. View the value set to H4-02 (Terminal FM Monitor Gain) on the digital operator. A voltage equal to 100% of the parameter being set in H4-01 will be output from terminal FM.
2. Adjust H4-02 viewing the monitor connected to the terminal FM.

3. View the value set to H4-03 on the digital operator; terminal FM will output a voltage equal to 0% of the parameter being set in H4-01.
4. Adjust H4-03 viewing the output signal on the terminal FM.

Terminal AM

1. View the value set to H4-05 (Terminal AM Monitor Gain) on the digital operator. A voltage equal to 100% of the parameter being set in H4-04 will be output from terminal AM.
2. Adjust H4-05 viewing the monitor connected to the terminal AM.
3. View the value set to H4-06 on the digital operator; terminal AM will output a voltage equal to 0% of the parameter being set in H4-04.
4. Adjust H4-06 viewing the output signal on the terminal AM.

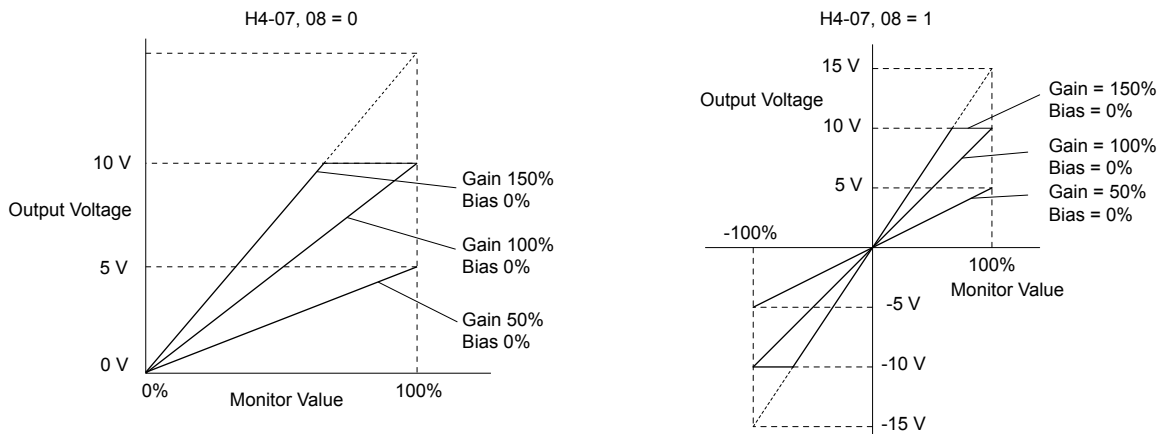

Figure 5.86 Analog Output Gain and Bias Setting Example 1 and 2

Set H4-03 to 30% for an output signal of 3 V at terminal FM when the monitored value is at 0%.

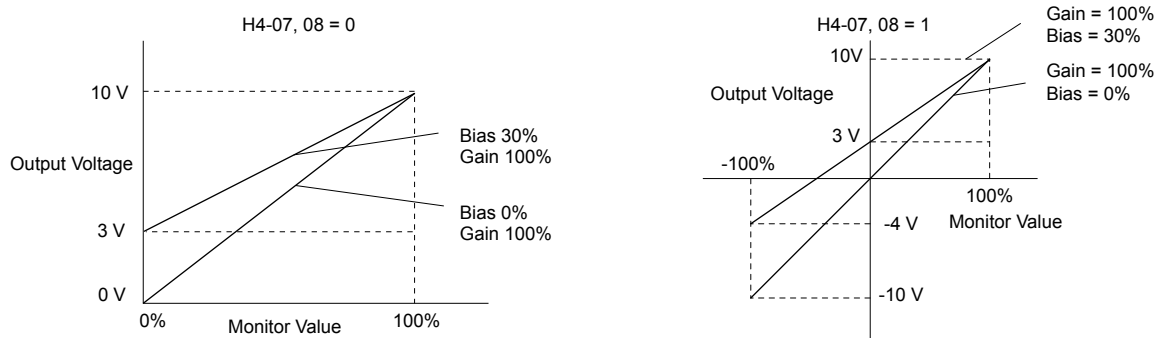

Figure 5.87 Analog Output Gain and Bias Setting Example 3

■ H4-07, H4-08: Multi-Function Analog Output Terminal FM, AM Signal Level Selection

Sets the voltage output level of U parameter (monitor parameter) data to terminal FM and terminal AM using parameters H4-07 and H4-08.

Set jumper S5 on the terminal board accordingly when changing these parameters. *Refer to Terminal AM/FM Signal Selection on page 107* for details on setting S5.

No.	Name	Setting Range	Default
H4-07	Multi-Function Analog Output Terminal FM Signal Level Selection	0 to 2	0
H4-08	Multi-Function Analog Output Terminal AM Signal Level Selection	0 to 2	0

5.7 H: Terminal Functions

Setting 0: 0 to 10 V

Setting 1: -10 V to 10 V

Setting 2: 4 to 20 mA

◆ H5: MEMOBUS/Modbus Serial Communication

Serial communication is possible in the drive using the built-in RS-422/485 port (terminals R+, R-, S+, S-) and programmable logic controllers (PLCs) or similar devices running the MEMOBUS/Modbus protocol.

The H5-□□ parameters set the drive for MEMOBUS/Modbus Communications. *Refer to MEMOBUS/Modbus Serial Communication on page 616* for detailed descriptions of the H5-□□ parameters.

◆ H6: Pulse Train Input/Output

A one-track pulse train signal with a maximum frequency of 32 kHz can be input to the drive at terminal RP. This pulse train signal can be used as the frequency reference, for PID functions, or as the speed feedback signal in V/f Control.

The pulse output monitor terminal MP can output drive monitor values as a pulse train signal with a maximum frequency of 32 kHz in sinking or sourcing mode. *Refer to Using the Pulse Train Output on page 105* for details.

Use parameters H6-□□ to set the scale and other aspects of the pulse input terminal RP and pulse output terminal MP.

■ H6-01: Pulse Train Input Terminal RP Function Selection

Selects the function of pulse train input terminal RP.

No.	Name	Setting Range	Default
H6-01	Pulse Train Input Terminal RP Function Selection	0 to 3	0

Setting 0: Frequency reference

If the pulse input is set for this function and the frequency reference source is set to pulse input (b1-01, b1-15 = 4), the drive reads the frequency value from terminal RP.

Setting 1: PID feedback value

Using this setting, the feedback value for PID control can be supplied as a pulse signal at terminal RP. *Refer to b5: PID Control on page 179* for details on PID control.

Setting 2: PID setpoint value

Using this setting, the setpoint value for PID control can be supplied as a pulse signal at terminal RP. *Refer to b5: PID Control on page 179* for details on PID control.

Setting 3: Speed feedback (V/f Control with Simple Speed Feedback)

This setting can be used in V/f control to increase the speed control precision by using a motor speed feedback signal. The drive reads the speed feedback from terminal RP, compares it to the frequency reference and compensates the motor slip using a speed regulator (ASR, set up in the C5-□□ parameters) like shown in *Figure 5.88*. Because input terminal RP is incapable of detecting motor direction, a separate way of determining motor direction still needs to be set up:

1. Using a Digital Input

If a digital input programmed for “Forward/reverse detection” (H1-□□ = 7E) is closed, the drive assumes reverse rotation. If open, then the drive assumes that the motor is rotating forwards.

2. Using the Frequency Reference Direction

If no digital input is set to “Forward/reverse detection” (H1-□□ = 7E), the drive uses the direction of the frequency reference as the direction for the speed feedback detected at the pulse input.

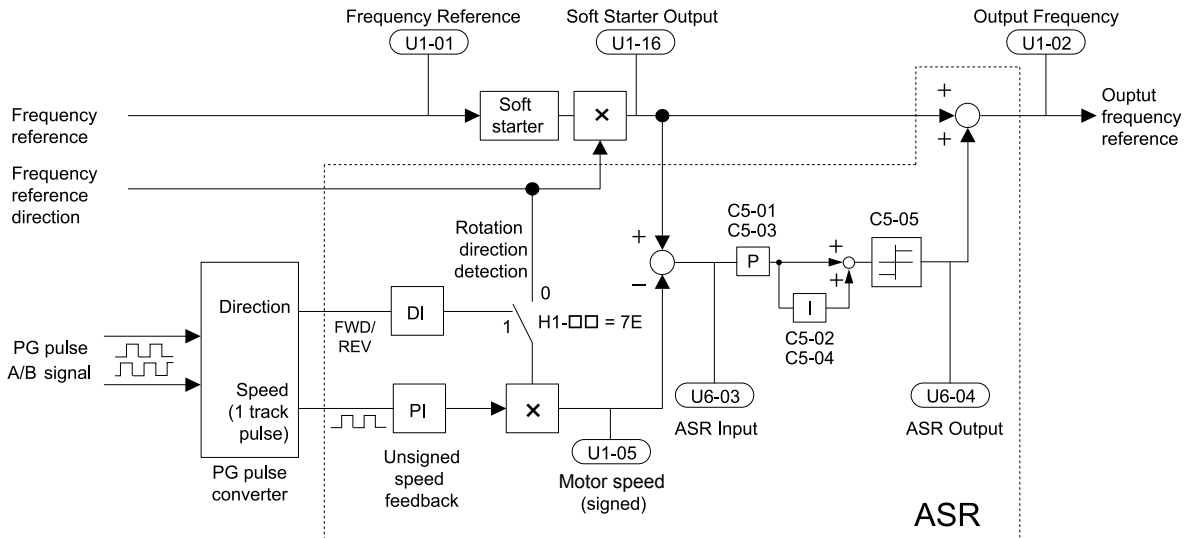

Figure 5.88 Speed Control with ASR in V/f with Simple Speed Feedback

Enabling V/f Control with Simple Speed Feedback:

1. Set the drive to V/f Control (A1-02 = 0).
2. Connect the motor speed pulse signal to the pulse input RP, set H6-01 = 3, and set the pulse signal frequency that is equal to the maximum speed to H6-02 (pulse input scaling). Make sure the pulse input bias (H6-04) is 0% and the gain (H6-03) is 100%.
3. Decide on the signal used for detecting the direction. Set H1-□□ = 7E if using a digital input.
4. Use the ASR gain and integral time parameters described in [C5: Automatic Speed Regulator \(ASR\)](#) on page 200 for adjusting the responsiveness.

- Note:**
1. C5 parameters will appear when using V/f Control (A1-02 = 0) and when the pulse input RP function is set for simple PG feedback in V/f Control (H6-01 = 3).
 2. If running two motors from the same drive, V/f Control with simple PG feedback can be used for motor 1 only.

■ H6-02: Pulse Train Input Scaling

Sets the pulse signal frequency that is equal to 100% of the input value selected in parameter H6-01.

No.	Name	Setting Range	Default
H6-02	Pulse Train Input Scaling	100 to 32000 Hz	1440 Hz

■ H6-03: Pulse Train Input Gain

Sets the level of the input value selected in H6-01 when a pulse train signal with the frequency set in H6-02 is input to terminal RP.

No.	Name	Setting Range	Default
H6-03	Pulse Train Input Gain	0.0 to 1000.0%	100.0%

■ H6-04: Pulse Train Input Bias

Sets the level of the input value selected in H6-01 when no signal (0 Hz) is input to terminal RP.

No.	Name	Setting Range	Default
H6-04	Pulse Train Input Bias	-100.0 to 100.0%	0.0%

■ H6-05: Pulse Train Input Filter Time

Sets the pulse train input filter time constant in seconds.

No.	Name	Setting Range	Default
H6-05	Pulse Train Input Filter Time	0.00 to 2.00 s	0.10 s

5.7 H: Terminal Functions

■ H6-06: Pulse Train Monitor Selection

Selects the monitor to output as a pulse train signal via terminal MP. Enter the three digits in U□-□□ to indicate which monitor to output. *Refer to U: Monitor Parameters on page 331* for a complete list of monitors. Monitors that can be selected by H6-06 appear in the table below.

No.	Name	Setting Range	Default
H6-06	Pulse Train Monitor Selection	000 <I>, 031 <I>, 101, 102, 105, 116, 501, 502, 801 to 809	102

<I> Set "000" when the terminal is not used or when using the terminal in the through mode.

■ H6-07: Pulse Train Monitor Scaling

Sets the output frequency at terminal MP when the specified monitor item is at 100%. Set H6-06 to 102 and H6-07 to 0 to make the pulse train monitor output synchronous to the output frequency.

No.	Name	Setting Range	Default
H6-07	Pulse Train Monitor Scaling	0 to 32000 Hz	1440 Hz

■ H6-08: Pulse Train Input Minimum Frequency

Sets the minimum output frequency detected by the pulse train input. Increasing this setting reduces the time the drive needs to react to changes in the input signal.

- The pulse input value becomes 0 when the pulse input frequency falls below this level.
- Enabled when H6-01 = 0, 1, or 2.
- When simple speed feedback in V/f Control is set as the function for terminal RP (H6-01 = 3), the minimum frequency becomes the detection time for PG disconnect (F1-14).

No.	Name	Setting Range	Default
H6-08	Pulse Train Input Minimum Frequency	0.1 to 1000.0 Hz	0.5 Hz

5.8 L: Protection Functions

◆ L1: Motor Protection

■ L1-01: Motor Overload Protection Selection

The drive has an electronic overload protection function that estimates the motor overload level based on output current, output frequency, thermal motor characteristics, and time. When the drive detects a motor overload an oL1 fault is triggered and the drive output shuts off.

L1-01 sets the overload protection function characteristics according to the motor being used.

No.	Name	Setting Range	Default
L1-01	Motor Overload Protection Selection	0 to 6	Determined by A1-02

- Note:**
- When the motor protection function is enabled (L1-01 ≠ 0), an oL1 alarm can be output through one of the multi-function outputs by setting H2-01 to 1F. The output closes when the motor overload level reaches 90% of the oL1 detection level.
 - Set L1-01 to a value between 1 and 6 when running a single motor from the drive to select a method to protect the motor from overheat. An external thermal relay is not necessary.

Setting 0: Disabled (motor overload protection is not provided)

Use this setting if no motor overheat protection is desired or if multiple motors are connected to a single drive. If multiple motors are connected to a single drive, install a thermal relay for each motor as shown in [Figure 5.89](#).

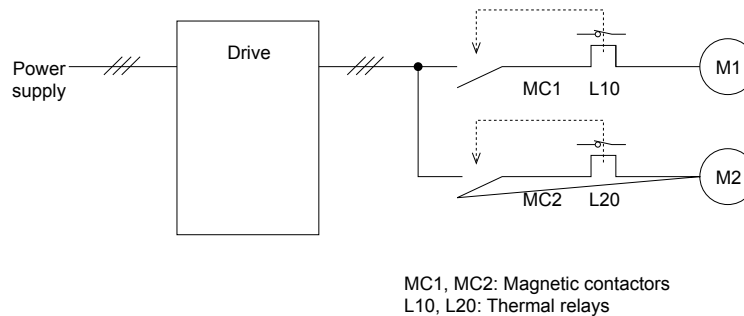

Figure 5.89 Example of Protection Circuit Design for Multiple Motors

NOTICE: Thermal protection cannot be provided when running multi-motors simultaneously with the same drive, or when using motors with a relatively high current rating compared to other standard motors (such as a submersible motor). Failure to comply could result in motor damage. Disable the electronic overload protection of the drive (L1-01 = "0: Disabled") and protect each motor with individual motor thermal overloads.

Note: Close MC1 and MC2 before operating the drive. MC1 and MC2 cannot be switched off during run.

Setting 1: General-purpose motor (standard self-cooled)

Because the motor is self-cooled, the overload tolerance drops when the motor speed is lowered. The drive appropriately adjusts the electrothermal trigger point according to the motor overload characteristics, protecting the motor from overheat throughout the entire speed range.

Overload Tolerance	Cooling Ability	Overload Characteristics
<p>Rated Speed=100% Speed 60 s A: Max. speed for 200LJ and above B: Max. speed for 160MJ to 180 LJ C: Max. speed for 132MJ and below</p>	<p>Motor designed to operate from line power. Motor cooling is most effective when running at rated base frequency (check the motor nameplate or specifications).</p>	<p>Continuous operation at less than line power frequency with 100% load can trigger motor overload protection (oL1). A fault is output and the motor will coast to stop.</p>

5.8 L: Protection Functions

Setting 2: Drive dedicated motor (speed range for constant torque: 1:10)

Use this setting when operating a drive duty motor that allows constant torque in a speed range of 1:10. The drive will allow the motor to run with 100% load from 10% up to 100% speed. Running at slower speeds with full load can trigger an overload fault.

Overload Tolerance	Cooling Ability	Overload Characteristics
	<p>Motor is designed to effectively cool itself even at low speeds.</p>	<p>Continuous operation with 100% load from 6 Hz to E1-06, Motor Base Frequency.</p>

Setting 3: Vector motor (speed range for constant torque: 1:100)

Use this setting when operating a drive-dedicated motor that allows constant torque in a speed range of 1:100. This motor type is allowed to run with 100% load from 1% up to 100% speed. Running slower speeds with full load can trigger an overload fault.

Overload Tolerance	Cooling Ability	Overload Characteristics
	<p>Motor is designed to effectively cool itself at speeds near 0.6 Hz.</p>	<p>Continuous operation with 100% load from 0.6 Hz to E1-06, Motor Base Frequency. Continuous operation below 0.6 Hz may cause an oL1 or oL2 fault.</p>

Setting 4: PM derated torque motor

Note: PM motor control modes are not available on 600 V class drives, models 5A□□□□.

Use this setting when operating a PM motor. PM motors for derated torque have a self-cooling design and the overload tolerance drops as the motor slows. Electronic thermal overload is triggered in accordance with the motor overload characteristics, providing overheat protection across the entire speed range.

Overload Tolerance	Cooling Ability	Overload Characteristics
	<p>Motor is designed to produce 100% torque at base speed. Built with effective cooling capabilities.</p>	<p>Reaching 100% when operating at below the base frequency causes a motor overload fault (oL1). The drive fault output closes and the motor coasts to stop.</p>

Setting 5: Constant torque PM motors (constant torque range of 1:500)

Note: PM motor control modes are not available on 600 V class drives, models 5A□□□□.

Sets necessary protection characteristics when driving a PM with constant torque. These motors allow for a speed control from 0.2% to 100% when operating with 100% load. Slower speeds with 100% load will trigger overload.

Overload Tolerance	Cooling Ability	Overload Characteristics
	<p>Motor is designed to effectively cool itself at speeds near 0.2% of base speed.</p>	<p>Continuous operation with 100% load from 0.2% to 100% of base speed.</p>

Setting 6: General-purpose motor

Note: General-purpose motors are designed with a base speed that operates at line frequency (50/60 Hz depending on geographic region).

Because the motor is self-cooled, the overload tolerance drops when the motor speed is lowered. The drive appropriately adjusts the electrothermal trigger point according to the motor overload characteristics and protects the motor from overheating throughout the entire speed range.

Overload Tolerance	Cooling Ability	Overload Characteristics
	<p>Motor designed to operate from line power. Motor cooling is most effective when running at rated base frequency (check the motor nameplate or specifications)</p>	<p>Continuous operation at less than line power frequency with 100% load can trigger motor overload protection (oL1). A fault is output and the motor will coast to stop.</p>

■ L1-02: Motor Overload Protection Time

Sets the detection time of motor overheat due to overload. This setting rarely requires adjustment, but should correlate with the motor overload tolerance protection time for performing a hot start.

No.	Name	Setting Range	Default
L1-02	Motor Overload Protection Time	0.1 to 5.0 minutes	1.0 minutes

Defaulted to operate with an allowance of 150% overload operation for one minute in a hot start.

Figure 5.90 illustrates an example of the electrothermal protection operation time using a general-purpose motor operating at the value of E1-06, Motor Base Speed, with L1-02 set to one minute.

During normal operation, motor overload protection operates in the area between a cold start and a hot start.

- Cold start: Motor protection operation time in response to an overload situation that was suddenly reached when starting a stationary motor.
- Hot start: Motor protection operation time in response to an overload situation that occurred during sustained operation at rated current.

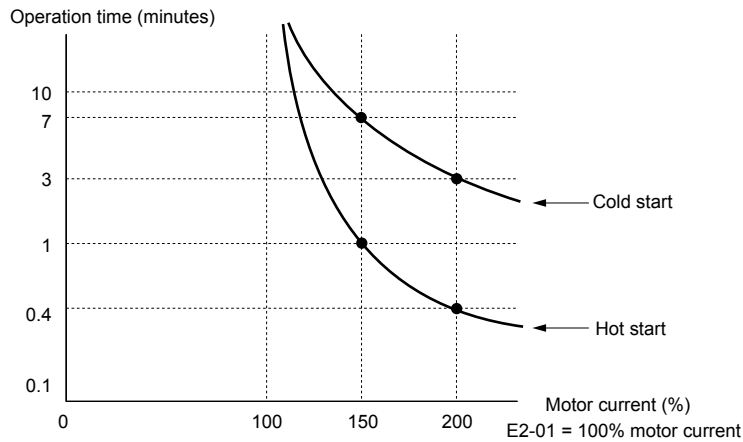

Figure 5.90 Motor Protection Operation Time

■ Motor Protection Using a Positive Temperature Coefficient (PTC) Thermistor

Connect a motor PTC can to an analog input of the drive for motor overheating protection.

The motor overheating alarm level triggers an oH3 alarm and the drive continues the operation selected in L1-03. The overheating fault level triggers an oH4 fault, outputs a fault signal, and the drive stops the motor using the stop method selected in L1-04.

Connect the PTC between terminals AC and A3 and set jumper S4 on the terminal board to "PTC" as shown in [Figure 5.91](#). Set H3-05 to 0 and H3-06 to E.

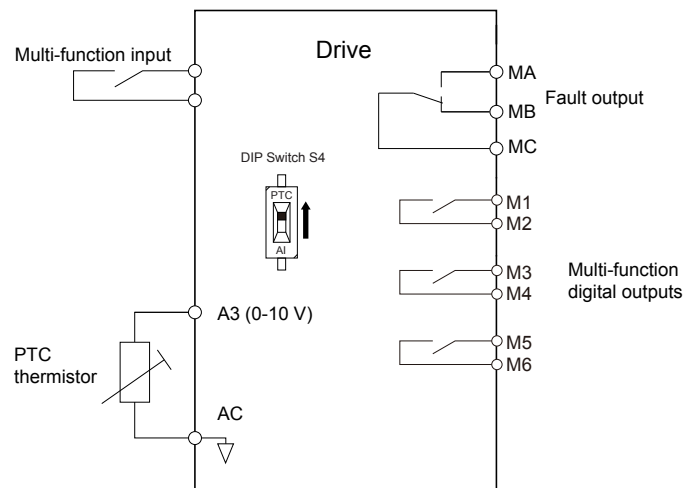

Figure 5.91 Connection of a Motor PTC

The PTC must exhibit the characteristics shown in [Figure 5.92](#) in one motor phase. The motor overload protection of the drive expects 3 of these PTCs to be connected in a series.

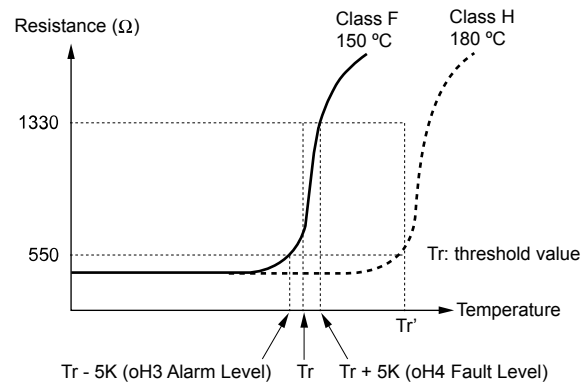

Figure 5.92 Motor PTC Characteristics

Set up overheat detection using a PTC using parameters L1-03, L1-04, and L1-05 as explained in the following sections.

■ L1-03: Motor Overheat Alarm Operation Selection (PTC input)

Sets the drive operation when the PTC input signal reaches the motor overheat alarm level (oH3).

No.	Name	Setting Range	Default
L1-03	Motor Overheat Alarm Operation Selection (PTC input)	0 to 3	3

Setting 0: Ramp to stop

The drive stops the motor using the deceleration time 1 set in parameter C1-02.

Setting 1: Coast to stop

The drive output is switched off and the motor coasts to stop.

Setting 2: Fast Stop

The drive stops the motor using the Fast Stop time set in parameter C1-09.

Setting 3: Alarm only

The operation is continued and an oH3 alarm is displayed on the digital operator.

■ L1-04: Motor Overheat Fault Operation Selection (PTC input)

Sets the drive operation when the PTC input signal reaches the motor overheat fault level (oH4).

No.	Name	Setting Range	Default
L1-04	Motor Overheat Fault Operation Selection (PTC input)	0 to 2	1

Setting 0: Ramp to Stop

The drive stops the motor using the deceleration time 1 set in parameter C1-02.

Setting 1: Coast to Stop

The drive output is switched off and the motor coasts to stop.

Setting 2: Fast Stop

The drive stops the motor using the Fast Stop time set in parameter C1-09.

■ L1-05: Motor Temperature Input Filter Time (PTC input)

Sets a filter on the PTC input signal to prevent erroneous detection of a motor overheat fault.

No.	Name	Setting Range	Default
L1-05	Motor Temperature Input Filter Time (PTC input)	0.00 to 10.00 s	0.20 s

5.8 L: Protection Functions

■ L1-13: Continuous Electrothermal Operation Selection

Determines whether to hold the current value of the electrothermal motor protection (L1-01) when the power supply is interrupted.

No.	Name	Setting Range	Default
L1-13	Continuous Electrothermal Operation Selection	0, 1	1

Setting 0: Disabled

Setting 1: Enabled

■ Motor Protection Using an NTC Thermistor Input

Motor protection is possible for models 4A0930 and 4A1200 by connecting the NTC thermistor input in the motor windings to one of the drive analog input terminals.

This enables the drive to provide torque compensation in response to changes in motor temperature and protect the motor from overheating.

If the NTC input signal using the drive multi-function analog input terminal exceeds the overheat alarm level set to L1-16 (or L1-18 for motor 2), then "oH5" will flash on the digital operator screen. The drive will respond to the alarm according to the setting of L1-20 (default setting is to continue operation when an oH5 alarm occurs).

Figure 5.93 shows a circuit using the NTC thermistor and the terminal resistance values. Set DIP switch S1 on the drive to "V" for voltage input when wiring the NTC thermistor input to terminal A2 on the drive.

Note: This example assumes that H3-10 = 17, H3-09 = 0, and that DIP switch S1 has been set for voltage input.

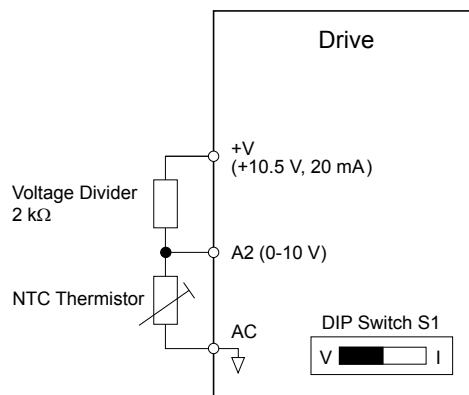

Figure 5.93 Motor Protection Circuit Using NTC Input

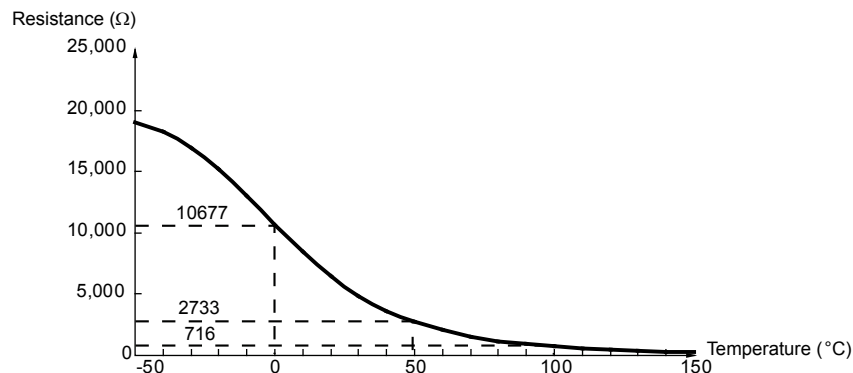

Figure 5.94 Temperature and Resistance of NTC Thermistor

L1-15 to L1-20 can determine the overheat protection settings using the NTC thermistor input. Parameter descriptions are listed below.

■ L1-15: Motor 1 Thermistor Selection (NTC)

Note: This parameter is only available in models 4A0930 and 4A1200.

No.	Name	Setting Range	Default
L1-15	Motor 1 Thermistor Selection (NTC)	0 to 2	0

Setting 0: Disabled

Setting 1: Thermistor input by Analog input

Setting 2: Thermistor input by special Thermistor input

■ L1-16: Motor 1 Overheat Temperature

Note: This parameter is only available in models 4A0930 and 4A1200.

Sets the temperature that will trigger an overheat fault (oH5) for motor 1.

No.	Name	Setting Range	Default
L1-16	Motor 1 Overheat Temperature	50 to 200 °C	120 °C

■ L1-17: Motor 2 Thermistor Selection (NTC)

Note: This parameter is only available in models 4A0930 and 4A1200.

No.	Name	Setting Range	Default
L1-17	Motor 2 Thermistor Selection (NTC)	0 to 2	0

Setting 0: Disabled

Setting 1: Thermistor input by Analog input

Setting 2: Thermistor input by special Thermistor input

■ L1-18: Motor 2 Overheat Temperature

Note: This parameter is only available in models 4A0930 and 4A1200.

Sets the temperature that will trigger an overheat fault (oH5) for motor 2.

No.	Name	Setting Range	Default
L1-18	Motor 2 Overheat Temperature	50 to 200 °C	120 °C

■ L1-19: Operation Time at Thermistor Disconnect (NTC)

Note: This parameter is only available in models 4A0930 and 4A1200.

Determines drive operation when a thermistor disconnect fault (THo) occurs.

No.	Name	Setting Range	Default
L1-19	Operation Time at Thermistor Disconnect (NTC)	0 to 3	3

Setting 0: Ramp to stop

The drive stops the motor using the deceleration time set in parameter C1-02.

Setting 1: Coast to stop

The drive output is switched off and the motor coasts to a stop.

Setting 2: Fast stop

The drive stops the motor using the Fast stop time set in parameter C1-09.

Setting 3: Alarm only

The operation is continued and a THo alarm is displayed on the digital operator.

■ L1-20: Operation at Motor Overheat

Note: This parameter is only available in models 4A0930 and 4A1200.

Determines drive operation when a motor overheat fault (oH5) occurs.

5.8 L: Protection Functions

No.	Name	Setting Range	Default
L1-20	Operation at Motor Overheat	0 to 3	1

Setting 0: Ramp to stop

The drive stops the motor using the deceleration time set in parameter C1-02.

Setting 1: Coast to stop

The drive output is switched off and the motor coasts to a stop.

Setting 2: Fast stop

The drive stops the motor using the Fast stop time set in parameter C1-09.

Setting 3: Alarm only

The operation is continued and an oH5 alarm is displayed on the digital operator.

◆ L2: Momentary Power Loss Ride-Thru

■ L2-01: Momentary Power Loss Operation Selection

When a momentary power loss occurs (DC bus voltage falls below the level set in L2-05), the drive can automatically return to the operation it was performing prior to the power loss based on certain conditions.

No.	Name	Setting Range	Default
L2-01	Momentary Power Loss Operation Selection	0 to 5	0

Setting 0: Disabled (default)

If power is not restored within 15 ms, a Uv1 fault will result and the motor coasts to stop.

Setting 1: Recover within L2-02

When a momentary power loss occurs, the drive output will be shut off. If the power returns within the time set to parameter L2-02, the drive will perform Speed Search and attempt to resume operation. If power is not restored within this time (i.e., DC bus voltage level remains below Uv1 detection level L2-05), then a Uv1 fault is triggered and the drive will stop.

Setting 2: Recover as long as CPU has power

When a momentary power loss occurs, the drive output will be shut off. If the power returns and the drive control circuit has power, the drive will attempt to perform Speed Search and resume the operation. This will not trigger a Uv1 fault.

Setting 3: Kinetic Energy Backup (KEB) Ride-Thru operation within L2-02

The drive decelerates using regenerative energy from the motor until the time set in L2-02 has expired. It then tries to accelerate back to the frequency reference. If the power does not return within the time set to L2-02, it will trigger a Uv1 fault and the drive output will shut off. The type of KEB operation is determined by the L2-29 setting.

Setting 4: KEB Ride-Thru as long as CPU has power

The drive decelerates using regenerative energy from the motor until the power returns and then restarts. If the motor comes to a stop before the power returns, the drive loses control power and the drive output shuts off. A Uv1 fault is not triggered. The type of KEB operation is determined by the L2-29 setting.

Setting 5: Ramp to stop with KEB deceleration

The drive ramps to stop using the regenerative energy from the motor. Even if the power is restored, the drive will continue to decelerate until the motor comes to a complete stop. The type of KEB operation is determined by the L2-29 setting. If an input terminal set for KEB 1 (H1-□□ = 65, 66) is triggered while the drive is decelerating, it will accelerate back up to speed when the input is released.

Notes on Settings 1 through 5

- “Uv” will flash on the operator while the drive is attempting to recover from a momentary power loss. A fault signal is not output at this time.
- A Momentary Power Loss Unit is available to allow for a longer momentary power loss ride through time in models 2A0004 to 2A0056 and 4A0002 to 4A0031. This option makes it possible to continue running the drive after up to two seconds of power loss.
- When using a magnetic contactor between the motor and the drive, keep the magnetic contactor closed as long as the drive performs KEB operation or attempts to restart with Speed Search.
- Keep the Run command active during KEB operation or the drive cannot accelerate back to the frequency reference when the power returns.

- When L2-01 is set to 3, 4, or 5, KEB Ride-Thru will be executed as specified in L2-29.

■ KEB Ride-Thru Function

When the drive detects a power loss, KEB Ride-Thru decelerates the motor and uses regenerative energy to keep the main circuit operating. Despite power loss, the drive output is not interrupted.

Choose between Single Drive KEB Ride-Thru 1 and 2 (L2-29 = 0 or 1 for applications driven by a single drive.

Choose between System KEB Ride-Thru 1 and 2, (L2-29 = 2 or 3) for applications where multiple drives have to perform KEB operation while keeping a certain speed ratio.

Single Drive KEB Ride-Thru 1 (L2-29 = 0)

After KEB Ride-Thru begins, the drive uses regenerative energy from the motor to keep the DC bus voltage at the level set to L2-11 while adjusting the rate of deceleration based on the time set to L2-06. The user must set L2-06 properly to prevent Uv1 and ov faults.

Note: Shorten the KEB deceleration time (L2-06) if undervoltage (Uv1) occurs in the DC bus. Increase the KEB deceleration time if overvoltage (ov) occurs.

Single Drive KEB Ride-Thru 2 (L2-29 = 1)

The drive uses information about the inertia of the connected machinery to determine the deceleration rate necessary to keep the DC bus voltage at the level set in parameter L2-11. The resulting deceleration time is calculated based on the system inertia and cannot be adjusted.

System KEB Ride-Thru 1 (L2-29 = 2)

The drive decelerates at the KEB deceleration time set to L2-06. L2-06 is the time required to decelerate from the current frequency reference to 0. Using this setting, multiple drives can decelerate while keeping the speed ratio constant between those drives. This function requires a braking resistor and disregards the voltage level in the DC bus.

System KEB Ride-Thru 2 (L2-29 = 3)

The drive decelerates based on the KEB deceleration time set to L2-06 while monitoring the DC bus voltage. If the voltage level rises, the drive briefly holds the frequency before continuing to decelerate.

■ KEB Ride-Thru Start

KEB operation is triggered independently of the selected KEB operation mode. When the KEB function is selected as the function to be executed when power loss operation occurs (L2-01 = 3, 4, or 5), then KEB Ride-Thru will be activated if one of the following conditions becomes true:

- A digital input programmed for H1-□□ = 65 or 66 is activated. This will start KEB operation using the mode selected in parameter L2-29.
- A digital input programmed for H1-□□ = 7A or 7B is activated. This will automatically select Single KEB Ride-Thru 2, disregarding the setting of L2-29.
- The DC bus voltage fell below the level specified in L2-05. The KEB operation will start as specified in L2-29.

Note: Attempting to simultaneously assign KEB Ride-Thru 1 and 2 to input terminals will trigger an oPE3 error.

When using a digital input to trigger KEB operation and the device controlling the input acts relatively slow, set a minimum KEB operation time in parameter L2-10. In the example below, the DC bus voltage triggers KEB operation and a digital input triggers the Hold command.

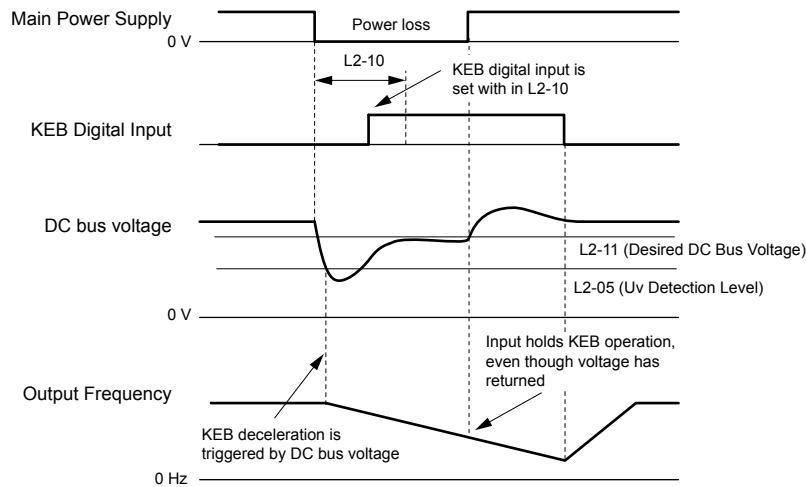

Figure 5.95 KEB Operation Using a KEB Input

■ KEB Ride-Through End Detection

The KEB function end detection depends on the setting of parameter L2-01 and whether a digital input programmed for KEB (H1-□□ = 65, 66, 7A, 7B) is used.

KEB Ride-Through Operation in L2-02, Input Terminals Not Used

Here, L2-01 = 3 and the input terminals have not been set for KEB Ride-Through (H1-□□ does not equal 65, 66, 7A, 7B). After decelerating for the time set in parameter L2-02, the drive ends KEB operation and attempts to accelerate back to the frequency reference. A Uv1 fault occurs and the drive output shuts off if the power does not return within the time set to L2-02.

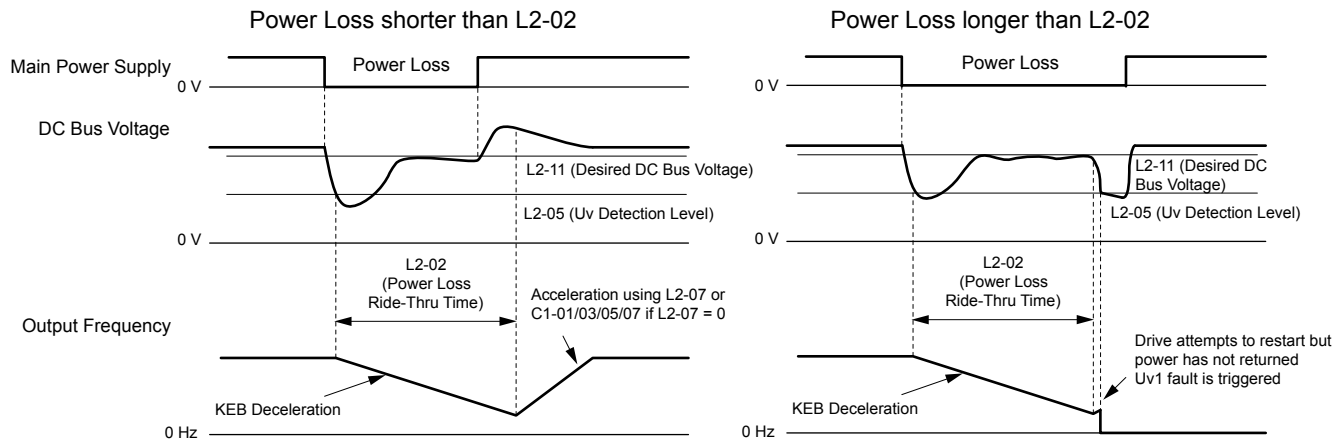

Figure 5.96 KEB Operation Using L2-02, Without KEB Input

KEB Ride-Through Operation Within L2-02, Input Terminals Used

Here, L2-01 = 3 and an input terminal is set to issue KEB Ride-Through (H1-□□ = 65, 66, 7A, 7B). After decelerating for the time set in parameter L2-02, the drive checks the DC bus voltage and the status of the digital input. If the DC bus voltage is still below the level set in L2-11 or if the KEB digital input is still active, KEB deceleration continues. If the voltage level has risen above the value set to L2-11, then normal operation is resumed.

Note: If L2-10 is set to a longer time than L2-02, the drive checks the DC bus voltage level and the status of the terminal assigned to KEB Ride-Through after the time set to L2-02 passes. The drive will then try to restart.

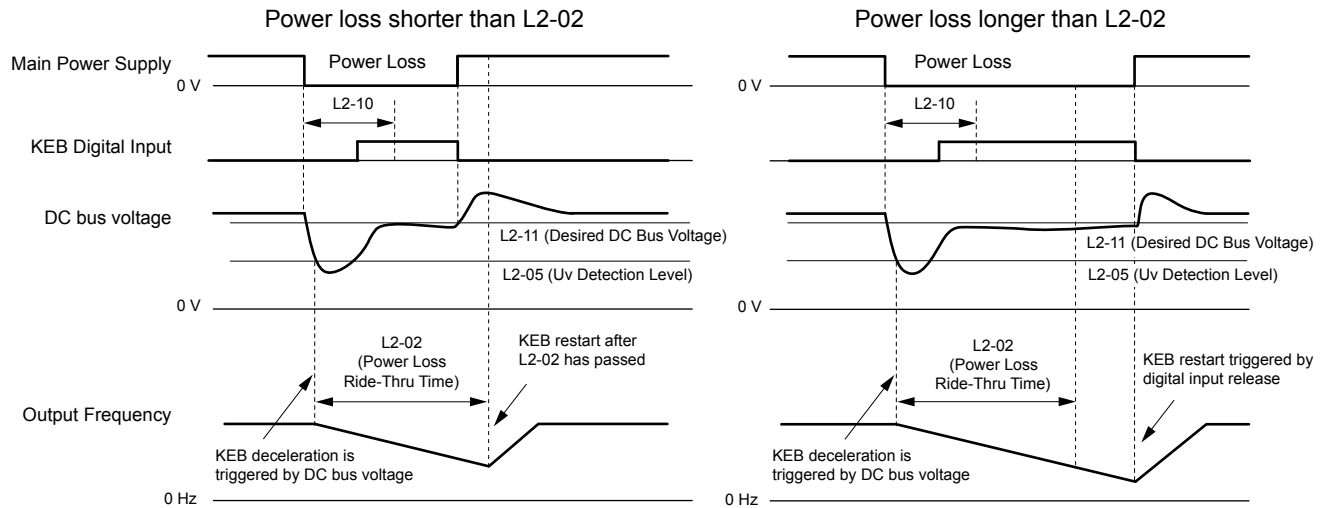

Figure 5.97 KEB Operation Using L2-02 and KEB Input

KEB Ride-Thru Operation as Long as CPU Has Power, KEB Input Not Used

Here, L2-01 = 4 and the input terminals have not been set for KEB Ride-Thru (H1-□□ does not equal 65, 66, 7A, 7B). After decelerating for the time set to parameter L2-10, the drive checks the DC bus voltage level. Deceleration continues if the DC bus voltage is lower than the level set in L2-11. Normal operation resumes when the DC bus voltage rises above the value of L2-11.

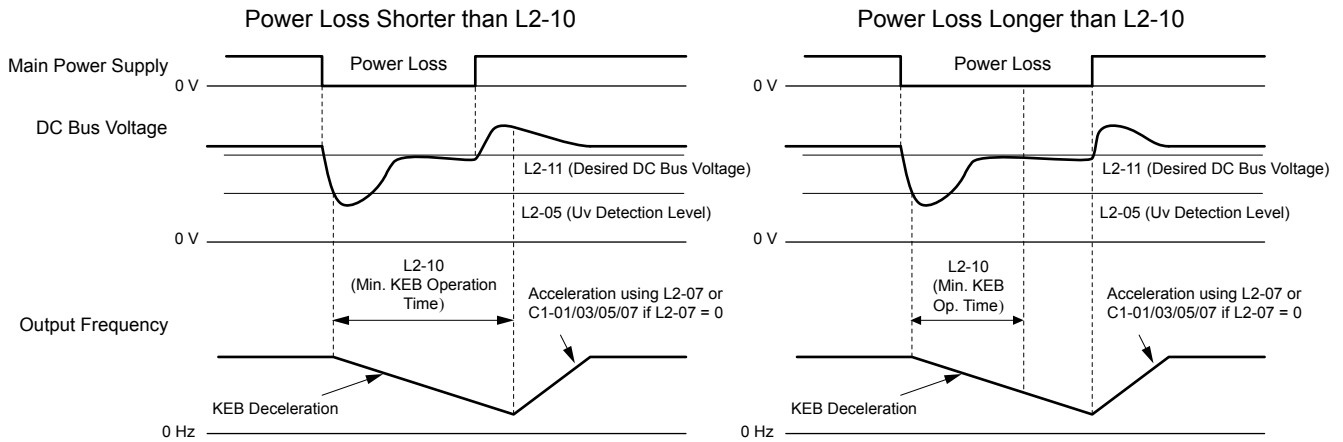

Figure 5.98 KEB Operation Using L2-10, Without KEB Input

KEB Ride-Thru Operation as Long as CPU Has Power, KEB Input Used

Here, L2-01 = 3 and an input terminal is set to issue KEB Ride-Thru (H1-□□ = 65, 66, 7A, 7B). After decelerating for the time set to parameter L2-10, the drive checks the DC bus voltage and the status of the digital input. Deceleration continues if the DC bus voltage is still below the level set in L2-11 or if the digital input assigned to KEB Ride-Thru is still active. Normal operation resumes when the DC bus voltage rises above the value of L2-11 and the terminal that initiated KEB Ride-Thru is released.

5.8 L: Protection Functions

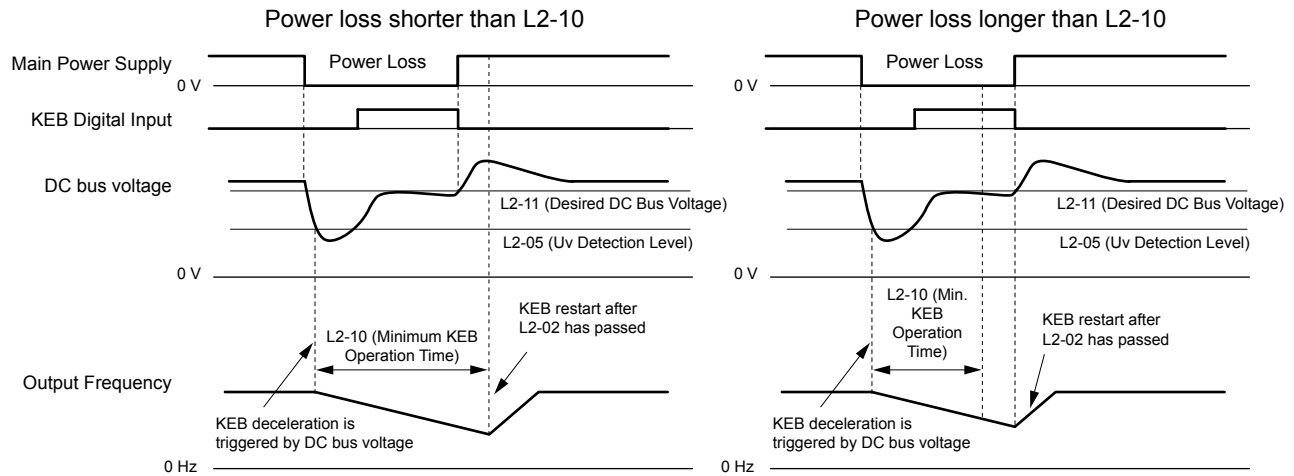

Figure 5.99 KEB Operation Using L2-10 and KEB Input

L2-01 = 5

KEB operation ends when the motor has come to a stop, even if the power returns and the digital input terminal that initiated KEB Ride-Thru is cleared.

■ KEB Operation Wiring Example

Figure 5.100 shows a wiring example to trigger the KEB Ride-Thru at power loss using an undervoltage relay. When a power loss occurs, the undervoltage relay triggers KEB Ride-Thru at terminal S6 (H1-06 = 65, 66, 7A, 7B). Note that using System KEB Ride-Thru requires an additional dynamic braking option.

- Note:**
1. Do not switch off the Run command during momentary power loss. If the Run command is shut off, the drive will not accelerate back to speed when the power is restored.
 2. A dynamic braking option is required to use System KEB 1 (L2-29 = 2).

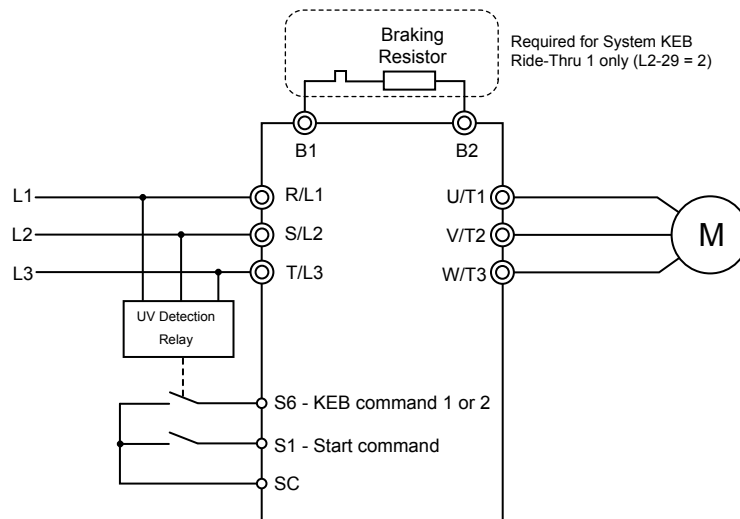

Figure 5.100 KEB Function Wiring Example

■ Parameters for KEB Ride-Thru

Table 5.43 lists parameters needed to set up KEB Ride-Thru depending on the type of KEB Ride-Thru selected in L2-29.

Table 5.43 KEB Function Related Adjustments

Parameter	Name	Setting Instructions	KEB Mode (L2-29)			
			0	1	2	3
C1-09	Fast Stop Time	<ul style="list-style-type: none"> Increase if an overvoltage fault occurs during KEB deceleration. Decrease if an undervoltage fault occurs during KEB deceleration. 	YES	NO	NO	NO
C2-03	S-Curve at Deceleration Start	<ul style="list-style-type: none"> Shorten if undervoltage occurs immediately after KEB Ride-Thru is triggered. Lengthen this setting if overvoltage occurs immediately after KEB operation starts. 	YES	NO	YES	YES
L2-05	Undervoltage Detection Level	Increase if an undervoltage fault occurs at KEB operation start to let the drive detect power loss more quickly.	YES	YES	YES	YES
L2-06	KEB Deceleration Time	<ul style="list-style-type: none"> Increase if an overvoltage fault occurs during KEB deceleration Decrease if an undervoltage fault occurs during KEB deceleration 	NO	NO	YES	YES
L2-07	KEB Acceleration Time	Adjust to the desired acceleration time. If set to 0, standard acceleration times are used (C1-01, C1-03, C1-05, C1-07).	YES	YES	YES	YES
L2-08	Frequency Gain at KEB Start	<ul style="list-style-type: none"> Increase if an undervoltage fault occurs immediately after KEB operation starts. Decrease if an overvoltage fault occurs immediately after KEB operation starts. 	YES	NO	YES	YES
L2-10	KEB Detection Time	<ul style="list-style-type: none"> Increase when a digital input is set for KEB Ride-Thru and an undervoltage fault occurs after power was lost because the device controlling the input does not react quickly enough. If the DC bus voltage overshoots after KEB Ride-Thru begins (and no input terminal is set to KEB Ride-Thru), increase L2-10 to longer than the overshoot. 	YES	YES	YES	YES
L2-11	Desired DC Bus Voltage during KEB	<ul style="list-style-type: none"> Set to approximately 1.22 times the input voltage for Single Drive KEB Ride-Thru 2. Set to approximately 1.4 times the input voltage for Single Drive KEB Ride-Thru 1 and System KEB Ride-Thru modes. 	YES	YES	YES	YES
L3-20	Main Circuit Adjustment Gain	<ul style="list-style-type: none"> Increase this setting in steps of 0.1 if overvoltage or undervoltage occurs at the beginning of deceleration Reduce if torque ripple occurs during deceleration while executing KEB Ride-Thru. 	NO	YES	NO	NO
L3-21	Accel/Decel Rate Calculation Gain	<ul style="list-style-type: none"> Reduce L3-21 in steps of 0.05 if there is a fairly large speed or current ripple. Decreasing this setting too much can cause a slow DC bus voltage control response, and may lead to problems with overvoltage or undervoltage. 	NO	YES	NO	NO
L3-24	Motor Acceleration Time	Set the motor acceleration time as described on page 298.	NO	YES	NO	NO
L3-25	Load Inertia Ratio	Set the load/inertia ratio as described on page 299.	NO	YES	NO	NO

■ L2-02: Momentary Power Loss Ride-Thru Time

Sets the maximum time allowed to ride through a power loss. If power loss operation exceeds this time, the drive will attempt to accelerate back to the frequency reference. This parameter is valid if L2-01 = 1 or 3.

Note: The amount of time the drive is capable of recovering after a power loss is determined by the capacity of the drive. Drive capacity determines the upper limit for L2-02.

No.	Name	Setting Range	Default
L2-02	Momentary Power Loss Ride-Thru Time	0.0 to 25.5 s	Determined by C6-01 and o2-04

■ L2-03: Momentary Power Loss Minimum Baseblock Time

Sets the minimum baseblock time when power is restored following a momentary power loss. This determines the time the drive waits for the residual voltage in the motor to dissipate. Increase this setting if overcurrent or overvoltage occurs at the beginning of Speed Search, after a power loss, or during DC Injection Braking.

5.8 L: Protection Functions

No.	Name	Setting Range	Default
L2-03	Momentary Power Loss Minimum Baseblock Time	0.1 to 5.0 s	Determined by C6-01 and o2-04

■ L2-04: Momentary Power Loss Voltage Recovery Ramp Time

Sets the time for the drive to restore the output voltage to the level specified by the V/f pattern after Speed Search. The setting value determines the time for the voltage to go from 0 V to the maximum voltage.

No.	Name	Setting Range	Default
L2-04	Momentary Power Loss Voltage Recovery Ramp Time	0.0 to 5.0 s	Determined by C6-01 and o2-04

■ L2-05: Undervoltage Detection Level (Uv)

Determines the voltage at which a Uv1 fault is triggered or at which the KEB function is activated. This setting rarely needs to be changed.

No.	Name	Setting Range	Default
L2-05	Undervoltage Detection Level	150 to 210 Vdc <1>	Determined by E1-01 <2>

<1> Values are specific to 200 V class drives. Double the value for 400 V class drives. Multiply the value by 2.875 for 600 V class drives.

<2> The default setting for 400 V class drives depends on whether the drive input voltage is over 400 V or under 400 V.

- Note:**
1. Install an AC reactor option on the input side of the power supply when setting L2-05 below the default value to prevent damage to drive circuitry.
 2. If using KEB Ride-Thru and L2-05 is set too low, then undervoltage in the DC bus (Uv1) will be triggered before KEB Ride-Thru can be executed. Take caution not to set this value too low.

■ L2-06: KEB Deceleration Time

Sets the time to decelerate from the frequency reference at the time KEB Ride-Thru was initiated to zero speed. This setting can be used only when L2-29 = 2 (System KEB Ride-Thru 1).

No.	Name	Setting Range	Default
L2-06	KEB Deceleration Time	0.00 to 6000.0 s <1>	0.00 s

<1> Setting range is determined by the accel/decel time units set in C1-10. If the time is set in units of 0.01 s (C1-10 = 0), the setting range becomes 0.00 to 600.00 s.

■ L2-07: KEB Acceleration Time

Sets the time to reaccelerate from the speed when KEB was deactivated to the frequency reference.

When set to 0.0 s, the drive will accelerate to speed according to the active deceleration time set by C1-01, C1-03, C1-05, or C1-07.

No.	Name	Setting Range	Default
L2-07	KEB Acceleration Time	0.00 to 6000.0 s <1>	0.00 s

<1> Setting range is determined by the accel/decel time units set in C1-10. If the time is set in units of 0.01 s (C1-10 = 0), the setting range becomes 0.00 to 600.00 s.

■ L2-08: Frequency Gain at KEB Start

When the KEB Ride-Thru command is input, the output frequency is reduced in a single step to quickly get the motor into a regenerative state. Calculate the amount of this frequency reduction using the formula below. L2-08 can only be used with induction motors.

Amount of reduction = Slip frequency prior to KEB × (L2-08) × 2

No.	Name	Setting Range	Default
L2-08	Frequency Gain at KEB Start	0 to 300%	100%

■ L2-10: KEB Detection Time (Minimum KEB Time)

Determines the duration of KEB Ride-Thru operation after it is triggered. *Refer to KEB Ride-Thru End Detection on page 288* for details.

No.	Name	Setting Range	Default
L2-10	KEB Detection Time	0 to 2000 ms	50 ms

■ L2-11: DC Bus Voltage Setpoint during KEB

Determines the setpoint (target value) for the DC bus voltage during Single KEB Ride-Thru 2. For Single KEB Ride-Thru 1 and System KEB Ride-Thru, parameter L2-11 defines the voltage level to end KEB Ride-Thru.

No.	Name	Setting Range	Default
L2-11	DC Bus Voltage Setpoint during KEB	150 to 400 Vdc </>	Determined by E1-01

<1> Values are specific to 200 V class drives. Double the value for 400 V class drives. Multiply the value by 2.875 for 600 V class drives.

■ L2-29: KEB Method Selection

Selects the way the Kinetic Energy Buffering function operates.

Note: If a multi function input is set for Single KEB Ride-Thru 2 (H1-□□ = 7A, 7B), the setting of L2-29 is disregarded and the KEB mode equal to L2-29 = 1 is automatically selected.

No.	Name	Setting Range	Default
L2-29	KEB Method Selection	0 to 3	0

Setting 0: Single Drive KEB Ride-Thru 1

Setting 1: Single Drive KEB Ride-Thru 2

Setting 2: System KEB Ride-Thru 1

Setting 3: System KEB Ride-Thru 2

Refer to KEB Ride-Thru Function on page 287 for detailed explanations.

◆ L3: Stall Prevention

The motor may experience excessive slip because it cannot keep up with the frequency reference when the load is too high or acceleration and deceleration times are too short. If the motor slips during acceleration, it usually causes an overcurrent fault (oC), drive overload (oL2), or motor overload (oL1). If the motor slips during deceleration, it can cause excessive regenerative power to flow back into the DC bus capacitors, and eventually cause the drive to fault out from overvoltage (oV). The Stall Prevention Function prevents the motor from stalling and while allowing the motor to reach the desired speed without requiring the user to change the acceleration or deceleration time settings. The Stall Prevention function can be set separately for acceleration, operating at constant speeds, and deceleration.

■ L3-01: Stall Prevention Selection during Acceleration

Stall Prevention during acceleration prevents tripping with overcurrent (oC), motor overload (oL1), or drive overload (oL2) faults common when accelerating with heavy loads.

L3-01 determines the type of Stall prevention the drive should use during acceleration.

No.	Name	Setting Range	Default
L3-01	Stall Prevention Selection during Acceleration	0 to 2 </>	1

<1> Setting 2 is not available for OLV/PM.

Setting 0: Disabled

No Stall Prevention is provided. If the acceleration time is too short, the drive may not be able to get the motor up to speed fast enough, causing an overload fault.

Setting 1: Enabled

Enables Stall Prevention during acceleration. Operation varies depending on the control mode.

- V/f Control, V/f Control with PG, and Open Loop Vector Control:

Acceleration is reduced when the output current value exceeds 85% of the level set to parameter L3-02 for a longer than the time set to L3-27. The acceleration stops when the current exceeds L3-02. Acceleration continues when the current falls below L3-02 for longer than the time set to L3-27.

5.8 L: Protection Functions

The Stall Prevention level is automatically reduced in the constant power range. *Refer to L3-03: Stall Prevention Limit during Acceleration on page 295.*

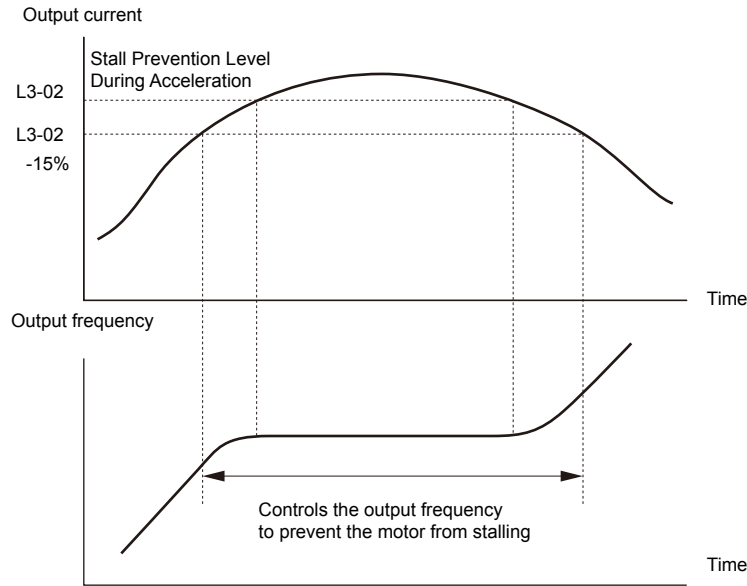

Figure 5.101 Stall Prevention During Acceleration for Induction Motors

- Open Loop Vector Control for PM:

Acceleration stops when the output current reaches the level set to parameter L3-02. When the time set to parameter L3-27 passes, the drive decelerates using the deceleration time set to L3-22 (*Refer to L3-22: Deceleration Time at Stall Prevention during Acceleration on page 295*). Deceleration stops when the current falls below 85% of L3-02. The drive will attempt to reaccelerate after the time set to L3-27.

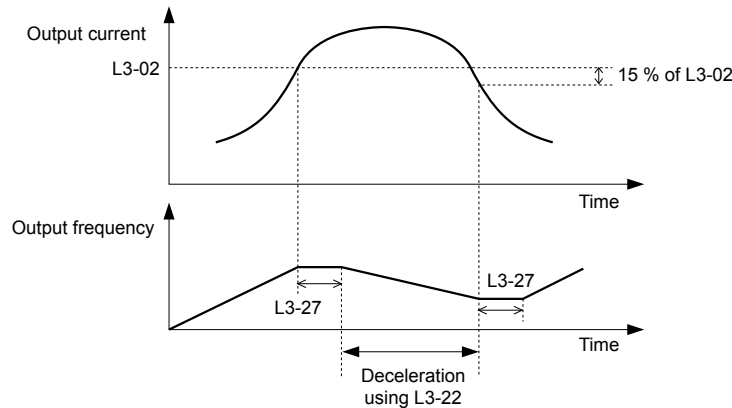

Figure 5.102 Stall Prevention During Acceleration for Permanent Magnet Motors

Note: PM motor control modes are not available on 600 V class drives, models 5A□□□□.

Setting 2: Intelligent Stall Prevention

The drive disregards the selected acceleration time and attempts to accelerate in the minimum time. The acceleration rate is adjusted so the current does not exceed the value set to parameter L3-02.

■ L3-02: Stall Prevention Level during Acceleration

Sets the output current level at which the Stall Prevention during acceleration is activated.

No.	Name	Setting Range	Default
L3-02	Stall Prevention Level during Acceleration	0 to 150% <1>	<1>

<1> The upper limit and default value is determined by the duty rating and the carrier frequency derating selection (C6-01 and L8-38 respectively).

- Lower L3-02 if stalling occurs when using a motor that is relatively small compared to the drive.

- Also set parameter L3-03 when operating the motor in the constant power range.

■ L3-03: Stall Prevention Limit during Acceleration

The Stall Prevention level is automatically reduced when the motor is operated in the constant power range. L3-03 sets the lower limit for this reduction as a percentage of the drive rated current.

No.	Name	Setting Range	Default
L3-03	Stall Prevention Limit during Acceleration	0 to 100%	50%

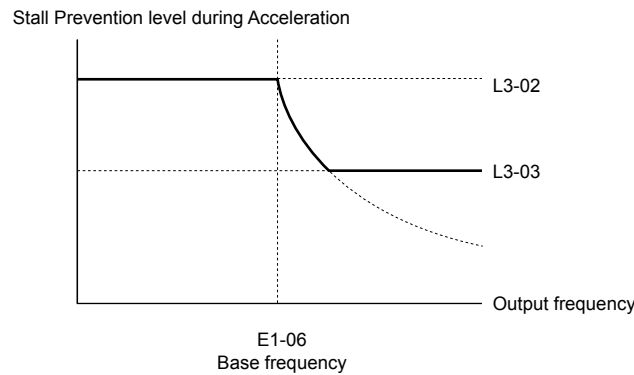

Figure 5.103 Stall Prevention Level and Limit During Acceleration

■ L3-22: Deceleration Time at Stall Prevention during Acceleration

Sets the brief deceleration time used when stalling occurs while accelerating a PM motor. When set to 0, this function is disabled and the drive decelerates at the selected deceleration time when stalling occurs.

The function is effective only in OLV/ PM control and when parameter L3-01 is set to 1.

No.	Name	Setting Range	Default
L3-22	Deceleration Time at Stall Prevention During Acceleration	0.0 to 6000.0 s	0.0 s

■ L3-04: Stall Prevention Selection during Deceleration

Stall Prevention during deceleration controls the deceleration based on the DC bus voltage and prevents an overvoltage fault caused by high inertia or rapid deceleration.

No.	Name	Setting Range	Default
L3-04	Stall Prevention Selection During Deceleration	0 to 5 <I>	1

<I> Settings 3 through 5 are not available in OLV/PM. Settings 2 through 5 are not available in AOLV/PM and CLV/PM.

Setting 0: Disabled

The drive decelerates according to the set deceleration time. With high inertia loads or rapid deceleration, an overvoltage fault may occur. If an overvoltage fault occurs, use dynamic braking options or switch to another L3-04 selection.

Setting 1: General-purpose Stall Prevention

The drive tries to decelerate within the set deceleration time. The drive pauses deceleration when the DC bus voltage exceeds the Stall Prevention level and then continues deceleration when the DC bus voltage drops below that level. Stall Prevention may be triggered repeatedly to avoid an overvoltage fault. The DC bus voltage level for Stall Prevention depends on the input voltage setting E1-01.

Drive Input Voltage	Stall Prevention Level during Deceleration
200 V Class	377 Vdc
400 V Class	754 Vdc
600 V Class	1084 Vdc

- Note:**
1. Do not use this setting in combination with a Dynamic Braking Resistor or other dynamic braking options. If Stall Prevention during deceleration is enabled, it will be triggered before the braking resistor option can operate.
 2. This method may lengthen the total deceleration time compared to the set value. If this is not appropriate for the application consider using a dynamic braking option.

Figure 5.104 illustrates the function of Stall Prevention during deceleration.

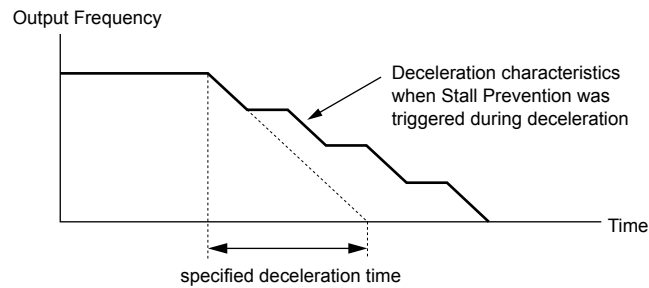

Figure 5.104 Stall Prevention During Deceleration

Setting 2: Intelligent Stall Prevention

The drive adjusts the deceleration rate so the DC bus voltage is kept at the level set to parameter L3-17. This produces the shortest possible deceleration time while protecting the motor from stalling. The selected deceleration time is disregarded and the achievable deceleration time cannot be smaller than 1/10 of the set deceleration time.

This function uses the following parameters for adjusting the deceleration rate:

- DC bus voltage gain (L3-20)
- Deceleration rate calculations gain (L3-21)
- Inertia calculations for motor acceleration time (L3-24)
- Load inertia ratio (L3-25)

Note: The deceleration time is not constant. Do not use Intelligent Stall Prevention in applications where stopping accuracy is a concern. Use dynamic braking options instead.

Setting 3: Stall Prevention with dynamic braking option

Enables the Stall Prevention function while using a dynamic braking resistor. Overvoltage problems in the DC bus can occur if Stall Prevention during deceleration is disabled (L3-04) in OLV and a dynamic braking option is installed. Set L3-04 to 3 to remedy this situation.

Setting 4: Overexcitation Deceleration 1

Overexcitation Deceleration 1 (increasing the motor flux) is faster than deceleration with no Stall Prevention (L3-04 = 0). Setting 4 changes the selected decel time and functions to provide protection from an overvoltage trip. [Refer to Overexcitation Deceleration \(Induction Motors\) on page 315](#) for details.

Setting 5: Overexcitation Deceleration 2

Overexcitation Deceleration 2 slows down the motor while trying to maintain the DC bus voltage at the level set to parameter L3-17. This function shortens the achievable deceleration time more than by using Overexcitation Deceleration 1. Setting 5 will shorten/lengthen the decel time to maintain the L3-17 bus level. [Refer to Overexcitation Deceleration \(Induction Motors\) on page 315](#) for details.

■ L3-05: Stall Prevention Selection during Run

Determines how Stall Prevention works during Run. Stall Prevention during run prevents the motor from stalling by automatically reducing the speed when a transient overload occurs while the motor is running at constant speed.

No.	Name	Setting Range	Default
L3-05	Stall Prevention Selection During Run	0 to 2	1

- Note:**
1. This parameter is available in V/f, V/f w/PG, and OLV/PM.
 2. Stall Prevention during run is disabled when the output frequency is 6 Hz or lower regardless of the L3-05 and L3-06 settings.

Setting 0: Disabled

Drive runs at the set frequency reference. A heavy load may cause the motor to stall and trip the drive with an oC or oL fault.

Setting 1: Decelerate using C1-02

If the current exceeds the Stall Prevention level set in parameter L3-06, the drive will decelerate at decel time 1 (C1-02). When the current level drops below the value of L3-06 minus 2% for 100 ms, the drive accelerates back to the frequency reference at the active acceleration time.

Setting 2: Decelerate using C1-04

Same as setting 1 except the drive decelerates at decel time 2 (C1-04).

■ L3-06: Stall Prevention Level during Run

Sets the current level to trigger Stall Prevention during run. Depending on the setting of parameter L3-23, the level is automatically reduced in the constant power range (speed beyond base speed). A setting of 100% is equal to the drive rated current.

The Stall Prevention level can be adjusted using an analog input. *Refer to Multi-Function Analog Input Terminal Settings on page 271* for details.

No.	Name	Setting Range	Default
L3-06	Stall Prevention Level During Run	30 to 150% <I>	<I>

<I> The upper limit and default for this setting is determined by C6-01 and L8-38.

■ L3-23: Automatic Reduction Selection for Stall Prevention during Run

Reduces the Stall Prevention during run level in the constant power range.

No.	Name	Setting Range	Default
L3-23	Automatic Reduction Selection for Stall Prevention During Run	0, 1	0

Setting 0: Disabled

The level set in L3-06 is used throughout the entire speed range.

Setting 1: Enabled

The Stall Prevention level during run is reduced in the constant power range. The lower limit will be 40% of L3-06.

■ Overvoltage Suppression Function

Suppresses overvoltage faults by decreasing the regenerative torque limit and slightly increasing the output frequency when the DC bus voltage rises. This function can drive loads with cyclic regenerative operation, such as a punch press or other applications that involve repetitive crank movements.

The regenerative torque limit and the output frequency are adjusted during ov suppression so that the DC bus voltage does not exceed the level set to parameter L3-17. In addition to the parameters explained below, ov suppression also uses these settings for frequency adjustment:

- DC bus voltage gain (L3-20)
- Deceleration rate calculations gain (L3-21)
- Inertia calculations for motor acceleration time (L3-24)
- Load inertia ratio (L3-25)

- Note:**
1. The motor speed will exceed the frequency reference when overvoltage suppression is triggered. Consequently, overvoltage suppression is not appropriate in applications that require a perfect match between the frequency reference and the motor speed.
 2. Disable overvoltage suppression when using a braking resistor.
 3. Overvoltage may still occur if there is a sudden increase to a regenerative load.
 4. This function is enabled only when operating just below the maximum frequency. Overvoltage suppression does not increase the output frequency beyond the maximum frequency. If the application requires this, increase the maximum frequency and change the base frequency setting.

■ L3-11: Overvoltage Suppression Function Selection

Enables or disables the overvoltage suppression function.

No.	Name	Setting Range	Default
L3-11	Overvoltage Suppression Function Selection	0, 1	0

Setting 0: Disabled

The regenerative torque limit and the output frequency are not adjusted. A regenerative load may trip the drive with an overvoltage fault. Use this setting if dynamic braking options are installed.

Setting 1: Enabled

When the DC bus voltage rises due to regenerative load, an overvoltage fault is prevented by decreasing the regenerative torque limit and increasing the output frequency.

■ L3-17: Target DC Bus Voltage for Overvoltage Suppression and Stall Prevention

Sets the target DC bus voltage level used by the overvoltage suppression function (L3-11 = 1), Intelligent Stall Prevention during deceleration (L3-04 = 2).

5.8 L: Protection Functions

No.	Name	Setting Range	Default
L3-17	Target DC Bus Voltage for Overvoltage Suppression and Stall Prevention	150 to 400 Vdc <1>	375 Vdc <1> <2>

<1> Values are specific to 200 V class drives. Double the value for 400 V class drives. Multiply the value by 2.875 for 600 V class drives, but set the value below 1040 Vdc (overvoltage protection level).

<2> This value is initialized when E1-01 is changed.

■ L3-20: DC Bus Voltage Adjustment Gain

Determines the proportional gain used by overvoltage suppression (L3-11 = 1), Single Drive KEB 2 (L2-29 = 1), KEB Ride-Thru 2 (H1-□□ = 7A or 7B), and Intelligent Stall Prevention during deceleration (L3-04 = 2) to control the DC bus voltage.

No.	Name	Setting Range	Default
L3-20	DC Bus Voltage Adjustment Gain	0.00 to 5.00	Determined by A1-02

Adjustment for Single Drive KEB 2 (L2-29 = 1) and Intelligent Stall Prevention During Deceleration

- Increase this setting slowly in steps of 0.1 if overvoltage or undervoltage occurs at the beginning of deceleration.
- Decrease this setting if there is a fair amount of speed or torque ripple.

Adjustment for Overvoltage Suppression

- Increase this setting slowly in steps of 0.1 if overvoltage suppression is enabled (L3-11 = 1) and a sudden increase in a regenerative load causes an overvoltage fault.
- Decrease this setting if there is a fair amount of speed or torque ripple.

■ L3-21: Accel/Decel Rate Calculation Gain

Determines the proportional gain used by overvoltage suppression (L3-11 = 1), Single Drive KEB 2 (L2-29 = 1), and Intelligent Stall Prevention during deceleration (L3-04 = 2) to calculate acceleration and deceleration rates.

No.	Name	Setting Range	Default
L3-21	Accel/Decel Rate Calculation Gain	0.10 to 10.00	<1>

<1> This value is reset to its default value when the control mode is changed (A1-02). The value shown here is for OLV.

Adjustment for Single Drive KEB 2 (L2-29 = 1) and Intelligent Stall Prevention During Deceleration

- Reduce L3-21 in steps of 0.05 if there is a fairly large speed or current ripple.
- Small reductions of L3-21 can help solve problems with overvoltage and overcurrent.
- Decreasing this setting too much can cause slow DC bus voltage control response and may also lengthen deceleration times beyond optimal levels.

Adjustment for Overvoltage Suppression

- Increase this setting in steps of 0.1 if overvoltage occurs as a result of a regenerative load when overvoltage suppression is enabled (L3-11 = 1).
- Decrease L3-21 in steps of 0.05 if there is a fairly large speed ripple when overvoltage suppression is enabled.

■ L3-24: Motor Acceleration Time for Inertia Calculations

Sets the time to accelerate the motor from stop to the maximum speed at motor rated torque. Set this parameter when using Single Drive KEB 2 (L2-29 = 1), Intelligent Stall Prevention during Deceleration (L3-04 = 2), or the Overvoltage Suppression function (L3-11 = 1).

No.	Name	Setting Range	Default
L3-24	Motor Acceleration Time for Inertia Calculations	0.001 to 10.000 s	Determined by o2-04, C6-01, E2-11, and E5-01 <1>

<1> Parameter L3-24 is defaulted for a Yaskawa standard 4-pole motor. During Auto-Tuning, L3-24 will be initialized to a Yaskawa standard 4-pole motor if parameter E2-11 is changed. This value also changes based on the motor code set to E5-01 when using OLV/PM.

Automatic Parameter Setup

In CLV/PM, use the Inertia Auto-Tuning function to let the drive automatically adjust this parameter. *Refer to Auto-Tuning on page 135.*

Manual Parameter Setup

Make the calculations in the formula below:

$$L3-24 = \frac{2 \cdot \pi \cdot J [\text{kgm}^2] \cdot n_{\text{rated}} [\text{r/min}]}{60 \cdot T_{\text{rated}} [\text{Nm}]}$$

Calculate the rated torque in the formula below:

$$T_{\text{rated}} [\text{Nm}] = \frac{60 \cdot P_{\text{Motor}} [\text{kW}] \cdot 10^3}{2 \cdot \pi \cdot n_{\text{rated}} [\text{r/min}]}$$

■ L3-25: Load Inertia Ratio

Determines the ratio between the rotor inertia and the load. Set this parameter when using Single Drive KEB 2 (L2-29 = 1), Intelligent Stall Prevention during deceleration (L3-04 = 2), or the overvoltage suppression function (L3-11 = 1).

No.	Name	Setting Range	Default
L3-25	Load Inertia Ratio	1.0 to 1000.0	1.0

When set incorrectly, a fairly large current ripple can result during Single Drive KEB 2 (L2-29 = 1). This may cause overvoltage suppression (L3-11 = 1) or other faults such as ov, Uv1, and oC.

Automatic Parameter Setup

In CLV for induction motors or PM motors, use the Inertia Auto-Tuning function to let the drive automatically adjust this parameter. *Refer to Auto-Tuning on page 135.*

Manual Parameter Setup

Calculate parameter L3-25 in the formula below:

$$L3-25 = \frac{\text{Machine Inertia}}{\text{Motor Inertia}}$$

■ L3-26: Additional DC Bus Capacitors

Sets the capacity of any additionally installed DC bus capacitors. This data is used in calculations for Single Drive KEB Ride-Thru 2. Adjust this setting only if external capacity is connected to the DC bus and Single Drive KEB 2 is used.

No.	Name	Setting Range	Default
L3-26	Additional DC Bus Capacitors	0 to 65000 μF	0 μF

■ L3-27: Stall Prevention Detection Time

Sets a delay time from when the Stall Prevention level is reached and the actual Stall Prevention function is activated.

No.	Name	Setting Range	Default
L3-27	Stall Prevention Detection Time	0 to 5000 ms	50 ms

■ L3-34: Torque Limit Delay Time

Sets the filter time constant in seconds for the torque limit value to return to set value when the Power KEB Ride-Thru is enabled (L2-29 = 1). Gradually increase this setting in increments of 0.010 s if oscillation occurs during Power KEB Ride-Thru.

Note: This parameter is not available in models 4A0930 and 4A1200.

No.	Name	Setting Range	Default
L3-34	Torque Limit Delay Time	0.000 to 1.000 s	Determined by A1-02 <>

<1> L3-34 = 0.200 when A1-02 = 6, L3-34 = 0.020 when A1-02 = 7.

◆ L4: Speed Detection

These parameters set up the speed agree and speed detection functions that can be assigned to the multi-function output terminals.

The speed is detected using the motor speed when A1-02 = 3 or 7.

5.8 L: Protection Functions

■ L4-01, L4-02: Speed Agreement Detection Level and Detection Width

Parameter L4-01 sets the detection level for the digital output functions Speed agree 1, User-set speed agree 1, Frequency detection 1, and Frequency detection 2.

Parameter L4-02 sets the hysteresis level for these functions.

No.	Name	Setting Range	Default
L4-01	Speed Agreement Detection Level	0.0 to 400.0 Hz	0.0 Hz
L4-02	Speed Agreement Detection Width	0.0 to 20.0 Hz	Determined by A1-02

Refer to H2-01 to H2-03: Terminal M1-M2, M3-M4, and M5-M6 Function Selection on page 258, Settings 2, 3, 4, and 5.

■ L4-03, L4-04: Speed Agreement Detection Level and Detection Width (+/-)

Parameter L4-03 sets the detection level for the digital output functions Speed agree 2, User-set speed agree 2, Frequency detection 3, and Frequency detection 4.

Parameter L4-04 sets the hysteresis level for these functions.

No.	Name	Setting Range	Default
L4-03	Speed Agreement Detection Level (+/-)	-400.0 to 400.0 Hz	0.0 Hz
L4-04	Speed Agreement Detection Width (+/-)	0.0 to 20.0 Hz	Determined by A1-02

Refer to H2-01 to H2-03: Terminal M1-M2, M3-M4, and M5-M6 Function Selection on page 258, Settings 13, 14, 15, and 16.

■ L4-05: Frequency Reference Loss Detection Selection

The drive can detect a loss of an analog frequency reference from input A1, A2, or A3. Frequency reference loss is detected when the frequency reference drops below 10% of the reference or below 5% of the maximum output frequency within 400 ms.

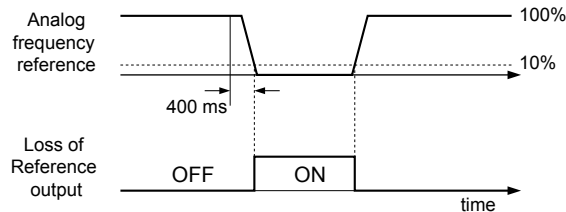

Figure 5.105 Loss of Reference Function

Set H2-01, H2-02, or H2-03 to C for a digital output to trigger when frequency reference loss occurs. *Refer to Setting C: Frequency Reference Loss on page 262* for details on setting the output function.

Parameter L4-05 selects the operation when a frequency reference loss is detected.

No.	Name	Setting Range	Default
L4-05	Frequency Reference Loss Detection Selection	0, 1	0

Setting 0: Stop

Drive follows the frequency reference (which is no longer present) and stops the motor.

Setting 1: Continue operation with reduced frequency reference

The drive will continue operation at the frequency reference value set to parameter L4-06. When the external frequency reference value is restored, the operation is continued with the frequency reference.

■ L4-06: Frequency Reference at Reference Loss

Sets the frequency reference level at which the drive runs when L4-05 = 1 and when detecting a reference loss. The value is set as a percentage of the frequency reference before the loss was detected.

No.	Name	Setting Range	Default
L4-06	Frequency Reference at Reference Loss	0.0 to 100.0%	80.0%

■ L4-07: Speed Agreement Detection Selection

Determines when frequency detection is active using parameters L4-01 through L4-04.

No.	Name	Setting Range	Default
L4-07	Speed Agreement Detection Selection	0, 1	0

Setting 0: No Detection during Baseblock

Setting 1: Detection always Enabled

◆ L5: Fault Restart

After a fault has occurred, Fault Restart attempts to automatically restart the motor and continue operation instead of stopping. The drive can perform a self-diagnostic check and resume the operation after a fault has occurred. If the self-check is successful and the cause of the fault has disappeared, the drive restarts by first performing Speed Search (*Refer to b3: Speed Search on page 173* for details).

- Note:**
1. The wiring sequence should remove the Forward/Reverse command when a fault is triggered and output is shut off.
 2. When the Forward/Reverse command is removed, the drive can perform a self-diagnostic check and attempt to restart the fault automatically.

WARNING! *Sudden Movement Hazard. Do not use the fault restart function in lifting applications. Fault restart may cause the machine to drop the load, which could result in death or serious injury.*

The drive can attempt to restart itself following the faults listed below.

Fault	Name	Fault	Name
GF	Ground Fault	oL4	Overtorque 2
LF	Output Open Phase	ov	DC Bus Overvoltage
oC	Overcurrent	PF	Input Phase Loss
oH1	Drive Overheat	rH	Braking Resistor Fault
oL1	Motor Overload	rr	Braking Transistor Fault
oL2	Drive Overload	Uv1	DC Bus Undervoltage <1>
oL3	Overtorque 1	STo	Pull-Out Detection

<1> When L2-01 is set to 1 through 4 (continue operation during momentary power loss)

Use parameters L5-01 to L5-05 to set up automatic fault restart.

Set H2-01, H2-02, or H2-03 to 1E. to output a signal during fault restart.

■ L5-01: Number of Auto Restart Attempts

Sets the number of times that the drive may attempt to restart itself.

Parameter L5-05 determines the method of incrementing the restart counter. When the counter reaches the number set to L5-01, the operation stops and the fault must be manually cleared and reset.

The restart counter is incremented at each restart attempt, regardless of whether the attempt was successful. When the counter reaches the number set to L5-01, the operation stops and the fault must be manually cleared and reset.

The number of fault restarts is reset to zero when:

- The drive operates normally for 10 minutes following a fault restart.
- A fault is cleared manually after protective functions are triggered.
- The power supply is cycled.

No.	Name	Setting Range	Default
L5-01	Number of Auto Restart Attempts	0 to 10 Times	0 Times

■ L5-02: Auto Restart Fault Output Operation Selection

Determines if a fault output is triggered (H2-□□ = E) when the drive attempts to restart.

No.	Name	Setting Range	Default
L5-02	Auto Restart Fault Output Operation Selection	0, 1	0

5.8 L: Protection Functions

Setting 0: No Fault Output

Setting 1: Fault Output Is Set

■ L5-04: Fault Reset Interval Time

Determines the amount of time to wait between restart attempts when parameter L5-05 is set to 1.

No.	Name	Setting Range	Default
L5-04	Fault Reset Interval Time	0.5 to 600.0 s	10.0 s

■ L5-05: Fault Reset Operation Selection

No.	Name	Setting Range	Default
L5-05	Fault Reset Operation Selection	0, 1	0

Setting 0: Count Successful Restarts

The drive will continuously attempt to restart. If it restarts successfully, the restart counter is increased. This operation is repeated each time a fault occurs until the counter reaches the value set to L5-01.

Setting 1: Count Restart Attempts

The drive will attempt to restart using the time interval set to parameter L5-04. A record is kept of the number of attempts to restart to the drive, regardless of whether those attempts were successful. When the number of attempted restarts exceeds the value set to L5-01, the drive stops attempting to restart.

◆ L6: Torque Detection

The drive provides two independent torque detection functions that trigger an alarm or fault signal when the load is too heavy (oL), or suddenly drops (UL). These functions are set up using the L6-□□ parameters. Program the digital outputs as shown below to indicate the underload or overload condition to an external device:

Note: When overtorque occurs in the application, the drive may stop due to overcurrent (oC) or overload (oL1). To prevent the drive from stopping, use torque detection to indicate an overload situation to the controller before oC or oL1 occur. Use undertorque detection to discover application problems like a torn belt, a pump shutting off, or other similar trouble.

H2-01, H2-02, H2-03 Setting	Description
B	Torque detection 1, N.O. (output closes when overload or underload is detected)
17	Torque detection 1, N.C. (output opens when overload or underload is detected)
18	Torque detection 2, N.O. (output closes when overload or underload is detected)
19	Torque detection 2, N.C. (output opens when overload or underload is detected)

Figure 5.106 and Figure 5.107 illustrate the functions of overtorque and undertorque detection.

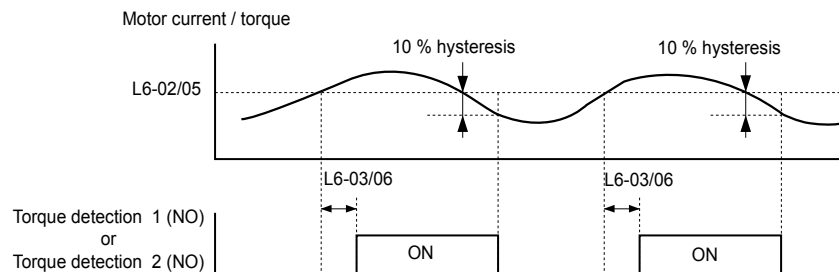

Figure 5.106 Overtorque Detection Operation

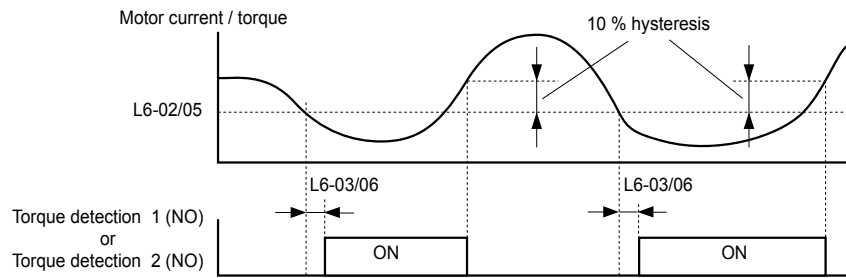

Figure 5.107 Undertorque Detection Operation

- Note:**
1. The torque detection function uses a hysteresis of 10% of the drive rated output current and motor rated torque.
 2. In V/f, V/f w/PG and OLV/PM, the level is set as a percentage of the drive rated output current. In OLV, CLV, AOLV/PM and CLV/PM, the level is set as a percentage of the motor rated torque.

■ L6-01, L6-04: Torque Detection Selection 1, 2

The torque detection function is triggered when the current or torque exceed the levels set to L6-02 and L6-05 for longer than the times set to L6-03 and L6-06. L6-01 and L6-04 select the conditions for detection and the operation that follows.

No.	Name	Setting Range	Default
L6-01	Torque Detection Selection 1	0 to 8	0
L6-04	Torque Detection Selection 2	0 to 8	0

Setting 0: Disabled

Setting 1: oL3, oL4 at speed agree (Alarm)

Overtorque detection is active only when the output speed is equal to the frequency reference (i.e., no detection during acceleration and deceleration). The operation continues after detecting overtorque and triggering an oL3/oL4 alarm.

Setting 2: oL3, oL4 at run (Alarm)

Overtorque detection works as long as the Run command is active. The operation continues after detecting overtorque and triggering an oL3/oL4 alarm.

Setting 3: oL3, oL4 at speed agree (Fault)

Overtorque detection is active only when the output speed is equal to the frequency reference, i.e., no detection during acceleration and deceleration. The operation stops and triggers an oL3/oL4 fault.

Setting 4: oL3, oL4 at run (Fault)

Overtorque detection works as long as a Run command is active. The operation stops and triggers an oL3/oL4 fault.

Setting 5: UL3, UL4 at speed agree (Alarm)

Undertorque detection is active only when the output speed is equal to the frequency reference, i.e., no detection during acceleration and deceleration. The operation continues after detecting overtorque and triggering a UL3/UL4 alarm.

Setting 6: UL3, UL4 at Run (Alarm)

Undertorque detection works as long as the Run command is active. The operation continues after detecting overtorque and triggering a UL3/UL4 alarm.

Setting 7: UL3, UL4 at Speed Agree (Fault)

Undertorque detection is active only when the output speed is equal to the frequency reference, i.e., no detection during acceleration and deceleration. The operation stops and triggers a UL3/UL4 fault.

Setting 8: UL3, UL4 at run (Fault)

Undertorque detection works as long as a Run command is active. The operation stops and triggers a UL3/UL4 fault.

■ L6-02, L6-05: Torque Detection Level 1, 2

These parameters set the detection levels for torque detection functions 1 and 2. In V/f and OLV/PM control modes, these levels are set as a percentage of the drive rated output current. In vector control modes, these levels are set as a percentage of the motor rated torque.

5.8 L: Protection Functions

No.	Name	Setting Range	Default
L6-02	Torque Detection Level 1	0 to 300%	150%
L6-05	Torque Detection Level 2	0 to 300%	150%

Note: The torque detection level 1 (L6-02) can also be supplied by an analog input terminal set to H3-□□ = 7. Here, the analog value has priority and the setting in L6-02 is disregarded. Torque detection level 2 (L6-05) cannot be set by an analog input.

■ L6-03, L6-06: Torque Detection Time 1, 2

These parameters determine the time required to trigger an alarm or fault after exceeding the levels in L6-02 and L6-05.

No.	Name	Setting Range	Default
L6-03	Torque Detection Time 1	0.0 to 10.0 s	0.1 s
L6-06	Torque Detection Time 2	0.0 to 10.0 s	0.1 s

■ Mechanical Weakening Detection

This function detects the mechanical weakening of a machine that leads to overtorque or undertorque situations after a set machine operation time has elapsed.

The function is activated in the drive when the cumulative operation counter U4-01 exceeds the time set to parameter L6-11. Mechanical Weakening Detection uses the torque detection 1 settings (L6-01, L6-02, L6-03) and triggers an oL5 or UL5 fault when overtorque or undertorque occurs in the speed range determined by parameter L6-08 and L6-09. The oL5 or UL5 operation is set by parameter L6-08.

Set H2-□□ to 22 to output a signal for Mechanical Weakening Detection.

■ L6-08: Mechanical Weakening Detection Operation

Sets the speed range to detect mechanical weakening and the action to take when mechanical weakening is detected.

No.	Name	Setting Range	Default
L6-08	Mechanical Weakening Detection Operation	0 to 8	0

Setting 0: Disabled

Setting 1: Continue running if the speed is greater than L6-09 (Signed) (Alarm)

Detection when the speed is above L6-09 (signed). Operation continues and triggers an oL5 alarm after detection.

Setting 2: Continue running if the speed is greater than L6-09 (Alarm)

Detection when the speed is above L6-09 (unsigned). Operation continues and triggers an oL5 alarm after detection.

Setting 3: Stop when motor speed is greater than L6-09 (Signed)

Detection when the speed is above L6-09 (signed). Operation stops and triggers an oL5 fault after detection.

Setting 4: Stop when Motor Speed is Greater than L6-09

Detection when the speed is above L6-09 (unsigned). Operation stops and triggers an oL5 fault after detection.

Setting 5: Continue running if the speed is less than L6-09 (Signed) (Alarm)

Detection when the speed is below L6-09 (signed). Operation continues and triggers a UL5 alarm after detection.

Setting 6: Continue running if the speed is less than L6-09 (Alarm)

Detection when the speed is below L6-09 (unsigned). Operation continues and triggers a UL5 alarm after detection.

Setting 7: Stop when Motor Speed is less than L6-09 (Signed)

Detection when the speed is below L6-09 (signed). Operation stops and triggers a UL5 fault after detection.

Setting 8: Stop when motor speed is less than L6-09

Detection when the speed is below L6-09 (unsigned). Operation stops and triggers a UL5 fault after detection.

■ L6-09: Mechanical Weakening Detection Speed Level

Sets the speed level for Mechanical Weakening Detection as a percentage of the maximum frequency. If L6-08 is set for unsigned speed detection (L6-08 = 2, 4, 6, 8), the absolute value of L6-09 is used (negative settings are treated as positive values).

No.	Name	Setting Range	Default
L6-09	Mechanical Weakening Detection Speed Level	-110.0 to 110.0%	110%

■ L6-10: Mechanical Weakening Detection Time

Sets the time permitted for the situation selected in parameter L6-08 to arise before detecting mechanical weakening.

No.	Name	Setting Range	Default
L6-10	Mechanical Weakening Detection Time	0.0 to 10.0 s	0.1 s

■ L6-11: Mechanical Weakening Detection Start Time

Sets the cumulative drive operation time at which Mechanical Weakening Detection is activated. The function activates when U4-01 reaches the L6-11 value.

No.	Name	Setting Range	Default
L6-11	Mechanical Weakening Detection Start Time	0 to 65535 h	0 h

◆ L7: Torque Limit

The torque limit function limits the torque in each of the four quadrants individually to protect machinery in OLV, CLV, AOLV/PM, and CLV/PM control modes. Set the limit through parameters, analog inputs, or by switching a digital output programmed for “During torque limit” (H2-01, H2-02, H2-03 = 30) when the drive is operating at the torque limit.

■ Setting Torque Limits

Parameters L7-01 to L7-04 define the torque limits for each of the four operation quadrants. It is also possible to use Analog inputs to define a general limit for all operation conditions (H3-02, H3-06, H3-10 = 15) or to set separate limits for each operation condition (H3-02, H3-06, H3-10 = 10, 11, or 12). *Figure 5.108* shows limit setting is applied in each quadrant.

If two limit values are defined for the same operation conditions, the drive will use the lower value.

Note: The maximum output torque is ultimately limited by the drive output current (max. 150% of drive rated current in HD, 120% in ND). Output torque will not exceed the drive rated current limit even if the torque limits are set to higher values.

Example: If parameter L7-01 = 130%, L7-02 to L7-04 = 200%, and an analog input sets a general torque limit of 150% (H3-02, H3-06, H3-10 = 15), then the torque limit will be 130% in quadrant 1, but 150% in the other quadrants.

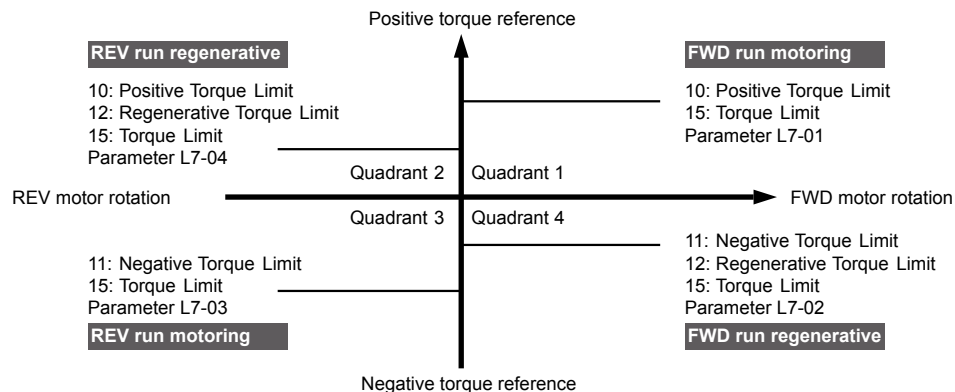

Figure 5.108 Torque Limit Parameters and Analog Input Settings

■ L7-01 to L7-04: Torque Limits

These parameters set the torque limits in each operation mode.

No.	Name	Setting Range	Default
L7-01	Forward Torque Limit	0 to 300%	200%
L7-02	Reverse Torque Limit	0 to 300%	200%
L7-03	Forward Regenerative Torque Limit	0 to 300%	200%
L7-04	Reverse Regenerative Torque Limit	0 to 300%	200%

Note: If the multi-function analog input is programmed for “10: Forward torque limit”, “11: Reverse torque limit”, “12: Regenerative torque limit”, or “15: General torque limit”, the drive uses the lowest value from L7-01 through L7-04, or analog input torque limit.

5.8 L: Protection Functions

■ L7-06: Torque Limit Integral Time Constant

Sets the integral time constant for the torque limit function. Decrease the setting for faster torque limit response. Increase the setting if oscillation occurs when operating at the torque limit.

No.	Name	Setting Range	Default
L7-06	Torque Limit Integral Time Constant	5 to 10000 ms	200 ms

■ L7-07: Torque Limit Control Method Selection during Accel/Decel

Selects the function of torque limit during acceleration and deceleration.

No.	Name	Setting Range	Default
L7-07	Torque Limit Control Method Selection during Accel/Decel	0, 1	0

Setting 0: Proportional control

The torque limit function works with P control during accel and decel, and switches to I control at constant speed. Use this setting when accelerating or decelerating to the desired speed has priority over the torque limit during speed changes.

Setting 1: Integral control

The torque limit function always uses I control. Use this setting when a highly accurate torque limit is required, even during speed changes. Using this function may increase the acceleration time, or prevent the motor speed from reaching the frequency reference if the torque limit is reached first.

■ L7-16: Torque Limit Process at Start

Assigns a time filter to allow the torque limit to build at start.

No.	Name	Setting Range	Default
L7-16	Torque Limit Process at Start	0, 1	1

Setting 0: Disabled

Torque limit is created at start without a delay time. Disable L7-16 to maximize the response time when the application requires sudden acceleration or deceleration at start.

Setting 1: Enabled

A delay time of 64 ms is added to allow the torque limit to build at start.

◆ L8: Drive Protection

■ L8-01: Internal Dynamic Braking Resistor Protection Selection (ERF type)

Selects the dynamic braking resistor protection when using an optional heatsink mounted braking resistor (ERF type, 3% ED).

Note: This parameter is not available in models 4A0930 and 4A1200.

No.	Name	Setting Range	Default
L8-01	Internal Dynamic Braking Resistor Protection Selection (ERF type)	0, 1	Determined by C6-01 and o2-04

Setting 0: Disabled

Disables braking resistor protection. Use this setting for any dynamic braking option other than the Yaskawa ERF-type resistor.

Setting 1: Enabled

Enables protection for Yaskawa ERF-type resistors.

■ L8-02: Overheat Alarm Level

Sets the overheat alarm (oH) detection level.

The drive outputs an alarm when the heatsink temperature exceeds the overheat alarm level. If the drive is set to continue operation after this alarm occurs (L8-03 = 4) and the temperature reaches the overheat fault level, the drive will trigger an oH1 fault and stop operation.

When an output terminal is set for the oH pre-alarm (H2-□□ = 20), the switch will close when the heatsink temperature rises above L8-02.

No.	Name	Setting Range	Default
L8-02	Overheat Alarm Level	50 to 150 °C	Determined by C6-01 and o2-04

■ L8-03: Overheat Pre-Alarm Operation Selection

Sets the operation when an overheat pre-alarm is detected.

Note: Change L8-03 setting only when necessary.

No.	Name	Setting Range	Default
L8-03	Overheat Pre-Alarm Operation Selection	0 to 4	3

Setting 0: Ramp to stop

If an overheat alarm occurs, the drive decelerates to stop using the currently selected deceleration time. If a digital output is programmed for “fault” (H2-□□ = E), this output will be triggered.

Setting 1: Coast to stop

If an overheat alarm occurs, the drive switches off the output and the motor coasts to stop. If a digital output is programmed for “fault” (H2-□□ = E), this output will be triggered.

Setting 2: Fast Stop

If an overheat alarm occurs, the drive decelerates to stop using the Fast Stop time (C1-09). If a digital output is programmed for “fault” (H2-□□ = E), this output will be triggered.

Setting 3: Alarm only

If an overheat alarm occurs, an alarm is output and the drive continues operation.

Setting 4: Operation with reduced speed

If an overheat alarm occurs, the operation continues with the speed reduced to the level set to parameter L8-19. If the oH alarm is still present after 10 s, the speed is reduced again. The amount of speed reduction depends on how often the alarm repeats. If the oH alarm disappears while the drive is operating at a reduced speed, the drive will switch to the previous speed in 10 s increments until reaching base frequency. *Figure 5.109* explains the operation with reduced speed during an oH alarm. A digital output programmed for 4D is switched when the oH alarm is still active after ten reduction cycles.

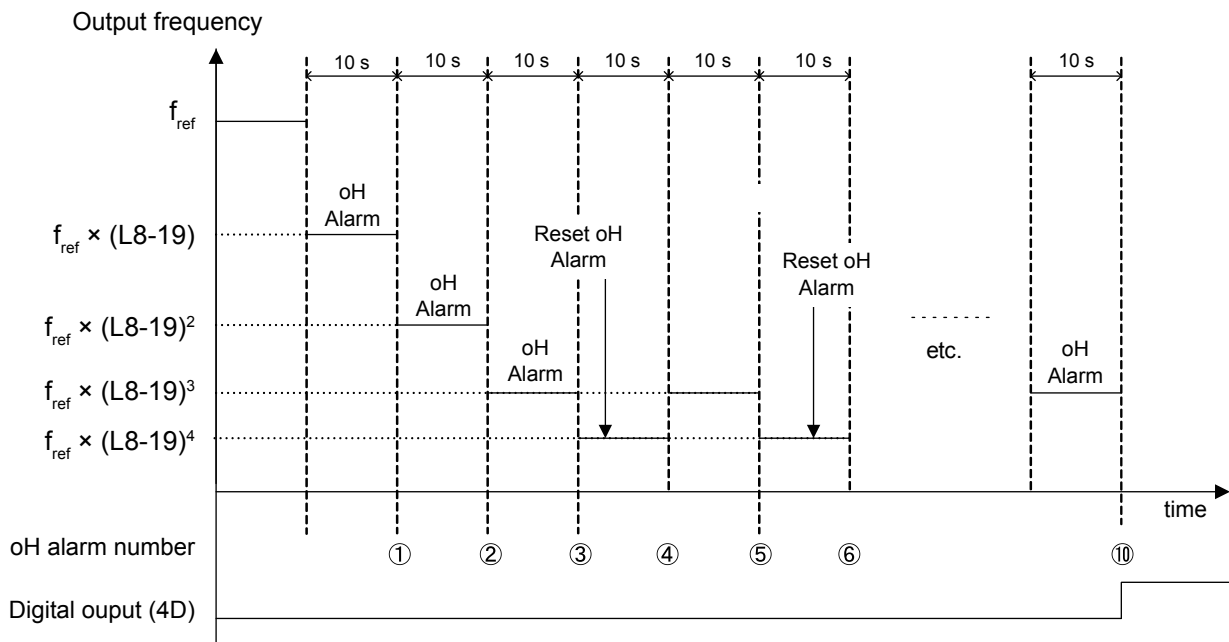

Figure 5.109 Output Frequency Reduction During Overheat Alarm

■ L8-19: Frequency Reduction Rate during Overheat Pre-Alarm

Specifies the output frequency reduction when L8-03 is set to 4 and an oH alarm is present. Set as a factor of the maximum output frequency.

5.8 L: Protection Functions

No.	Name	Setting Range	Default
L8-19	Frequency Reduction Rate During Overheat Pre-Alarm	0.1 to 0.9	0.8

■ L8-05: Input Phase Loss Protection Selection

Enables or disables the input phase loss detection.

No.	Name	Setting Range	Default
L8-05	Input Phase Loss Protection Selection	0, 1	1

Setting 0: Disabled

Setting 1: Enabled

Enables input phase loss detection. Since measuring the DC bus ripple detects input phase loss, a power supply voltage imbalance or main circuit capacitor deterioration may also trigger a phase loss fault (PF).

Detection is disabled if:

- The drive is decelerating.
- No Run command is active.
- Output current is less than or equal to 30% of the drive rated current.

■ L8-07: Output Phase Loss Protection Selection

Enables or disables the output phase loss detection triggered when the output current falls below 5% of the drive rated current.

- Note:**
1. Output phase loss detection can mistakenly be triggered if the motor rated current is very small compared to the drive rating. Disable this parameter in such cases.
 2. Output phase loss detection is not possible when the drive is running a PM motor with light load.

No.	Name	Setting Range	Default
L8-07	Output Phase Loss Protection Selection	0 to 2	1

Setting 0: Disabled

Setting 1: Fault when One Phase Is Lost

An output phase loss fault (LF) is triggered when one output phase is lost. The output shuts off and the motor coasts to stop.

Setting 2: Fault when Two Phases Are Lost

An output phase loss fault (LF) is triggered when two or more output phases are lost. The output shuts off and the motor coasts to stop.

■ L8-09: Output Ground Fault Detection Selection

Enables or disables the output ground fault detection.

No.	Name	Setting Range	Default
L8-09	Output Ground Fault Detection Selection	0, 1	1

Setting 0: Disabled

Ground faults are not detected.

Setting 1: Enabled

A ground fault (GF) is triggered when high leakage current or a ground short circuit occurs in one or two output phases.

■ L8-10: Heatsink Cooling Fan Operation Selection

Selects the heatsink cooling fan operation.

No.	Name	Setting Range	Default
L8-10	Heatsink Cooling Fan Operation Selection	0, 1	0

Setting 0: Run with timer

The fan is switched on when a Run command is active and switched off with the delay set to parameter L8-11 after releasing the Run command. This setting extends the fan lifetime.

Setting 1: Run always

The fan runs when power is supplied to the drive.

■ L8-11: Heatsink Cooling Fan Off-Delay Time

Sets the cooling fan switch off-delay time if parameter L8-10 is set to 0.

No.	Name	Setting Range	Default
L8-11	Heatsink Cooling Fan Off-Delay Time	0 to 300 s	60 s

■ L8-12: Ambient Temperature Setting

Automatically adapts the drive rated current to safe values when used with parameter L8-35. This eliminates the need to reduce the drive rated current when the temperature where the drive is mounted is above the specified values. *Refer to Temperature Derating on page 486* for details.

No.	Name	Setting Range	Default
L8-12	Ambient Temperature Setting	-10 to 50 °C	40 °C

■ L8-15: oL2 Characteristics Selection at Low Speeds

Selects whether the drive overload capability (oL fault detection level) is reduced at low speeds to prevent premature output transistor failures.

Note: Contact Yaskawa for consultation before disabling this function. Disabling this function may shorten the operating life of the power transistors.

No.	Name	Setting Range	Default
L8-15	oL2 Characteristics Selection at Low Speed	0, 1	1

Setting 0: Protection Disabled at Low Speed

The overload protection level is not reduced. Frequently operating the drive with high output current at low speed can lead to premature drive faults.

Setting 1: Protection Enabled at Low Speed

The overload protection level (oL2 fault detection level) is automatically reduced at speeds below 6 Hz. At zero speed, the overload is derated by 50%.

■ L8-18: Software Current Limit Selection

Enables or disables the Software Current Limit (CLA) protection function to prevent main circuit transistor failures caused by high current.

Note: Do not change this setting unless absolutely necessary. Leave the Software CLA enabled for proper drive protection and operation.

No.	Name	Setting Range	Default
L8-18	Software Current Limit Selection	0, 1	0

Setting 0: Software CLA Disabled

The drive may trip on an oC fault if the load is too heavy or the acceleration is too short.

Setting 1: Software CLA Enabled

When the Software CLA current level is reached, the drive reduces the output voltage to reduce the current. Normal operation continues when the current level drops below the Software CLA level.

■ L8-27: Overcurrent Detection Gain

Note: PM motor control modes are not available on 600 V class drives, models 5A□□□□.

Adjusts the overcurrent detection level in OLV/PM, AOLV/PM, or CLV/PM. A setting of 100% is equal to the motor rated current. When the drive rated current is considerably higher than the motor rated current, use this parameter to decrease the overcurrent level and prevent motor demagnetization from high current.

Overcurrent detection uses the lower value between the overcurrent level for the drive and the motor rated current multiplied by L8-27.

No.	Name	Setting Range	Default
L8-27	Overcurrent Detection Gain	0.0 to 400.0% </>	300.0%

</> The setting range is 0.0 to 300.0% for models 4A0930 and 4A1200.

5.8 L: Protection Functions

■ L8-29: Current Unbalance Detection (LF2)

Note: PM motor control modes are not available on 600 V class drives, models 5A□□□□.

Enables or disables output current unbalance detection in OLV/PM, AOLV/PM, or CLV/PM. Current unbalance can heat a PM motor and demagnetize the magnets. The current unbalance detection function monitors output current and triggers the LF2 fault to prevent such motor damage.

No.	Name	Setting Range	Default
L8-29	Current Unbalance Detection (LF2)	0, 1	1

Setting 0: Disabled

No current unbalance protection is provided to the motor.

Setting 1: Enabled

The LF2 fault is triggered if an output current unbalance is detected. Drive output shuts off and the motor coasts to stop.

■ L8-32: Main Contactor and Cooling Fan Power Supply Failure Selection

Determines drive operation when a FAn fault occurs.

No.	Name	Setting Range	Default
L8-32	Main Contactor and Cooling Fan Power Supply Failure Selection	0 to 4	1

Setting 0: Ramp to stop

The drive stops the motor using the deceleration time set in parameter C1-02.

Setting 1: Coast to stop

The drive output is switched off and the motor coasts to a stop.

Setting 2: Fast stop

The drive stops the motor using the Fast stop time set in parameter C1-09.

Setting 3: Alarm only

The operation is continued and a FAn alarm is displayed on the digital operator.

Setting 4: Operation with reduced speed

The operation is continued, but the speed is reduced to the level set in parameter L8-19.

Note: “FAn” is detected as an error when Settings 0 or 2 are selected; it is detected as an alarm when Settings 3 or 4 are selected.

■ L8-35: Installation Method Selection

Selects the type of installation for the drive and changes the drive overload (oL2) limits accordingly. *Refer to Temperature Derating on page 486* for details.

- Note:**
1. Initialization does not reset this parameter.
 2. The value is preset to the appropriate value when the drive is shipped. Change the value only when using Side-by-Side installation or when mounting a standard drive with the heatsink outside the cabinet.

No.	Name	Setting Range	Default
L8-35	Installation Method Selection	0 to 3	<1>

<1> Default setting is determined by drive model.

Setting 2: Model code 2A0004 to 2A0211, 4A0002 to 4A0165, and 5A0003 to 5A0242

Setting 0: Model code 2A0250 to 2A0415 and 4A0208 to 4A1200.

Setting 0: IP00/Open-Chassis enclosure

For an Open Type enclosure drive installed with at a minimum of 30 mm space to the next drive or a cabinet wall.

Setting 1: Side-by-Side mounting

For drives mounted according to Yaskawa Side-by-Side specifications (requires 2 mm between drives).

Setting 2: IP20/NEMA Type 1 enclosure

For drives compliant with IP20/NEMA Type 1 enclosure specifications.

Setting 3: Finless drive or external heatsink Installation

For finless drives or a standard drive mounted with the heatsink outside the cabinet or enclosure panel.

■ L8-38: Carrier Frequency Reduction Selection

Selects the operation of the carrier frequency reduction function. Reduces the carrier frequency when the output current exceeds a certain level. This temporarily increases the overload capability (oL2 detection), allowing the drive to run through transient load peaks without tripping.

Note: This function cannot be used in AOLV/PM.

No.	Name	Setting Range	Default
L8-38	Carrier Frequency Reduction Selection	0 to 2	Determined by A1-02, C6-01 and o2-04

Setting 0: Disabled

No carrier frequency reduction at high current.

Setting 1: Enabled for output frequencies below 6 Hz

The carrier frequency is reduced at speeds below 6 Hz when the current exceeds 100% of the drive rated current. The drive returns to the normal carrier frequency when the current falls below 88% or the output frequency exceeds 7 Hz.

Setting 2: Enabled for entire frequency range

The carrier frequency is reduced at the following speeds:

- Below 6 Hz when the current exceeds 100% of the drive rated current.
- Above 7 Hz when the current exceeds 112% of the drive rated current.

The drive uses the delay time set in parameter L8-40 and a hysteresis of 12% when switching the carrier frequency back to the set value.

■ L8-40: Carrier Frequency Reduction Off-Delay Time

Sets a hold time before returning to the original carrier frequency setting after the carrier frequency has been temporarily derated as determined by L8-38. The carrier frequency reduction function is disabled when this value is 0.00 s.

No.	Name	Setting Range	Default
L8-40	Carrier Frequency Reduction Off-Delay Time	0.00 to 2.00 s	Determined by A1-02

■ L8-41: High Current Alarm Selection

Triggers a high current alarm (HCA) when the output current exceeds 150% of the drive rated current.

No.	Name	Setting Range	Default
L8-41	High Current Alarm Selection	0, 1	0

Setting 0: Disabled

No alarm is detected.

Setting 1: Enabled

An alarm is triggered when the output current exceeds 150% of the drive rated current. A digital output set for an alarm (H2-□□ = 10) will close.

■ L8-55: Internal Braking Transistor Protection

Enables or disables protection for the internal braking transistor.

Note: This parameter is not available in models 4A0930 and 4A1200.

No.	Name	Setting Range	Default
L8-55	Internal Braking Transistor Protection	0, 1	0

Setting 0: Disabled

Disable braking transistor protection when not using the internal braking transistor, including the following instances:

- When using a regen converter such as DC5.
- When using a regen unit such as RC5.
- When using external braking transistor options like CDBR units.
- When using the drive in common DC bus applications and the internal braking unit is not installed.

5.8 L: Protection Functions

Enabling L8-55 under such conditions can incorrectly trigger a braking transistor fault (rr).

Setting 1: Enabled

Enable L8-55 when connecting a braking resistor or a braking resistor unit to the drive built-in braking transistor. Models 2A0004 to 2A0138, 4A0002 to 4A0072, and 5A0003 to 5A0052 come with a built-in braking transistor.

■ L8-78: Power Unit Output Phase Loss Protection

Protects the power unit from phase loss.

Note: This parameter is only available in models 4A0930 and 4A1200.

No.	Name	Setting Range	Default
L8-78	Power Unit Output Phase Loss Protection	0, 1	1

Setting 0: Disabled

Setting 1: Enabled

■ L8-93: LSo Detection Time at Low Speed

Sets the amount of time until baseblock is executed after LSo has been detected at low speed.

A setting of 0.0 s disables this parameter.

No.	Name	Setting Range	Default
L8-93	LSo Detection Time at Low Speed	0.0 to 10.0 s	1.0 s

■ L8-94: LSo Detection Level at Low Speed

Determines the detection level of Sto at low speed. Set as a percentage of the maximum frequency (E1-04).

No.	Name	Setting Range	Default
L8-94	LSo Detection Level at Low Speed	0 to 10%	3%

■ L8-95: Average LSo Frequency at Low Speed

Sets the average number of times LSo can occur at low speed.

No.	Name	Setting Range	Default
L8-95	Average LSo Frequency at Low Speed	1 to 50 times	10 times

5.9 n: Special Adjustments

These parameters control a variety of specialized adjustments and functions, including Hunting Prevention, AFR Control, High Slip Braking, resistance between motor lines, and PM motor control functions.

◆ n1: Hunting Prevention

Hunting Prevention prevents the drive from hunting as a result of low inertia and operating with light load. Hunting often occurs with a high carrier frequency and an output frequency below 30 Hz.

■ n1-01: Hunting Prevention Selection

Enables or disables the Hunting Prevention function.

Note: This function is available only when using V/f Control. Disable Hunting Prevention when drive response is more important than suppressing motor oscillation. This function may be disabled without problems in applications with high inertia loads or relatively heavy loads.

No.	Name	Setting Range	Default
n1-01	Hunting Prevention Selection	0, 1	1

Setting 0: Disabled

Setting 1: Enabled

■ n1-02: Hunting Prevention Gain Setting

Sets the gain for the Hunting Prevention Function.

No.	Name	Setting Range	Default
n1-02	Hunting Prevention Gain Setting	0.00 to 2.50	1.00

Although this parameter rarely needs to be changed, it may require adjustment in the following situations:

- If the motor vibrates while lightly loaded and n1-01 = 1, increase the gain by 0.1 until vibration ceases.
- If the motor stalls while n1-01 = 1, decrease the gain by 0.1 until the stalling ceases.

■ n1-03: Hunting Prevention Time Constant

Determines the responsiveness of the Hunting Prevention function (affects the primary delay time for Hunting Prevention).

No.	Name	Setting Range	Default
n1-03	Hunting Prevention Time Constant	0 to 500 ms	Determined by o2-04

Although this parameter rarely needs to be changed, it may require adjustment in the following situations:

- Increase this value for applications with a large load inertia. A higher setting leads to slower response, which can result in oscillation at lower frequencies.
- Lower this setting if oscillation occurs at low speed.

■ n1-05: Hunting Prevention Gain while in Reverse

This parameter functions the same as n1-02, except it is used when rotating in reverse. See the explanation for n1-02.

Note: n1-02 is enabled for forward and reverse operation when n1-05 = 0.0 ms.

No.	Name	Setting Range	Default
n1-05	Hunting Prevention Gain while in Reverse	0.00 to 2.50	0.00

◆ n2: Speed Feedback Detection Control (AFR) Tuning

These parameters help achieve speed stability when a load is suddenly applied or removed.

Note: Properly set all motor parameters or perform Auto-Tuning before making changes to the AFR parameters.

■ n2-01: AFR Gain

Sets the internal speed feedback detection control gain in the AFR.

No.	Name	Setting Range	Default
n2-01	AFR Gain	0.00 to 10.00	1.00

Although this parameter rarely needs to be changed, it may require adjustment in the following situations:

- If hunting occurs, increase the setting value in steps of 0.05 while checking the response.
- If response is low, decrease the setting value in steps of 0.05 while checking the response.

■ n2-02, n2-03: AFR Time Constant 1, 2

Parameter n2-02 sets the time constant normally used by AFR.

Parameter n2-03 sets the time constant during Speed Search or regenerative operation.

No.	Name	Setting Range	Default
n2-02	AFR Time Constant 1	0 to 2000 ms	50 ms
n2-03	AFR Time Constant 2	0 to 2000 ms	750 ms

Note: Setting parameter n2-02 higher than n2-03 will trigger an oPE08 error.

Although these parameters rarely need to be changed, they may require adjustment in the following situations:

- If hunting occurs, increase n2-02. If response is low, decrease it.
- Increase n2-03 if overvoltage occurs with high inertia loads at the end of acceleration or with sudden load changes.
- If setting n2-02 to a higher value, increase C4-02 (Torque Compensation Delay Time Constant 1) proportionally.
- If setting n2-03 to a higher value, increase C4-06 (Torque Compensation Delay Time Constant 2) proportionally.

◆ n3: High Slip Braking (HSB) and Overexcitation Braking

■ High Slip Braking (V/f)

HSB works in V/f Control only and decreases the stopping time compared to normal deceleration without using dynamic braking options. HSB reduces the output frequency in large steps to stop the motor and produce a high slip, which dissipates the regenerative energy created from decelerating the load in the motor windings. Due to the increased temperature of the motor windings, do not use HSB to frequently stop the motor. The duty cycle should be around 5% or lower.

Notes on using High Slip Braking

- The set deceleration time is ignored during HSB. Use Overexcitation Deceleration 1 (L3-04 = 4) or a dynamic braking option to stop the motor within a specified time.
- Braking time varies based on the load inertia and motor characteristics.
- Enabling HSB and KEB Ride-Thru simultaneously will trigger an oPE03 error.
- HSB must be triggered by a digital input set to H1-□□ = 68. After the HSB command is given, the drive will not restart until the motor is completely stopped and the Run command is cycled.
- Use parameters n3-01 through n3-04 to adjust HSB.

■ n3-01: High Slip Braking Deceleration Frequency Width

Sets the step width for frequency reduction during HSB. Increase n3-01 if DC bus overvoltage (ov) occurs during HSB.

No.	Name	Setting Range	Default
n3-01	High Slip Braking Deceleration Frequency Width	1 to 20%	5%

■ n3-02: High Slip Braking Current Limit

Sets the maximum current to be output during an HSB stop as a percentage of motor rated current (E2-01). Reducing the current limit increases the deceleration time. This value must not exceed the drive overload capacity.

- Lower this setting if overvoltage occurs during HSB.
- Lower this setting if motor current is too high during HSB. High current can damage the motor due to overheat.
- The default setting is 150% when the drive is set for Heavy Duty, and 120% when the drive is set for Normal Duty.

No.	Name	Setting Range	Default
n3-02	High Slip Braking Current Limit	100 to 200%	Determined by C6-01 and L8-38

■ n3-03: High Slip Braking Dwell Time at Stop

When the motor reaches a relatively low speed at the end of HSB, the output frequency is kept at the minimum output frequency set to E1-09 for the time set to n3-03. Increase this time if the inertia is very high and the motor coasts after HSB is complete.

No.	Name	Setting Range	Default
n3-03	High Slip Braking Dwell Time at Stop	0.0 to 10.0 s	1.0 s

■ n3-04: High Slip Braking Overload Time

Sets the time required for an HSB overload fault (oL7) to occur when the drive output frequency does not change during an HSB stop due to excessive load inertia or the load rotating the motor. To protect the motor from overheat, the drive trips with an oL7 fault if these conditions last longer than the time set in n3-04.

No.	Name	Setting Range	Default
n3-04	High Slip Braking Overload Time	30 to 1200 s	40 s

■ Overexcitation Deceleration (Induction Motors)

Increases the flux during deceleration and allows shorter deceleration time settings without the use of a braking resistor. Enabled by setting L3-04 to 4 or 5. [Refer to L3-04: Stall Prevention Selection during Deceleration on page 295.](#)

Notes on Overexcitation Deceleration

- Frequently applying Overexcitation Deceleration raises the motor temperature because regenerative energy is mainly dissipated as heat in the motor. In cases where frequent application is required, make sure the motor temperature does not exceed the maximum allowable value or consider using a braking resistor option in lieu of Overexcitation Deceleration.
- During Overexcitation Deceleration 2, Hunting Prevention in V/f Control and torque limits in OLV Control are disabled.
- Do not use Overexcitation Deceleration in combination with a braking resistor option.
- Overexcitation Deceleration can be used in OLV and CLV, but it lowers the accuracy of Torque Control and braking efficiency. It can be most efficiently used in a V/f Control.
- Overexcitation Deceleration cannot be used with PM motors.

Parameter Adjustments

- Use parameters n3-13 through n3-23 to adjust Overexcitation Deceleration.
- When repetitive or long Overexcitation Deceleration causes motor overheat, lower the overexcitation gain (n3-13) and reduce the overslip suppression current level (n3-21).
- During Overexcitation Deceleration 1 (L3-04 = 4), the drive decelerates at the active deceleration time (C1-02, C1-04, C1-06, or C1-08). Set this time so no overvoltage (ov) fault occurs.
- During Overexcitation Deceleration 2 (L3-04 = 5), the drive decelerates using the active deceleration time while adjusting the deceleration rate to keep the DC bus voltage at the level set to L3-17. The actual stopping time will be longer or shorter than the set deceleration time depending on the motor characteristics and the load inertia. Increase the deceleration time if overvoltage occurs (ov).
- Entering a Run command during Overexcitation Deceleration cancels overexcitation operation and the drive reaccelerates to the specified speed.

5.9 n: Special Adjustments

■ n3-13: Overexcitation Deceleration Gain

Multiplies a gain to the V/f pattern output value during Overexcitation Deceleration to determine the level of overexcitation. The drive returns to the normal V/f value after the motor has stopped or when it is accelerating to the frequency reference.

No.	Name	Setting Range	Default
n3-13	Overexcitation Deceleration Gain	1.00 to 1.40	1.10

The optimum setting for n3-13 depends on the motor flux saturation characteristics.

- Gradually increase the gain to 1.25 to 1.30 to improve the braking power of Overexcitation Deceleration.
- Lower n3-13 when flux saturation characteristics cause overcurrent. A high setting sometimes causes overcurrent (oC), motor overload (oL1), or drive overload (oL2). Lowering n3-21 can also help remedy these problems.

■ n3-14: High Frequency Injection during Overexcitation Deceleration

Enables High Frequency Injection while Overexcitation Deceleration is executed. Injecting high frequency into the motor increases loss and shortens deceleration time. This function tends to increase audible noise from the motor, and may not be desirable in environments where motor noise is a concern.

No.	Name	Setting Range	Default
n3-14	High Frequency Injection During Overexcitation Deceleration	0, 1	0

Setting 0: Disabled

Setting 1: Enabled

■ n3-21: High Slip Suppression Current Level

If the motor current exceeds the value set to n3-21 during Overexcitation Deceleration due to flux saturation, the drive automatically reduces the overexcitation gain. Parameter n3-21 is set as a percentage of the drive rated current.

Set this parameter to a relatively low value to optimize deceleration. If overcurrent, oL1, or oL2 occur during Overexcitation Deceleration, reduce the high slip suppression current level.

No.	Name	Setting Range	Default
n3-21	High Slip Suppression Current Level	0 to 150%	100%

■ n3-23: Overexcitation Operation Selection

Limits the Overexcitation Deceleration operation selected in parameter L3-04 to forward only or reverse only.

No.	Name	Setting Range	Default
n3-23	Overexcitation Operation Selection	0 to 2	0

Setting 0: Overexcitation Operation as Selected in L3-04 in Forward and Reverse Direction

Setting 1: Overexcitation Operation as Selected in L3-04 in Forward Direction Only

Setting 2: Overexcitation Operation as Selected in L3-04 in Reverse Direction Only

◆ n5: Feed Forward Control

Note: PM motor control modes are not available on 600 V class drives, models 5A□□□□.

Enabling Feed Forward improves the responsiveness of the drive to speed reference changes in applications where a high speed control proportional gain setting (ASR gain, C5-01, C5-03) would lead to problems with overshoot, undershoot, or oscillation. **Figure 5.110** gives an example of overshoot reduction by Feed Forward. Parameters related to this function and the function principle are illustrated in **Figure 5.111**. Feed Forward can only be used in CLV, CLV/PM, or AOLV/PM (A1-02 = 4, 6, or 7).

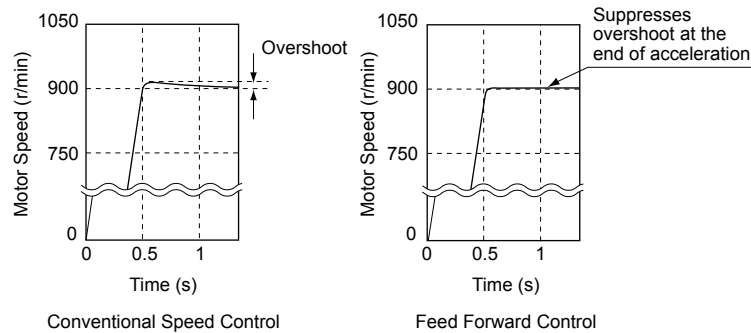

Figure 5.110 Overshoot Suppression by Feed Forward Control

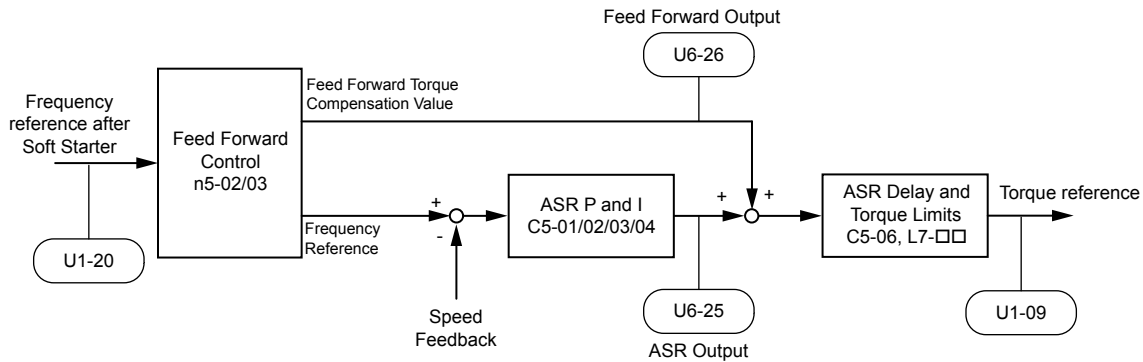

Figure 5.111 Feed Forward Control

- Note:**
1. Feed Forward can only be used in CLV, AOLV/PM, and CLV/PM control modes.
 2. Prior to using Feed Forward, always perform Auto-Tuning or manually enter the correct motor data. Perform ASR Auto-Tuning to set the speed loop gain (C5-01), or adjust it manually. Fine-tune the other speed control loop parameters (C5-□□) if required.
 3. If not restricted by the application, use Inertia Auto Tuning (T1-01 = 8) to automatically optimize Feed Forward parameters. If Inertia Auto Tuning cannot be performed, manually set parameters related to Feed Forward.

■ n5-01: Feed Forward Control Selection

Enables and disables the Feed Forward function.

No.	Name	Setting Range	Default
n5-01	Feed Forward Control Selection	0, 1	0

Setting 0: Disabled

Setting 1: Enabled

■ n5-02: Motor Acceleration Time

Sets the time required to accelerate the motor from a full stop to the rated speed at the rated torque.

No.	Parameter Name	Setting Range	Default
n5-02	Motor Acceleration Time	0.001 to 10.000 s	Determined by C6-01, E5-01 and o2-04

5.9 n: Special Adjustments

Set this value automatically with Inertia Auto-Tuning. If Inertia Auto-Tuning cannot be performed, use one of the following methods to determine the setting value for this parameter.

Calculation

The motor acceleration time can be calculated by one of the following formulas:

$n5-02 = \frac{\pi \cdot J_{\text{Motor}} \cdot n_{\text{rated}}}{30 \cdot T_{\text{rated}}}$	<p>Where:</p> <ul style="list-style-type: none"> • J_{Motor} is the motor inertia in kgm^2. • n_{rated} is the rated speed of the motor in r/min. • T_{rated} is the rated torque of the motor in $\text{N}\cdot\text{m}$.
---	--

OR

$n5-02 = \frac{4 \cdot \pi \cdot J_{\text{Motor}} \cdot f_{\text{rated}}}{p \cdot T_{\text{rated}}}$	<p>Where:</p> <ul style="list-style-type: none"> • J_{Motor} is the motor inertia in kgm^2. • f_{rated} is the rated frequency of the motor in Hz. • p is the number of motor poles (not pole pairs). • T_{rated} is the rated torque of the motor in $\text{N}\cdot\text{m}$.
--	--

Measuring Acceleration Time

Take the following steps when measuring the motor acceleration time:

1. Select the control mode; CLV (A1-02 = 3), AOLV/PM (A1-02 = 6), or CLV/PM (A1-02 = 7).
2. Decouple motor and load.
3. Perform Auto-Tuning or manually enter the correct motor data.
4. Properly set up the speed loop (ASR).
5. Set the acceleration time to zero.
6. Set the forward torque limit in parameter L7-01 to 100%.
7. Set the frequency reference equal to the motor rated speed.
8. While monitoring the motor speed in U1-05, start the motor in the forward direction and measure the time it takes to reach the rated speed.
9. Reverse the parameter settings above and set the measured time to parameter n5-02.

■ n5-03: Feed Forward Control Gain

Sets the inertia ratio of the load connected to the motor. This value can be set automatically by Inertia Auto-Tuning.

No.	Parameter Name	Setting Range	Default
n5-03	Feed Forward Control Gain	0.00 to 100.00	1.00

Set this value automatically with Inertia Auto-Tuning. If Inertia Auto Tuning cannot be performed, determine the value for parameter n5-03 using the following steps:

1. Select the control mode; CLV (A1-02 = 3), AOLV/PM (A1-02 = 6), or CLV/PM (A1-02 = 7).
2. Set parameter n5-02 correctly.
3. Couple motor and load.
4. Set the acceleration time in C1-01 to 0.
5. Set the torque limits in the L7-□□ parameters to a value that will easily be reached during the test ($T_{\text{Lim_Test}}$).
6. Set the frequency reference equal to a value in the upper speed range of the machine ($f_{\text{ref_Test}}$).
7. While monitoring the motor speed in U1-05, start the motor in the forward direction and measure the time it takes to reach the reference speed (t_{accel}).
8. Reverse the parameter settings above and calculate the set value for parameter n5-03 using the formula below.

$n5-03 = \frac{t_{\text{accel}} \cdot T_{\text{Lim_Test}} \cdot f_{\text{rated}}}{n5-02 \cdot f_{\text{ref_Test}} \cdot 100} - 1$	<p>Where:</p> <ul style="list-style-type: none"> • t_{accel} is the measured acceleration time in s. • f_{rated} is the rated frequency of the motor in Hz. • $T_{\text{Lim_Test}}$ is torque limit setting during the test (%). • $f_{\text{ref_Test}}$ is the frequency reference during the test in Hz.
---	--

◆ n6: Online Tuning

Online Tuning prevents loss from insufficient torque and diminished speed control accuracy due to fluctuating motor temperature.

■ n6-01: Online Tuning Selection

Selects the type of motor data Online Tuning uses for OLV control.

No.	Name	Setting Range	Default
n6-01	Online Tuning Selection	0 to 2	0

Setting 0: Disabled

Setting 1: Line-to-line resistance tuning

This setting enables line-to-line resistance online tuning. This procedure is effective for speed values up to 6 Hz and improves the overload capacity in the low speed range by adjusting the value set for the motor resistance.

Setting 2: Voltage correction

The drive adjusts the output voltage during run to improve overload tolerance and minimize the effects of high temperatures on speed accuracy.

Note: This setting can only be selected when the Energy Saving function is disabled (b8-01 = 0).

■ n6-05: Online Tuning Gain

Sets the compensation gain for the voltage correction in the Online Tuning function (n6-01 = 2).

Although this parameter rarely needs to be changed, increase the set value in steps of 0.1 if an overload fault occurs during voltage correction

No.	Name	Setting Range	Default
n6-05	Online Tuning Gain	0.1 to 50.0	1.0

◆ n8: PM Motor Control Tuning

Note: PM motor control modes are not available on 600 V class drives, models 5A□□□□.

These parameters adjust the control performance in the vector control modes for permanent magnet motors.

■ n8-01: Initial Rotor Position Estimation Current

Sets the current used for initial rotor position estimation as a percentage of the motor rated current (E5-03). If the motor nameplate lists an “SI” value, that value should be entered here. There is normally no need to change this parameter from the default value.

- Note:**
1. PM motor control modes are not available on 600 V class drives, models 5A□□□□.
 2. This parameter is only available in AOLV/PM or CLV/PM.

No.	Name	Setting Range	Default
n8-01	Initial Rotor Position Estimation Current	0 to 100%	50%

■ n8-02: Pole Attraction Current

Sets the current that is applied to pull the rotor into position after the initial rotor position estimations are complete. The value is set as a percentage of the motor rated current. Increase this setting to increase the starting torque.

- Note:**
1. PM motor control modes are not available on 600 V class drives, models 5A□□□□.
 2. This parameter is only available in AOLV/PM or CLV/PM.

No.	Name	Setting Range	Default
n8-02	Pole Attraction Current	0 to 150%	80%

■ n8-35: Initial Rotor Position Detection Selection

Selects how the rotor position is detected at start.

- Note:**
1. PM motor control modes are not available on 600 V class drives, models 5A□□□□.
 2. In CLV/PM, the drive performs a magnetic pole search the first time it starts the motor. After that, rotor position is calculated from the PG encoder signal and saved until the drive is switched off. Parameter n8-35 determines how this initial pole search operates.

5.9 n: Special Adjustments

- High Frequency Injection and pulse injection for rotor position detection (n8-35 = 1 or 2) can be used with IPM motors only. When using an SPM motor, select the pull in method to find the initial position of the rotor (n8-35 = 0).
- This parameter is only available in AOLV/PM or CLV/PM.

No.	Name	Setting Range	Default
n8-35	Initial Rotor Position Detection Selection	0 to 2	1

Setting 0: Pull in

Starts the rotor using pull-in current.

Setting 1: High Frequency Injection

High frequency is injected to detect the rotor position. Some noise may be generated from the motor at start.

Setting 2: Pulse injection

A pulse signal is injected into the motor to detect the rotor position.

■ n8-45: Speed Feedback Detection Control Gain

Sets the gain for internal speed feedback detection control. Although this parameter rarely needs to be changed, adjustment may be necessary under the following conditions:

- Increase this setting if motor oscillation or hunting occurs.
- Decrease this setting in increments of 0.05 to decrease drive responsiveness.

- Note:**
- PM motor control modes are not available on 600 V class drives, models 5A□□□□.
 - This parameter is only available in OLV/PM.

No.	Name	Setting Range	Default
n8-45	Speed Feedback Detection Control Gain	0.00 to 10.00	0.80

■ n8-47: Pull-In Current Compensation Time Constant

Sets the time constant for pull-in current to match the actual current.

Although this setting rarely needs to be changed, adjustment may be necessary under the following conditions:

- Increase this setting when it takes too long for the reference value of the pull-in current to match the target value.
- Decrease this setting if motor oscillation occurs.

- Note:**
- PM motor control modes are not available on 600 V class drives, models 5A□□□□.
 - This parameter is only available in OLV/PM.

No.	Name	Setting Range	Default
n8-47	Pull-In Current Compensation Time Constant	0.0 to 100.0 s	5.0 s

■ n8-48: Pull-In Current

Sets the d-Axis current during no-load operation at a constant speed. Set as a percentage of the motor rated current.

- Increase this setting when hunting occurs or the motor speed is unstable while running at a constant speed.
- Slightly reduce this value if there is too much current when driving a light load at a constant speed.

- Note:**
- PM motor control modes are not available on 600 V class drives, models 5A□□□□.
 - This parameter is only available in OLV/PM.

No.	Name	Setting Range	Default
n8-48	Pull-In Current	20 to 200%	30%

■ n8-49: d-Axis Current for High Efficiency Control

Sets the d-Axis current reference when running with high load at constant speed. When using an IPM motor, this parameter uses the reluctance torque to increase the efficiency and reduce energy consumption. Set this parameter to 0 when using an SPM motor.

Although this setting rarely needs to be changed, adjustment may be necessary under the following conditions:

- Lower the setting if motor operation is unstable when driving heavy loads.
- If motor parameters (E5-□□) have been changed, this value will be reset to 0 and will require readjustment.

- Note:**
- PM motor control modes are not available on 600 V class drives, models 5A□□□□.
 - This parameter is only available in OLV/PM.

No.	Name	Setting Range	Default
n8-49	d Axis Current for High Efficiency Control	-200.0 to 0.0%	Determined by E5-01

■ n8-51: Acceleration/Deceleration Pull-In Current

Sets the pull-in current during acceleration and deceleration as a percentage of the motor rated current (E5-03).

Adjustment may be necessary under the following conditions:

- Increase this setting when a large amount of starting torque is required.
- Lower this setting if there is excessive current during acceleration.

- Note:**
1. PM motor control modes are not available on 600 V class drives, models 5A□□□□.
 2. This parameter is only available in OLV/PM.

No.	Name	Setting Range	Default
n8-51	Acceleration/Deceleration Pull-In Current	0 to 200%	50%

■ n8-54: Voltage Error Compensation Time Constant

Sets the time constant for voltage error compensation.

Adjustment may be necessary under the following conditions:

- Adjust the value when hunting occurs at low speed.
- Increase the value in steps of 0.1 when hunting occurs with sudden load changes. Set n8-51 to 0 to disable the compensation if increasing n8-54 does not help.
- Increase the value when oscillations occur at start.

- Note:**
1. PM motor control modes are not available on 600 V class drives, models 5A□□□□.
 2. This parameter is only available in OLV/PM.

No.	Name	Setting Range	Default
n8-54	Voltage Error Compensation Time Constant	0.00 to 10.00	1.00

■ n8-55: Load Inertia

Sets the ratio between motor inertia and the inertia of the connected machinery. If this value is set too low, the motor may not start very smoothly and trigger an STo (Motor Step-Out) fault.

Increase this setting for large inertia loads or to improve speed control response. A high setting with low inertia load may cause oscillation.

- Note:**
1. PM motor control modes are not available on 600 V class drives, models 5A□□□□.
 2. This parameter is only available in OLV/PM.

No.	Name	Setting Range	Default
n8-55	Load Inertia	0 to 3	0

Setting 0: Below 1:10

The inertia ratio between the motor and the load is lower than 1:10.

Setting 1: Between 1:10 and 1:30

The inertia ratio between the motor and the load is between 1:10 and 1:30. Set n8-55 to 1 if an STo fault occurs as a result of impact load or sudden acceleration/deceleration when n8-55 = 0.

Setting 2: Between 1:30 and 1:50

The inertia ratio between the motor and the load is between 1:30 and 1:50. Set n8-55 to 2 if an STo fault occurs as a result of impact load or sudden acceleration/deceleration when n8-55 = 1.

Setting 3: Beyond 1:50

The inertia ratio between the motor and the load is higher than 1:50. Set n8-55 to 3 if an STo fault occurs as a result of impact load or sudden acceleration/deceleration when n8-55 = 2.

■ n8-57: High Frequency Injection

Injects a high frequency into the motor to detect motor speed.

- Note:**
1. PM motor control modes are not available on 600 V class drives, models 5A□□□□.

5.9 n: Special Adjustments

2. This parameter is only available in AOLV/PM.

No.	Name	Setting Range	Default
n8-57	High Frequency Injection	0, 1	0

Setting 0: Disabled

Disable n8-57 with SPM motors. The speed control range will be limited to approximately 1:20.

Setting 1: Enabled

Enable n8-57 with IPM motors. This allows precise speed detection in a speed control range of approximately 1:100.

- Note:**
1. This function generates some audible noise in the motor up to a certain speed.
 2. Set E1-09 to 0.0 when using zero speed control.

■ n8-62: Output Voltage Limit

Sets the output voltage limit to prevent voltage saturation. Do not set this value higher than the actual input voltage.

- Note:**
1. PM motor control modes are not available on 600 V class drives, models 5A□□□□.
 2. This parameter is only available in OLV/PM, AOLV/PM, and CLV/PM.

No.	Name	Setting Range	Default
n8-62	Output Voltage Limit	0.0 to 230.0 Vac </>	200 Vac </>

</> Values shown are specific to 200 V class drives. Double value for 400 V class drives.

■ n8-65: Speed Feedback Detection Control Gain during ov Suppression

Sets the gain for internal speed feedback detection control when overvoltage suppression is active. Although this setting rarely needs to be changed, adjustment may be necessary under the following conditions:

- Increase this setting if motor oscillation or hunting occurs when ov suppression is active.
- Decrease this setting in increments of 0.05 to decrease the drive responsiveness during ov suppression.

- Note:**
1. PM motor control modes are not available on 600 V class drives, models 5A□□□□.
 2. This parameter is only available in AOLV/PM.

No.	Name	Setting Range	Default
n8-65	Speed Feedback Detection Control Gain during ov Suppression	0.00 to 10.00	1.50

■ n8-69: Speed Calculation Gain

Sets the proportional gain for Phase Locked Loop (PLL) control of an extended observer.

There is normally no need to change this parameter from the default value.

- Note:**
1. This parameter is valid in drive software versions PRG:1015 and later.
 2. This parameter is not available in models 4A0930 and 4A1200.

No.	Name	Setting Range	Default
n8-69	Speed Calculation Gain	0.00 to 20.00	1.00

■ n8-84: Polarity Judge Current

Sets the current to determine polarity for the initial polarity calculation as a percentage of the motor rated current.

Set the value in % unit (E5-03 = 100%)

- Note:**
1. PM motor control modes are not available on 600 V class drives, models 5A□□□□.
 2. This parameter is only available in AOLV/PM and CLV/PM.

No.	Name	Setting Range	Default
n8-84	Polarity Judge Current	0 to 150%	100%

Judging Polarity and Motor Pole Position

If operating in AOLV/PM (A1-02 = 6) or CLV/PM (A1-02 = 7), the drive determines motor polarity by performing initial polarity estimation when it starts the motor (this is done only the first time the motor is started when using CLV/PM).

The drive may begin operating in the wrong direction if it determines motor polarity incorrectly as the opposite direction of the Run command.

Monitor U6-57 displays the deviation from the integrated current, making it possible to see if initial polarity estimation has successfully determined the motor polarity.

To prevent the drive from incorrectly determining motor polarity, make sure that monitor U6-57 displays a value greater than 819 during the initial test runs for the application.

If U6-57 shows a value less than 819, then increase the polarity judge current level set in parameter n8-84.

5.10 o: Operator Related Settings

These parameters control the various functions, features, and display of the digital operator.

◆ o1: Digital Operator Display Selection

These parameters determine the data display on the digital operator.

■ o1-01: Drive Mode Unit Monitor Selection

The frequency reference display appears when the drive is powered up. Pressing the up arrow key will display the following data: frequency reference → rotational direction → output frequency → output current → o1-01 selection.

Parameter o1-01 selects the content of the last monitor in this sequence.

No.	Name	Setting Range	Default
o1-01	Drive Mode Unit Monitor Selection	104 to 813 U1-04 (Control Mode) to U8-13 (DWEZ Custom Monitor 3) </>	106 (U1-06)

<1> U2-□□ and U3-□□ parameters cannot be selected.

■ o1-02: User Monitor Selection after Power Up

Selects which monitor parameter is displayed upon power up by entering the 1- □□ part of U1-□□. Certain monitors are not available in some control modes. *Refer to U: Monitor Parameters on page 331* for a list of monitors.

No.	Name	Setting Range	Default
o1-02	User Monitor Selection after Power Up	1 to 5	1

Setting 1: Frequency reference (U1-01)

Setting 2: Motor direction

Setting 3: Output frequency (U1-02)

Setting 4: Output current (U1-03)

Setting 5: User-selected monitor (set by o1-01)

■ o1-03: Digital Operator Display Selection

Sets the units used to display the frequency reference and output frequency. Set o1-03 to 3 for user-set units before setting parameters o1-10 and o1-11.

No.	Name	Setting Range	Default
o1-03	Digital Operator Display Selection	0 to 3	Determined by A1-02

Setting 0: 0.01 Hz units

Setting 1: 0.01% units (100% = max. output frequency)

Setting 2: r/min units (calculated by the max output frequency and the no. of motor poles)

Setting 3: User-set units (use o1-10, o1-11)

Set the value used for the maximum frequency reference to o1-10. Set the placement of the decimal point in this number to o1-11.

For example, to have the maximum output frequency displayed as “100.00”, set o1-10 = 1000 and o1-11 = 2 (i.e., 1000 with 2 decimal points).

- Note:**
- Parameter o1-03 allows the programmer to change the units used in the following parameters and monitors:
 U1-01: frequency reference
 U1-02: output frequency
 U1-05: motor speed
 U1-16: output frequency after softstarter (accel/decel ramp generator)

d1-01 to d1-17: frequency references

- Setting o1-03 to 2 requires entering the number of motor poles to E2-04, E4-04, and E5-04.

■ o1-04: V/f Pattern Display Unit

Note: PM motor control modes are not available on 600 V class drives, models 5A□□□□.

Determines the units used for the frequency reference when setting parameters that create the V/f pattern: E1-04, E1-06, E1-09, E1-11, and E2-04. For motor 2, this includes parameters E3-04, E3-06, E3-07, E3-09, and E3-11. Enabled only in vector control modes (CLV, AOLV/PM, CLV/PM).

No.	Name	Setting Range	Default
o1-04	V/f Pattern Display Unit	0, 1	0

Setting 0: Hertz

Setting 1: r/min

Note: For motor 2, o1-04 can only be set to 0 for Hertz.

■ o1-10: User-Set Display Units Maximum Value

Determines the display value that is equal to the maximum output frequency.

No.	Name	Setting Range	Default
o1-10	User-Set Display Units Maximum Value	1 to 60000	Determined by o1-03

■ o1-11: User-Set Display Units Decimal Display

Determines how many decimal points should be used to set and display the frequency reference.

No.	Name	Setting Range	Default
o1-11	User-Set Display Units Decimal Display	0 to 3	Determined by o1-03

Setting 0: No Decimal Point

Setting 1: One Decimal Point

Setting 2: Two Decimal Points

Setting 3: Three Decimal Points

◆ o2: Digital Operator Keypad Functions

These parameters determine the functions assigned to the operator keys.

■ o2-01: LO/RE (LOCAL/REMOTE) Key Function Selection

Determines whether the LO/RE key on the digital operator will be enabled for switching between LOCAL and REMOTE.

No.	Name	Setting Range	Default
o2-01	LO/RE Key Function Selection	0, 1	1

Setting 0: Disabled

The LO/RE key is disabled.

Setting 1: Enabled

The LO/RE switches between LOCAL and REMOTE operation. Switching is possible during stop only. When LOCAL is selected, the LED indicator on the LO/RE key will light up.

WARNING! Sudden Movement Hazard. The drive may start unexpectedly if the Run command is already applied when switching from LOCAL mode to REMOTE mode when b1-07 = 1, resulting in death or serious injury. Check all mechanical or electrical connections thoroughly before making any setting changes to o2-01 and b1-07. [Table 5.44](#) lists the setting combinations for o2-01 and b1-07.

Table 5.44 LO/RE Key and b1-07

o2-01	b1-07	Switch from LOCAL to REMOTE	Switch from REMOTE to LOCAL
0	0	Not possible	Not possible
	1	Not possible	Not possible

5.10 o: Operator Related Settings

o2-01	b1-07	Switch from LOCAL to REMOTE	Switch from REMOTE to LOCAL
1	0	Will not run until a new Run command is entered.	Run not possible
	1	If a Run command is entered, the drive will start running as soon as the LO/RE key is pushed to change from LOCAL to REMOTE.	Run not possible

■ o2-02: STOP Key Function Selection

Determines if the STOP key on the digital operator will stop drive operation when the drive is controlled from a remote source (i.e., not from digital operator).

No.	Name	Setting Range	Default
o2-02	STOP Key Function Selection	0, 1	1

Setting 0: Disabled

Setting 1: Enabled

The STOP key will terminate drive operation even if the Run command source is not assigned to the digital operator. Cycle the Run command to restart the drive if the drive has been stopped by pressing the STOP key.

■ o2-03: User Parameter Default Value

After completely setting up drive parameters, save the values as user-set defaults with parameter o2-03. After saving the values, parameter A1-03 (Initialize Parameters) will offer the choice of "1110: User Initialize". Selecting 1110 resets all parameters to the user-set default values. [Refer to A1-03: Initialize Parameters on page 157](#) for details on drive initialization.

No.	Name	Setting Range	Default
o2-03	User Parameter Default Value	0 to 2	0

Setting 0: No Change (Awaiting Command)

Setting 1: Set User Initialize Values

The current parameter settings are saved as user-set default for a later User Initialization. Setting o2-03 to 1 and pressing the ENTER key saves the values and returns the display to 0.

Setting 2: Clear User Initialize Values

All user-set defaults for "User Initialize" are cleared. Setting o2-03 to 2 and pressing the ENTER key erases the values and returns the display to 0.

■ o2-04: Drive Model Selection

Set this parameter when replacing the control board or the terminal board. [Refer to Defaults by Drive Model and Duty Rating ND/HD on page 577](#) for information on drive model selection.

NOTICE: Drive performance will suffer and protective functions will not operate properly if the correct drive capacity is not set to o2-04.

No.	Name	Setting Range	Default
o2-04	Drive Model Selection	-	Determined by drive capacity

Note: Change o2-04 setting only when necessary.

■ o2-05: Frequency Reference Setting Method Selection

Determines if the ENTER key must be pressed after changing the frequency reference using the digital operator while in the Drive Mode.

No.	Name	Setting Range	Default
o2-05	Frequency Reference Setting Method Selection	0, 1	0

Setting 0: ENTER key required

The ENTER key must be pressed every time the frequency reference is changed using the digital operator for the drive to accept the change.

Setting 1: ENTER key not required

The output frequency changes immediately when the reference is changed by the up or down arrow keys on the digital operator. The ENTER key does not need to be pressed. The frequency reference (Fref) is saved to memory after remaining unchanged for 5 seconds.

■ o2-06: Operation Selection when Digital Operator is Disconnected

Determines whether the drive will stop when the digital operator is removed in LOCAL mode or when b1-02 or b1-16 is set to 0. When the operator is reconnected, the display will indicate that it was disconnected.

No.	Name	Setting Range	Default
o2-06	Digital Operator Disconnection Operation	0, 1	1

Setting 0: Continue operation

The operation continues.

Setting 1: Trigger a fault

The operation stops and triggers an oPr fault. The motor coasts to stop.

■ o2-07: Motor Direction at Power Up when Using Operator

Determines the direction the motor will rotate after the drive is powered up and the Run command is given from the digital operator.

Note: This parameter is effective only when the Run command is set to be given from the digital operator (b1-02, b1-16 = 0).

No.	Name	Setting Range	Default
o2-07	Motor Direction at Power Up when Using Operator	0, 1	0

Setting 0: Forward**Setting 1: Reverse****◆ o3: Copy Function**

These parameters control the Copy function of the digital operator. The Copy function stores parameter settings into the memory of the digital operator to facilitate the transfer of those settings to other drives that are the same model, capacity, and same control mode setting. *Refer to Copy Function Related Displays on page 384* for a description of errors and displays.

■ o3-01: Copy Function Selection

Instructs the drive to Read, Write, or Verify parameter settings.

No.	Name	Setting Range	Default
o3-01	Copy Function Selection	0 to 3	0

Setting 0: Copy Select (no function)**Setting 1: INV --> OP READ**

Copies all parameters from the drive to the digital operator.

Note: The copy protection for the digital operator is enabled by default. Set o3-01 to 1 to unlock copy protection.

Setting 2: OP --> INV WRITE

Copies all parameters from the digital operator to the drive.

Setting 3: OP<-->INV VERIFY

Compares the parameters in the drive with the parameter settings saved on the digital operator for matches.

5.10 o: Operator Related Settings

■ o3-02: Copy Allowed Selection

Allows and restricts the use of the Copy function.

No.	Name	Setting Range	Default
o3-02	Copy Allowed Selection	0, 1	0

Setting 0: Disabled

Setting 1: Enabled

◆ o4: Maintenance Monitor Settings

■ o4-01: Cumulative Operation Time Setting

Sets the cumulative operation time of the drive. The user can also manually set this parameter to begin keeping track of operation time from some desired value. Total operation time can be viewed in monitor U4-01.

Note: The value in o4-01 is set in 10 h units. For example, a setting of 30 will set the cumulative operation time counter to 300 h. 300 h will also be displayed in monitor U4-01.

No.	Name	Setting Range	Default
o4-01	Cumulative Operation Time Setting	0 to 9999	0

■ o4-02: Cumulative Operation Time Selection

Selects the conditions for how the drive keeps track of its total operation time. This time log can be viewed in monitor U4-01.

No.	Name	Setting Range	Default
o4-02	Cumulative Operation Time Selection	0, 1	0

Setting 0: Power on time

The drive logs the time it is connected to a power supply, regardless of whether the motor is running.

Setting 1: Run time

The drive logs the time that the output is active including when the Run command is active (even if the motor is not rotating) and when there is voltage output.

■ o4-03: Cooling Fan Operation Time Setting

Sets the value for how long the cooling fan has been operating. This value can be viewed in monitor U4-03. Parameter o4-03 also sets the base value used for the cooling fan maintenance, which is displayed in U4-04. Reset this parameter to 0 after replacing the cooling fan.

- Note:**
1. The value in o4-03 increases after every 10 hours of use. A setting of 30 will set the cooling fan operation time counter to 300 h. "300" will be displayed in monitor U4-03.
 2. The cooling fan may require maintenance at an earlier date in harsher environments.

No.	Name	Setting Range	Default
o4-03	Cooling Fan Operation Time Setting	0 to 9999	0

■ o4-05: Capacitor Maintenance Setting

Sets value of the maintenance monitor for the DC bus capacitors displayed in U4-05 as a percentage of the total expected performance life. Reset this value to 0 after replacing the DC bus capacitors.

Note: The actual maintenance time will depend on the environment where the drive is used.

No.	Name	Setting Range	Default
o4-05	Capacitor Maintenance Setting	0 to 150%	0%

■ o4-07: DC Bus Pre-Charge Relay Maintenance Setting

Sets the value of the softcharge bypass relay maintenance time displayed in U4-06 as a percentage of the total expected performance life. Reset this value to 0 after replacing the bypass relay.

Note: The actual maintenance time will depend on the environment where the drive is used.

No.	Name	Setting Range	Default
o4-07	DC Bus Pre-charge Relay Maintenance Setting	0 to 150%	0%

■ o4-09: IGBT Maintenance Setting

Sets the value of the IGBT maintenance time displayed in U4-07 as a percentage of the total expected performance life. Reset this value to 0 after replacing the IGBTs.

Note: The actual maintenance time will depend on the environment where the drive is used.

No.	Name	Setting Range	Default
o4-09	IGBT Maintenance Setting	0 to 150%	0%

■ o4-11: U2, U3 Initialization

Resets the fault trace and fault history monitors (U2-□□ and U3-□□). Initializing the drive using A1-03 does not reset these monitors.

No.	Name	Setting Range	Default
o4-11	U2, U3 Initialization	0, 1	0

Setting 0: No Action

The drive keeps the previously saved record concerning fault trace and fault history.

Setting 1: Reset Fault Data

Resets the data for the U2-□□ and U3-□□ monitors. Setting o4-11 to 1 and pressing the ENTER key erases fault data and returns the display to 0.

■ o4-12: kWh Monitor Initialization

Resets the kWh monitors U4-10 and U4-11. Initializing the drive or cycling the power does not reset these monitors.

No.	Name	Setting Range	Default
o4-12	kWh Monitor Initialization	0, 1	0

Setting 0: No Action

The kWh data are maintained.

Setting 1: Reset kWh Data

Resets the kWh counter. The monitors U4-10 and U4-11 will display “0” after they are initialized. Setting o4-12 to 1 and pressing the ENTER erases kWh data and returns the display to 0.

■ o4-13: Number of Run Commands Counter Initialization

Resets the Run command counter displayed in U4-02. Initializing the drive or cycling the power does not reset this monitor.

No.	Name	Setting Range	Default
o4-13	Number of Run Commands Counter Initialization	0, 1	0

Setting 0: No Action

The Run command data are kept.

Setting 1: Number of Run Commands Counter

Resets the Run command counter. The monitor U4-02 will show 0. Setting o4-13 to 1 and pressing the ENTER key erases the counter value and returns the display to 0.

5.10 o: Operator Related Settings

◆ q: DriveWorksEZ Parameters

These parameters are reserved for use with DriveWorksEZ. Refer to the DriveWorksEZ manual for more information.

■ q1-01 to q6-07: Reserved for Use by DriveWorksEZ

These parameters are reserved for use with DriveWorksEZ. Refer to the DriveWorksEZ manual for more information.

◆ r: DriveWorksEZ Connection Parameters

These parameters are reserved for use with DriveWorksEZ. Refer to the DriveWorksEZ manual for more information.

■ r1-01 to r1-40: DriveWorksEZ Connection Parameters

These parameters are reserved for use with DriveWorksEZ. Refer to the DriveWorksEZ manual for more information.

◆ T: Motor Tuning

Auto-Tuning automatically sets and tunes parameters required for optimal motor performance.

Refer to Auto-Tuning on page 135 for details on Auto-Tuning parameters.

5.11 U: Monitor Parameters

Monitor parameters let the user view various aspects of drive performance using the digital operator display. Some monitors can be output from terminals FM and AM by assigning the specific monitor parameter number (U□-□□) to H4-01 and H4-04. *Refer to H4-01, H4-04: Multi-Function Analog Output Terminal FM, AM Monitor Selection on page 274* for details on assigning functions to an analog output.

◆ U1: Operation Status Monitors

Status monitors display drive status data such as output frequency and output current. *Refer to U1: Operation Status Monitors on page 562* for a complete list of U1-□□ monitors and descriptions.

◆ U2: Fault Trace

Use these monitor parameters to view the status of various drive aspects when a fault occurs.

This information is helpful for determining the cause of a fault. *Refer to U2: Fault Trace on page 564* for a complete list of U2-□□ monitors and descriptions.

U2-□□ monitors are not reset when the drive is initialized. *Refer to o4-11: U2, U3 Initialization on page 329* for instructions on how to reset these monitor values.

Note: Fault histories are not kept when CPF00, CPF01, CPF06, CPF24, oFA00, oFb00, oFC00, Uv1, Uv2, or Uv3 occur.

◆ U3: Fault History

These parameters display faults that have occurred during operation as well as the drive operation time when those faults occurred. *Refer to U3: Fault History on page 566* for a complete list of U3-□□ monitors and descriptions.

U3-□□ monitors are not reset when the drive is initialized. *Refer to o4-11: U2, U3 Initialization on page 329* for instructions on how to reset these monitor values.

Note: Fault histories are not kept when CPF00, CPF01, CPF06, CPF24, oFA00, oFb00, oFC00, Uv1, Uv2, or Uv3 occur.

◆ U4: Maintenance Monitors

Maintenance monitors show:

- Runtime data of the drive and cooling fans and number of Run commands issued
- Maintenance data and replacement information for various drive components
- kWh data
- Highest peak current that has occurred and output frequency at the time the peak current occurred
- Motor overload status information
- Detailed information about the present Run command and frequency reference source selection

Refer to U4: Maintenance Monitors on page 566 for a complete list of U4-□□ monitors and descriptions.

◆ U5: PID Monitors

These monitors display various aspects of PID control. *Refer to PID Block Diagram on page 181* for details on how these monitors display PID data.

Refer to U5: PID Monitors on page 568 for a complete list of U5-□□ monitors and descriptions.

◆ U6: Operation Status Monitors

Control monitors show:

- Reference data for the output voltage and vector control
- Data on PM motor rotor synchronization, forward phase compensation, and flux positioning
- Pulse data from the PG motor encoder
- Pulse data for Zero Servo control
- ASR and Feed Forward control monitors

Refer to *Figure 5.37* and *Figure 5.38* on page 200 for details and an illustration showing where monitors are located in the ASR block.

5.11 U: Monitor Parameters

- The offset value added to the frequency reference by the frequency offset function. *Refer to Setting 44, 45, 46: Offset Frequency 1, 2, 3 on page 255.*
 - The bias value added to the frequency reference by the Up/Down 2 function (see *Setting 75, 76: Up 2/Down 2 Function*) *Refer to U6: Operation Status Monitors on page 569* for a complete list of U6-□□ monitors and descriptions.
-

◆ U8: DriveWorksEZ Monitors

These monitors are reserved for use with DriveWorksEZ.

A complete description of the U8-□□ monitors can be found in the DriveWorksEZ instruction manual.

Troubleshooting

This chapter provides descriptions of the drive faults, alarms, errors, related displays, and guidance for troubleshooting. This chapter can also serve as a reference guide for tuning the drive during a trial run.

6.1	SECTION SAFETY.....	334
6.2	MOTOR PERFORMANCE FINE-TUNING.....	336
6.3	DRIVE ALARMS, FAULTS, AND ERRORS.....	342
6.4	FAULT DETECTION.....	347
6.5	ALARM DETECTION.....	366
6.6	OPERATOR PROGRAMMING ERRORS.....	375
6.7	AUTO-TUNING FAULT DETECTION.....	379
6.8	COPY FUNCTION RELATED DISPLAYS.....	384
6.9	DIAGNOSING AND RESETTING FAULTS.....	386
6.10	TROUBLESHOOTING WITHOUT FAULT DISPLAY.....	388

6.1 Section Safety

WARNING

Electrical Shock Hazard

Do not connect or disconnect wiring while the power is on.

Failure to comply could result in death or serious injury.

Before servicing, disconnect all power to the equipment. The internal capacitor remains charged even after the power supply is turned off. The charge indicator LED will extinguish when the DC bus voltage is below 50 Vdc. To prevent electric shock, wait for at least the time specified on the warning label; after all indicators are OFF, measure for unsafe voltages to confirm the drive is safe prior to servicing.

Do not operate equipment with covers removed.

Failure to comply could result in death or serious injury.

The diagrams in this section may illustrate drives without covers or safety shields to display details. Be sure to reinstall covers or shields before operating the drives and run the drives according to the instructions described in this manual.

Always ground the motor-side grounding terminal.

Improper equipment grounding could result in death or serious injury by contacting the motor case.

Do not touch terminals before the capacitors have fully discharged.

Failure to comply could result in death or serious injury.

Before servicing, disconnect all power to the equipment. The internal capacitor remains charged even after the power supply is turned off. The charge indicator LED will extinguish when the DC bus voltage is below 50 Vdc. To prevent electric shock, wait for at least the time specified on the warning label; after all indicators are OFF, measure for unsafe voltages to confirm the drive is safe prior to servicing.

After blowing a fuse or tripping a GFCI, do not attempt to restart the drive or operate peripheral devices until five minutes pass and CHARGE lamp is OFF.

Failure to comply could result in death, serious injury, and damage to the drive.

Check wiring and peripheral device ratings to identify the cause of trips.

Contact your supplier if the cause cannot be identified.

Do not allow unqualified personnel to perform work on the drive.

Failure to comply could result in death or serious injury.

Installation, maintenance, inspection and servicing must be performed only by authorized personnel familiar with installation, adjustment and maintenance of AC drives.

Do not perform work on the drive while wearing loose clothing, jewelry, or without eye protection.

Failure to comply could result in death or serious injury.

Remove all metal objects such as watches and rings, secure loose clothing and wear eye protection before beginning work on the drive.

Do not remove covers or touch circuit boards while the power is on.

Failure to comply could result in death or serious injury.

Fire Hazard

Tighten all terminal screws to the specified tightening torque.

Loose electrical connections could result in death or serious injury by fire due to overheating of electrical connections.

Do not use an improper voltage source.

Failure to comply could result in death or serious injury by fire.

Verify that the rated voltage of the drive matches the voltage of the incoming drive input power before applying power.

⚠ WARNING**Do not use improper combustible materials.**

Failure to comply could result in death or serious injury by fire.
Attach the drive to metal or other noncombustible material.

NOTICE**Observe proper electrostatic discharge procedures (ESD) when handling the drive and circuit boards.**

Failure to comply may result in ESD damage to the drive circuitry.

Never connect or disconnect the motor from the drive while the drive is outputting voltage.

Improper equipment sequencing could result in damage to the drive.

Do not use unshielded cable for control wiring.

Failure to comply may cause electrical interference resulting in poor system performance. Use shielded twisted-pair wires and ground the shield to the ground terminal of the drive.

Do not allow unqualified personnel to use the product.

Failure to comply could result in damage to the drive or braking circuit.

Carefully review instruction manual TOBPC72060000 when connecting a dynamic braking option to the drive.

Do not modify the drive circuitry.

Failure to comply could result in damage to the drive and will void warranty.

Yaskawa is not responsible for modification of the product made by the user.

Check all the wiring after installing the drive and connecting other devices to ensure that all connections are correct.

Failure to comply could result in damage to the drive.

6.2 Motor Performance Fine-Tuning

This section offers helpful information for counteracting oscillation, hunting, and other problems that occur while performing a trial run. Refer to the section below that corresponds to the motor control method used.

Note: This section describes commonly edited parameters that may be set incorrectly. Consult Yaskawa for more information on detailed settings and for fine-tuning the drive.

◆ Fine-Tuning V/f Control and V/f Control with PG

Table 6.1 Parameters for Fine-Tuning Performance in V/f and V/f w/PG

Problem	Parameter No.	Corrective Action	Default	Suggested Setting
Motor hunting and oscillation at speeds between 10 and 40 Hz	Hunting Prevention Gain (n1-02)	<ul style="list-style-type: none"> Reduce the setting if insufficient motor torque relative to the size of the load causes hunting. Increase the setting when motor hunting and oscillation occur with a light load. Reduce the setting if hunting occurs when using a motor with a relatively low inductance, such as a high-frequency motor or a motor with a larger frame size. 	1.00	0.10 to 2.00
<ul style="list-style-type: none"> Motor noise Motor hunting and oscillation at speeds up to 40 Hz 	Carrier Frequency Selection (C6-02)	<ul style="list-style-type: none"> Increase the carrier frequency If the motor noise is too loud. Lower the carrier frequency when motor hunting and oscillation occur at speeds up to 40 Hz. The default setting for the carrier frequency depends on the drive capacity (o2-04) and the duty selection (C6-01). 	1 (2 kHz)	1 to max. setting
<ul style="list-style-type: none"> Poor torque or speed response Motor hunting and oscillation 	Torque Compensation Primary Delay Time (C4-02)	<ul style="list-style-type: none"> Reduce the setting if motor torque and speed response are too slow. Increase the setting if motor hunting and oscillation occur. 	200 ms	100 to 1000 ms
<ul style="list-style-type: none"> Poor motor torque at speeds below 10 Hz Motor hunting and oscillation 	Torque Compensation Gain (C4-01)	<ul style="list-style-type: none"> Increase the setting if motor torque is insufficient at speeds below 10 Hz. Reduce the setting if motor hunting and oscillation with a relatively light load. 	1.00	0.50 to 1.50
<ul style="list-style-type: none"> Poor motor torque at low speeds Motor instability at motor start 	Mid Output Voltage A (E1-08) Minimum Output Voltage (E1-10)	<ul style="list-style-type: none"> Increase the setting if motor torque is insufficient at speeds below 10 Hz. Reduce the setting If motor instability occurs at motor start. 	Depends on o2-04, Drive Model Selection	Default setting ±5 V
Poor speed precision (V/f control)	Slip Compensation Gain (C3-01)	Set the motor-rated current (E2-01), motor-rated slip (E2-02), and motor no-load current (E2-03), then adjust the slip compensation gain (C3-01).	0.0 (no slip compensation)	0.5 to 1.5
Poor speed precision (V/f control with PG)	ASR Proportional Gain 1 (C5-01) ASR Integral Time 1 (C5-02) <1> <2>	Adjust the ASR proportional gain 1 (C5-01) and the ASR integral time 1 (C5-02).	C5-01: 0.20 C5-02: 0.200 s	Proportional gain = 0.10 to 1.00 Integral time = 0.100 to 2.000 s

<1> ASR in V/f Control with PG only controls the output frequency, and does not allow the same high gain settings as CLV control.

<2> [Refer to C5: Automatic Speed Regulator \(ASR\) on page 200](#) for details on ASR.

◆ Fine-Tuning Open Loop Vector Control

Table 6.2 Parameters for Fine-Tuning Performance in OLV

Problem	Parameter No.	Corrective Action	Default	Suggested Setting
<ul style="list-style-type: none"> Poor motor torque and speed response Motor hunting and oscillation at speeds between 10 and 40 Hz 	AFR Gain (n2-01)	<ul style="list-style-type: none"> Gradually reduce the setting in 0.05 increments if motor torque and speed response are too slow. Gradually increase the setting in 0.05 increments if motor hunting and oscillation occur. 	1.00	0.50 to 2.00
<ul style="list-style-type: none"> Poor motor torque and speed response Motor hunting and oscillation at speeds between 10 and 40 Hz 	AFR Time Constant 1 (n2-02)	<ul style="list-style-type: none"> Gradually reduce the setting in 10 ms increments and check the performance to improve motor torque speed response. Gradually increase the setting by 50 ms increments and check the performance if motor hunting and oscillation occur as a result of load inertia. <p>Note: Ensure that $n2-02 \leq n2-03$. When changing n2-02, set C4-02 (Torque Compensation Primary Delay Time Constant 1) accordingly.</p>	50 ms	50 to 2000 ms
Overvoltage trips when accelerating, decelerating, or during sudden speed or load changes	AFR Time Constant 2 (n2-03)	<ul style="list-style-type: none"> Gradually increase the setting in 50 ms increments if overvoltage occurs. Gradually reduce the setting in 10 ms increments if response is slow. <p>Note: Ensure that $n2-02 \leq n2-03$. When making adjustments to n2-03, increase the value of C4-06 (Torque Compensation Primary Delay Time 2) proportionally.</p>	750 ms	750 to 2000 ms
	Torque Compensation Primary Delay Time Constant 2 (C4-06)	<ul style="list-style-type: none"> Gradually increase the setting in 10 ms increments and check the performance if overvoltage trips occur. Gradually reduce the setting in 2 ms increments and check the performance if response is slow. <p>Note: Ensure that $C4-02 \leq C4-06$. When changing C4-06 (Torque Compensation Primary Delay Time Constant 2), increase the value of n2-03 proportionally.</p>	150 ms	150 to 750 ms
<ul style="list-style-type: none"> Poor motor torque and speed response Motor hunting and oscillation 	Torque Compensation Primary Delay Time Constant 1 (C4-02)	<ul style="list-style-type: none"> Gradually reduce the setting in 2 ms increments and check the performance to improve motor torque speed response. Gradually increase the setting in 10 ms increments if motor hunting and oscillation occur. <p>Note: Ensure that $C4-02 \leq C4-06$. When making adjustments to C4-02, increase the Speed Feedback Detection Control (AFR) Time Constant 1 (n2-02) proportionally.</p>	20 ms	20 to 100 ms
Poor speed response and stability	Slip Compensation Primary Delay Time Constant (C3-02)	<ul style="list-style-type: none"> Gradually reduce the setting in 10 ms increments if response is slow. Gradually increase the setting in 10 ms increments if speed is unstable. 	200 ms	100 to 500 ms
Poor speed precision	Slip Compensation Gain (C3-01)	<ul style="list-style-type: none"> Gradually increase the setting in 0.1 ms increments if speed is too slow. Gradually reduce the setting in 0.1 ms increments if speed is too fast. 	1.0	0.5 to 1.5
Poor speed precision during regenerative operation	Slip Compensation Selection During Regeneration (C3-04)	Enable slip compensation during regeneration by setting parameter C3-04 = 1.	0	1
<ul style="list-style-type: none"> Motor noise Motor hunting and oscillation occur at speeds below 10 Hz 	Carrier Frequency Selection (C6-02)	<ul style="list-style-type: none"> Increase the carrier frequency if there is too much motor noise. Reduce the carrier frequency if motor hunting and oscillation occur at low speeds. <p>Note: The default setting for the carrier frequency depends on the drive capacity (o2-04) and Duty Selection (C6-01).</p>	1 (2 kHz)	0 to max. setting
<ul style="list-style-type: none"> Poor motor torque at low speeds Poor speed response Motor instability at start 	Mid Output Voltage A (E1-08) Minimum Output Voltage (E1-10)	<ul style="list-style-type: none"> Increase the setting if motor torque and speed response are too slow. Reduce the setting if the motor exhibits excessive instability at start-up. <p>Note: When working with a relatively light load, increasing this value too much can cause overtorque.</p>	Depends on o2-04, Drive Model Selection	Default setting ± 2 V

6.2 Motor Performance Fine-Tuning

When using OLV, leave the torque compensation gain (C4-01) at its default setting of 1.00.

◆ Fine-Tuning Closed Loop Vector Control

Table 6.3 Parameters for Fine-Tuning the Performance in CLV

Problem	Parameter No.	Corrective Action	Default	Suggested Setting
<ul style="list-style-type: none"> Poor torque or speed response Motor hunting and oscillation 	ASR Proportional Gain 1 (C5-01) ASR Proportional Gain 2 (C5-03) <1>	<ul style="list-style-type: none"> Gradually increase the ASR gain setting in increments of 5 if motor torque and speed response are too slow. Reduce the setting if motor hunting and oscillation occur. Only adjust parameter C5-03 when C5-05 > 0. Perform ASR Auto-Tuning if possible. 	20.00	10.00 to 50.00
<ul style="list-style-type: none"> Poor torque or speed response Motor hunting and oscillation 	ASR Integral Time 1 (C5-02) ASR Integral Time 2 (C5-04) <1>	<ul style="list-style-type: none"> Reduce the setting if motor torque and speed response are too slow. Increase the setting if motor hunting and oscillation occur. Only adjust parameter C5-04 when C5-05 > 0. 	0.500 s	0.300 to 1.000 s
Difficulty maintaining the ASR proportional gain or the integral time at the low or high end of the speed range	ASR Gain Switching Frequency (C5-07) <1>	Switch the drive between two different ASR proportional gain and integral time settings based on the output frequency.	0.0 Hz	0.0 to max output frequency
Motor hunting and oscillation	ASR Primary Delay Time Constant (C5-06) <1>	<ul style="list-style-type: none"> Gradually reduce the setting in 0.01 s increments if motor torque and speed response are too slow. Increase the setting if the load is less rigid and subject to oscillation. 	0.004 s	0.004 to 0.020 s
<ul style="list-style-type: none"> Motor noise Control motor hunting and oscillation occur at speeds below 3 Hz 	Carrier Frequency Selection (C6-02)	<ul style="list-style-type: none"> Increase the carrier frequency if there is too much motor noise. Reduce the carrier frequency if motor hunting and oscillation occur at low speeds. <p>Note: The default setting for the carrier frequency depends on the drive capacity (o2-04) and Drive Duty Selection (C6-01).</p>	1	2.0 kHz to max. setting
Overshoot or undershoot when the speed changes with high inertia load	Feed Forward Control (n5-01) Inertia Tuning (T1-01 = 8)	Set parameter n5-01 to 1 to Enable Feed Forward then perform Inertia Tuning. Manually set parameters C5-17, C5-18, and n5-03 if Inertia Tuning is not possible.	0	1

<1> Refer to C5: Automatic Speed Regulator (ASR) on page 200 for details on ASR.

◆ Fine-Tuning Open Loop Vector Control for PM Motors

PM motor control modes are not available on 600 V class drives, models 5A□□□□.

Table 6.4 Parameters for Fine-Tuning Performance in OLV/PM

Problem	Parameter No.	Corrective Action	Default	Suggested Setting
Undesirable motor performance	Motor parameters (E1-□□, E5-□□)	<ul style="list-style-type: none"> Check the settings for base and maximum frequency in the E1-□□ parameters. Check E5-□□ parameters and set motor data correctly. Do not enter line-to-line data where single-phase data is required, and vice versa. Perform Auto-Tuning. 	-	-
Poor motor torque and speed response	Load Inertia Ratio (n8-55)	Adjust parameter n8-55 to meet the load inertia ratio of the machine.	0	Close to the actual load inertia ratio
	Speed Feedback Detection Gain (n8-45)	Increase the speed feedback detection gain (n8-45).	0.8	Increase in increments of 0.05
	Torque Compensation (C4-01)	Enable torque compensation. Note: Setting this value too high can cause overcompensation and motor oscillation.	0	1
Oscillation at start or the motor stalls	Pull-In Current during Accel/Decel (n8-51)	Increase the pull-in current in n8-51	50%	Increase in steps of 5%
	DC Injection Braking Current (b2-02), DC Injection Time at Start (b2-03)	Use DC Injection Braking at start to align the rotor. This may cause a short reverse rotation at start.	b2-02 = 50% b2-03 = 0.0 s	b2-03 = 0.5 s Increase b2-02 if needed
	Load Inertia Ratio (n8-55)	Increase the load inertia ratio. Note: Setting this value too high can cause overcompensation and motor oscillation.	0	Close to the actual load inertia ratio
Stalling or oscillation occur when load is applied during constant speed	Pull-In Current Compensation Time Constant (n8-47)	Reduce n8-47 if hunting occurs during constant speed	5.0 s	Reduce in increments of 0.2 s
	Pull-In Current (n8-48)	Increase the pull-in current in n8-48.	30%	Increase in increments of 5%
	Load Inertia Ratio (n8-55)	Increase the load inertia ratio.	0	Close to the actual load inertia ratio
Hunting or oscillation occur	Speed feedback Detection Gain (n8-45)	Reduce the speed feedback detection gain in n8-45.	0.8	Increase in increments 0.05
STo fault trips when the load is not excessively high	Induced Voltage Constant (E5-09 or E5-24)	<ul style="list-style-type: none"> Check and adjust the induced voltage constant. Check the motor nameplate and the data sheet or contact the motor manufacturer. 	Depends on drive capacity and motor code	Refer to the motor data sheet or the nameplate.
Stalling or STo occurs at high speed as the output voltage becomes saturated	Output Voltage Limit (n8-62)	Set the value of the input voltage to parameter n8-62	200 Vac (200 V class) 400 Vac (400 V class)	Set equal to input voltage

6.2 Motor Performance Fine-Tuning

◆ Fine-Tuning Advanced Open Loop Vector Control for PM Motors

PM motor control modes are not available on 600 V class drives, models 5A□□□□.

Table 6.5 Parameters for Fine-Tuning Performance in AOLV/PM

Problem	Parameter No.	Corrective Action	Default	Suggested Setting
<ul style="list-style-type: none"> Poor torque or speed response Motor hunting and oscillation 	ASR Proportional Gain 1 (C5-01) ASR Proportional Gain 2 (C5-03)	<ul style="list-style-type: none"> Gradually increase the setting in increments of 5 if motor torque and speed response are too slow. Reduce the setting if motor hunting and oscillation occur. Only adjust parameter C5-03 when C5-05 > 0. 	10.00	5.00 to 30.00 </>
<ul style="list-style-type: none"> Poor torque or speed response Motor hunting and oscillation 	ASR Integral Time 1 (C5-02) ASR Integral Time 2 (C5-04)	<ul style="list-style-type: none"> Reduce the setting if motor torque and speed response are too slow. Increase the setting if motor hunting and oscillation occur. Only adjust parameter C5-04 when C5-05 > 0. 	0.500 s	0.300 to 1.000 s </>
Difficulty maintaining the ASR proportional gain or the integral time at the low or high end of the speed range	ASR Gain Switching Frequency (C5-07)	Switch the drive between two different ASR proportional gain and integral time settings based on the output frequency.	0.0%	0.0 to Max r/min
Motor hunting and oscillation	ASR Primary Delay Time Constant (C5-06)	Increase the setting if the load is less rigid and subject to oscillation.	0.010 s	0.016 to 0.035 s </>
Motor stalling makes normal operation impossible	Motor parameters (E1-□□, E5-□□)	Check the motor parameter settings.	-	-

<1> Optimal settings will differ between no-load and loaded operation.

◆ Fine-Tuning Closed Loop Vector Control for PM Motors

PM motor control modes are not available on 600 V class drives, models 5A□□□□.

Table 6.6 Parameters for Fine-Tuning Performance in CLV/PM

Problem	Parameter No.	Corrective Action	Default	Suggested Setting
<ul style="list-style-type: none"> Poor torque or speed response Motor hunting and oscillation 	ASR Proportional Gain 1 (C5-01) ASR Proportional Gain 2 (C5-03)	<ul style="list-style-type: none"> Gradually increase the setting in increments of 5 if motor torque and speed response are too slow. Reduce the setting if motor hunting and oscillation occur. Perform ASR Gain Auto-Tuning if possible 	20.00	10.00 to 50.00 </>
<ul style="list-style-type: none"> Poor torque or speed response Motor hunting and oscillation 	ASR Integral Time 1 (C5-02) ASR Integral Time 2 (C5-04)	<ul style="list-style-type: none"> Reduce the setting if torque and speed response are too slow. Increase the setting if motor hunting and oscillation occur. 	0.500 s	0.300 to 1.000 s </>
Difficulty maintaining the ASR proportional gain or the integral time at the low or high end of the speed range	ASR Gain Switching Frequency (C5-07)	Switch the drive between two different ASR proportional gain and integral time settings based on the output frequency.	0.0%	0.0 to Max r/min
Motor hunting and oscillation	ASR Primary Delay Time Constant (C5-06)	Increase the setting if the load is less rigid and subject to oscillation.	0.016 s	0.004 to 0.020 s </>
Motor stall makes normal operation impossible	Motor parameters (E1-□□, E5-□□)	Check the motor parameter settings.	-	-
Overshoot or undershoot at speed changes with high inertia load	Feed Forward Control (n5-01) Inertia Auto-Tuning (T2-01 = 8)	Set parameter n5-01 to 1 to Enable Feed Forward then perform Inertia Tuning. Manually set parameters C5-17, C5-18, and n5-03 if Inertia Tuning is not possible.	0	1

<1> Optimal settings will differ between no-load and loaded operation.

◆ Parameters to Minimize Motor Hunting and Oscillation

In addition to the parameters discussed on pages 336 through 340, parameters in [Table 6.7](#) indirectly affect motor hunting and oscillation.

Table 6.7 Parameters that Affect Control Performance in Applications

Name (Parameter No.)	Application
Dwell Function (b6-01 through b6-04)	Prevents motor speed loss by maintaining the output frequency when working with heavy loads or when there is powerful backlash on the machine side.
Droop Function (b7-01, b7-02)	Balances the load between two motors driving the same load when A1-02 is set to 3 or 7.
Accel/Decel Time (C1-01 through C1-11)	Adjusting accel and decel times will affect the torque presented to the motor during acceleration or deceleration.
S-Curve Characteristics (C2-01 through C2-04)	Prevents shock at the beginning and end of acceleration and deceleration.
Jump Frequency (d3-01 through d3-04)	Skips over the resonant frequencies of connected machinery.
Analog Filter Time Constant (H3-13)	Prevents fluctuation in the analog input signal due to noise.
Stall Prevention (L3-01 through L3-06, L3-11)	<ul style="list-style-type: none"> Prevents motor speed loss and overvoltage when the load is too heavy or during sudden acceleration/ deceleration. Adjustment is not normally necessary because Stall Prevention is enabled as a default. Set L3-04 to 0 to disable Stall Prevention during deceleration when using a braking resistor.
Torque Limits (L7-01 through L7-04, L7-06, L7-07)	<ul style="list-style-type: none"> Sets the maximum torque for OLV Control. Ensure that the drive capacity is greater than the motor capacity when increasing this setting. Motor speed loss may occur with heavy loads.
Feed Forward Control (n5-01 through n5-03)	Increases response for acceleration/deceleration and reduces overshooting when there is low machine rigidity and ASR gain cannot be increased. Set the inertia ratio between the load and motor and the acceleration time of the motor running alone.

6.3 Drive Alarms, Faults, and Errors

◆ Types of Alarms, Faults, and Errors

Check the digital operator for information about possible faults if the drive or motor fails to operate. *Refer to Using the Digital Operator on page 115.*

If problems occur that are not covered in this manual, contact the nearest Yaskawa representative with the following information:

- Drive model
- Software version
- Date of purchase
- Description of the problem

Table 6.8 contains descriptions of the various types of alarms, faults, and errors that may occur while operating the drive.

Table 6.8 Types of Alarms, Faults, and Errors

Type	Drive Response
Faults	<p>When the drive detects a fault:</p> <ul style="list-style-type: none"> • The digital operator displays text indicating the specific fault and the ALM indicator LED remains lit until the fault is reset. • The fault interrupts drive output and the motor coasts to a stop. • Some faults allow the user to select the stopping method when the fault occurs. • Fault output terminals MA-MC will close, and MB-MC will open. <p>The drive will remain inoperable until the fault is cleared. <i>Refer to Fault Reset Methods on page 387.</i></p>
Minor Faults and Alarms	<p>When the drive detects an alarm or a minor fault:</p> <ul style="list-style-type: none"> • The digital operator displays text indicating the specific alarm or minor fault, and the ALM indicator LED flashes. • The drive continues running the motor, although some alarms allow the user to select a stopping method when the alarm occurs. • A multi-function contact output set to be tripped by a minor fault (H2- □□ = 10) closes. If the output is set to be tripped by an alarm, the contact will not close. • The digital operator displays text indicating a specific alarm and the ALM indicator LED flashes. <p>Remove the cause of the problem to reset a minor fault or alarm.</p>
Operation Errors	<p>An operation error occurs when parameter settings conflict or do not match hardware settings (such as with an option card). When the drive detects an operation error:</p> <ul style="list-style-type: none"> • The digital operator displays text indicating the specific error. • Multi-function contact outputs do not operate. <p>The drive will not operate the motor until the error has been reset. Correct the settings that caused the operation error to clear the error.</p>
Tuning Errors	<p>Tuning errors occur while performing Auto-Tuning. When the drive detects a tuning error:</p> <ul style="list-style-type: none"> • The digital operator displays text indicating the specific error. • Multi-function contact outputs do not operate. • Motor coasts to stop. <p>Remove the cause of the error and repeat the Auto-Tuning process.</p>
Copy Function Errors	<p>Copy Function Errors occur when using the digital operator or the USB Copy Unit to copy, read, or verify parameter settings.</p> <ul style="list-style-type: none"> • The digital operator displays text indicating the specific error. • Multi-function contact outputs do not operate. <p>Pressing any key on the digital operator will clear the fault. Investigate the cause of the problem (such as model incompatibility) and try again.</p>

◆ Alarm and Error Displays

■ Faults

Table 6.9 gives an overview of possible fault codes. Conditions such as overvoltages can trip faults and alarms. It is important to distinguish between faults and alarms to determine the proper corrective actions.

When the drive detects a fault, the ALM indicator LED lights, the fault code appears on the digital operator, and the fault contact MA-MB-MC triggers. An alarm is present if the ALM LED blinks and the fault code on the digital operator flashes. **Refer to *Minor Faults and Alarms on page 344*** for a list of alarm codes.

Table 6.9 Fault Displays

Digital Operator Display	Name	Page	Digital Operator Display	Name	Page
<i>boL</i>	boL	Braking Transistor Overload Fault	<i>FbL</i>	FbL	PID Feedback Loss
<i>bUS</i>	bUS	Option Communication Error	<i>GF</i>	GF	Ground Fault
<i>CE</i>	CE	MEMOBUS/Modbus Communication Error	<i>LF</i>	LF	Output Phase Loss
<i>CF</i>	CF	Control Fault	<i>LF2</i>	LF2	Current Imbalance
<i>[PF00,</i> <i>[PF01</i> <i><1></i>	CPF11 to CPF14	Control Circuit Error	<i>LF3</i> <i><3></i>	LF3	Power Unit Output Phase Loss 3
	CPF16 to CPF19	Control Circuit Error	<i>LSo</i> <i><4></i>	LSo	LSo Fault
<i>[PF02</i>	CPF02	A/D Conversion Error	<i>nSE</i>	nSE	Node Setup Error
<i>[PF03</i>	CPF03	Control Board Connection Error	<i>oC</i>	oC	Overcurrent
<i>[PF06</i> <i><1></i>	CPF06	EEPROM Memory Data Error	<i>oFA00</i> <i><5></i>	oFA00	Option Card Connection Error (CN5-A)
<i>[PF07,</i> <i>[PF08</i>	CPF07, CPF08	Terminal Board Connection Error	<i>oFA01</i>	oFA01	Option Card Fault (CN5-A)
<i>[PF20,</i> <i>[PF21</i> <i><2></i>	CPF20, CPF21	Control Circuit Error	<i>oFA03</i> to <i>oFA06</i>	oFA03 to oFA06	Option Card Error (CN5-A)
<i>[PF22</i>	CPF22	Hybrid IC Error	<i>oFA10,</i> <i>oFA11</i>	oFA10, oFA11	Option Card Error (CN5-A)
<i>[PF23</i>	CPF23	Control Board Connection Error	<i>oFA12</i> to <i>oFA17</i>	oFA12 to oFA17	Option Card Connection Error (CN5-A)
<i>[PF24</i>	CPF24	Drive Unit Signal Fault	<i>oFA30</i> to <i>oFA43</i>	oFA30 to oFA43	Comm Option Card Connection Error (CN5-A)
<i>[PF25</i>	CPF25	Terminal Board Not Connected	<i>oFb00</i> <i><5></i>	oFb00	Option Card Connection Error (CN5-B)
<i>[PF26</i> to <i>[PF35,</i> <i>[PF40</i> to <i>[PF45</i> <i><3></i>	CPF26 to CPF35, CPF40 to CPF45	Control Circuit Error	<i>oFb01</i>	oFb01	Option Card Fault (CN5-B)
<i>dEv</i>	dEv	Excessive Speed Deviation (for Control Mode with PG)	<i>oFb02</i>	oFb02	Option Card Fault (CN5-B)
<i>dv1</i>	dv1	Z Pulse Fault Detection	<i>oFb03,</i> <i>oFb11</i>	oFb03, oFb11	Option Card Error (CN5-B)
<i>dv2</i>	dv2	Z Pulse Noise Fault Detection	<i>oFb12</i> to <i>oFb17</i>	oFb12 to oFb17	Option Card Connection Error (CN5-B)
<i>dv3</i>	dv3	Inversion Detection	<i>oFC00</i> <i><5></i>	oFC00	Option Card Connection Error (CN5-C)
<i>dv4</i>	dv4	Inversion Prevention Detection	<i>oFC01</i>	oFC01	Option Card Fault (CN5-C)
<i>dv7</i> <i><3></i>	dv7	Polarity Judge Timeout	<i>oFC02</i>	oFC02	Option Card Fault (CN5-C)
<i>dWFL</i>	dWFL	DriveWorksEZ Fault	<i>oFC03,</i> <i>oFC11</i>	oFC03, oFC11	Option Card Error (CN5-C)
<i>E5</i>	E5	SI-T3 Watchdog Timer Error	<i>oFC12</i> to <i>oFC17</i>	oFC12 to oFC17	Option Card Connection Error (CN5-C)
<i>EF0</i>	EF0	Option Card External Fault	<i>oFC50</i> to <i>oFC55</i>	oFC50 to oFC55	Option Card Error (CN5-C)
<i>EF1</i> to <i>EF8</i>	EF1 to EF8	External Fault (input terminal S1 to S8)	<i>oH</i>	oH	Heatsink Overheat
<i>Err</i>	Err	EEPROM Write Error	<i>oH1</i>	oH1	Heatsink Overheat
<i>FAn</i>	FAn	Internal Fan Fault	<i>oH3</i>	oH3	Motor Overheat Alarm (PTC input)
<i>FbH</i>	FbH	Excessive PID Feedback	<i>oH4</i>	oH4	Motor Overheat Fault (PTC input)

6.3 Drive Alarms, Faults, and Errors

Digital Operator Display		Name	Page
$oH5$ <3>	oH5	Motor Overheat (NTC Input)	357
$oL1$	oL1	Motor Overload	358
$oL2$	oL2	Drive Overload	358
$oL3$	oL3	Overtorque Detection 1	359
$oL4$	oL4	Overtorque Detection 2	359
$oL5$	oL5	Mechanical Weakening Detection 1	359
$oL7$	oL7	High Slip Braking oL	359
oPr	oPr	Operator Connection Fault	360
oS	oS	Overspeed	360
ov	ov	Overvoltage	360
PF	PF	Input Phase Loss	361
PGo	PGo	PG Disconnect (for Control Mode with PG)	361
$PGoH$	PGoH	PG Hardware Fault (when using PG-X3)	361
rF	rF	Braking Resistor Fault	361
rH	rH	Dynamic Braking Resistor	362
rr	rr	Dynamic Braking Transistor	362
SC	SC	IGBT Short Circuit or Ground Fault	362

Digital Operator Display		Name	Page
SEr	SEr	Too Many Speed Search Restarts	362
STo	STo	Pull-Out Detection	363
SvE	SvE	Zero-Servo Fault	363
THo <3>	THo	Thermistor Disconnect	363
$UL3$	UL3	Undertorque Detection 1	363
$UL4$	UL4	Undertorque Detection 2	363
$UL5$	UL5	Mechanical Weakening Detection 2	363
$UnbC$ <3>	UnbC	Current Unbalance	363
$Uv1$ <3> <5>	Uv1	Undervoltage	364
$Uv2$ <5>	Uv2	Control Power Supply Undervoltage	364
$Uv3$ <5>	Uv3	Soft Charge Circuit Fault	364
$Uv4$ <3>	Uv4	Gate Drive Board Undervoltage	364
voF	voF	Output Voltage Detection Fault	365

- <1> Displayed as $CPF00$ when occurring at drive power up. When one of the faults occurs after successfully starting the drive, the display will show $CPF01$.
- <2> Displayed as $CPF20$ when occurring at drive power up. When one of the faults occurs after successfully starting the drive, the display will show $CPF21$.
- <3> Detected in models 4A0930 and 4A1200.
- <4> This function prevents continuous operation in reverse when using high frequency injection (n8-57 = 1) in AOLV/PM (A1-02 = 6) with a motor for which no motor code has been entered (it does not only prevent reverse operation). Set L8-93, L8-94, and L8-95 to low values within range of erroneous detection to quickly detect undesirable reverse operation.
- <5> Fault histories are not kept when CPF00, CPF01, CPF06, CPF24, oFA00, oFb00, oFC00, Uv1, Uv2, or Uv3 occur.

Minor Faults and Alarms

Refer to [Table 6.10](#) for an overview of possible alarm codes. Conditions such as overvoltages can trip faults and alarms. It is important to distinguish between faults and alarms to determine the proper corrective actions.

When the drive detects an alarm, the ALM indicator LED blinks and the alarm code display flashes. Most alarms trigger a digital output programmed for alarm output (H2-□□ = 10). A fault (not an alarm) is present if the ALM LED lights without blinking. [Refer to Faults on page 343](#) for information on fault codes.

Table 6.10 Minor Fault and Alarm Displays

Digital Operator Display		Name	Minor Fault Output (H2-□□ = 10)	Page	Digital Operator Display		Name	Minor Fault Output (H2-□□ = 10)	Page
AEr	AEr	SI-T Station Number Setting Error (CC-Link, CANopen, MECHATROLINK-II)	YES	366	dEv	dEv	Excessive Speed Deviation (for Control Mode with PG)	YES	367
bb	bb	Drive Baseblock	No output	366	dnE	dnE	Drive Disabled	YES	368
boL	boL	Braking Transistor Overload Fault	YES	366	$dWAL$	dWAL	DriveWorksEZ Alarm	YES	351
bUS	bUS	Option Card Communications Error	YES	366	$E5$	E5	SI-T3 Watchdog Timer Error	YES	351
$CALL$	CALL	Serial Communication Transmission Error	YES	366	EF	EF	Run Command Input Error	YES	368
CE	CE	MEMOBUS/Modbus Communication Error	YES	367	$EF0$	EF0	Option Card External Fault	YES	368
$CrST$	CrST	Cannot Reset	YES	367	$EF1$ to $EF8$	EF1 to EF8	External Fault (input terminal S1 to S8)	YES	368
					FbH	FbH	Excessive PID Feedback	YES	368
					FbL	FbL	PID Feedback Loss	YES	369

Digital Operator Display		Name	Minor Fault Output (H2-□□ = 10)	Page
Hbb	Hbb	Safe Disable Signal Input <3>	YES	369
HbbF	HbbF	Safe Disable Signal Input <3>	YES	369
HCA	HCA	Current Alarm	YES	369
LT-1	LT-1	Cooling Fan Maintenance Time	No output <1>	370
LT-2	LT-2	Capacitor Maintenance Time	No output <1>	370
LT-3	LT-3	Soft Charge Bypass Relay Maintenance Time	No output <1>	370
LT-4	LT-4	IGBT Maintenance Time (50%)	No output <1>	370
oH	oH	Heatsink Overheat	YES	370
oH2	oH2	Drive Overheat	YES	370
oH3	oH3	Motor Overheat	YES	371
oH5 <2>	oH5	Motor Overheat (NTC Input)	YES	371
oL3	oL3	Overtorque 1	YES	371
oL4	oL4	Overtorque 2	YES	371
oL5	oL5	Mechanical Weakening Detection 1	YES	371

Digital Operator Display		Name	Minor Fault Output (H2-□□ = 10)	Page
oS	oS	Overspeed	YES	372
ov	ov	Overvoltage	YES	372
PASS	PASS	MEMOBUS/Modbus Test Mode Complete	No output	372
PGo	PGo	PG Disconnect (for Control Mode with PG)	YES	372
PGoH	PGoH	PG Hardware Fault (when using PG-X3)	YES	372
rUn	rUn	During Run 2, Motor Switch Command Input	YES	373
SE	SE	MEMOBUS/Modbus Test Mode Fault	YES	373
THo <2>	THo	Thermistor Disconnect	YES	373
TrPC	TrPC	IGBT Maintenance Time (90%)	YES	373
UL3	UL3	Undertorque 1	YES	373
UL4	UL4	Undertorque 2	YES	373
UL5	UL5	Mechanical Weakening Detection 2	YES	363
Uv	Uv	Undervoltage	YES	373
voF	voF	Output Voltage Detection Fault	YES	374

<1> Output when H2-□□ = 2F.

<2> Detected in models 4A0930 and 4A1200.

<3> Terminals H1, H2, DM+, and DM- on 600 V class models are designed to the functionality, but are not certified to EN61800-5-1, ISO13849 Cat. 3, IEC/EN61508 SIL2, Insulation coordination: class 1.

■ Operation Errors

Table 6.11 Operation Error Displays

Digital Operator Display		Name	Page
oPE01	oPE01	Drive Unit Setting Error	375
oPE02	oPE02	Parameter Setting Range Error	375
oPE03	oPE03	Multi-Function Input Setting Error	375
oPE04	oPE04	Terminal Board Mismatch Error	376
oPE05	oPE05	Run Command Selection Error	376
oPE06	oPE06	Control Method Selection Error	376
oPE07	oPE07	Multi-Function Analog Input Selection Error	377
oPE08	oPE08	Parameter Selection Error	377

Digital Operator Display		Name	Page
oPE09	oPE09	PID Control Selection Error	377
oPE10	oPE10	V/f Data Setting Error	378
oPE11	oPE11	Carrier Frequency Setting Error	378
oPE13	oPE13	Pulse Train Monitor Selection Error	378
oPE15	oPE15	Torque Control Setting Error	378
oPE16	oPE16	Energy Saving Constants Error	378
oPE18	oPE18	Online Tuning Parameter Setting Error	378

Auto-Tuning Errors

Table 6.12 Auto-Tuning Error Displays

Digital Operator Display	Name	Page	Digital Operator Display	Name	Page
<i>End1</i>	End1 Excessive V/f Setting	379	<i>Er-09</i>	Er-09 Acceleration Error	381
<i>End2</i>	End2 Motor Iron Core Saturation Coefficient Error	379	<i>Er-10</i>	Er-10 Motor Direction Error	381
<i>End3</i>	End3 Rated Current Setting Alarm	379	<i>Er-11</i>	Er-11 Motor Speed Error	381
<i>End4</i>	End4 Adjusted Slip Value Fell Below Lower Limit	379	<i>Er-12</i>	Er-12 Current Detection Error	381
<i>End5</i>	End5 Resistance Between Lines Error	379	<i>Er-13</i>	Er-13 Leakage Inductance Error	382
<i>End6</i>	End6 Leakage Inductance Alarm	379	<i>Er-14</i>	Er-14 Motor Speed Error 2	382
<i>End7</i>	End7 No-Load Current Alarm	380	<i>Er-15</i>	Er-15 Torque Saturation Error	382
<i>Er-01</i>	Er-01 Motor Data Error	380	<i>Er-16</i>	Er-16 Inertia ID Error	382
<i>Er-02</i>	Er-02 Alarm	380	<i>Er-17</i>	Er-17 Reverse Prohibited Error	382
<i>Er-03</i>	Er-03 STOP Button Input	380	<i>Er-18</i>	Er-18 Induction Voltage Error	382
<i>Er-04</i>	Er-04 Line-to-Line Resistance Error	380	<i>Er-19</i>	Er-19 PM Inductance Error	382
<i>Er-05</i>	Er-05 No-Load Current Error	380	<i>Er-20</i>	Er-20 Stator Resistance Error	382
<i>Er-08</i>	Er-08 Rated Slip Error	381	<i>Er-21</i>	Er-21 Z Pulse Correction Error	383

Errors and Displays When Using the Copy Function

Table 6.13 Copy Errors

Digital Operator Display	Name	Page	Digital Operator Display	Name	Page
<i>CoPy</i>	CoPy Writing parameter settings (flashing)	384	<i>rdEr</i>	rdEr Error reading data	385
<i>CPEr</i>	CPEr Control mode mismatch	384	<i>rEAd</i>	rEAd Reading parameter settings (flashing)	385
<i>CPyE</i>	CPyE Error writing data	384	<i>vAEr</i>	vAEr Voltage class, capacity mismatch	385
<i>CSEr</i>	CSEr Copy unit error	384	<i>vFyE</i>	vFyE Parameter setting mismatch	385
<i>dFPS</i>	dFPS Drive model mismatch	384	<i>vrFy</i>	vrFy Comparing parameter settings (flashing)	385
<i>End</i>	End Task complete	384			
<i>iFEr</i>	iFEr Communication error	384			
<i>ndAT</i>	ndAT Model, voltage class, capacity mismatch	385			

6.4 Fault Detection

◆ Fault Displays, Causes, and Possible Solutions

Faults are detected for drive protection, and cause the drive to stop while triggering the fault output terminal MA-MB-MC. Remove the cause of the fault and manually clear the fault before attempting to run the drive again.

Table 6.14 Detailed Fault Displays, Causes, and Possible Solutions

Digital Operator Display		Fault Name
<i>boL</i>	boL	Braking Transistor Overload Fault
Cause		Possible Solution
The wrong braking resistor is installed		Select the correct braking resistor.
Digital Operator Display		Fault Name
<i>bUS</i>	bUS	Option Communication Error
Cause		Possible Solution
No signal was received from the PLC		<ul style="list-style-type: none"> • Check for faulty wiring. • Correct the wiring. • Check for disconnected cables and short circuits and repair as needed.
Faulty communications wiring or an existing short circuit		<ul style="list-style-type: none"> • Check the various options available to minimize the effects of noise. • Counteract noise in the control circuit, main circuit, and ground wiring. • Ensure that other equipment such as switches or relays do not cause noise. Use surge absorbers if necessary. • Use only recommended cables or other shielded line. Ground the shield on the controller side or the drive input power side. • Separate all communication wiring from drive power lines. Install an EMC noise filter to the drive power supply input.
Communication data error occurred due to noise		
The option card is damaged		Replace the option card if there are no problems with the wiring and the error continues to occur.
The option card is not properly connected to the drive		<ul style="list-style-type: none"> • The connector pins on the option card do not line up properly with the connector pins on the drive. • Reinstall the option card.
Digital Operator Display		Fault Name
<i>CE</i>	CE	MEMOBUS/Modbus Communication Error
Cause		Possible Solution
Faulty communications wiring or an existing short circuit		<ul style="list-style-type: none"> • Check for faulty wiring. • Correct the wiring. • Check for disconnected cables and short circuits and repair as needed.
Communication data error occurred due to noise		<ul style="list-style-type: none"> • Check the various options available to minimize the effects of noise. • Counteract noise in the control circuit, main circuit, and ground wiring. • Use only recommended cables or other shielded line. Ground the shield on the controller side or the drive input power side. • Ensure that other equipment such as switches or relays do not cause noise. Use surge suppressors if required. • Separate all communication wiring from drive power lines. Install an EMC noise filter to the drive power supply input.
Control data was not received for the CE detection time set to H5-09.		
Digital Operator Display		Fault Name
<i>CF</i>	CF	Control Fault
Cause		Possible Solution
Motor parameters are set improperly		Check the motor parameter settings and repeat Auto-Tuning.
Torque limit is too low		Set the torque limit to the most appropriate setting (L7-01 through L7-04).

6.4 Fault Detection

Load inertia is too big	<ul style="list-style-type: none"> Adjust the deceleration time (C1-02, C1-04, C1-06, C1-08). Set the frequency to the minimum value and interrupt the Run command when the drive finishes decelerating.
-------------------------	--

Digital Operator Display		Fault Name
<i>CPF00</i> or <i>CPF01</i>	CPF11 to CPF14 CPF16 to CPF19	Control Circuit Error
Cause		Possible Solution
There is a self-diagnostic error in the control circuit		<ul style="list-style-type: none"> Cycle power to the drive. If the problem continues, replace the control board or the entire drive. Contact Yaskawa or a Yaskawa representative for instructions on replacing the control board.
Connector on the operator is damaged		Replace the operator.

Digital Operator Display		Fault Name
<i>CPF02</i>	CPF02	A/D Conversion Error
Cause		Possible Solution
Control circuit is damaged		<ul style="list-style-type: none"> Cycle power to the drive. If the problem continues, replace the control board or the entire drive. Contact Yaskawa or a Yaskawa representative for instructions on replacing the control board.

Digital Operator Display		Fault Name
<i>CPF03</i>	CPF03	Control Board Connection Error
Cause		Possible Solution
There is a connection error		<ul style="list-style-type: none"> Turn off the power and check the connection between the control board and the drive. If the problem continues, replace the control board or the entire drive. Contact Yaskawa or a Yaskawa representative for instructions on replacing the control board.
Drive fails to operate properly due to noise interference		<ul style="list-style-type: none"> Check the various options available to minimize the effects of noise. Counteract noise in the control circuit, main circuit, and ground wiring. Use only recommended cables or other shielded line. Ground the shield on the controller side or the drive input power side. Ensure that other equipment such as switches or relays do not cause noise. Use surge suppressors if required. Separate all communication wiring from drive power lines. Install an EMC noise filter to the drive power supply input.

Digital Operator Display		Fault Name
<i>CPF06</i>	CPF06	EEPROM Memory Data Error
Cause		Possible Solution
There is an error in EEPROM control circuit		<ul style="list-style-type: none"> Turn off the power and check the connection between the control board and the drive. If the problem continues, replace the control board or the entire drive. Contact Yaskawa or a Yaskawa representative for instructions on replacing the control board.
The power supply was switched off while parameters were being saved to the drive		Reinitialize the drive (A1-03 = 2220, 3330).

Digital Operator Display		Fault Name
<i>CPF07</i>	CPF07	Terminal Board Connection Error
<i>CPF08</i>	CPF08	
Cause		Possible Solution
There is a faulty connection between the terminal board and the control board		<ul style="list-style-type: none"> Turn off the power and reconnect the terminal board. If the problem continues, replace the control board or the entire drive. Contact Yaskawa or a Yaskawa representative for instructions on replacing the control board.

Digital Operator Display		Fault Name
<i>CPF20</i> or <i>CPF21</i>	CPF20 or CPF21	Control Circuit Error
Cause		Possible Solution

Hardware is damaged	<ul style="list-style-type: none"> • Cycle power to the drive. • If the problem continues, replace the control board or the entire drive. Contact Yaskawa or a Yaskawa representative for instructions on replacing the control board.
---------------------	--

Digital Operator Display		Fault Name
<i>CPF22</i>	CPF22	Hybrid IC Failure
Cause		Possible Solution
Hybrid IC failure on the power board		<ul style="list-style-type: none"> • Cycle power to the drive. • If the problem continues, replace the power board or the entire drive. Contact Yaskawa or a Yaskawa representative for instructions on replacing the power board.

Digital Operator Display		Fault Name
<i>CPF23</i>	CPF23	Control Board Connection Error
Cause		Possible Solution
Hardware is damaged		<ul style="list-style-type: none"> • Turn off the power and check the connection between the control board and the drive. • If the problem continues, replace the control board or the entire drive. Contact Yaskawa or a Yaskawa representative for instructions on replacing the control board.

Digital Operator Display		Fault Name
<i>CPF24</i>	CPF24	Drive Unit Signal Fault
Cause		Possible Solution
Hardware is damaged		If the problem continues, replace the control board or the entire drive. Contact Yaskawa or a Yaskawa representative for instructions on replacing the control board.

Digital Operator Display		Fault Name
<i>CPF25</i>	CPF25	Terminal Board Not Connected
Cause		Possible Solution
Terminal board is not connected correctly		Reconnect the terminal board to the connector on the drive, then cycle the power to the drive.

Digital Operator Display		Fault Name
<i>CPF26 to CPF35</i> <i>CPF40 to CPF45</i>	CPF26 to CPF35 CPF40 to CPF45	Control Circuit Error
Cause		Possible Solution
Hardware is damaged		If the problem continues, replace the control board or the entire drive. Contact Yaskawa or a Yaskawa representative for instructions on replacing the control board.

Digital Operator Display		Fault Name
<i>dEv</i>	dEv	Speed Deviation (for Control Mode with PG)
Cause		Possible Solution
Load is too heavy		Reduce the load.
Acceleration and deceleration times are set too short		Increase the acceleration and deceleration times (C1-01 through C1-08).
The load is locked up		Check the machine.
Parameters are not set appropriately		Check the settings of parameters F1-10 and F1-11.
Incorrect speed feedback scaling when using terminal RP as speed feedback input in V/f control		<ul style="list-style-type: none"> • Set H6-02 to the same value as the speed feedback signal frequency when the motor runs at maximum speed. • Adjust the speed feedback signal using parameters H6-03 through H6-05. • Make sure the speed feedback signal frequency does not exceed the maximum input frequency of terminal RP.
Motor brake is engaged		Ensure the motor brake releases properly.

Digital Operator Display		Fault Name
<i>dv1</i>	dv1	Z Pulse Fault
		The motor turned one full rotation without the Z Pulse being detected.

6.4 Fault Detection

Cause	Possible Solution
PG encoder is disconnected, improperly wired, or the PG option card or PG encoder are damaged	<ul style="list-style-type: none"> Make sure the PG encoder is properly connected and all shielded lines are properly grounded. If the problem continues after cycling power, replace the PG option card or the PG encoder.

Digital Operator Display		Fault Name
d_{u2}	dv2	Z Pulse Noise Fault Detection
		The Z Pulse is out of phase by more than 5 degrees for the number of times specified in parameter F1-17.
Cause		Possible Solution
Noise interference along the PG cable		Separate the PG cable lines from the source of the noise.
PG cable is not wired properly		Rewire the PG encoder and properly ground all shielded lines.
PG option card or the PG encoder are damaged		If the problem continues after cycling power, replace the PG option card or the PG encoder.

Digital Operator Display		Fault Name
d_{u3}	dv3	Inversion Detection
		The torque reference and acceleration are in opposite directions and the speed reference and actual motor speed differ by more than 30% for the number of times set to F1-18.
Cause		Possible Solution
The Z Pulse offset is not set properly to E5-11		Set the value for $\Delta\theta$ to E5-11 as specified on the motor nameplate. Replacing the PG encoder or changing the application to rotate the motor in reverse requires readjustment of the Z-pulse offset. (T2-01 = 3)
An external force on the load side caused the motor to move		<ul style="list-style-type: none"> Make sure the motor is rotating in the proper direction. Identify and fix any problems on the load side causing the motor to rotate in the opposite direction.
Noise interference along the PG cable affecting the A or B pulse		Properly rewire the PG encoder and connect all lines including shielded line.
PG encoder is disconnected, improperly wired, or the PG option card or PG encoder are damaged		
Rotational direction for the PG encoder set to F1-05 is the opposite of the motor line order		Properly connect the motor lines for each phase (U, V, W).

Digital Operator Display		Fault Name
d_{u4}	dv4	Inversion Prevention Detection
		Pulses indicate that the motor is rotating in the opposite direction of the speed reference. Set the number of pulses to trigger inverse detection to F1-19.
		Note: Set F1-19 to 0 to disable inverse detection in applications where the motor may rotate in the opposite direction of the speed reference.
Cause		Possible Solution
The Z Pulse offset is not set properly to E5-11		<ul style="list-style-type: none"> Set the value for $\Delta\theta$ to E5-11 as specified on the motor nameplate. If the problem continues after cycling power, replace the PG option card or the PG encoder. Replacing the PG encoder or changing the application to rotate the motor in reverse requires readjustment of the Z-pulse offset. (T2-01 = 3)
Noise interference along the PG cable affecting the A or B pulse		<ul style="list-style-type: none"> Make sure the motor is rotating in the proper direction. Identify and fix any problems on the load side causing the motor to rotate in the opposite direction.
PG encoder is disconnected, improperly wired, or the PG option card or PG encoder are damaged		<ul style="list-style-type: none"> Rewire the PG encoder and properly connect all lines including shielded line. If the problem continues after cycling power, replace the PG option card or the PG encoder.

Digital Operator Display		Fault Name
d_{u7} </>	dv7	Polarity Judge Timeout
Cause		Possible Solution
Disconnection in the motor coil winding		<ul style="list-style-type: none"> Measure the motor line-to-line resistance and replace the motor if the motor coil winding is disconnected.
Loose output terminals		<ul style="list-style-type: none"> Check for loose terminals. Apply the tightening torque specified in this manual to fasten the terminals. <i>Refer to Wire Gauges and Tightening Torque on page 89</i> for details.

<1> Available in drive software versions 1015 and later.

Digital Operator Display		Fault Name
<i>dWAL</i>	dWAL	DriveWorksEZ Fault
<i>dWFL</i>	dWFL	
Cause		Possible Solution
Fault output by DriveWorksEZ		Correct the cause of the fault.

Digital Operator Display		Fault Name
<i>E5</i>	E5	SI-T3 Watchdog Timer Error
		The watchdog timed out.
Cause		Possible Solution
Data has not been received from the PLC		Execute DISCONNECT or ALM_CLR, then issue a CONNECT command or SYNC_SET command and proceed to phase 3. Refer to the SI-T3 Option Technical Manual for more details on troubleshooting.

Digital Operator Display		Fault Name
<i>EF0</i>	EF0	Option Card External Fault
		An external fault condition is present.
Cause		Possible Solution
An external fault was received from the PLC and F6-03 is set to a value other than 3.		<ul style="list-style-type: none"> Remove the cause of the external fault. Remove the external fault input from the PLC.
Problem with the PLC program		Check the PLC program and correct problems.

Digital Operator Display		Fault Name
<i>EF1</i>	EF1	External Fault (input terminal S1)
		External fault at multi-function input terminal S1.
<i>EF2</i>	EF2	External Fault (input terminal S2)
		External fault at multi-function input terminal S2.
<i>EF3</i>	EF3	External Fault (input terminal S3)
		External fault at multi-function input terminal S3.
<i>EF4</i>	EF4	External Fault (input terminal S4)
		External fault at multi-function input terminal S4.
<i>EF5</i>	EF5	External Fault (input terminal S5)
		External fault at multi-function input terminal S5.
<i>EF6</i>	EF6	External Fault (input terminal S6)
		External fault at multi-function input terminal S6.
<i>EF7</i>	EF7	External Fault (input terminal S7)
		External fault at multi-function input terminal S7.
<i>EF8</i>	EF8	External Fault (input terminal S8)
		External fault at multi-function input terminal S8.
Cause		Possible Solution
An external device tripped an alarm function		Remove the cause of the external fault and reset the fault.
Wiring is incorrect		<ul style="list-style-type: none"> Properly connect the signal lines to the terminals assigned for external fault detection (H1-□□ = 20 to 2B). Reconnect the signal line.
Multi-function contact input setting is incorrect		<ul style="list-style-type: none"> Check for unused terminals set for H1-□□ = 20 to 2B (External Fault). Change the terminal settings.

Digital Operator Display		Fault Name
<i>Err</i>	Err	EEPROM Write Error
		Data cannot be written to the EEPROM
Cause		Possible Solution

6.4 Fault Detection

Noise has corrupted data while writing to the EEPROM	<ul style="list-style-type: none"> Press “ENTER” on the digital operator. Correct the parameter setting. Cycle power to the drive. If the problem continues, replace the control board or the entire drive. Contact Yaskawa or a Yaskawa representative for instructions on replacing the control board.
Hardware problem	If the problem continues, replace the control board or the entire drive. Contact Yaskawa or a Yaskawa representative for instructions on replacing the control board.

Digital Operator Display		Fault Name
FAn	FAn	Internal Fan Fault
Cause		Possible Solution
Internal cooling fan has malfunctioned		<ul style="list-style-type: none"> Cycle power to the drive. Check for fan operation. Verify the cumulative operation time of the fan with monitor U4-03, and verify the cumulative operation time of the fan maintenance timer with U4-04. If the cooling fan has exceeded its expected performance life or is damaged in any other way, follow the replacement instructions in the <i>Peripheral Devices & Options</i> chapter.
Fault detected in the internal cooling fan or magnetic contactor to the power supply.		<ul style="list-style-type: none"> Cycle power to the drive. If the fault continues to occur, replace the power board/gate drive board or the entire drive. Contact Yaskawa or a Yaskawa representative for instructions on replacing the power board/gate drive board.

Digital Operator Display		Fault Name
FbH	FbH	Excessive PID Feedback
Cause		Possible Solution
Parameters are set inappropriately		Check b5-36 and b5-37 settings.
Incorrect PID feedback wiring		Correct the wiring.
There is a problem with the feedback sensor		<ul style="list-style-type: none"> Check the sensor on the control side. Replace the sensor if damaged.

Digital Operator Display		Fault Name
FbL	FbL	PID Feedback Loss
Cause		Possible Solution
Parameters are set inappropriately		Check b5-13 and b5-14 settings.
Incorrect PID feedback wiring		Correct the wiring.
There is a problem with the feedback sensor		<ul style="list-style-type: none"> Check the sensor on the control side. Replace the sensor if damaged.

Digital Operator Display		Fault Name
GF	GF	Ground Fault
Cause		Possible Solution
Motor insulation is damaged		<ul style="list-style-type: none"> Check the insulation resistance of the motor. Replace the motor.
A damaged motor cable is creating a short circuit		<ul style="list-style-type: none"> Check the motor cable. Remove the short circuit and reapply power to the drive Check the resistance between the cable and the ground terminal ⊕. Replace the cable.
Excessive leakage current at the drive output		<ul style="list-style-type: none"> Reduce the carrier frequency. Reduce the amount of stray capacitance.

The drive started to run during a current offset fault or while coasting to a stop	<ul style="list-style-type: none"> The set value exceeds the allowable setting range while the drive automatically adjusts the current offset. This only happens when attempting to restart a PM motor that is coasting to stop. Set b3-01 to 1 to enable Speed Search at Start. Perform Speed Search 1 or 2 (H1-□□ = 61 or 62) via one of the external terminals. Note: Speed Searches 1 and 2 are the same when using OLV/PM.
Hardware problem	If the problem continues, replace the control board or the entire drive. Contact Yaskawa or a Yaskawa representative for instructions on replacing the control board.

Digital Operator Display		Fault Name
LF	LF	Output Phase Loss
Cause		Possible Solution
The output cable is disconnected		<ul style="list-style-type: none"> Check for wiring errors and properly connect the output cable. Correct the wiring.
The motor winding is damaged		<ul style="list-style-type: none"> Check the resistance between motor lines. Replace the motor if the winding is damaged.
The output terminal is loose		<ul style="list-style-type: none"> Apply the tightening torque specified in this manual to fasten the terminals. <i>Refer to Wire Gauges and Tightening Torque on page 89</i> for details.
The rated current of the motor being used is less than 5% of the drive rated current		Check the drive and motor capacities.
An output transistor is damaged		If the problem continues, replace the control board or the entire drive. Contact Yaskawa or a Yaskawa representative for instructions on replacing the control board.
A single-phase motor is being used		The drive cannot operate a single phase motor.

Digital Operator Display		Fault Name
LF2	LF2	Output Current Imbalance
Cause		Possible Solution
Phase loss has occurred on the output side of the drive		<ul style="list-style-type: none"> Check for faulty wiring or poor connections on the output side of the drive. Correct the wiring.
Terminal wires are loose on the output side of the drive		Apply the tightening torque specified in this manual to fasten the terminals. <i>Refer to Wire Gauges and Tightening Torque on page 89</i> for details.
The output circuit is damaged		If the problem continues, replace the control board or the entire drive. Contact Yaskawa or a Yaskawa representative for instructions on replacing the control board.
Motor impedance or motor phases are uneven		<ul style="list-style-type: none"> Measure the line-to-line resistance for each motor phase. Ensure all values match. Replace the motor.

Digital Operator Display		Fault Name
LF3 <1>	LF3	Power Unit Output Phase Loss 3
Cause		Possible Solution
The gate drive board in the power unit is damaged.		Cycle the power supply. <i>Refer to Diagnosing and Resetting Faults on page 386</i> for details. If the fault continues to occur, replace the gate drive board or the entire drive. Contact Yaskawa or a Yaskawa representative for instructions on replacing the gate drive board.
Cable to the current detection circuit in the power unit is damaged or not connected properly.		Check for incorrect wiring and correct any wiring mistakes.
Cable between the output rectifier and the power unit is loose or not connected.		Contact Yaskawa or your nearest sales representative for instructions.

<1> Detected in models 4A0930 and 4A1200.

Digital Operator Display		Fault Name
LSo <1>	LSo	LSo Fault
Cause		Possible Solution
		Pull-out has been detected at low speed.

6.4 Fault Detection

The incorrect motor code has been entered.	<ul style="list-style-type: none"> Enter the correct motor code for the PM motor being used into E5-01. For special-purpose motors, enter the correct data to all E5 parameters according to the test report provided for the motor.
The load is too heavy.	<ul style="list-style-type: none"> Reduce the load. Replace the drive with a larger model.
The drive incorrectly detected the position of the motor poles.	<ul style="list-style-type: none"> Make sure some external force is not rotating the motor at start. Enable Speed Search Selection at start. (b3-01 = 1). If the value displayed in U6-57 is lower than 819, then set the polarity judge current (n8-84) higher than the default value.
Values set to parameters L8-93, L8-94, and L8-95 are incorrect.	<ul style="list-style-type: none"> Increase the value set to L8-93. Increase the value set to L8-94. Increase the value set to L8-95.

<1> This function prevents continuous operation in reverse when using high frequency injection (n8-57 = 1) in AOLV/PM (A1-02 = 6) with a motor for which no motor code has been entered (it does not only prevent reverse operation). Set L8-93, L8-94, and L8-95 to low values within range of erroneous detection to quickly detect undesirable reverse operation.

Digital Operator Display		Fault Name
nSE	nSE	Node Setup Error
		A terminal assigned to the node setup function closed during run.
Cause		Possible Solution
The node setup terminal closed during run.		Stop the drive when using the node setup function.
A Run command was issued while the node setup function was active.		

Digital Operator Display		Fault Name
oC	oC	Overcurrent
		Drive sensors detected an output current greater than the specified overcurrent level.
Cause		Possible Solution
The motor has been damaged due to overheating or the motor insulation is damaged		<ul style="list-style-type: none"> Check the insulation resistance. Replace the motor.
One of the motor cables has shorted out or there is a grounding problem		<ul style="list-style-type: none"> Check the motor cables. Remove the short circuit and reapply power to the drive. Check the resistance between the motor cables and the ground terminal ⊕. Replace damaged cables.
The load is too heavy		<ul style="list-style-type: none"> Measure the current flowing into the motor. Replace the drive with a larger capacity drive if the current value exceeds the rated current. Determine if there is sudden fluctuation in the current level. Reduce the load to avoid sudden changes in the current level or switch to a larger drive.
The acceleration or deceleration times are too short		Calculate the torque needed during acceleration relative to the load inertia and the specified acceleration time. If it is not possible to set the proper amount of torque, make the following changes: <ul style="list-style-type: none"> Increase the acceleration time (C1-01, C1-03, C1-05, C1-07) Increase the S-curve characteristics (C2-01 through C2-04) Increase the capacity of the drive.
The drive is attempting to operate a specialized motor or a motor larger than the maximum size allowed		<ul style="list-style-type: none"> Check the motor capacity. Ensure that the rated capacity of the drive is greater than or equal to the capacity rating found on the motor nameplate.
Magnetic contactor (MC) on the output side of the drive has turned on or off		Set up the operation sequence so the MC does not trip while the drive is outputting current.
V/f setting is not operating as expected		<ul style="list-style-type: none"> Check the ratios between the voltage and frequency. Set parameters E1-04 through E1-10 appropriately (E3-04 through E3-10 for motor 2). Lower the voltage if it is too high relative to the frequency.
Excessive torque compensation		<ul style="list-style-type: none"> Check the amount of torque compensation. Reduce the torque compensation gain (C4-01) until there is no speed loss and less current.
Drive fails to operate properly due to noise interference		<ul style="list-style-type: none"> Review the possible solutions provided for handling noise interference. Review the section on handling noise interference on page 393 and check the control circuit lines, main circuit lines, and ground wiring.

Overexcitation gain is set too high	<ul style="list-style-type: none"> Check if the fault occurs simultaneously with overexcitation function operation. Consider motor flux saturation and reduce the value of n3-13 (Overexcitation Deceleration Gain).
Run command was applied while motor was coasting	<ul style="list-style-type: none"> Set b3-01 to 1 to enable Speed Search at Start. Program the Speed Search command input through one of the multi-function contact input terminals (H1-□□ = 61 or 62).
The wrong motor code has been entered for OLV/PM (Yaskawa motors only) or the motor data are wrong	<ul style="list-style-type: none"> Enter the correct motor code to E5-01. Set E5-01 to FFFF if using a non-Yaskawa PM motor. Set the correct motor data to the E5-□□ parameters or perform Auto-Tuning.
The motor control method and motor do not match	<ul style="list-style-type: none"> Check the control mode. For IM motors, set A1-02 to 0, 1, 2, or 3. For PM motors, set A1-02 to 5, 6, or 7.
The rated output current of the drive is too small	Use a larger drive.

Digital Operator Display		Fault Name
<i>oFR00</i>	oFA00	Option Card Connection Error at Option Port CN5-A
Cause		Possible Solution
The option card installed into port CN5-A is incompatible with the drive		Check if the drive supports the option card to be installed. Contact Yaskawa for assistance.
A PG option card is connected to option port CN5-A		PG option cards are supported by option ports CN5-B and CN5-C only. Connect the PG option card to the correct option port.

Digital Operator Display		Fault Name
<i>oFR01</i>	oFA01	Option Card Fault at Option Port CN5-A
Cause		Possible Solution
The option card connection to port CN5-A is faulty		<ul style="list-style-type: none"> Turn off the power and reconnect the option card. Check if the option card is properly plugged into the option port. Make sure the card is fixed properly. If the option is not a communication option card, try to use the card in a different option port. If the option card works properly in a different option port, CN5-A is damaged, and the drive requires replacement. If the error persists (oFb01 or oFC01 occur), replace the option card.

Digital Operator Display		Fault Name
<i>oFR03 to oFR06</i>	oFA03 to oFA06	Option Card Error Occurred at Option Port CN5-A
<i>oFR10, oFR11</i>	oFA10, oFA11	
<i>oFR12 to oFR17</i>	oFA12 to oFA17	Option Card Connection Error (CN5-A)
<i>oFR30 to oFR43</i>	oFA30 to oFA43	Communication Option Card Connection Error (CN5-A)
Cause		Possible Solution
Option card or hardware is damaged		<ul style="list-style-type: none"> Cycle power to the drive. If the problem continues, replace the control board or the entire drive. Contact Yaskawa or a Yaskawa representative for instructions on replacing the control board.

Digital Operator Display		Fault Name
<i>oFb00</i>	oFb00	Option Card Fault at Option Port CN5-B
Cause		Possible Solution
The option card installed into port CN5-B is incompatible with the drive		Make sure the drive supports the option card to be installed. Contact Yaskawa for assistance.
A communication option card has been installed in option port CN5-B		Communication option cards are only supported by option port CN5-A. It is not possible to install more than one communication option.

Digital Operator Display		Fault Name
<i>oFb01</i>	oFb01	Option Card Fault at Option Port CN5-B
Cause		Possible Solution
		Option not properly connected

6.4 Fault Detection

The option card connection to port CN5-B is faulty	<ul style="list-style-type: none"> • Turn off the power and reconnect the option card. • Check if the option card is properly plugged into the option port. Make sure the card is fixed properly. • Try to use the card in a different option port (in case of a PG option, use port CN5-C). If the option card works properly in a different option port, CN5-B is damaged, and the drive requires replacement. If the error persists (oFA01 or oFC01 occur), replace the option card.
--	--

Digital Operator Display		Fault Name
oFb02	oFb02	Option Card Fault at Option Port CN5-B
Cause		Possible Solution
An option card of the same type is already installed in option port CN5-A		Except for PG options, only one of each option card type can only be installed simultaneously. Make sure only one type of option card is connected.
An input option card is already installed in option port CN5-A		Install a communication option, a digital input option, or an analog input option. More than one of the same type of card cannot be installed simultaneously.

Digital Operator Display		Fault Name
oFb03 to oFb11	oFb03 to oFb11	Option card error occurred at Option Port CN5-B
oFb12 to oFb17	oFb12 to oFb17	
Cause		Possible Solution
Option card or hardware is damaged		<ul style="list-style-type: none"> • Cycle power to the drive. • If the problem continues, replace the control board or the entire drive. Contact Yaskawa or a Yaskawa representative for instructions on replacing the control board.

Digital Operator Display		Fault Name
oFC00	oFC00	Option Card Connection Error at Option Port CN5-C
Cause		Possible Solution
The option card installed into port CN5-C is incompatible with the drive		Confirm that the drive supports the option card to be installed. Contact Yaskawa for assistance.
A communication option card has been installed in option port CN5-C		Communication option cards are only supported by option port CN5-A. It is not possible to install more than one communication option.

Digital Operator Display		Fault Name
oFC01	oFC01	Option Card Fault at Option Port CN5-C
Cause		Possible Solution
The option card connection to port CN5-C is faulty.		<ul style="list-style-type: none"> • Turn the power off and reconnect the option card. • Check if the option card is properly plugged into the option port. Make sure the card is fixed properly. • Try to use the card in a different option port (in case of a PG option, use port CN5-B). If the option card works properly in a different option port, CN5-C is damaged, and the drive requires replacement. If the error persists (oFA01 or oFb01 occur), replace the option card.

Digital Operator Display		Fault Name
oFC02	oFC02	Option Card Fault at Option Port CN5-C
Cause		Possible Solution
An option card of the same type is already installed in option port CN5-A or CN5-B.		Except for PG options, only one of each option card type can only be installed simultaneously. Make sure only one type of option card is connected.
An input option card is already installed in option port CN5-A or CN5-B.		Install a communication option, a digital input option, or an analog input option. More than one of the same type of card cannot be installed simultaneously.
Three PG option boards are installed.		A maximum of two PG option boards can be used simultaneously. Remove the PG option board installed into option port CN5-A.

Digital Operator Display		Fault Name
oFC03 to oFC11	oFC03 to oFC11	Option Card Error Occurred at Option Port CN5-C
oFC12 to oFC17	oFC12 to oFC17	
Cause		Possible Solution

Option card or hardware is damaged	<ul style="list-style-type: none"> • Cycle power to the drive. • If the problem continues, replace the control board or the entire drive. Contact Yaskawa or a Yaskawa representative for instructions on replacing the control board.
------------------------------------	--

Digital Operator Display		Fault Name
oFL50 to oFL55	oFC50 to oFC55	Option Card Error Occurred at Option Port CN5-C
Cause		Possible Solution
Option card or hardware is damaged		Refer to the option manual for details.

Digital Operator Display		Fault Name
oH	oH	Heatsink Overheat
		The heatsink temperature exceeded the overheat pre-alarm level set to L8-02. The default value for L8-02 is determined by drive capacity (o2-04).
Cause		Possible Solution
Surrounding temperature is too high		<ul style="list-style-type: none"> • Check the temperature surrounding the drive. Verify temperature is within drive specifications. • Improve the air circulation within the enclosure panel. • Install a fan or air conditioner to cool the surrounding area. • Remove anything near the drive that might be producing excessive heat.
Load is too heavy		<ul style="list-style-type: none"> • Measure the output current. • Decrease the load. • Lower the carrier frequency (C6-02).
Internal cooling fan is stopped		<ul style="list-style-type: none"> • Replace the cooling fan. <i>Refer to Cooling Fan Replacement: 2A0018 to 2A0081, 4A0007 to 4A0044, and 5A0006 to 5A0032 on page 409.</i> • After replacing the cooling fan, set parameter o4-03 to 0 to reset the cooling fan maintenance.

Digital Operator Display		Fault Name
oH1	oH1	Overheat 1 (Heatsink Overheat)
		The heatsink temperature exceeded the drive overheat level. Overheat level is determined by drive capacity (o2-04).
Cause		Possible Solution
Surrounding temperature is too high		<ul style="list-style-type: none"> • Check the temperature surrounding the drive. • Improve the air circulation within the enclosure panel. • Install a fan or air conditioner to cool the surrounding area. • Remove anything near the drive that might be producing excessive heat.
Load is too heavy		<ul style="list-style-type: none"> • Measure the output current. • Lower the carrier frequency (C6-02). • Reduce the load.

Digital Operator Display		Fault Name
oH3	oH3	Motor Overheat Alarm (PTC Input)
		<ul style="list-style-type: none"> • The motor overheat signal to analog input terminal A1, A2, or A3 exceeded the alarm detection level. • Detection requires setting multi-function analog inputs H3-02, H3-10, or H3-06 to E.
Cause		Possible Solution
Motor has overheated		<ul style="list-style-type: none"> • Check the size of the load, the accel/decel times, and the cycle times. • Decrease the load. • Increase the acceleration and deceleration times (C1-01 through C1-08).
		<ul style="list-style-type: none"> • Adjust the preset V/f pattern (E1-04 through E1-10) by reducing E1-08 and E1-10. • Do not set E1-08 and E1-10 too low. This reduces load tolerance at low speeds.
		<ul style="list-style-type: none"> • Check the motor rated current. • Enter the motor rated current to parameter E2-01 as indicated on the motor nameplate. • Ensure the motor cooling system is operating normally. • Repair or replace the motor cooling system.

Digital Operator Display		Fault Name
oH4	oH4	Motor Overheat Fault (PTC Input)
		<ul style="list-style-type: none"> • The motor overheat signal to analog input terminal A1, A2, or A3 exceeded the fault detection level. • Detection requires setting multi-function analog inputs H3-02, H3-10, or H3-06 to E.

6.4 Fault Detection

Cause	Possible Solution
Motor has overheated	<ul style="list-style-type: none"> Check the size of the load, the accel/decel times, and the cycle times. Decrease the load. Increase the acceleration and deceleration times (C1-01 through C1-08).
	<ul style="list-style-type: none"> Adjust the preset V/f pattern (E1-04 through E1-10) by reducing E1-08 and E1-10. Do not set E1-08 and E1-10 too low. This reduces load tolerance at low speeds.
	<ul style="list-style-type: none"> Check the motor rated current. Enter the motor rated current to parameter E2-01 as indicated on the motor nameplate. Ensure the motor cooling system is operating normally. Repair or replace the motor cooling system.

Digital Operator Display		Fault Name
oH5 <1>	oH5	Motor Overheat (NTC Input)
		The motor temperature exceeded the level set to L1-16 (or L1-18 for motor 2)
Cause		Possible Solution
Motor has overheated		<ul style="list-style-type: none"> Reduce the load. Check the ambient temperature.

<1> Detected in models 4A0930 and 4A1200.

Digital Operator Display		Fault Name
oL1	oL1	Motor Overload
		The electronic motor overload protection tripped
Cause		Possible Solution
Load is too heavy		Reduce the load.
Cycle times are too short during acceleration and deceleration		Increase the acceleration and deceleration times (C1-01 through C1-08).
A general-purpose motor is driven below the rated speed with a high load		<ul style="list-style-type: none"> Reduce the load. Increase the speed. If the motor is supposed to operate at low speeds, either increase the motor capacity or use a motor specifically designed to operate in the desired speed range.
The output voltage is too high		<ul style="list-style-type: none"> Adjust the user-set V/f pattern (E1-04 through E1-10) by reducing E1-08 and E1-10. Do not set E1-08 and E1-10 too low. This reduces load tolerance at low speeds.
The wrong motor rated current is set to E2-01		<ul style="list-style-type: none"> Check the motor-rated current. Enter the motor rated current to parameter E2-01 as indicated on the motor nameplate.
The base frequency is set incorrectly		<ul style="list-style-type: none"> Check the rated frequency indicated on the motor nameplate. Enter the rated frequency to E1-06 (Base Frequency).
Multiple motors are running off the same drive		Set L1-01 to 0 to disable the motor protection function and then install a thermal relay to each motor.
The electrical thermal protection characteristics and motor overload characteristics do not match		<ul style="list-style-type: none"> Check the motor characteristics. Correct the type of motor protection that has been selected (L1-01). Install an external thermal relay.
The electrical thermal relay is operating at the wrong level		<ul style="list-style-type: none"> Check the current rating listed on the motor nameplate. Check the value set for the motor rated current (E2-01).
Motor overheated by overexcitation operation		<ul style="list-style-type: none"> Overexcitation increases the motor loss and the motor temperature. Excessive duration of overexcitation may cause motor damage. Prevent excessive overexcitation operation or apply proper cooling to the motor. Reduce the excitation deceleration gain (n3-13). Set L3-04 (Stall Prevention during Deceleration) to a value other than 4.
Parameters related to Speed Search are set incorrectly		<ul style="list-style-type: none"> Check values set to Speed Search related parameters. Adjust the Speed Search current and Speed Search deceleration times (b3-02 and b3-03 respectively). After Auto-Tuning, set b3-24 to 1 to enable Speed Estimation Speed Search.
Output current fluctuation due to power supply loss		Check the power supply for phase loss.

Digital Operator Display		Fault Name
oL2	oL2	Drive Overload
		The thermal sensor of the drive triggered overload protection.

Cause	Possible Solution
Load is too heavy	Reduce the load.
Acceleration or deceleration time is too short	Increase the settings for the acceleration and deceleration times (C1-01 through C1-08).
The output voltage is too high	<ul style="list-style-type: none"> Adjust the preset V/f pattern (E1-04 through E1-10) by reducing E1-08 and E1-10. Do not lower E1-08 and E1-10 excessively. This reduces load tolerance at low speeds.
Drive capacity is too small	Replace the drive with a larger model.
Overload occurred when operating at low speeds	<ul style="list-style-type: none"> Reduce the load when operating at low speeds. Replace the drive with a model that is one frame size larger. Lower the carrier frequency (C6-02).
Excessive torque compensation	Reduce the torque compensation gain in parameter C4-01 until there is no speed loss but less current.
Parameters related to Speed Search are set incorrectly	<ul style="list-style-type: none"> Check the settings for all Speed Search related parameters. Adjust the current used during Speed Search (b3-03) and the Speed Search deceleration time (b3-02). After Auto-Tuning, set b3-24 to 1 to enable Speed Estimation Speed Search.
Output current fluctuation due to input phase loss	Check the power supply for phase loss.

Digital Operator Display		Fault Name
oL3	oL3	Overtorque Detection 1
		The current has exceeded the value set for torque detection (L6-02) for longer than the allowable time (L6-03).
Cause		Possible Solution
Parameter settings are not appropriate for the load		Check L6-02 and L6-03 settings.
Fault on the machine side (e.g., machine is locked up)		Check the status of the load. Remove the cause of the fault.

Digital Operator Display		Fault Name
oL4	oL4	Overtorque Detection 2
		The current has exceeded the value set for Overtorque Detection 2 (L6-05) for longer than the allowable time (L6-06).
Cause		Possible Solution
Parameter settings are not appropriate for the load		Check the settings of parameters L6-05 and L6-06.

Digital Operator Display		Fault Name
oL5	oL5	Mechanical Weakening Detection 1
		Overtorque occurred, matching the conditions specified in L6-08.
Cause		Possible Solution
Overtorque triggered mechanical weakening detection level set to L6-08		Identify the cause of mechanical weakening.

Digital Operator Display		Fault Name
oL7	oL7	High Slip Braking oL
		The output frequency stayed constant for longer than the time set to n3-04 during High Slip Braking.
Cause		Possible Solution
Excessive load inertia	<ul style="list-style-type: none"> Reduce deceleration times in parameters C1-02, C1-04, C1-06, and C1-08 for applications that do not use High Slip Braking. Use a braking resistor to shorten deceleration time. 	
Motor is driven by the load		
Something on the load side is restricting deceleration		
The overload time during High Slip Braking is too short	<ul style="list-style-type: none"> Increase parameter n3-04 (High-slip Braking Overload Time). Install a thermal relay and increase the setting of n3-04 to maximum value. 	

6.4 Fault Detection

Digital Operator Display		Fault Name
oPr	oPr	External Digital Operator Connection Fault
		The external operator has been disconnected from the drive. Note: An oPr fault will occur when all of the following conditions are true: • Output is interrupted when the operator is disconnected (o2-06 = 1). • The Run command is assigned to the operator (b1-02 = 0 and LOCAL has been selected).
Cause		Possible Solution
External operator is not properly connected to the drive		<ul style="list-style-type: none"> • Check the connection between the operator and the drive. • Replace the cable if damaged. • Turn off the drive input power and disconnect the operator. Reconnect the operator and reapply drive input power.

Digital Operator Display		Fault Name
oS	oS	Overspeed
		The motor speed feedback exceeded the F1-08 setting.
Cause		Possible Solution
Overshoot is occurring		<ul style="list-style-type: none"> • Reduce the C5-01, Speed Control Proportional Gain 1, setting and increase the C5-02, Speed Control Integral Time 1, setting. • If using Closed Loop Vector mode, enable Feed Forward and perform Inertia Auto-Tuning.
Incorrect speed feedback scaling if terminal RP is used as speed feedback input in V/f control		<ul style="list-style-type: none"> • Set H6-02 to the value of the speed feedback signal frequency when the motor runs at the maximum speed. • Adjust the input signal using parameters H6-03 through H6-05.
Incorrect number of PG pulses has been set		Check and correct parameter F1-01.
Inappropriate parameter settings		Check the setting for the overspeed detection level and the overspeed detection time (F1-08 and F1-09).

Digital Operator Display		Fault Name
ov	ov	Overvoltage
		Voltage in the DC bus has exceeded the overvoltage detection level. <ul style="list-style-type: none"> • For 200 V class drives: approximately 410 V • For 400 V class drives: approximately 820 V (740 V when E1-01 is less than 400) • For 600 V class drives: approximately 1040 V
Cause		Possible Solution
Deceleration time is too short and regenerative energy is flowing from the motor into the drive		<ul style="list-style-type: none"> • Increase the deceleration time (C1-02, C1-04, C1-06, C1-08). • Install a dynamic braking resistor or a dynamic braking resistor unit. • Set L3-04 to 1 to enable stall prevention during deceleration. Stall Prevention is enabled as the default setting.
Fast acceleration time causes the motor to overshoot the speed reference		<ul style="list-style-type: none"> • Check if sudden drive acceleration triggers an overvoltage alarm. • Increase the acceleration time. • Use longer S-curve acceleration and deceleration times. • Enable the Overvoltage Suppression function (L3-11 = 1). • Lengthen the S-curve at acceleration end.
Excessive braking load		The braking torque was too high, causing regenerative energy to charge the DC bus. Reduce the braking torque, use a dynamic braking option, or lengthen decel time.
Surge voltage entering from the drive input power		Install a DC link choke. Note: Voltage surge can result from a thyristor convertor and phase advancing capacitor using the same input power supply.
Ground fault in the output circuit causes the DC bus capacitor to overcharge		<ul style="list-style-type: none"> • Check the motor wiring for ground faults. • Correct grounding shorts and reapply power.
Improper parameters related to Speed Search (including Speed Search after a momentary power loss and after a fault restart)		<ul style="list-style-type: none"> • Check the settings for Speed Search-related parameters. • Enable Speed Search restart function (b3-19 greater than or equal to 1 to 10). • Adjust the current level during Speed Search and the deceleration time (b3-02 and b3-03 respectively). • Perform Stationary Auto-Tuning for line-to-line resistance and then set b3-14 to 1 to enable Speed Estimation Speed Search.
Drive input power voltage is too high		<ul style="list-style-type: none"> • Check the voltage. • Lower drive input power voltage within the limits listed in the specifications.
The braking transistor or braking resistor are wired incorrectly		<ul style="list-style-type: none"> • Check braking transistor and braking resistor wiring for errors. • Properly rewire the braking resistor device.

PG cable is disconnected	Reconnect the cable.
PG cable wiring is wrong	Correct the wiring.
Noise interference along the PG encoder wiring	Separate the wiring from the source of the noise. Often, this is the output lines from the drive.
Drive fails to operate properly due to noise interference	<ul style="list-style-type: none"> Review the list of possible solutions provided for controlling noise. Review the section on handling noise interference on page 393 and check the control circuit lines, main circuit lines, and ground wiring.
Load inertia is set incorrectly	<ul style="list-style-type: none"> Check the load inertia settings when using KEB, overvoltage suppression, or Stall Prevention during deceleration. Adjust the load inertia ratio in L3-25 to better match the load.
Braking function is being used in OLV/PM	Connect a braking resistor.
Motor hunting occurs	<ul style="list-style-type: none"> Adjust the parameters that control hunting. Set the gain for Hunting Prevention (n1-02). Adjust the AFR time constant (n2-02 and n2-03). Adjust the speed feedback detection suppression gain for PM motors (n8-45) and the time constant for pull-in current (n8-47).

Digital Operator Display		Fault Name
$P\bar{F}$	PF	Input Phase Loss
		Drive input power has an open phase or has a large imbalance of voltage between phases. Detected when L8-05 is set 1 (enabled).
Cause		Possible Solution
There is phase loss in the drive input power		<ul style="list-style-type: none"> Check for wiring errors in the main circuit drive input power. Correct the wiring.
There is loose wiring in the drive input power terminals		<ul style="list-style-type: none"> Ensure the terminals are tightened properly. Apply the tightening torque as specified in this manual. <i>Refer to Wire Gauges and Tightening Torque on page 89</i> for details.
There is excessive fluctuation in the drive input power voltage		<ul style="list-style-type: none"> Check the voltage from the drive input power. Review the possible solutions for stabilizing the drive input power.
There is poor balance between voltage phases		Stabilize drive input power or disable phase loss detection.
The main circuit capacitors are worn		<ul style="list-style-type: none"> Check the maintenance time for the capacitors (U4-05). Replace the capacitor if U4-05 is greater than 90%. For instructions on replacing the capacitor, contact Yaskawa or a Yaskawa representative. <p>Check for problems with the drive input power. If drive input power appears normal but the alarm continues to occur, replace either the control board or the entire drive. For instructions on replacing the control board, contact Yaskawa or a Yaskawa representative.</p>

Digital Operator Display		Fault Name
$P\bar{G}o$	PGo	PG Disconnect (for any control modes using a PG option card)
		No PG pulses are received for longer than the time set to F1-14.
Cause		Possible Solution
PG cable is disconnected		Reconnect the cable.
PG cable wiring is wrong		Correct the wiring.
PG has no power		Check the power line to the PG encoder.
PG encoder brake is clamped shut		Ensure the motor brake releases properly.

Digital Operator Display		Fault Name
$P\bar{G}oH$	PGoH	PG Hardware Fault (detected when using a PG-X3 option card)
		PG cable is not connected properly.
Cause		Possible Solution
PG cable is disconnected		Reconnect the cable and check the setting of F1-20.

Digital Operator Display		Fault Name
$r\bar{F}$	rF	Braking Resistor Fault
		The resistance of the braking resistor is too low.
Cause		Possible Solution

6.4 Fault Detection

The proper braking resistor option has not been installed	Select a braking resistor option that it fits the drive braking transistor specification.
A regenerative converter, regenerative unit, or braking unit is being used	Set L8-55 to 0 to disable the braking transistor protection selection.

Digital Operator Display		Fault Name
rH	rH	Braking Resistor Overheat
		Braking resistor protection was triggered. Fault detection is enabled when L8-01 = 1 (disabled as a default).
Cause		Possible Solution
Deceleration time is too short and excessive regenerative energy is flowing back into the drive		<ul style="list-style-type: none"> • Check the load, deceleration time, and speed. • Reduce the load inertia. • Increase the deceleration times (C1-01 to C1-08). • Replace the dynamic braking option with a larger device that can handle the power that is discharged.
The duty cycle is too high		Check the duty cycle. Maximum of 3% duty cycle is available when L8-01 = 1.
Excessive braking inertia		Recalculate braking load and braking power. Reduce the braking load by adjusting braking resistor settings.
The braking operation duty cycle is too high		Check the braking operation duty cycle. Braking resistor protection for ERF-type braking resistors (L8-01 = 1) allows a braking duty cycle of maximum 3%.
The proper braking resistor has not been installed		<ul style="list-style-type: none"> • Check the specifications and conditions for the braking resistor device. • Select the optimal braking resistor.
<p>Note: The magnitude of the braking load trips the braking resistor overheat alarm, NOT the surface temperature. Using the braking resistor more frequently than its rating permits will trip the alarm even when the braking resistor surface is not very hot.</p>		

Digital Operator Display		Fault Name
rr	rr	Dynamic Braking Transistor
		The built-in dynamic braking transistor failed.
Cause		Possible Solution
The braking transistor is damaged		<ul style="list-style-type: none"> • Cycle power to the drive and check for reoccurrence of the fault.
The control circuit is damaged		<ul style="list-style-type: none"> • Replace either the control board or the entire drive. For instructions on replacing the control board, contact Yaskawa or a Yaskawa representative.

Digital Operator Display		Fault Name
SC </>	SC	IGBT Short Circuit or Ground Fault
		Possible Solution
IGBT fault		<ul style="list-style-type: none"> • Check motor wiring.
IGBT short circuit detection circuit fault		<ul style="list-style-type: none"> • Turn off the power supply, then turn it on. If the problem continues, contact your Yaskawa representative or the nearest Yaskawa sales office.
The drive is damaged		<ul style="list-style-type: none"> • Check the drive output side short circuit for a broken output transistor B1 and U/T1, V/T2, W/T3 – and U/T1, V/T2, W/T3 • Contact your Yaskawa representative or nearest Yaskawa sales office.

<1> Available in drive software versions 1015 and later.

Digital Operator Display		Fault Name
SEr	SEr	Too Many Speed Search Restarts
		The number of Speed Search restarts exceeded the value set to b3-19.
Cause		Possible Solution
Parameters related to Speed Search are set to the wrong values		<ul style="list-style-type: none"> • Reduce the detection compensation gain during Speed Search (b3-10). • Increase the current level when attempting Speed Search (b3-17). • Increase the detection time during Speed Search (b3-18). • Repeat Auto-Tuning.
The motor is coasting in the opposite direction of the Run command		Set b3-14 to 1 to enable Bi-Directional Speed Search.

Digital Operator Display		Fault Name
STo	STo	Motor Pull Out or Step Out Detection
		Motor pull out or step out has occurred. Motor has exceeded its pull-out torque.
Cause		Possible Solution
The wrong motor code is set (Yaskawa motors only)		<ul style="list-style-type: none"> Enter the correct motor code for the PM being used into E5-01. For special-purpose motors, enter the correct data to all E5 parameters according to the test report provided for the motor.
Load is too heavy		<ul style="list-style-type: none"> Increase the load inertia for PM motor (n8-55). Increase the pull-in current during accel/decel (n8-51). Reduce the load. Increase the motor or drive capacity.
Load inertia is too heavy		Increase the load inertia for PM motor (n8-55).
Acceleration and deceleration times are too short		<ul style="list-style-type: none"> Increase the acceleration and deceleration times (C1-01 through C1-08). Increase the S-curve acceleration and deceleration times (C2-01).
Speed response is too slow		Increase the load inertia for PM motor (n8-55).

Digital Operator Display		Fault Name
SvE	SvE	Zero Servo Fault
		Position deviation during zero servo.
Cause		Possible Solution
Torque limit is set too low		Set the torque limit to an appropriate value using parameters L7-01 to L7-04.
Excessive load torque		Reduce the amount of load torque.
Noise interference along PG encoder wiring		Check the PG signal for noise interference.

Digital Operator Display		Fault Name
THo <1>	THo	Thermistor Disconnect
		The thermistor that detects motor temperature has become disconnected.
Cause		Possible Solution
The motor thermistor is not connected properly.		Check the thermistor wiring.

<1> Detected in models 4A0930 and 4A1200.

Digital Operator Display		Fault Name
UL3	UL3	Undertorque Detection 1
		The current has fallen below the minimum value set for torque detection (L6-02) for longer than the allowable time (L6-03).
Cause		Possible Solution
Parameter settings are not appropriate for the load		Check the settings of parameters L6-02 and L6-03.
There is a fault on the machine side		Check the load for any problems.

Digital Operator Display		Fault Name
UL4	UL4	Undertorque Detection 2
		The current has fallen below the minimum value set for torque detection (L6-05) for longer than the allowable time (L6-06).
Cause		Possible Solution
Parameter settings are not appropriate for the load		Check L6-05 and L6-06 settings
There is a fault on the machine side		Check the load for any problems.

Digital Operator Display		Fault Name
UL5	UL5	Mechanical Weakening Detection 2
		The operation conditions matched the conditions set to L6-08.
Cause		Possible Solution
Undertorque was detected and matched the conditions for mechanical loss detection set to L6-08		Check the load side for any problems.

6.4 Fault Detection

Digital Operator Display		Fault Name
$UnbC$ <I>	UnbC	Current Unbalance Current flow has become unbalanced.
Cause		Possible Solution
The internal current sensor has detected a current unbalance situation.		<ul style="list-style-type: none"> • Check wiring • Check for damaged transistors. • Check for short circuits or grounding problems on the connected motor.

<I> Detected in models 4A0930 and 4A1200.

Digital Operator Display		Fault Name
$Uv1$	Uv1	DC Bus Undervoltage One of the following conditions occurred while the drive was running: <ul style="list-style-type: none"> • Voltage in the DC bus fell below the undervoltage detection level (L2-05). • For 200 V class drives: approximately 190 V • For 400 V class drives: approximately 380 V (350 V when E1-01 is less than 400) • For 600 V class drives: approximately 475 V The fault is output only if L2-01 is set to 0 or 1 and the DC bus voltage has fallen below the level set to L2-05 for longer than the time set to L2-02.
Cause		Possible Solution
Input power phase loss		<ul style="list-style-type: none"> • The main circuit drive input power is wired incorrectly. • Correct the wiring.
One of the drive input power wiring terminals is loose		<ul style="list-style-type: none"> • Ensure there are no loose terminals. • Apply the tightening torque specified in this manual to fasten the terminals. <i>Refer to Wire Gauges and Tightening Torque on page 89</i> for details.
There is a problem with the voltage from the drive input power		<ul style="list-style-type: none"> • Check the voltage. • Correct the voltage to be within the range listed in drive input power specifications. • If there is no problem with the power supply to the main circuit, check for problems with the main circuit magnetic contactor.
The power has been interrupted		Correct the drive input power.
The main circuit capacitors are worn		<ul style="list-style-type: none"> • Check the maintenance time for the capacitors (U4-05). • Replace either the control board or the entire drive if U4-05 exceeds 90%. For instructions on replacing the control board, contact Yaskawa or a Yaskawa representative.
The relay or contactor on the soft-charge bypass circuit is damaged		<ul style="list-style-type: none"> • Cycle power to the drive and see if the fault reoccurs. • If the problem continues, replace either the control board or the entire drive. For instructions on replacing the control board, contact Yaskawa or a Yaskawa representative. • Check monitor U4-06 for the performance life of the soft-charge bypass. • Replace either the control board or the entire drive if U4-06 exceeds 90%. For instructions on replacing the control board, contact Yaskawa or a Yaskawa representative.

Digital Operator Display		Fault Name
$Uv2$	Uv2	Control Power Supply Voltage Fault Voltage is too low for the control drive input power.
Cause		Possible Solution
In drive models 2A0004 to 2A0056 or 4A0002 to 4A0031, L2-02 was changed from its default value without installing a Momentary Power Loss Ride-Thru unit		Correct the setting to L2-02 or install an optional Momentary Power Loss Ride-Thru unit.
Control power supply wiring is damaged		<ul style="list-style-type: none"> • Cycle power to the drive. Check if the fault reoccurs. • If the problem continues, replace the control board, the entire drive, or the control power supply. For instructions on replacing the control board, contact Yaskawa or a Yaskawa representative.
Internal circuitry is damaged		<ul style="list-style-type: none"> • Cycle power to the drive. Check if the fault reoccurs. • If the problem continues, replace either the control board or the entire drive. For instructions on replacing the control board, contact Yaskawa or a Yaskawa representative.

Digital Operator Display		Fault Name
$Uv3$	Uv3	Undervoltage 3 (Soft-Charge Bypass Circuit Fault) The soft-charge bypass circuit failed.
Cause		Possible Solution

The relay or contactor on the soft-charge bypass circuit is damaged	<ul style="list-style-type: none"> • Cycle power to the drive and see if the fault reoccurs. • If the problem continues, replace either the control board or the entire drive. For instructions on replacing the control board, contact Yaskawa or a Yaskawa representative. • Check monitor U4-06 for the performance life of the soft-charge bypass. • Replace either the control board or the entire drive if U4-06 exceeds 90%. For instructions on replacing the control board, contact Yaskawa or a Yaskawa representative.
---	---

Digital Operator Display		Fault Name
Uv4 <I>	Uv4	Gate Drive Board Undervoltage
		Voltage drop in the gate drive board circuit
Cause		Possible Solution
Not enough power is being supplied to the gate drive board.		<ul style="list-style-type: none"> • Cycle power to the drive and see if the fault reoccurs. <i>Refer to Diagnosing and Resetting Faults on page 386</i> for details. • If the problem continues, replace either the gate drive board or the entire drive. For instructions on replacing the gate drive board, contact Yaskawa or a Yaskawa representative.

<I> Detected in models 4A0930 and 4A1200.

Digital Operator Display		Fault Name
voF	voF	Output Voltage Detection Fault
		Problem detected with the voltage on the output side of the drive.
Cause		Possible Solution
Hardware is damaged. Internal drive module MC / FAN overheat protection circuit board is due to abnormal ambient operating power.		<ul style="list-style-type: none"> • Lower ambient temperature. • Replace the control board or the entire drive. For instructions on replacing the control board, contact Yaskawa or a Yaskawa representative.

6.5 Alarm Detection

◆ Alarm Codes, Causes, and Possible Solutions

Alarms are drive protection functions that do not necessarily cause the drive to stop. After removing the cause of an alarm, the drive will return to the same status it was before the alarm occurred.

When an alarm has been triggered, the ALM light on the digital operator display blinks and the alarm code display flashes. If a multi-function output is set for an alarm (H2-□□ = 10), that output terminal will be triggered.

Note: If a multi-function output is set to close when an alarm occurs (H2-□□ = 10), it will also close when maintenance periods are reached, triggering alarms LT-1 through LT-4 (triggered only if H2-□□ = 2F).

Table 6.15 Alarm Codes, Causes, and Possible Solutions

Digital Operator Display		Minor Fault Name
<i>AEr</i>	AEr	Communication Option Station Number Setting Error (CC-Link, CANopen, MECHATROLINK-II)
Cause		Possible Solutions
Station number is set outside the possible setting range.		<ul style="list-style-type: none"> Set parameter F6-10 to the proper value when using a CC-Link option. Set parameter F6-35 to the proper value when using a CANopen option.
Digital Operator Display		Minor Fault Name
<i>bb</i>	bb	Baseblock
Cause		Possible Solutions
External baseblock signal was entered via one of the multi-function input terminals (S1 to S8).		Check external sequence and baseblock signal input timing.
Digital Operator Display		Minor Fault Name
<i>boL</i>	boL	Braking Transistor Overload Fault
Cause		Possible Solutions
The proper braking resistor has not been installed.		Select the proper braking resistor.
Digital Operator Display		Minor Fault Name
<i>bUS</i>	bUS	Option Communication Error
Cause		Possible Solutions
Connection is broken or master controller stopped communicating.		<ul style="list-style-type: none"> Check for faulty wiring. Correct the wiring. Check for disconnected cables and short circuits. Repair as needed.
Option is damaged.		If there are no problems with the wiring and the fault continues to occur, replace the option.
The option is not properly connected to the drive.		<ul style="list-style-type: none"> The connector pins on the option are not properly lined up with the connector pins on the drive. Reinstall the option.
A data error occurred due to noise.		<ul style="list-style-type: none"> Check options available to minimize the effects of noise. Take steps to counteract noise in the control circuit wiring, main circuit lines and ground wiring. Try to reduce noise on the controller side. Use surge absorbers on magnetic contactors or other equipment causing the disturbance. Use recommended cables or some other type of shielded line. Ground the shield to the controller side or on the input power side. Separate the wiring for communication devices from the drive input power lines. Install an EMC noise filter to the drive input power.
Digital Operator Display		Minor Fault Name
<i>CALL</i>	CALL	Serial Communication Transmission Error
Cause		Possible Solutions
		Communication has not yet been established.

Cause	Possible Solutions
Communications wiring is faulty, there is a short circuit, or something is not connected properly.	<ul style="list-style-type: none"> Check for wiring errors. Correct the wiring. Check for disconnected cables and short circuits. Repair as needed.
Programming error on the master side.	Check communications at start-up and correct programming errors.
Communications circuitry is damaged.	<ul style="list-style-type: none"> Perform a self-diagnostics check. If the problem continues, replace either the control board or the entire drive. For instructions on replacing the control board, contact Yaskawa or your nearest sales representative.
Termination resistor setting is incorrect.	Install a termination resistor at both ends of a communication line. Set the internal termination resistor switch correctly on slave drives. Place DIP switch S2 to the ON position.

Digital Operator Display		Minor Fault Name
CE	CE	MEMOBUS/Modbus Communication Error
		Control data was not received correctly for two seconds.
Cause	Possible Solutions	
A data error occurred due to noise.	<ul style="list-style-type: none"> Check options available to minimize the effects of noise. Take steps to counteract noise in the control circuit wiring, main circuit lines, and ground wiring. Reduce noise on the controller side. Use surge absorbers for the magnetic contactors or other components that may be causing the disturbance. Use only recommended shielded line. Ground the shield on the controller side or on the drive input power side. Separate all wiring for communication devices from drive input power lines. Install an EMC noise filter to the drive input power supply. 	
Communication protocol is incompatible.	<ul style="list-style-type: none"> Check the H5 parameter settings and the protocol setting in the controller. Ensure settings are compatible. 	
The CE detection time (H5-09) is set shorter than the time required for a communication cycle to take place.	<ul style="list-style-type: none"> Check the PLC. Change the software settings in the PLC. Set a longer CE detection time using parameter H5-09. 	
Incompatible PLC software settings or there is a hardware problem.	<ul style="list-style-type: none"> Check the PLC. Remove the cause of the error on the controller side. 	
Communications cable is disconnected or damaged.	<ul style="list-style-type: none"> Check the connector to make sure the cable has a signal. Replace the communications cable. 	

Digital Operator Display		Minor Fault Name
CrST	CrST	Cannot Reset
Cause	Possible Solutions	
Fault reset was being executed when a Run command was entered.	<ul style="list-style-type: none"> Ensure that a Run command cannot be entered from the external terminals or option during fault reset. Turn off the Run command. 	

Digital Operator Display		Minor Fault Name
dEv	dEv	Speed Deviation (when using a PG option card)
		The deviation between the speed reference and speed feedback is greater than the setting in F1-10 for longer than the time in F1-11.
Cause	Possible Solutions	
Load is too heavy	Reduce the load.	
Acceleration and deceleration times are set too short.	Increase the acceleration and deceleration times (C1-01 through C1-08).	
The load is locked up.	Check the machine.	
Parameter settings are inappropriate.	Check the settings of parameters F1-10 and F1-11.	
Incorrect speed feedback scaling when using terminal RP as speed feedback input in V/f Control.	<ul style="list-style-type: none"> Set H6-02 to value of the speed feedback signal frequency when the motor runs at the maximum speed. Adjust the speed feedback signal using parameters H6-03 through H6-05. Make sure the speed feedback signal frequency does not exceed the maximum input frequency of terminal RP. 	
The motor brake engaged.	Ensure the brake releases properly.	

6.5 Alarm Detection

Digital Operator Display		Minor Fault Name
$dn\bar{E}$	dnE	Drive Disabled
Cause		Possible Solutions
“Drive Enable” is set to a multi-function contact input (H1-□□ = 6A) and that signal was switched off.		Check the operation sequence.

Digital Operator Display		Minor Fault Name
$\bar{E}F$	EF	Forward/Reverse Run Command Input Error
Cause		Possible Solutions
Sequence error		Both forward run and reverse run closed simultaneously for longer than 0.5 s. Check the forward and reverse command sequence and correct the problem. Note: When minor fault EF detected, motor ramps to stop.

Digital Operator Display		Minor Fault Name
$\bar{E}F0$	EF0	Option Card External Fault
Cause		Possible Solutions
An external fault was received from the PLC with F6-03 set to 3, which allows the drive to continue running after an external fault occurs.		An external fault condition is present. • Remove the cause of the external fault. • Remove the external fault input from the PLC.
There is a problem with the PLC program.		Check the PLC program and correct problems.

Digital Operator Display		Minor Fault Name
$\bar{E}F1$	EF1	External Fault (Input Terminal S1)
Cause		Possible Solutions
An external device has tripped an alarm function.		Remove the cause of the external fault and reset the multi-function input value.
Wiring is incorrect.		• Ensure the signal lines have been connected properly to the terminals assigned for external fault detection (H1-□□ = 2C to 2F). • Reconnect the signal line.
Multi-function contact inputs are set incorrectly.		• Check if the unused terminals have been set for H1-□□ = 2C to 2F (External Fault). • Change the terminal settings.
$\bar{E}F2$	EF2	External fault (input terminal S2)
Cause		Possible Solutions
Wiring is incorrect.		• Ensure the signal lines have been connected properly to the terminals assigned for external fault detection (H1-□□ = 2C to 2F). • Reconnect the signal line.
Multi-function contact inputs are set incorrectly.		• Check if the unused terminals have been set for H1-□□ = 2C to 2F (External Fault). • Change the terminal settings.
$\bar{E}F3$	EF3	External fault (input terminal S3)
Cause		Possible Solutions
Wiring is incorrect.		• Ensure the signal lines have been connected properly to the terminals assigned for external fault detection (H1-□□ = 2C to 2F). • Reconnect the signal line.
Multi-function contact inputs are set incorrectly.		• Check if the unused terminals have been set for H1-□□ = 2C to 2F (External Fault). • Change the terminal settings.
$\bar{E}F4$	EF4	External fault (input terminal S4)
Cause		Possible Solutions
Wiring is incorrect.		• Ensure the signal lines have been connected properly to the terminals assigned for external fault detection (H1-□□ = 2C to 2F). • Reconnect the signal line.
Multi-function contact inputs are set incorrectly.		• Check if the unused terminals have been set for H1-□□ = 2C to 2F (External Fault). • Change the terminal settings.
$\bar{E}F5$	EF5	External fault (input terminal S5)
Cause		Possible Solutions
Wiring is incorrect.		• Ensure the signal lines have been connected properly to the terminals assigned for external fault detection (H1-□□ = 2C to 2F). • Reconnect the signal line.
Multi-function contact inputs are set incorrectly.		• Check if the unused terminals have been set for H1-□□ = 2C to 2F (External Fault). • Change the terminal settings.
$\bar{E}F6$	EF6	External fault (input terminal S6)
Cause		Possible Solutions
Wiring is incorrect.		• Ensure the signal lines have been connected properly to the terminals assigned for external fault detection (H1-□□ = 2C to 2F). • Reconnect the signal line.
Multi-function contact inputs are set incorrectly.		• Check if the unused terminals have been set for H1-□□ = 2C to 2F (External Fault). • Change the terminal settings.
$\bar{E}F7$	EF7	External fault (input terminal S7)
Cause		Possible Solutions
Wiring is incorrect.		• Ensure the signal lines have been connected properly to the terminals assigned for external fault detection (H1-□□ = 2C to 2F). • Reconnect the signal line.
Multi-function contact inputs are set incorrectly.		• Check if the unused terminals have been set for H1-□□ = 2C to 2F (External Fault). • Change the terminal settings.
$\bar{E}F8$	EF8	External fault (input terminal S8)
Cause		Possible Solutions
Wiring is incorrect.		• Ensure the signal lines have been connected properly to the terminals assigned for external fault detection (H1-□□ = 2C to 2F). • Reconnect the signal line.
Multi-function contact inputs are set incorrectly.		• Check if the unused terminals have been set for H1-□□ = 2C to 2F (External Fault). • Change the terminal settings.

Digital Operator Display		Minor Fault Name
FbH	FbH	Excessive PID Feedback
Cause		Possible Solutions
The PID feedback input is higher than the level set to b5-36 for longer than the time set to b5-37, and b5-12 is set to 1 or 4.		

Parameter settings for b5-36 and b5-37 are incorrect.	Check parameters b5-36 and b5-37.
PID feedback wiring is faulty.	Correct the wiring.
Feedback sensor has malfunctioned.	Check the sensor and replace it if damaged.
Feedback input circuit is damaged.	Replace either the control board or the entire drive. For instructions on replacing the control board, contact Yaskawa or your nearest sales representative.

Digital Operator Display		Minor Fault Name
<i>FbL</i>	FbL	PID Feedback Loss
		The PID feedback input is lower than the level set to b5-13 for longer than the time set to b5-14.
Cause		Possible Solutions
Parameter settings for b5-13 and b5-14 are incorrect.		Check parameters b5-13 and b5-14.
PID feedback wiring is faulty.		Correct the wiring.
Feedback sensor has malfunctioned.		Check the sensor and replace it if damaged.
Feedback input circuit is damaged.		Replace either the control board or the entire drive. For instructions on replacing the control board, contact Yaskawa or your nearest sales representative.

Digital Operator Display		Minor Fault Name
<i>Hbb</i>	Hbb	Safe Disable Signal Input <I>
		Both Safe Disable Input channels are open.
Cause		Possible Solutions
Both Safe Disable Inputs H1 and H2 are open.		<ul style="list-style-type: none"> Check signal status at the input terminals H1 and H2. Check the Sink/Source Selection for the digital inputs. If the Safe Disable function is not utilized, determine if terminals H1-HC, and H2-HC are linked.
Internally, both Safe Disable channels are broken.		Replace either the control board or the entire drive. For instructions on replacing the control board, contact Yaskawa or your nearest sales representative.

<I> Terminals H1, H2, DM+, and DM- on 600 V class models are designed to the functionality, but are not certified to EN61800-5-1, ISO13849 Cat. 3, IEC/EN61508 SIL2, Insulation coordination: class 1.

Digital Operator Display		Minor Fault Name
<i>HbbF</i>	HbbF	Safe Disable Signal Input <I>
		One Safe Disable channel is open while the other channel is closed.
Cause		Possible Solutions
The signals to the Safe Disable inputs are wrong or the wiring is incorrect.		Check signal status at the input terminals H1 and H2. If the Safe Disable function is not utilized, terminals H1-HC, and H2-HC must be linked.
One of the Safe Disable channels is faulty.		Replace either the control board or the entire drive. For instructions on replacing the control board, contact Yaskawa or your nearest sales representative.

<I> Terminals H1, H2, DM+, and DM- on 600 V class models are designed to the functionality, but are not certified to EN61800-5-1, ISO13849 Cat. 3, IEC/EN61508 SIL2, Insulation coordination: class 1.

Digital Operator Display		Minor Fault Name
<i>HcR</i>	HCA	Current Alarm
		Drive current exceeded overcurrent warning level (150% of the rated current).
Cause		Possible Solutions
Load is too heavy.		Reduce the load for applications with repetitive operations (i.e., stops and starts), or replace the drive.
Acceleration and deceleration times are too short.		<ul style="list-style-type: none"> Calculate the torque required during acceleration and for the inertia moment. If the torque level is not right for the load, take the following steps: <ul style="list-style-type: none"> Increase the acceleration and deceleration times (C1-01 through C1-08). Increase the capacity of the drive.
A special-purpose motor is being used, or the drive is attempting to run a motor greater than the maximum allowable capacity.		<ul style="list-style-type: none"> Check the motor capacity. Use a motor appropriate for the drive. Ensure the motor is within the allowable capacity range.
The current level increased due to Speed Search after a momentary power loss or while attempting to perform a fault restart.		The alarm will only appear briefly. There is no need to take action to prevent the alarm from occurring in such instances.

6.5 Alarm Detection

Digital Operator Display		Minor Fault Name
LF-1	LT-1	Cooling Fan Maintenance Time
		The cooling fan has reached its expected maintenance period and may need to be replaced. Note: An alarm output (H2-□□ = 10) will only be triggered if both (H2-□□ = 2F and H2-□□ = 10) are set.
Cause		Possible Solutions
The cooling fan has reached 90% of its expected performance life.		Replace the cooling fan and set o4-03 to 0 to reset the Maintenance Monitor.

Digital Operator Display		Minor Fault Name
LF-2	LT-2	Capacitor Maintenance Time
		The main circuit and control circuit capacitors are nearing the end of their expected performance life. Note: An alarm output (H2-□□ = 10) will only be triggered if H2-□□ = 2F.
Cause		Possible Solutions
The main circuit and control circuit capacitors have reached 90% of their expected performance lives.		Replace either the control board or the entire drive. For instructions on replacing the control board, contact Yaskawa or your nearest sales representative.

Digital Operator Display		Minor Fault Name
LF-3	LT-3	Soft Charge Bypass Relay Maintenance Time
		The DC bus soft charge relay is nearing the end of its expected performance life. Note: An alarm output (H2-□□ = 10) will only be triggered if H2-□□ = 2F.
Cause		Possible Solutions
The DC bus soft charge relay has reached 90% of expected performance life.		Replace either the control board or the entire drive. For instructions on replacing the control board, contact Yaskawa or your nearest sales representative.

Digital Operator Display		Minor Fault Name
LF-4	LT-4	IGBT Maintenance Time (50%)
		IGBTs have reached 50% of their expected performance life. Note: An alarm output (H2-□□ = 10) will only be triggered if H2-□□ = 2F.
Cause		Possible Solutions
IGBTs have reached 50% of their expected performance life.		Check the load, carrier frequency, and output frequency.

Digital Operator Display		Minor Fault Name
oH	oH	Heatsink Overheat
		The temperature of the heatsink exceeded the overheat pre-alarm level set to L8-02 (90-100 °C). Default value for L8-02 is determined by drive capacity (o2-04).
Cause		Possible Solutions
Surrounding temperature is too high		<ul style="list-style-type: none"> Check the surrounding temperature. Improve the air circulation within the enclosure panel. Install a fan or air conditioner to cool surrounding area. Remove anything near drive that may cause extra heat.
Internal cooling fan has stopped.		<ul style="list-style-type: none"> Replace the cooling fan. <i>Refer to Cooling Fan Replacement: 2A0018 to 2A0081, 4A0007 to 4A0044, and 5A0006 to 5A0032 on page 409.</i> After replacing the drive, set parameter o4-03 to 0 to reset the cooling fan operation time.
Airflow around the drive is restricted.		<ul style="list-style-type: none"> Provide proper installation space around the drive as indicated in the manual. <i>Refer to Installation Orientation and Spacing on page 54</i> for details. Allow for the proper space and ensure that there is sufficient circulation around the control panel. Check for dust or other foreign materials clogging the cooling fan. Clear debris caught in the fan that restricts air circulation.

Digital Operator Display		Minor Fault Name
oH2	oH2	Drive Overheat Warning
		“Drive Overheat Warning” was input to a multi-function input terminal, S1 through S8 (H1-□□ = B).
Cause		Possible Solutions

An external device triggered an overheat warning in the drive.	Search for the device that tripped the overheat warning. Remove the cause of the problem.
--	---

Digital Operator Display		Minor Fault Name
oH3	oH3	Motor Overheat The motor overheat signal entered to a multi-function analog input terminal exceeded the alarm level (H3-02, H3-06 or H3-10 = E).
Cause		Possible Solutions
Motor thermostat wiring is faulty (PTC input).		Repair the PTC input wiring.
There is a fault on the machine side (e.g., the machine is locked up).		<ul style="list-style-type: none"> • Check the status of the machine. • Remove the cause of the fault.
Motor has overheated.		<ul style="list-style-type: none"> • Check the load size, accel/decel times, and cycle times. • Decrease the load. • Increase accel and decel times (C1-01 to C1-08). • Adjust the preset V/f pattern (E1-04 through E1-10). This involves reducing E1-08 and E1-10. Note: Refrain from lowering E1-08 and E1-10 excessively to prevent a reduction in load tolerance at low speeds. • Check the motor-rated current. • Enter motor-rated current on motor nameplate (E2-01). • Ensure the motor cooling system is operating normally. • Repair or replace the motor cooling system.

Digital Operator Display		Minor Fault Name
oH5 <1>	oH5	Motor Overheat (NTC Input) The motor temperature exceeded the level set to L1-16 (or L1-18 for motor 2)
Cause		Possible Solutions
Motor has overheated.		<ul style="list-style-type: none"> • Reduce the load. • Check the ambient temperature.

<1> Detected in models 4A0930 and 4A1200.

Digital Operator Display		Minor Fault Name
oL3	oL3	Overtorque 1 Drive output current (or torque in OLV, CLV, AOLV/PM, and CLV/PM) was greater than L6-02 for longer than the time set to L6-03.
Cause		Possible Solutions
Inappropriate parameter settings.		Check parameters L6-02 and L6-03.
There is a fault on the machine side (e.g., the machine is locked up).		<ul style="list-style-type: none"> • Check the status of the machine. • Remove the cause of the fault.

Digital Operator Display		Minor Fault Name
oL4	oL4	Overtorque 2 Drive output current (or torque in OLV, CLV, AOLV/PM, CLV/PM) was greater than L6-05 for longer than the time set to L6-06.
Cause		Possible Solutions
Parameter settings are not appropriate.		Check parameters L6-05 and L6-06.
There is a fault on the machine side (e.g., the machine is locked up).		<ul style="list-style-type: none"> • Check the status of the machine being used. • Remove the cause of the fault.

Digital Operator Display		Minor Fault Name
oL5	oL5	Mechanical Weakening Detection 1 Overtorque occurred, matching the conditions specified in L6-08.
Cause		Possible Solutions
Overtorque occurred, triggering the mechanical weakening level set to L6-08.		Check for the cause of mechanical weakening.

6.5 Alarm Detection

Digital Operator Display		Minor Fault Name
<i>o5</i>	oS	Overspeed
		The motor speed feedback exceeded the F1-08 setting.
Cause		Possible Solutions
Overshoot is occurring.		<ul style="list-style-type: none"> • Increase the settings for C5-01 (Speed Control Proportional Gain 1) and reduce C5-02 (Speed Control Integral Time 1). • If using a Closed Loop Vector mode enable Feed Forward Control and perform Inertia Auto-Tuning.
Incorrect speed feedback scaling if terminal RP is used as speed feedback input in V/f control		<ul style="list-style-type: none"> • Set H6-02 to value of the speed feedback signal frequency when the motor runs at the maximum speed. • Adjust the input signal using parameters H6-03 through H6-05.
Incorrect PG pulse number has been set		Check and correct parameter F1-01.
Inappropriate parameter settings.		Check the setting for the overspeed detection level and the overspeed detection time (F1-08 and F1-09).

Digital Operator Display		Minor Fault Name
<i>ou</i>	ov	DC Bus Overvoltage
		The DC bus voltage exceeded the trip point.
		<ul style="list-style-type: none"> • For 200 V class drives: approximately 410 V • For 400 V class drives: approximately 820 V (740 V when E1-01 is less than 400) • For 600 V class drives: approximately 1040 V
Cause		Possible Solutions
Surge voltage present in the drive input power.		<ul style="list-style-type: none"> • Install a DC link choke or an AC reactor. • Voltage surge can result from a thyristor convertor and a phase advancing capacitor operating on the same drive input power system.
The motor is short-circuited.		<ul style="list-style-type: none"> • Check the motor power cable, relay terminals and motor terminal box for short circuits. • Correct grounding shorts and turn the power back on.
Ground current has overcharged the main circuit capacitors via the drive input power.		
Noise interference causes the drive to operate incorrectly.		<ul style="list-style-type: none"> • Review possible solutions for handling noise interference. • Review section on handling noise interference and check control circuit lines, main circuit lines and ground wiring. • If the magnetic contactor is identified as a source of noise, install a surge protector to the MC coil.
		Set number of fault restarts (L5-01) to a value other than 0.
PG cable is disconnected.		Reconnect the cable.
PG cable wiring is wrong.		Correct the wiring.
Noise interference along PG encoder wiring.		Separate PG wiring from the source of the noise (often output wiring from the drive).

Digital Operator Display		Minor Fault Name
<i>PASS</i>	PASS	MEMOBUS/Modbus Comm. Test Mode Complete
Cause		Possible Solutions
MEMOBUS/Modbus test has finished normally.		This verifies that the test was successful.

Digital Operator Display		Minor Fault Name
<i>PGo</i>	PGo	PG Disconnect (for Control Mode with PG)
		Detected when no PG pulses are received for a time longer than setting in F1-14.
Cause		Possible Solutions
PG cable is disconnected.		Reconnect the cable.
PG cable wiring is wrong.		Correct the wiring.
PG encoder does not have enough power.		Make sure the correct power supply is properly connected to the PG encoder.
Brake is holding the PG.		Ensure the brake releases properly

Digital Operator Display		Minor Fault Name
<i>PGoH</i>	PGoH	PG Hardware Fault (detected when using a PG-X3 option card)
		PG cable has become disconnected.
Cause		Possible Solutions
PG cable is disconnected.		Reconnect the cable and check the setting of F1-20.

Digital Operator Display		Minor Fault Name
rUn	rUn	Motor Switch during Run
Cause		Possible Solutions
A motor switch command was entered during run.		Change the operation pattern so that the motor switch command is entered while the drive is stopped.

Digital Operator Display		Minor Fault Name
SE	SE	MEMOBUS/Modbus Communication Test Mode Error
Cause		Possible Solutions
A digital input set to 67H (MEMOBUS/Modbus test) was closed while the drive was running.		Stop the drive and run the test again.

Digital Operator Display		Minor Fault Name
THo	THo	Thermistor Disconnect
Cause		Possible Solutions
The motor thermistor is not connected properly.		Check the thermistor wiring.

<1> Detected in models 4A0930 and 4A1200.

Digital Operator Display		Minor Fault Name
$TrPC$	TrPC	IGBT Maintenance Time (90%)
Cause		Possible Solutions
IGBTs have reached 90% of their expected performance life.		Replace the drive.

Digital Operator Display		Minor Fault Name
$UL3$	UL3	Undertorque Detection 1
Cause		Possible Solutions
Inappropriate parameter settings.		Check parameters L6-02 and L6-03.
Load has dropped or decreased significantly.		Check for broken parts in the transmission system.

Digital Operator Display		Minor Fault Name
$UL4$	UL4	Undertorque Detection 2
Cause		Possible Solutions
Inappropriate parameter settings.		Check parameters L6-05 and L6-06.
The load has dropped or decreased significantly.		Check for broken parts in the transmission system.

Digital Operator Display		Minor Fault Name
Uv	Uv	Undervoltage
Cause		Possible Solutions
Phase loss in the drive input power.		Check for wiring errors in the main circuit drive input power. Correct the wiring.

6.5 Alarm Detection

Loose wiring in the drive input power terminals.	<ul style="list-style-type: none"> • Ensure the terminals have been properly tightened. • Apply the tightening torque to the terminals as specified. <i>Refer to Wire Gauges and Tightening Torque on page 89.</i>
There is a problem with the drive input power voltage.	<ul style="list-style-type: none"> • Check the voltage. • Lower the voltage of the drive input power so that it is within the limits listed in the specifications.
Drive internal circuitry is worn.	<ul style="list-style-type: none"> • Check the maintenance time for the capacitors (U4-05). • Replace either the control board or the entire drive if U4-05 exceeds 90%. For instructions on replacing the control board, contact Yaskawa or your nearest sales representative.
The drive input power transformer is too small and voltage drops when the power is switched on.	<ul style="list-style-type: none"> • Check for an alarm when the magnetic contactor, line breaker, and leakage breaker are closed. • Check the capacity of the drive input power transformer.
Air inside the drive is too hot.	Check the temperature inside the drive.
The CHARGE light is broken or disconnected.	Replace either the control board or the entire drive. For instructions on replacing the control board, contact Yaskawa or your nearest sales representative.

Digital Operator Display		Minor Fault Name
$u\alpha F$	voF	Output Voltage Detection Fault
		There is a problem with the output voltage.
Cause		Possible Solutions
Hardware is damaged.		Replace either the control board or the entire drive. For instructions on replacing the control board, contact Yaskawa or your nearest sales representative.

6.6 Operator Programming Errors

◆ Operator Programming Error Codes, Causes, and Possible Solutions

An Operator Programming Error (oPE) occurs when a contradictory parameter is set or an individual parameter is set to an inappropriate value.

The drive will not operate until the parameter or parameters causing the problem are set correctly. An oPE, however, does not trigger an alarm or fault output. If an oPE occurs, investigate the cause and refer to [Table 6.16](#) for the appropriate action. When an oPE appears on the operator display, press the ENTER button to view U1-18 and see which parameter is causing the oPE.

Table 6.16 oPE Codes, Causes, and Possible Solutions

Digital Operator Display		Error Name
oPE01	oPE01	Drive Capacity Setting Fault
		Drive capacity and the value set to o2-04 do not match.
Cause		Possible Solutions
The drive model selection (o2-04) and the actual capacity of the drive are not the same.		Correct the value set to o2-04.

Digital Operator Display		Error Name
oPE02	oPE02	Parameter Range Setting Error
		Use U1-18 to find parameters set outside the range.
Cause		Possible Solutions
Parameters were set outside the possible setting range.		Set parameters to the proper values.
Note: When multiple errors occur simultaneously, other errors are given precedence over oPE02.		

Digital Operator Display		Error Name
oPE03	oPE03	Multi-Function Input Selection Error
		A contradictory setting is assigned to multi-function contact inputs H1-01 to H1-08.
Cause		Possible Solutions
<ul style="list-style-type: none"> The same function is assigned to two multi-function inputs. Excludes “Not used” and “External Fault.” 		<ul style="list-style-type: none"> Ensure all multi-function inputs are assigned to different functions. Re-enter the multi-function settings to ensure this does not occur.
The Up command was set but the Down command was not, or vice versa (settings 10 vs. 11).		Properly set the functions that required for use in combination with other functions.
The Up 2 command was set but the Down 2 command was not, or vice versa (settings 75 vs. 76).		
<ul style="list-style-type: none"> Run/Stop command for a 2-wire sequence was set (H1-□□ = 42), but Forward/Reverse command (H1-□□ = 43) was not. “Drive Enable” is set to multi-function input S1 or S2 (H1-01 = 6A or H1-02 = 6A). 		Properly set the functions that required for use in combination with other functions.
Two of the following functions are set simultaneously: <ul style="list-style-type: none"> Up/Down Command (10 vs. 11) Up 2/Down 2 Command (75 vs. 76) Hold Accel/Decel Stop (A) Analog Frequency Reference Sample/Hold (1E) Offset Frequency 1, 2, 3 Calculations (44, 45, 46) 		<ul style="list-style-type: none"> Check if contradictory settings have simultaneously been assigned to the multi-function input terminals. Correct setting errors.
The Up/Down command (10, 11) and PID control (b5-01) are enabled simultaneously.		Set b5-01 to 0 to disable control PID or disable the Up/Down command.

6.6 Operator Programming Errors

<p>Settings for N.C. and N.O. input for the following functions were selected simultaneously:</p> <ul style="list-style-type: none"> External Search Command 1 and External Search Command 2 (61 vs. 62) Fast Stop N.O. and Fast Stop N.C. (15 vs. 17) KEB for Momentary Power Loss and High Slip Braking (65, 66, 7A, 7B vs. 68) Motor Switch Command and Accel/Decel Time 2 (16 vs. 1A) KEB Command 1 and KEB Command 2 (65, 66 vs. 7A, 7B) FWD Run Command (or REV) and FWD/REV Run Command (2-wire) (40, 41 vs. 42, 43) External DB Command and Drive Enable (60 vs. 6A) Motor Switch Command and Up 2/Down 2 Command (16 vs. 75, 76) 	<ul style="list-style-type: none"> Check if contradictory settings have simultaneously been assigned to the multi-function input terminals. Correct setting errors.
<p>One of the following settings was entered while H1-□□ = 2 (External Reference 1/2):</p> <ul style="list-style-type: none"> b1-15 = 4 (Pulse Train Input) but the pulse train input selection is not set for the frequency reference (H6-01 > 0) b1-15 or b1-16 set to 3 but no option card is connected Although b1-15 = 1 (Analog Input) and H3-02 or H3-10 are set to 0 (Frequency Bias) 	Correct the settings for the multi-function input terminal parameters.
H2-□□ is set to 38 (Drive Enabled) and H1-□□ is not set to 6A (Drive Enable).	
H1-□□ is set to 7E (Direction Detection) and H6-01 is not set to 3 (for V/f Control with PG using terminal RP as speed feedback input).	
H1-□□ is set to 16 when using PG-RT3.	Correct the setting. PG-RT3 is not available for the application with Motor 2 selection.

Digital Operator Display		Error Name
oPE04	oPE04	Initialization Required
Cause		Possible Solutions
The drive, control board, or terminal board have been replaced and the parameter settings between the control board and the terminal board no longer match.		Set A1-03 to 5550 to load the parameter settings stored in the terminal board to the drive. Initialize parameters after drive replacement by setting A1-03 to 1110 or 2220.

Digital Operator Display		Error Name
oPE05	oPE05	Run Command/Frequency Reference Source Selection Error
Cause		Possible Solutions
Frequency reference is assigned to an option card (b1-01 = 3) and an input option card is not connected to the drive.	Reconnect the input option card to the drive.	
The Run command is assigned to an option card (b1-02 = 3) and an input option card is not connected to the drive.		
Frequency reference is assigned to the pulse train input (b1-01 = 4) and terminal RP is not set for frequency reference input (H6-01 > 0)	Set H6-01 to 0.	
Although the digital card input is set for BCD special for a 5-digit input (F3-01 = 6), the data length is set for 8-bit or 12-bit (F3-03 = 0, 1).	Set F3-03 to 2 to set the input data for 16-bit.	
<p>The following values have been set while an AI-A3 option card is installed:</p> <ul style="list-style-type: none"> The source of frequency reference setting is assigned to an option card (b1-01 = 3). The action for the analog card is set for separate terminal input (F2-01 = 0). 	Properly set parameters.	

Digital Operator Display		Error Name
oPE06	oPE06	Control Method Selection Error
Cause		Possible Solutions
A control mode has been selected that requires a PG option card to be installed, but no PG encoder is installed (A1-02 = 1, 3, or 7).		<ul style="list-style-type: none"> Connect a PG option card. Correct the value set to A1-02.

Digital Operator Display		Error Name
<i>oPE07</i>	oPE07	Multi-Function Analog Input Selection Error A contradictory setting is assigned to multi-function analog inputs H3-02, H3-10, or H3-06 and PID functions conflict.
Cause		Possible Solutions
At least two analog input terminals are set to the same function (i.e., at least two of these parameters have the same setting: H3-02, H3-10, or H3-06).		Change the settings to H3-02, H3-10, and H3-06 so that functions no longer conflict. Note: Both 0 (Frequency Reference Bias) and F (Not Used) can be set to H3-02, H3-10, or H3-06 simultaneously.
The following simultaneous contradictory settings: <ul style="list-style-type: none"> H3-02, H3-10, or H3-06 = B (PID Feedback) while H6-01 (Pulse Train Input) = 1 (PID Feedback) H3-02, H3-10, or H3-06 = C (PID Target Value) while H6-01 = 2 (pulse train input sets the PID target value) H3-02, H3-10, or H3-06 = C (PID Target Value) while b5-18 = 1 (enables b5-19 as the target PID value) H6-01 = 2 (PID target) while b5-18 = 1 (enables b5-19 as the target PID value) 		Disable one of the PID selections.

Digital Operator Display		Error Name
<i>oPE08</i>	oPE08	Parameter Selection Error A function has been set that cannot be used in the motor control method selected.
Cause		Possible Solutions
Attempted to use a function that is not valid for the selected control mode.		Check the motor control method and the functions available.
In OLV, n2-02 is longer than n2-03		Adjust parameter values so n2-02 is shorter than n2-03.
In OLV, C4-02 is longer than C4-06		Adjust parameter values so C4-02 is shorter than C4-06.
In OLV/PM, parameters E5-02 to E5-07 are set to 0.		<ul style="list-style-type: none"> Set the correct motor code in accordance with the motor being used (E5-01). When using a special-purpose motor, set E5-□□ in accordance with the test report provided.
The following settings have occurred in OLV/PM: <ul style="list-style-type: none"> E5-03 does not equal 0 E5-09 and E5-24 are both equal to 0, or neither equals 0 		<ul style="list-style-type: none"> Set E5-09 or E5-24 to the correct value, and set the other to 0. Set the motor rated current for PM to 0 (E5-03).
b1-14 (Phase Order Selection) is set to 1 (Switch phase order) when using a PG option card.		Correct the parameter settings.
In AOLV/PM High Frequency Injection is disabled (n8-57 = 0) and the minimum frequency (E1-09) is set lower than 1/20 of the base frequency setting.		Correct the parameter settings.
Note: Use U1-18 to find parameters that are set outside the specified setting range. When multiple errors occur simultaneously, other errors are given precedence over oPE08.		

Digital Operator Display		Error Name
<i>oPE09</i>	oPE09	PID Control Selection Fault PID control function selection is incorrect. Requires that PID control is enabled (b5-01 = 1 to 4).
Cause		Possible Solutions
The following simultaneous contradictory settings have occurred: <ul style="list-style-type: none"> b5-15 is not set to 0.0 (PID Sleep Function Operation Level) The stopping method is set to either DC Injection Braking or coast to stop with a timer (b1-03 = 2 or 3). 		<ul style="list-style-type: none"> Set b5-15 to a value other than 0.0. Set the stopping method to coast to stop or ramp to stop (b1-03 = 0 or 1).
b5-01 is set to 1 or 2, enabling PID control, but the lower limit for the frequency reference (d2-02) is not set to 0 while reverse output is enabled (b5-11 = 1).		Correct the parameter settings.
b5-01 is set to 3 or 4, enabling PID control, but the lower limit for the frequency reference (d2-01) is not 0.		Correct the parameter settings.

6.6 Operator Programming Errors

Digital Operator Display		Error Name
<i>oPE 10</i>	oPE10	V/f Data Setting Error One of the following setting errors has occurred: <ul style="list-style-type: none"> E1-09 ≤ E1-07 < E1-06 ≤ E1-11 ≤ E1-04 E3-09 ≤ E3-07 < E3-06 ≤ E3-11 ≤ E3-04
Cause		Possible Solutions
V/f pattern setting error.		Correct the settings for E1-04, E1-06, E1-07, E1-09, and E1-11. For motor 2, correct E3-04, E3-06, E3-07, E3-09, and E3-11.

Digital Operator Display		Error Name
<i>oPE 11</i>	oPE11	Carrier Frequency Setting Error Correct the setting for the carrier frequency.
Cause		Possible Solutions
The following simultaneous contradictory settings have occurred: C6-05 > 6 and C6-04 > C6-03 (carrier frequency lower limit is greater than the upper limit). If C6-05 ≤ 6, the drive operates at C6-03. The upper and lower limits between C6-02 and C6-05 are contradictory.		Correct the parameter settings.

Digital Operator Display		Error Name
<i>oPE 13</i>	oPE13	Pulse Monitor Selection Error Incorrect setting of monitor selection for pulse train (H6-06).
Cause		Possible Solutions
Scaling for the pulse train monitor is set to 0 (H6-07 = 0) while H6-06 is not set to 101, 102, 105, or 116.		Change scaling for the pulse train monitor or set H6-06 to 101, 102, 105, or 116.

Digital Operator Display		Error Name
<i>oPE 15</i>	oPE15	Torque Control Setting Error Parameter settings that are not allowed in combination with Torque Control have been set.
Cause		Possible Solutions
Torque Control is enabled (d5-01 = 1) while the Speed/Torque Control switch function is assigned to a digital input (H1-□□ = 71). Either d5-01 is set to 1 to enable Torque Control, or the Speed/Torque Control switch is assigned to a digital input H1-□□ = 71, while at the same time: <ul style="list-style-type: none"> Feed Forward is enabled (n5-01 = 1), or Droop Control is enabled (b7-01 ≠ 0), or Intelligent Stall Prevention or Intelligent Stall Prevention 2 is enabled (L3-04 = 2 or 5), or A digital input is set for the power KEB 1 or KEB 2 (H1-□□ = 7A or 7B) 		Correct the parameter settings.

Digital Operator Display		Error Name
<i>oPE 16</i>	oPE16	Energy Savings Constants Error
Cause		Possible Solutions
In AOLV/PM, the automatically calculated energy saving coefficients are out of the allowable range.		Check and correct the motor data in E5 parameters.

Digital Operator Display		Error Name
<i>oPE 18</i>	oPE18	Online Tuning Parameter Setting Error Parameters controlling online tuning are not set correctly.
Cause		Possible Solutions
One of the following errors occurred while online tuning was enabled in OLV (A1-02 = 2): <ul style="list-style-type: none"> E2-02 was set below 30% of the original default value E2-06 was set below 50% of the original default value E2-03 = 0 		Set E2-02, E2-03, and E2-06 to the correct values.

6.7 Auto-Tuning Fault Detection

When the Auto-Tuning faults shown below are detected, the fault is displayed on the operator and the motor coasts to a stop. Auto-Tuning faults do not trigger a multi-function terminal set for fault or alarm output.

An End□ error indicates that although Auto-Tuning has successfully completed, there is some discrepancy in the calculations. If an End□ error occurs, check for the cause of the error using the table in this section, and perform Auto-Tuning again or manually set the motor parameters after fixing the problem. Start the application if no problem can be diagnosed despite the existence of the End□ error.

◆ Auto-Tuning Codes, Causes, and Possible Solutions

Table 6.17 Auto-Tuning Codes, Causes, and Possible Solutions

Digital Operator Display		Error Name
<i>End1</i>	End1	Excessive V/f Setting (detected only during Rotational Auto-Tuning and displayed after Auto-Tuning is complete)
Cause		Possible Solutions
The torque reference exceeded 20% during Auto-Tuning.		<ul style="list-style-type: none"> Prior to Auto-Tuning, verify the information on the motor nameplate. Enter proper values from motor nameplate to parameters T1-03 to T1-05 and repeat Auto-Tuning.
The results from Auto-Tuning the no-load current exceeded 80%.		<ul style="list-style-type: none"> If possible, disconnect the motor from the load and perform Auto-Tuning. If the load cannot be uncoupled, use the current Auto-Tuning results.

Digital Operator Display		Error Name
<i>End2</i>	End2	Motor Iron-Core Saturation Coefficient (detected only during Rotational Auto-Tuning and displayed after Auto-Tuning is complete)
Cause		Possible Solutions
Motor data entered during Auto-Tuning was incorrect.		<ul style="list-style-type: none"> Make sure the data entered to the T1 parameters match the information written on the motor nameplate. Restart Auto-Tuning and enter the correct information.
Results from Auto-Tuning are outside the parameter setting range, assigning the iron-core saturation coefficients (E2-07 and E2-08) to temporary values.		<ul style="list-style-type: none"> Check and correct faulty motor wiring. Disconnect the motor from machine and perform Rotational Auto-Tuning.

Digital Operator Display		Error Name
<i>End3</i>	End3	Rated Current Setting Alarm (displayed after Auto-Tuning is complete)
Cause		Possible Solutions
The correct current rating printed on the motor nameplate was not entered into T1-04.		<ul style="list-style-type: none"> Check the setting of parameter T1-04. Check the motor data and repeat Auto-Tuning.

Digital Operator Display		Error Name
<i>End4</i>	End4	Adjusted Slip Calculation Error
Cause		Possible Solutions
The calculated slip is outside the allowable range.		<ul style="list-style-type: none"> Make sure the data entered for Auto-Tuning is correct. If possible, perform Rotational Auto-Tuning. If not possible, perform Stationary Auto-Tuning 2.

Digital Operator Display		Error Name
<i>End5</i>	End5	Resistance Tuning Error
Cause		Possible Solutions
The calculated resistance value is outside the allowable range.		<ul style="list-style-type: none"> Double-check the data entered for the Auto-Tuning process. Check the motor and motor cable connection for faults.

Digital Operator Display		Error Name
<i>End6</i>	End6	Leakage Inductance Alarm
Cause		Possible Solutions
The calculated leakage inductance value is outside the allowable range.		Double-check the data entered for the Auto-Tuning process.

6.7 Auto-Tuning Fault Detection

Digital Operator Display		Error Name
End7	End7	No-Load Current Alarm
Cause		Possible Solutions
The entered no-load current value was outside the allowable range.		Check and correct faulty motor wiring.
Auto-Tuning results were less than 5% of the motor rated current.		Double-check the data entered for the Auto-Tuning process.

Digital Operator Display		Error Name
Er-01	Er-01	Motor Data Error
Cause		Possible Solutions
Motor data or data entered during Auto-Tuning was incorrect		<ul style="list-style-type: none"> Check that the motor data entered to T1 parameters matches motor nameplate input before Auto-Tuning. Restart Auto-Tuning and enter the correct information.
Motor output power and motor-rated current settings (T1-02 and T1-04) do not match.		<ul style="list-style-type: none"> Check the drive and motor capacities. Correct the settings of parameters T1-02 and T1-04.
Motor rated current and detected no-load current are inconsistent.		<ul style="list-style-type: none"> Check the motor rated current and no-load current. Correct the settings of parameters T1-04 and E2-03.
Base frequency and motor rated speed (T1-05 and T1-07) do not match.		<ul style="list-style-type: none"> Correct the settings of parameters T1-05 and T1-07. Check that the correct number of poles were entered to T1-06.

Digital Operator Display		Error Name
Er-02	Er-02	Minor Fault
Cause		Possible Solutions
An alarm was triggered during Auto-Tuning.		Exit the Auto-Tuning menu, check the alarm code, remove the alarm cause, and repeat Auto-Tuning.

Digital Operator Display		Error Name
Er-03	Er-03	STOP Button Input
Cause		Possible Solutions
Auto-Tuning canceled by pressing STOP button.		Auto-Tuning did not complete properly. Restart Auto-Tuning.

Digital Operator Display		Error Name
Er-04	Er-04	Line-to-Line Resistance Error
Cause		Possible Solutions
Motor data entered during Auto-Tuning was incorrect.		<ul style="list-style-type: none"> Make sure the data entered to the T1 parameters match the information written on the motor nameplate. Restart Auto-Tuning and enter the correct information.
Results from Auto-Tuning are outside the parameter setting range or the tuning process took too long.		Check and correct faulty motor wiring.
Faulty motor cable or cable connection.		

Digital Operator Display		Error Name
Er-05	Er-05	No-Load Current Error
Cause		Possible Solutions
Motor data entered during Auto-Tuning was incorrect.		<ul style="list-style-type: none"> Make sure the data entered to the T1 parameters match the information written on the motor nameplate. Restart Auto-Tuning and enter the correct information.
Results from Auto-Tuning are outside the parameter setting range or the tuning process took too long.		<ul style="list-style-type: none"> Check and correct faulty motor wiring. Perform Rotational Auto-Tuning.
The load was too high during Rotational Auto-tuning.		<ul style="list-style-type: none"> Disconnect the motor from machine and restart Auto-Tuning. If motor and load cannot be uncoupled make sure the load is lower than 30%. If a mechanical brake is installed, make sure it is fully lifted during tuning.

Digital Operator Display		Error Name
Er-08	Er-08	Rated Slip Error
Cause		Possible Solutions
Motor data entered during Auto-Tuning was incorrect.		<ul style="list-style-type: none"> Make sure the data entered to the T1 parameters match the information written on the motor nameplate. Restart Auto-Tuning and enter the correct information.
Results from Auto-Tuning are outside the parameter setting range or the tuning process took too long.		<ul style="list-style-type: none"> Check and correct faulty motor wiring. Perform Rotational Auto-Tuning.
The load was too high during rotational Auto-tuning.		<ul style="list-style-type: none"> Disconnect the motor from machine and restart Auto-Tuning. If motor and load cannot be uncoupled make sure the load is lower than 30%. If a mechanical brake is installed, make sure it is fully lifted during tuning.

Digital Operator Display		Error Name
Er-09	Er-09	Acceleration Error
Cause		Possible Solutions
The motor did not accelerate for the specified acceleration time.		<ul style="list-style-type: none"> Increase the acceleration time (C1-01). Disconnect the machine from the motor if possible.
Torque limit when motoring is too low (L7-01 and L7-02).		<ul style="list-style-type: none"> Check L7-01 and L7-02 settings. Increase the setting.
The load was too high during Rotational Auto-Tuning.		<ul style="list-style-type: none"> Disconnect the motor from machine and restart Auto-Tuning. If motor and load cannot be uncoupled make sure the load is lower than 30%. If a mechanical brake is installed, make sure it is fully lifted during tuning.

Digital Operator Display		Error Name
Er-10	Er-10	Motor Direction Error
Cause		Possible Solutions
The encoder signal lines are not properly connected to the drive.		Check and correct wiring to the PG encoder.
Motor direction and PG direction are opposite.		Check the motor speed monitor U1-05 while manually turning the motor forward. If the sign displayed is negative, change the setting of parameter F1-05.
The load pulled the motor in the opposite direction of the speed reference and the torque exceeded 100%.		Uncouple the motor from the load and restart Auto-Tuning.

Digital Operator Display		Error Name
Er-11	Er-11	Motor Speed Fault
Cause		Possible Solutions
Torque reference is too high.		<ul style="list-style-type: none"> Increase the acceleration time (C1-01). Disconnect the machine from the motor if possible.

Digital Operator Display		Error Name
Er-12	Er-12	Current Detection Error
Cause		Possible Solutions
One of the motor phases is missing: (U/T1, V/T2, W/T3).		Check motor wiring and correct any problems.
The current exceeded the current rating of the drive.		<ul style="list-style-type: none"> Check motor wiring for a short between motor lines. Close any magnetic contactors used between motors.
The current is too low.		<ul style="list-style-type: none"> Replace the control board or the entire drive. For instructions on replacing the control board, contact Yaskawa or your nearest sales representative.
Attempted Auto-Tuning without motor connected to the drive.		Connect the motor and restart Auto-Tuning.
Current detection signal error.		Replace the control board or the entire drive. For instructions on replacing the control board, contact Yaskawa or your nearest sales representative.

6.7 Auto-Tuning Fault Detection

Digital Operator Display		Error Name
<i>Er-13</i>	Er-13	Leakage Inductance Error
Cause		Possible Solutions
Drive was unable to complete tuning for leakage inductance within 300 seconds.		<ul style="list-style-type: none"> • Check all wiring and correct any mistakes. • Check the motor rated current value written on the motor nameplate and enter the correct value to T1-04.

Digital Operator Display		Error Name
<i>Er-14</i>	Er-14	Motor Speed Error 2
Cause		Possible Solutions
The motor speed exceeded twice the amplitude of speed reference during Inertia Tuning.		Reduce the ASR gain set to C5-01.

Digital Operator Display		Error Name
<i>Er-15</i>	Er-15	Torque Saturation Error
Cause		Possible Solutions
The output torque reached the torque limit set in L7-01 through L7-04 during Inertia Tuning.		<ul style="list-style-type: none"> • Increase the torque limits in L7-01 through L7-04 within reasonable limits. • Reduce the test signal amplitude in T3-01 and restart Auto-Tuning. If necessary, reduce the test signal frequency (T3-02) and restart Auto-Tuning.

Digital Operator Display		Error Name
<i>Er-16</i>	Er-16	Inertia Detection Error
Cause		Possible Solutions
The inertia identified by the drive was abnormally small or abnormally large during Inertia Tuning.		<ul style="list-style-type: none"> • Reduce the test signal amplitude in T3-01 and restart Auto-Tuning. If necessary, reduce the test signal frequency (T3-02) and restart Auto-Tuning. • Check the basic motor inertia value entered to T3-03.

Digital Operator Display		Error Name
<i>Er-17</i>	Er-17	Reverse Prohibited Error
Cause		Possible Solutions
Drive is prohibited from rotating the motor in reverse while attempting to perform Inertia Tuning.		<ul style="list-style-type: none"> • Inertia Auto-Tuning cannot be performed if the drive is restricted from rotating in reverse. • Assuming it is acceptable for the application to rotate in reverse, set b1-04 to 0 and then perform Inertia Tuning.

Digital Operator Display		Error Name
<i>Er-18</i>	Er-18	Induction Voltage Error
Cause		Possible Solutions
The result of Back EMF Constant Tuning (induced voltage) exceeds the allowable setting range.		Double-check the data entered to the T2-□□ parameters and restart Auto-Tuning.

Digital Operator Display		Error Name
<i>Er-19</i>	Er-19	PM Inductance Error
Cause		Possible Solutions
The induced voltage constant attempted to set a value to E5-08 or E5-09 that is outside the allowable range.		Double-check the data entered to the T2-□□ parameters and restart Auto-Tuning.

Digital Operator Display		Error Name
<i>Er-20</i>	Er-20	Stator Resistance Error
Cause		Possible Solutions
Stator resistance tuning attempted to set a value to E5-06 that is outside the allowable setting range.		Double-check the data entered to the T2-□□ parameters and restart Auto-Tuning.

Digital Operator Display		Error Name
<i>Er-21</i>	Er-21	Z Pulse Correction Error
Cause		Possible Solutions
Motor was coasting when Auto-Tuning was performed.		Make sure the motor has stopped completely. Restart Auto-Tuning.
Either the motor or the PG encoder on the motor are not properly wired.		Check the wiring for the motor and the PG encoder. Restart Auto-Tuning.
The direction for the PG encoder is set incorrectly, or the number of pulses set for the PG encoder is wrong.		Check the direction and number of pulses set for the PG encoder. Restart Auto-Tuning.
PG encoder is damaged.		Check the signal output from the PG encoder attached to the motor. Replace the PG if damaged.

6.8 Copy Function Related Displays

◆ Tasks, Errors, and Troubleshooting

The table below lists the messages and errors that may appear when using the Copy function.

When executing the tasks offered by the Copy function, the operator will indicate the task being performed. When an error occurs, a code appears on the operator to indicate the error. Note that errors related to the Copy function do not trigger a multi-function output terminal that has been set up to close when a fault or alarm occurs. To clear an error, simply press any key on the operator and the error display will disappear.

Table 6.18 lists the corrective action that can be taken when an error occurs.

- Note:**
1. Whenever using the copy function, the drive should be fully stopped.
 2. The drive will not accept a Run command while the Copy function is being executed.
 3. Parameters can only be saved to a drive when the voltage class, capacity, control mode, and software version match.

Table 6.18 Copy Function Task and Error Displays

Digital Operator Display		Task
<i>CoPY</i>	CoPy	Writing Parameter Settings (flashing)
Cause		Possible Solutions
Parameters are being written to the drive.		This is not an error.
Digital Operator Display		Task
<i>CPEr</i>	CPEr	Control Mode Mismatch
Cause		Possible Solutions
Control mode of the parameters to be loaded onto the drive and the control mode set to the drive do not match.		<ul style="list-style-type: none"> • Verify the control mode for the parameters to be loaded onto the drive and the control mode on drive to which those parameters will be written. • Set the same control mode using parameter A1-02 and retry.
Digital Operator Display		Task
<i>CPyE</i>	CPyE	Error Writing Data
Cause		Possible Solutions
Failed writing parameters		Attempt to write parameters again.
Digital Operator Display		Task
<i>CSEr</i>	CSEr	Copy Unit Error
Cause		Possible Solutions
Hardware fault		Replace the operator or the USB Copy Unit.
Digital Operator Display		Task
<i>dFPS</i>	dFPS	Drive Model Mismatch
Cause		Possible Solutions
The drives used in the copy and write process are not the same model. <ul style="list-style-type: none"> • The drive from which the parameters were copied is a different model. • The drive to be written to is a different model. 		<ul style="list-style-type: none"> • Verify the model number of the drive from which the parameters were copied and the model of the drive to which those parameters will be written. • Make sure the two drives are the same model and have the same software version.
Digital Operator Display		Task
<i>End</i>	End	Task Complete
Cause		Possible Solutions
Finished reading, writing, or verifying parameters.		This is not an error.
Digital Operator Display		Task
<i>iFEr</i>	iFEr	Communication Error
Cause		Possible Solutions
A communication error occurred between the drive and the operator or the USB copy unit.		Check the cable connection.

A non-compatible cable is being used to connect the USB Copy Unit and the drive.	Use the cable originally packaged with the USB Copy Unit.
--	---

Digital Operator Display		Task
<i>ndRf</i>	ndAT	Model, Voltage Class, Capacity Mismatch
Cause		Possible Solutions
The drive from which the parameters were copied and the drive to which the parameters will be written have different electrical specifications, capacities, are set to different control modes, or are different models.		Make sure model numbers and specifications are the same for both drives.
The device being used to write the parameters is blank and does not have any parameters saved on it.		Make sure all connections are correct, and copy the parameter settings onto the USB Copy Unit or the operator.

Digital Operator Display		Task
<i>rdEr</i>	rdEr	Error Reading Data
Cause		Possible Solutions
Failed while attempting to read parameter settings from the drive.		Press and hold the READ key on the USB Copy Unit for at least one second to have the unit read parameters from the drive.

Digital Operator Display		Task
<i>rERd</i>	rEAd	Reading Parameter Settings (flashing)
Cause		Possible Solutions
Displayed while the parameter settings are being read onto the USB Copy Unit.		This is not an error.

Digital Operator Display		Task
<i>vAEr</i>	vAEr	Voltage Class, Capacity Mismatch
Cause		Possible Solutions
The drive from which the parameters were copied and the drive on which the Verify mode is being performed have different electrical specifications or are a different capacity.		Make sure electrical specifications and capacities are the same for both drives.

Digital Operator Display		Task
<i>vFyE</i>	vFyE	Parameter settings in the drive and those saved to the copy function are not the same
Cause		Possible Solutions
Indicates that parameter settings that have been Read and loaded onto the Copy Unit or Digital Operator are different.		To synchronize parameters, either write the parameters saved on the USB Copy Unit or digital operator onto the drive, or Read the parameter settings on the drive onto the USB Copy Unit.

Digital Operator Display		Task
<i>vrFy</i>	vrFy	Comparing Parameter Settings (flashing)
Cause		Possible Solutions
The Verify mode has confirmed that parameters settings on the drive and parameters read to the copy device are identical.		This is not an error.

6.9 Diagnosing and Resetting Faults

When a fault occurs and the drive stops, follow the instructions below to remove whatever conditions triggered the fault, then restart the drive.

Note: An oC/SC fault will be displayed in the event of an IGBT failure. It may not be possible to reset this fault until the IGBT problem is corrected.

◆ Fault Occurs Simultaneously with Power Loss

WARNING! Electrical Shock Hazard. Ensure there are no short circuits between the main circuit terminals (R/L1, S/L2, and T/L3) or between the ground and main circuit terminals before restarting the drive. Failure to comply may result in serious injury or death and will cause damage to equipment.

1. Turn on the drive input power.
2. Use monitor parameters U2-□□ to display data on the operating status of the drive just before the fault occurred.
3. Remove the cause of the fault and reset.







Note:

1. To find out what faults were triggered, check the fault history in U2-02. Information on drive status when the fault occurred such as the frequency, current, and voltage can be found in U2-03 through U2-20. [Refer to Viewing Fault Trace Data After Fault on page 386](#) for information on how to view fault data.
2. When the fault continues to be displayed after cycling power, remove the cause of the fault and reset.

◆ If the Drive Still has Power After a Fault Occurs

1. Look at the digital operator for information on the fault that occurred.
2. [Refer to Fault Displays, Causes, and Possible Solutions on page 347.](#)
3. Reset the fault. [Refer to Fault Reset Methods on page 387.](#)

◆ Viewing Fault Trace Data After Fault

Step		Display/Result
1. Turn on the drive input power. The first screen displays.	→	<pre> - MODE - DRV Rdy FREQ (OPR) U1-01= 0.00Hz U1-02= 0.00Hz[LSEQ U1-03= 0.00A [LREF NOG FWD FWD/REV </pre>
2. Press  or  until the monitor screen is displayed.	→	<pre> - MODE - DRV Rdy Monitor Menu U1-01= 0.00Hz U1-02= 0.00Hz[LSEQ U1-03= 0.00A [LREF NOG FWD FWD/REV </pre>
3. Press  to display the parameter setting screen.	→	<pre> -MONITR- DRV Rdy Monitor U1-01= 0.00Hz U1-02= 0.00Hz[LSEQ U1-03= 0.00A [LREF NOG FWD FWD/REV </pre>
4. Press  and  to scroll to monitor U2-02. The fault code shown in U2-02 is the fault that occurred most recently.	→	<pre> - MONITR - DRV Rdy Last Fault U2-02= oC U2-03= 0.00Hz[LSEQ U2-04= 0.00Hz[LREF NOG FWD FWD/REV </pre>
5. Press  to view drive status information when fault occurred. Parameters U2-03 through U2-20 help determine the cause of a fault. Parameters to be monitored differ depending on the control mode.	→	<pre> - MONITR - DRV Rdy Frequency Ref U2-03= 0.00Hz U2-04= 0.00Hz[LSEQ U2-05= 0.00A [LREF NOG FWD FWD/REV ↓ ↓ ↓ - MONITR - DRV Rdy Heatsink Temp U2-20= XX °C U2-01= ---- [LSEQ U2-02= ---- [LREF NOG FWD FWD/REV </pre>

◆ **Fault Reset Methods**

When a fault occurs, the cause of the fault must be removed and the drive must be restarted. The table below lists the different ways to restart the drive.

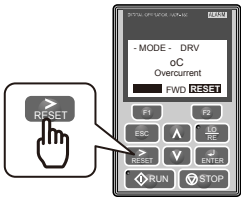
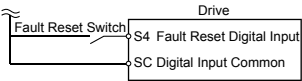
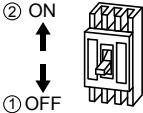
After the Fault Occurs	Procedure	
Fix the cause of the fault, restart the drive, and reset the fault	Press  on the digital operator when the error code is displayed.	
Resetting via Fault Reset Digital Input S4	Close then open the fault signal digital input via terminal S4. S4 is set for “Fault Reset” as default (H1-04 = 14).	
Turn off the main power supply if the above methods do not reset the fault. Reapply power after the digital operator display has turned off.		

Note: If the Run command is present, the drive will disregard any attempts to reset the fault. Remove the Run command before attempting to clear a fault situation.

6.10 Troubleshooting without Fault Display

This section describes troubleshooting problems that do not trip an alarm or fault.

The following symptoms indicate that the drive is not set correctly for proper performance with the motor. *Refer to Motor Performance Fine-Tuning on page 336* for guidance on troubleshooting.



- Motor hunting and oscillation
- Poor motor torque
- Poor speed precision
- Poor motor torque and speed response
- Motor noise

◆ Common Problems

Common Problems		Page
Cannot Change Parameter Settings		388
Motor Does Not Rotate Properly after Pressing RUN Button or after Entering External Run Command	Motor Does Not Rotate	389
	Motor Rotates in the Opposite Direction from the Run Command	390
	Motor Rotates in One Direction Only	390
Motor is Too Hot		390
Drive Does Not Allow Selection of Rotational Auto-Tuning		391
oPE02 Error Occurs When Lowering the Motor Rated Current Setting		391
Motor Stalls During Acceleration or With Large Loads		391
Drive Frequency Reference Differs from the Controller Frequency Reference Command		392
Excessive Motor Oscillation and Erratic Rotation		392
Deceleration Takes Longer Than Expected with Dynamic Braking Enabled		392
Noise From Drive or Motor Cables When the Drive is Powered On		393
Ground Fault Circuit Interrupter (GFCI) Trips During Run		393
Connected Machinery Vibrates When Motor Rotates	Unexpected Noise from Connected Machinery	393
	Oscillation or Hunting	393
PID Output Fault		394
Insufficient Starting Torque		394
Motor Rotates After the Drive Output is Shut Off (Motor Rotates During DC Injection Braking)		394
Output Frequency is not as High as Frequency Reference		394
Buzzing Sound from Motor at 2 kHz		394
Unstable Motor Speed when Using PM or IPM		395
Motor Does Not Restart after Power Loss		395



◆ Cannot Change Parameter Settings

Cause	Possible Solutions
The drive is running the motor (i.e., the Run command is present).	<ul style="list-style-type: none"> • Stop the drive and switch over to the Programming Mode. • Most parameters cannot be edited during run.
The Access Level is set to restrict access to parameter settings.	<ul style="list-style-type: none"> • Set the Access Level to allow parameters to be edited (A1-01 = 2).
The operator is not in the Parameter Setup Mode (the screen will display “PAR”).	<ul style="list-style-type: none"> • See what mode the operator is currently set for. • Parameters cannot be edited when in the Setup Mode (“STUP”). Switch modes so that “PAR” appears on the screen. <i>Refer to The Drive and Programming Modes on page 120.</i>
A multi-function contact input terminal is set to allow or restrict parameter editing (H1-01 through H1-08 = 1B).	<ul style="list-style-type: none"> • When the terminal is open, parameters cannot be edited. • Turn on the multi-function contact input set to 1B.



Cause	Possible Solutions
The wrong password was entered.	<ul style="list-style-type: none"> If the password entered to A1-04 does not match the password saved to A1-05, then drive settings cannot be changed. Reset the password. <p>If you cannot remember the password:</p> <ul style="list-style-type: none"> Scroll to A1-04. Press  and  simultaneously. Parameter A1-05 will appear. Set a new password to parameter A1-05.
Undervoltage was detected.	<ul style="list-style-type: none"> Check the drive input power voltage by looking at the DC bus voltage (U1-07). Check all main circuit wiring.

◆ Motor Does Not Rotate Properly after Pressing RUN Button or after Entering External Run Command

■ Motor Does Not Rotate

Cause	Possible Solutions
The drive is not in the Drive Mode.	<ul style="list-style-type: none"> Check if the DRV light on the digital operator is lit. Enter the Drive Mode to begin operating the motor. <i>Refer to The Drive and Programming Modes on page 120.</i>
 was pushed.	<p>Stop the drive and check if the correct frequency reference source is selected. If the operator keypad shall be the source, the LO/RE button LED must be on. If the source is REMOTE, it must be off.</p> <p>Take the following steps to solve the problem:</p> <ul style="list-style-type: none"> Push . If o2-01 is set to 0, then the LO/RE button will be disabled.
Auto-Tuning has just completed.	<ul style="list-style-type: none"> When Auto-Tuning completes, the drive is switched back to the Programming Mode. The Run command will not be accepted unless the drive is in the Drive Mode. Use the digital operator to enter the Drive Mode. <i>Refer to The Drive and Programming Modes on page 120.</i>
A Fast Stop was executed and has not yet been reset.	Reset the Fast Stop command.
Settings are incorrect for the source that provides the Run command.	<p>Check parameter b1-02 (Run Command Selection). Set b1-02 so that it corresponds with the correct Run command source.</p> <p>0: Digital operator 1: Control circuit terminal (default setting) 2: MEMOBUS/Modbus communications 3: Option card</p>
There is faulty wiring in the control circuit terminals.	<ul style="list-style-type: none"> Check the wiring for the control terminal. Correct wiring mistakes. Check the input terminal status monitor (U1-10).
The drive has been set to accept the frequency reference from the incorrect source.	<p>Check parameter b1-01 (Frequency Reference Selection 1). Set b1-01 to the correct source of the frequency reference.</p> <p>0: Digital operator 1: Control circuit terminal (default setting) 2: MEMOBUS/Modbus communications 3: Option card 4: Pulse train input (RP)</p>
The terminal set to accept the main speed reference is set to the incorrect voltage and/or current.	If the frequency reference is set at terminal A1, check parameter H3-01 for the correct signal level selection. If terminal A2 is used, check DIP switch S1 parameter H3-08. If terminal A3 is used, check parameter H3-08. <i>Refer to Terminal A2 Input Signal Selection on page 106.</i>
Selection for the sink/source mode and the internal/external power supply is incorrect.	Check jumper S3. <i>Refer to Sinking/Sourcing Mode Switch for Digital Inputs on page 104.</i>
Frequency reference is too low.	<ul style="list-style-type: none"> Check the frequency reference monitor (U1-01). Increase the frequency by changing the maximum output frequency (E1-09).
Multi-function analog input is set up to accept gain for the frequency reference, but no voltage (current) has been provided.	<ul style="list-style-type: none"> Check the multi-function analog input settings. Check if analog input A1, A2, or A3 is set for frequency reference gain (H3-02, H3-10, H3-06 = 1). If so, check if the correct signal is applied to the terminal. The gain and the frequency reference will be 0 if no signal is applied to the gain input. Check if H3-02, H3-10, and H3-06 have been set to the proper values. Check if the analog input value has been set properly. (U1-13 to U1-15)

6.10 Troubleshooting without Fault Display

Cause	Possible Solutions
 was pressed when the drive was started from a REMOTE source.	<ul style="list-style-type: none"> Pressing  will decelerate the drive to stop. Switch off the Run command and then re-enter a new Run command. Set o2-02 to 0 to disable .
Motor starting torque is too low.	<i>Refer to Motor Performance Fine-Tuning on page 336.</i>
Frequency reference value is too low or the drive does not accept the value entered.	Enter a value that is above the minimum output frequency determined by E1-09.
The sequence Start/Stop sequence is set up incorrectly.	<ul style="list-style-type: none"> If the drive is supposed to be set up for a 2-wire sequence, then ensure parameters H1-03 through H1-08 are not set to 0. If the drive is supposed to be set up for a 3-wire sequence, then one of the parameters H1-03 through H1-08 must be set to 0. Terminal S1 will become the Start, terminal S2 will become the Stop input.

■ Motor Rotates in the Opposite Direction from the Run Command

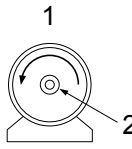
Cause	Possible Solutions
Phase wiring between the drive and motor is incorrect.	<ul style="list-style-type: none"> Check the motor wiring. Switch two motor cables (U, V, and W) to reverse motor direction. Connect drive output terminals U/T1, V/T2, and W/T3 in the right order to match motor terminals U, V, and W. Change the setting of parameter b1-14.
The forward direction for the motor is set up incorrectly.	<p>Typically, forward is designated as being counterclockwise when looking from the motor shaft (see figure below).</p>  <ol style="list-style-type: none"> Forward Rotating Motor (looking down the motor shaft) Motor Shaft
The motor is running at almost 0 Hz and the Speed Search estimated the speed to be in the opposite direction.	<ul style="list-style-type: none"> Disable bi-directional search (b3-14 = 0) so that Speed Search is performed only in the specified direction.

Note: Check the motor specifications for the forward and reverse directions. The motor specifications will vary depending on the manufacturer of the motor.

■ Motor Rotates in One Direction Only

Cause	Possible Solutions
The drive prohibits reverse rotation.	<ul style="list-style-type: none"> Check parameter b1-04. Set parameter b1-04 to 0 to allow the motor to rotate in reverse.
A Reverse run signal has not been entered, although 3-Wire sequence is selected.	<ul style="list-style-type: none"> Make sure that one of the input terminals S3 to S8 used for the 3-Wire sequence has been set for reverse.

◆ Motor is Too Hot

Cause	Possible Solutions
The load is too heavy.	<p>If the load is too heavy for the motor, the motor will overheat as it exceeds its rated torque value for an extended period of time. Keep in mind that the motor also has a short-term overload rating in addition to the possible solutions provided below:</p> <ul style="list-style-type: none"> Reduce the load. Increase the acceleration and deceleration times. Check the values set for the motor protection (L1-01, L1-02) as well as the motor rated current (E2-01). Increase motor capacity.
The air around the motor is too hot.	<ul style="list-style-type: none"> Check the ambient temperature. Cool the area until it is within the specified temperature range.

Cause	Possible Solutions
The drive is operating in a vector control mode but Auto-Tuning has not yet been performed.	<ul style="list-style-type: none"> Perform Auto-Tuning. Calculate the motor value and reset the motor parameters. Change the motor control method to V/f Control (A1-02 = 0).
Insufficient voltage insulation between motor phases.	<p>When the motor cable is long, high voltage surges occur between the motor coils and drive switching. Normally, surges can reach up to three times the drive input power supply voltage.</p> <ul style="list-style-type: none"> Use a motor with a voltage tolerance higher than the max voltage surge. Use an inverter-duty motor rated for use with AC drives when using the motor on drives rated higher than 200 V class. Install an AC reactor on the output side of the drive. The carrier frequency should be set to 2 kHz when installing an AC reactor.
The motor fan has stopped or is clogged.	Check the motor fan.
The carrier frequency is too low.	Increase the carrier frequency to lower the current harmonic distortion and lower the motor temperature.

◆ Drive Does Not Allow Selection of the Desired Auto-Tuning Mode

Cause	Possible Solutions
The desired Auto-Tuning mode is not available for the selected control mode.	<ul style="list-style-type: none"> Check if the desired tuning mode is available for the selected control mode. <i>Refer to Auto-Tuning on page 135.</i> Change the motor control method by setting A1-02.

◆ oPE02 Error Occurs When Lowering the Motor Rated Current Setting

Cause	Possible Solutions
Motor rated current and the motor no-load current setting in the drive are incorrect.	<ul style="list-style-type: none"> The user is trying to set the motor rated current in E2-01 to a value lower than the no-load current set in E2-03. Make sure that value set in E2-01 is higher than E2-03. If it is necessary to set E2-01 lower than E2-03, first lower the value set to E2-03, then change the setting in E2-01 as needed.

◆ Motor Stalls during Acceleration or Acceleration Time is Too Long

Cause	Possible Solutions
Torque limit has been reached or current suppression keeps the drive from accelerating.	Take the following steps to resolve the problem:
Load is too heavy.	<ul style="list-style-type: none"> Reduce the load. Increase motor capacity. <p>Note: Although the drive has a Stall Prevention function and a Torque Compensation Limit function, accelerating too quickly or trying to drive an excessively large load can exceed the capabilities of the motor.</p>
Torque limit is not set properly.	Check the torque limit setting.
Frequency reference is too low.	<ul style="list-style-type: none"> Check the maximum output frequency (E1-04). Increase E1-04 if it is set too low. <p>Check U1-01 for proper frequency reference.</p> <p>Check if a frequency reference signal switch has been set to one of the multi-function input terminals.</p> <p>Check for low gain level set to terminals A1, A2, or A3 (H3-03, H3-11, H3-07).</p>
Load is too heavy.	<ul style="list-style-type: none"> Reduce the load so that the output current remains within the motor rated current. In extruder and mixer applications, the load will sometimes increase as the temperature drops. Increase the acceleration time. Check if the mechanical brake is fully releasing as it should.
Acceleration time has been set too long.	Check if the acceleration time parameters have been set too long (C1-01, C1-03, C1-05, C1-07).
Motor characteristics and drive parameter settings are incompatible with one another.	<ul style="list-style-type: none"> Set the correct V/f pattern so that it matches the characteristics of the motor being used. Check the V/f pattern set to E1-03. Execute Rotational Auto-Tuning.

6.10 Troubleshooting without Fault Display

Cause	Possible Solutions
Although the drive is operating in Open Loop Vector motor control method, Auto-Tuning has not been performed.	<ul style="list-style-type: none"> Perform Auto-Tuning. Calculate motor data and reset motor parameters. Switch to V/f Control (A1-02 = 0).
Incorrect frequency reference setting.	<ul style="list-style-type: none"> Check the multi-function analog input settings. Multi-function analog input terminal A1, A2, or A3 is set for frequency gain (H3-02, H3-10, or H3-06 is set to "1"), but there is no voltage or current input provided. Make sure H3-02, H3-10, and H3-06 are set to the proper values. See if the analog input value is set to the right value (U1-13 to U1-15).
The Stall Prevention level during acceleration and deceleration set too low.	<ul style="list-style-type: none"> Check the Stall Prevention level during acceleration (L3-02). If L3-02 is set too low, acceleration may be taking too long. Increase L3-02.
The Stall Prevention level during run has been set too low.	<ul style="list-style-type: none"> Check the Stall Prevention level during run (L3-06). If L3-06 is set too low, speed will drop as the drive outputs torque. Increase the setting value.
Drive reached the limitations of the V/f motor control method.	<ul style="list-style-type: none"> The motor cable may be long enough (over 50 m) to require Auto-Tuning for line-to-line resistance. Be aware that V/f Control is comparatively limited when it comes to producing torque at low speeds. Consider switching to Open Loop Vector Control.

◆ Drive Frequency Reference Differs from the Controller Frequency Reference Command

Cause	Possible Solutions
The analog input gain and bias for the frequency reference input are set to incorrect values.	<ul style="list-style-type: none"> Check the gain and bias settings for the analog inputs that are used to set the frequency reference. Check parameters H3-03 and H3-04 for input A1, check parameters H3-11 and H3-12 for input A2, and check parameters H3-07 and H3-08 for input A3. Set these parameters to the appropriate values.
A frequency bias signal is being entered via analog input terminals A1 to A3.	<ul style="list-style-type: none"> If more than one of multi-function analog inputs A1 to A3 is set for frequency reference bias (H3-02, H3-10, or H3-06 is set to "0"), then the sum of all signals builds the frequency reference. Make sure that H3-02, H3-10, and H3-06 are set appropriately. Check the input level set for terminals A1 to A3 (U1-13 to U1-15).
PID control is enabled, and the drive is consequently adjusting the output frequency to match the PID setpoint. The drive will only accelerate to the maximum output frequency set in E1-04 while PID control is active.	If PID control is not necessary for the application, disable it by setting b5-01 to 0.

◆ Excessive Motor Oscillation and Erratic Rotation

Cause	Possible Solutions
Poor balance between motor phases.	Check drive input power voltage to ensure that it provides stable power.
Hunting prevention function is disabled.	<ul style="list-style-type: none"> Enable Hunting Prevention (n1-01 = 1). Increase the AFR gain (n2-01) or the AFR time constant (n2-02).

◆ Deceleration Takes Longer Than Expected with Dynamic Braking Enabled

Cause	Possible Solutions
L3-04 is set incorrectly.	<ul style="list-style-type: none"> Check the Stall Prevention level during deceleration (L3-04). If a dynamic braking option has been installed, disable Stall Prevention during deceleration (L3-04 = 0).
The deceleration time is set too long.	Set deceleration to more appropriate time (C1-02, C1-04, C1-06, C1-08).
Insufficient motor torque.	<ul style="list-style-type: none"> Assuming parameter settings are normal and that no overvoltage occurs when there is insufficient torque, it is likely that the demand on the motor has exceeded the motor capacity. Use a larger motor.

Cause	Possible Solutions
Reaching the torque limit.	<ul style="list-style-type: none"> • Check the settings for the torque limit (L7-01 through L7-04). • If the torque limit is enabled, deceleration might take longer than expected because the drive cannot output more torque than the limit setting. Ensure the torque limit is set to a high enough value. • Increase the torque limit setting.
Load exceeded the internal torque limit determined by the drive rated current.	<ul style="list-style-type: none"> • If multi-function analog input terminal A1, A2, or A3 is set to torque limit (H3-02, H3-10, or H3-06 equals 10, 11, 12, or 15), ensure that the analog input levels are set to the correct levels. • Ensure H3-02, H3-10, and H3-06 are set to the right levels. • Ensure the analog input is set to the correct value (U1-13 to U1-15).
	Switch to a larger capacity drive.

◆ **Noise From Drive or Motor Cables When the Drive is Powered On**

Cause	Possible Solutions
Relay switching in the drive generates excessive noise.	<ul style="list-style-type: none"> • Lower the carrier frequency (C6-02). • Install a noise filter on the input side of drive input power. • Install a noise filter on the output side of the drive. • Place the wiring inside a metal conduit to shield it from switching noise. • Ground the drive and motor properly. • Separate the main circuit wiring and the control lines. • Make sure wires and the motor have been properly grounded.

◆ **Ground Fault Circuit Interrupter (GFCI) Trips During Run**

Cause	Possible Solutions
Excessive leakage current trips GFCI.	<ul style="list-style-type: none"> • Check the wiring and rating of peripheral devices. • Increase the GFCI sensitivity or use GFCI with a higher threshold. • Lower the carrier frequency (C6-02). • Reduce the length of the cable used between the drive and the motor. • Install a noise filter or reactor on the output side of the drive. Set the carrier frequency to 2 kHz when connecting a reactor. • Disable the internal EMC filter.

◆ **Connected Machinery Vibrates When Motor Rotates**

■ **Unexpected Noise from Connected Machinery**

Cause	Possible Solutions
The carrier frequency is at the resonant frequency of the connected machinery.	Adjust the carrier frequency using parameters C6-02 through C6-05.
The drive output frequency is the same as the resonant frequency of the connected machinery.	<ul style="list-style-type: none"> • Adjust the parameters used for the Jump frequency function (d3-01 through d3-04) to skip the problem-causing bandwidth. • Place the motor on a rubber pad to reduce vibration.

Note: The drive may have trouble assessing the status of the load due to white noise generated from using Swing PWM (C6-02 = 7 to A).

■ **Oscillation or Hunting**

Cause	Possible Solutions
Insufficient tuning.	Perform Auto-Tuning. <i>Refer to Motor Performance Fine-Tuning on page 336.</i>
Gain is too low when using PID control.	<i>Refer to b5: PID Control on page 179 for details.</i>
The frequency reference is assigned to an external source and the signal is noisy.	<ul style="list-style-type: none"> • Ensure that noise is not affecting the signal lines. • Separate main circuit wiring and control circuit wiring. • Use twisted-pair cables or shielded wiring for the control circuit. • Increase the analog input time filter constant (H3-13).
The cable between the drive and motor is too long.	<ul style="list-style-type: none"> • Perform Auto-Tuning. • Reduce the length of the cable.

6.10 Troubleshooting without Fault Display

◆ PID Output Fault

Cause	Possible Solutions
No PID feedback input.	<ul style="list-style-type: none"> Check the multi-function analog input terminal settings. Set multi-function analog input terminal A1, A2, or A3 for PID feedback (H3-02, H3-10, or H3-06 = "B"). A signal input to the terminal selection for PID feedback is needed. Check the connection of the feedback signal. Check the various PID-related parameter settings. No PID feedback input to the terminal causes the value detected to be 0, causing a PID fault and the drive to operate at max frequency.
The level of detection and the target value do not correspond with each other.	<ul style="list-style-type: none"> PID control keeps the difference between target and detection values at 0. Set the input level for the values relative to one another. Use analog input gains H3-03 and H3-11 to adjust PID target and feedback signal scaling.
Reverse drive output frequency and speed detection. When output frequency rises, the sensor detects a speed decrease.	Set PID output for reverse characteristics (b5-09 = 1).
Adjustment made to PID parameter settings are insufficient.	<i>Refer to b5: PID Control on page 179</i> for details.

◆ Insufficient Starting Torque

Cause	Possible Solutions
Auto-Tuning has not yet been performed (required for vector control modes).	Perform Auto-Tuning. <i>Refer to Motor Performance Fine-Tuning on page 336.</i>
The control mode was changed after performing Auto-Tuning.	Perform Auto-Tuning again.
Only Stationary Auto-Tuning was performed.	Perform Rotational Auto-Tuning.

◆ Motor Rotates After the Drive Output is Shut Off (Motor Rotates During DC Injection Braking)

Cause	Possible Solutions
DC Injection Braking is set too low and the drive cannot decelerate properly.	<ul style="list-style-type: none"> Adjust the DC Injection braking settings. Increase the current level for DC Injection Braking (b2-02). Increase the DC Injection Braking time at stop (b2-04).
The stopping method is set so that the drive coasts to stop.	Set b1-03 (Stopping Method Selection) to 0 or 2.

◆ Output Frequency is Not as High as Frequency Reference

Cause	Possible Solutions
Frequency reference is set within the range of the Jump frequency.	<ul style="list-style-type: none"> Adjust the parameters used for the Jump frequency function (d3-01, d3-02, d3-03). Enabling the Jump frequency prevents the drive from outputting the frequencies specified in the Jump range.
Upper limit for the frequency reference has been exceeded.	<ul style="list-style-type: none"> Set the maximum output frequency and the upper limit for the frequency reference to more appropriate values (E1-04, d2-01). The following calculation yields the upper value for the output frequency: $E1-04 \times d2-01 / 100$
Large load triggered Stall Prevention function during acceleration.	<ul style="list-style-type: none"> Reduce the load. Adjust the Stall Prevention level during acceleration (L3-02).

◆ Sound from Motor

Cause	Possible Solutions
Exceeded 110% of the rated output current of the drive while operating at low speeds.	<ul style="list-style-type: none"> If the output current rises too high at low speeds, the carrier frequency is automatically reduced and causes a whining or buzzing sound. If the sound is coming from the motor, disable carrier frequency derating (L8-38 = 0). Disabling the automatic carrier frequency derating increases the chances of an overload fault (oL2). Switch to a larger capacity motor if oL2 faults occur too frequently.

◆ Unstable Motor Speed when Using PM

Cause	Possible Solutions
The motor code for the PM motor (E5-01 or T2-02) is set incorrectly (Yaskawa motors only).	<i>Refer to Motor Performance Fine-Tuning on page 336</i> for details.
Drive is attempting to operate the motor beyond the speed control range listed in the specifications.	Check the speed control range and adjust the speed accordingly.
Motor hunting occurs.	<i>Refer to Motor Performance Fine-Tuning on page 336</i> for details.
Hunting occurs at start.	Increase the S-curve time at the start of acceleration (C2-01).
Too much current is flowing through the drive.	<ul style="list-style-type: none"> • Enter the correct motor code for the PM motor being used into E5-01. • For special-purpose motors, enter the correct data to all E5 parameters according to the test report provided for the motor.

◆ Motor Does Not Restart after Power Loss

Cause	Possible Solutions
The Run command was not issued again when power was restored.	<ul style="list-style-type: none"> • Check the sequence and wiring that has been set up to enter the Run command. • A relay should be set up to make sure the Run command remains enabled throughout any power loss.
The relay that is supposed to maintain the Run command has been switched off.	Check wiring and circuitry for the relay intended to keep the Run command enabled.

This Page Intentionally Blank

Periodic Inspection & Maintenance

This chapter describes the periodic inspection and maintenance of the drive to ensure that it receives the proper care to maintain overall performance.

7.1	SECTION SAFETY.....	398
7.2	INSPECTION.....	400
7.3	PERIODIC MAINTENANCE.....	403
7.4	DRIVE COOLING FANS.....	405
7.5	REPLACING THE AIR FILTER.....	430
7.6	DRIVE REPLACEMENT.....	432

7.1 Section Safety

WARNING

Electrical Shock Hazard

Do not connect or disconnect wiring while the power is on.

Failure to comply could result in death or serious injury.

Before servicing, disconnect all power to the equipment. The internal capacitor remains charged even after the power supply is turned off. The charge indicator LED will extinguish when the DC bus voltage is below 50 Vdc. To prevent electric shock, wait for at least the time specified on the warning label; after all indicators are OFF, measure for unsafe voltages to confirm the drive is safe prior to servicing.

Do not operate equipment with covers removed.

Failure to comply could result in death or serious injury.

The diagrams in this section may show drives without covers or safety shields to show details. Be sure to reinstall covers or shields before operating the drives and run the drives according to the instructions described in this manual.

Always ground the motor-side grounding terminal.

Improper equipment grounding could result in death or serious injury by contacting the motor case.

Do not remove covers or touch circuit boards while the power is on.

Failure to comply could result in death or serious injury.

Do not allow unqualified personnel to perform work on the drive.

Failure to comply could result in death or serious injury.

Installation, maintenance, inspection, and servicing must be performed only by authorized personnel familiar with installation, adjustment, and maintenance of AC drives.

Do not perform work on the drive while wearing loose clothing, jewelry or without eye protection.

Failure to comply could result in death or serious injury.

Remove all metal objects such as watches and rings, secure loose clothing, and wear eye protection before beginning work on the drive.

Do not touch any terminals before the capacitors have fully discharged.

Failure to comply could result in death or serious injury.

Before servicing, disconnect all power to the equipment. The internal capacitor remains charged even after the power supply is turned off. The charge indicator LED will extinguish when the DC bus voltage is below 50 Vdc. To prevent electric shock, wait for at least the time specified on the warning label; after all indicators are OFF, measure the DC bus voltage level to confirm it has reached a safe level.

Fire Hazard

Tighten all terminal screws to the specified tightening torque.

Loose electrical connections could result in death or serious injury by fire due to overheating of electrical connections.

Do not use an improper voltage source.

Failure to comply could result in death or serious injury by fire.

Verify that the rated voltage of the drive matches the voltage of the incoming power supply before applying power.

Do not use improper combustible materials.

Failure to comply could result in death or serious injury by fire.

Attach the drive to metal or other noncombustible material.

NOTICE**Observe proper electrostatic discharge procedures (ESD) when handling the drive and circuit boards.**

Failure to comply may result in ESD damage to the drive circuitry.

Follow cooling fan replacement instructions. The cooling fan cannot operate properly when it is installed incorrectly and could seriously damage the drive.

Follow the instructions in this manual to replace the cooling fan, making sure that the label is on top before inserting the cooling fan into the drive. To ensure maximum useful product life, replace both cooling fans when performing maintenance.

Never connect or disconnect the motor from the drive while the drive is outputting voltage.

Improper equipment sequencing could result in damage to the drive.

Do not use unshielded cable for control wiring.

Failure to comply may cause electrical interference resulting in poor system performance. Use shielded, twisted-pair wires and ground the shield to the ground terminal of the drive.

Do not allow unqualified personnel to use the product.

Failure to comply could result in damage to the drive or braking circuit.

Maintenance, inspection, and replacement of parts must be performed only by authorized personnel familiar with installation, adjustment and maintenance of AC drives.

Do not modify the drive circuitry.

Failure to comply could result in damage to the drive and will void warranty.

Yaskawa is not responsible for any modification of the product made by the user. This product must not be modified.

Check all the wiring to ensure that all connections are correct after installing the drive and connecting any other devices.

Failure to comply could result in damage to the drive.

Comply with proper wiring practices.

The motor may run in reverse if the phase order is backward.

Connect motor input terminals U, V and W to drive output terminals U/T1, V/T2, and W/T3. The phase order for the drive and motor should match.

Frequently switching the drive power supply to stop and start the motor can damage the drive.

To get the full performance life out of the electrolytic capacitors and circuit relays, refrain from switching the drive power supply off and on more than once every 30 minutes. Frequent use can damage the drive. Use the drive to stop and start the motor.

Do not operate damaged equipment.

Failure to comply could result in further damage to the equipment.

Do not connect or operate any equipment with visible damage or missing parts.

7.2 Inspection

Power electronics have limited life and may exhibit changes in characteristics or performance deterioration after years of use under normal conditions. To help avoid such problems, it is important to perform preventive maintenance and periodic inspection on the drive.

Drives contain a variety of power electronics such as power transistors, semiconductors, capacitors, resistors, fans, and relays. The electronics in the drive serve a critical role in maintaining proper motor control.

Follow the inspection lists provided in this chapter as a part of a regular maintenance program.

Note: The drive will require more frequent inspection if it is placed in harsh environments, such as:

- High ambient temperatures
- Frequent starting and stopping
- Fluctuations in the AC supply or load
- Excessive vibrations or shock loading
- Dust, metal dust, salt, sulfuric acid, chlorine atmospheres
- Poor storage conditions.

Perform the first equipment inspection one to two years after installation.

◆ Recommended Daily Inspection

Table 7.1 outlines the recommended daily inspection for Yaskawa drives. Check the following items on a daily basis to avoid premature deterioration in performance or product failure. Copy this checklist and mark the “Checked” column after each inspection.

Table 7.1 General Recommended Daily Inspection Checklist

Inspection Category	Inspection Points	Corrective Action	Checked
Motor	Inspect for abnormal oscillation or noise coming from the motor.	<ul style="list-style-type: none"> • Check the load coupling. • Measure motor vibration. • Tighten all loose components. 	
Cooling	Inspect for abnormal heat generated from the drive or motor and visible discoloration.	Check for the following: <ul style="list-style-type: none"> • Excessive load. • Loose connections. • Dirty heatsink or motor. • Ambient temperature. 	
	Inspect drive cooling fan and circulation fan operation.	Check for the following: <ul style="list-style-type: none"> • Clogged or dirty fan. • Correct Fan operation parameter setting. 	
Environment	Verify the drive environment complies with the specifications listed in <i>Installation Environment</i> on page 54.	Eliminate the source of contaminants or correct poor environment.	
Load	The drive output current should not be higher than the motor or drive rating for an extended period of time.	Check for the following: <ul style="list-style-type: none"> • Excessive load. • Correct motor parameter settings. 	
Power Supply Voltage	Check main power supply and control voltages.	<ul style="list-style-type: none"> • Correct the voltage or power supply to within nameplate specifications. • Verify all main circuit phases. 	

◆ Recommended Periodic Inspection

Table 7.2 outlines the recommended periodic inspections for Yaskawa drive installations. Although periodic inspections should generally be performed once a year; the drive may require more frequent inspection in harsh environments or with rigorous use. Operating and environmental conditions, along with experience in each application, will determine the actual inspection frequency for each installation. Periodic inspection will help to avoid premature deterioration in performance or product failure. Copy this checklist and mark the “Checked” column after each inspection.

■ Periodic Inspection

WARNING! Electrical Shock Hazard. Do not inspect, connect, or disconnect any wiring while the power is on. Failure to comply can result in serious personal injury. Before servicing, disconnect all power to the equipment. The internal capacitor remains charged even after the power supply is turned off. The charge indicator LED will extinguish when the DC bus voltage is below 50 Vdc. To prevent electric shock, wait for at least the time specified on the warning label; after all indicators are OFF, measure for unsafe voltages to confirm the drive is safe prior to servicing.

Table 7.2 Periodic Inspection Checklist

Inspection Area	Inspection Points	Corrective Action	Checked
Main Circuit Periodic Inspection			
General	<ul style="list-style-type: none"> Inspect equipment for discoloration from overheating or deterioration. Inspect for damaged or deformed parts. 	<ul style="list-style-type: none"> Replace damaged components as required. The drive has few serviceable parts and may require complete drive replacement. 	
	Inspect for dirt, foreign particles, or dust collection on components.	<ul style="list-style-type: none"> Inspect enclosure door seal if used. Use dry air to clear away foreign matter. Use a pressure of 39.2×10^4 to 58.8×10^4 Pa (4 - 6 kg•cm²) (57 to 85 psi). Replace components if cleaning is not possible. 	
Conductors and Wiring	<ul style="list-style-type: none"> Inspect wiring and connections for discoloration, damage, or heat stress. Inspect wire insulation and shielding for wear. 	Repair or replace damaged wiring.	
Terminals	Inspect terminals for stripped, damaged, or loose connections.	Tighten loose screws and replace damaged screws or terminals.	
Relays and Contactors	<ul style="list-style-type: none"> Inspect contactors and relays for excessive noise during operation. Inspect coils for signs of overheating such as melted or cracked insulation. 	<ul style="list-style-type: none"> Check coil voltage for overvoltage or undervoltage conditions. Replace damaged removable relays, contactors, or circuit board. 	
Braking Resistors	Inspect for discoloration of heat stress on or around resistors.	<ul style="list-style-type: none"> Minor discoloration may be acceptable. Check for loose connections if discoloration exists. 	
Electrolytic Capacitor	<ul style="list-style-type: none"> Inspect for leaking, discoloration, or cracks. Check if the cap has come off, for any swelling, or if the sides have burst open. 	The drive has few serviceable parts and may require complete drive replacement.	
Diode, IGBT (Power Transistor)	Inspect for dust or other foreign material collected on the surface.	Use dry air to clear away foreign matter. Use a pressure of 39.2×10^4 to 58.8×10^4 Pa (4 - 6 kg•cm ²) (57 to 85 psi).	
Motor Periodic Inspection			
Operation Check	Check for increased vibration or abnormal noise.	Stop the motor and contact qualified maintenance personnel as required.	
Control Circuit Periodic Inspection			
General	<ul style="list-style-type: none"> Inspect terminals for stripped, damaged, or loose connections. Make sure all terminals have been properly tightened. 	<ul style="list-style-type: none"> Tighten loose screws and replace damaged screws or terminals. If terminals are integral to a circuit board, then board or drive replacement may be required. 	
	Check for any odor, discoloration, and rust. Make sure connections are properly fastened and that no dust or oil mist has accumulated on the surface of the board.	<ul style="list-style-type: none"> Fix any loose connections. If an antistatic cloth or vacuum plunger cannot be used, replace the board. Do not use any solvents to clean the board. Use dry air to clear away foreign matter. Use a pressure of 39.2×10^4 to 58.8×10^4 Pa (4 - 6 kg•cm²) (57 to 85 psi). The drive has few serviceable parts and may require complete drive replacement.	

7.2 Inspection

Inspection Area	Inspection Points	Corrective Action	Checked
Cooling System Periodic Inspection			
Cooling Fan, Circulation Fan, Control Board Cooling Fan	<ul style="list-style-type: none"> • Check for abnormal oscillation or unusual noise. • Check for damaged or missing fan blades. 	<ul style="list-style-type: none"> • Replace as required. • <i>Refer to Drive Cooling Fans on page 405</i> for information on cleaning or replacing the fan. 	
Heatsink	Inspect for dust or other foreign material collected on the surface.	Use dry air to clear away foreign matter. Use a pressure of 39.2×10^4 to 58.8×10^4 Pa (4 - 6 kg•cm ²) (57 to 85 psi).	
Air Duct	Inspect air intake and exhaust openings. They must be free from obstruction and properly installed.	<ul style="list-style-type: none"> • Visually inspect the area. • Clear obstructions and clean air duct as required. 	
Display Periodic Inspection			
Digital Operator	<ul style="list-style-type: none"> • Make sure data appears on the display properly. • Inspect for dust or other foreign material that may have collected on surrounding components. 	<ul style="list-style-type: none"> • Contact the nearest sales office if there is any trouble with the display or keypad. • Clean the digital operator. 	

7.3 Periodic Maintenance

The drive has Maintenance Monitors that keep track of component wear. This feature provides advance maintenance warning and eliminates the need to shut down the entire system for unexpected problems. The drive allows the user to check predicted maintenance periods for the components listed below.

- Cooling Fan, Circulation Fan, Control Board Cooling Fan
- Electrolytic Capacitors
- Inrush Prevention Circuit
- IGBTs

For replacement parts, contact the distributor where the drive was purchased or contact Yaskawa directly.

◆ Replacement Parts

Table 7.3 contains the estimated performance life of components that require replacement during the life of the drive. Only use Yaskawa replacement parts for the appropriate drive model and revision.

Table 7.3 Estimated Performance Life

Component	Estimated Performance Life
Cooling Fan, Circulation Fan	10 years
Electrolytic Capacitors	10 years <1>

<1> The drive has few serviceable parts and may require complete drive replacement.

NOTICE: *Estimated performance life based on specific usage conditions. These conditions are provided for the purpose of replacing parts to maintain performance. Some parts may require more frequent replacement due to poor environments or rigorous use.*

Usage conditions for estimated performance life:

Ambient temperature: Yearly average of 40 °C (IP00/Open Type enclosure)

Load factor: 80% maximum

Operation time: 24 hours a day

■ Performance Life Monitors Maintenance Monitors

The drive calculates the maintenance period for components that may require replacement during the life of the drive. A percentage of the maintenance period is displayed on the digital operator by viewing the appropriate monitor parameter.

When the maintenance period reaches 100%, there is increased risk that the drive may malfunction. Yaskawa recommends checking the maintenance period regularly to ensure maximum performance life.

Refer to Recommended Periodic Inspection on page 401 for more details.

Table 7.4 Performance Life Monitors Used for Component Replacement

Parameter	Component	Contents
U4-03	Cooling Fan Circulation Fan	Displays the accumulated operation time of the fan from 0 to 99999 hours. This value is automatically reset to 0 after it reaches 99999.
U4-04	Control Board Cooling Fan	Displays the accumulated fan operation time as a percentage of the specified maintenance period.
U4-05	DC Bus Capacitors	Displays the accumulated time the capacitors are used as a percentage of the specified maintenance period.
U4-06	Inrush (pre-charge) Relay	Displays the number of times the drive is powered up as a percentage of the performance life of the inrush circuit.
U4-07	IGBT	Displays the percentage of the maintenance period reached by the IGBTs.

7.3 Periodic Maintenance

■ Alarm Outputs for Maintenance Monitors

An output can be set up to inform the user when a specific components has neared its expected performance life.

When one of multi-function digital output terminals has been assigned the maintenance monitor function (H2-□□ = 2F), the terminal will close when the cooling fan, DC bus capacitors, or DC bus pre-charge relay reach 90% of the expected performance life, or when the IGBTs have reached 50% of their expected performance life. Additionally the digital operator will display an alarm like shown in [Table 7.5](#) to indicate the specific components that may need maintenance.

Table 7.5 Maintenance Alarms

Digital Operator Alarm Display		Function	Corrective Action
LT-1 <1>	LT-1	The cooling fans have reached 90% of their designated life time.	Replace the cooling fan.
LT-2 <1>	LT-2	The DC bus capacitors have reached 90% of their designated life time.	Contact a Yaskawa representative or the nearest Yaskawa sales office on possible drive replacement.
LT-3 <1>	LT-3	The DC bus charge circuit has reached 90% of its designated life time.	Contact a Yaskawa representative or the nearest Yaskawa sales office on possible drive replacement.
LT-4 <1>	LT-4	The IGBTs have reached 50% of their designated life time.	Check the load, carrier frequency, and output frequency.
TrPC <2>	TrPC	The IGBTs have reached 90% of their designated life time.	Contact a Yaskawa representative or the nearest Yaskawa sales office on possible drive replacement.

<1> This alarm message will be output only if the Maintenance Monitor function is assigned to one of the digital outputs (H2-□□ = 2F). The alarm will also trigger a digital output that is programmed for alarm indication (H2-□□ = 10).

<2> This alarm message will always be output, even if the Maintenance Monitor function is not assigned to any of the digital outputs (H2-□□ = 2F). The alarm will also trigger a digital output that is programmed for alarm indication (H2-□□ = 10).

■ Related Drive Parameters

Use parameters o4-03, o4-05, o4-07, and o4-09 to reset a Maintenance Monitor to zero after replacing a specific component. [Refer to Parameter List on page 489](#) for details on parameter settings.

NOTICE: *If these parameters are not reset after the corresponding parts have been replaced, the Maintenance Monitor function will continue to count down the performance life from the value that was reached with the old part. If the Maintenance Monitor is not reset, the drive will not have the correct value of the performance life for the new component.*

7.4 Drive Cooling Fans

NOTICE: Follow cooling fan replacement instructions. The cooling fan cannot operate properly when installed incorrectly and could seriously damage the drive. To ensure maximum useful product life, replace all cooling fans when performing maintenance.

Contact a Yaskawa representative or the nearest Yaskawa sales office to order replacement cooling fans as required.

For drives with multiple cooling fans, replace all the fans when performing maintenance to ensure maximum product performance life.

◆ Number of Cooling Fans

Drive Model	Cooling Fans	Circulation Fans	Control Board Cooling Fans	Page
Three-Phase 200 V Class				
2A0004	–	–	–	–
2A0006	–	–	–	–
2A0008	–	–	–	–
2A0010	–	–	–	–
2A0012	–	–	–	–
2A0018	1	–	–	409
2A0021	1	–	–	
2A0030	2	–	–	
2A0040	2	–	–	
2A0056	2	–	–	
2A0069	2	–	–	
2A0081	2	–	–	
2A0110	2	–	–	411
2A0138	2	–	–	415
2A0169	2	–	–	
2A0211	2	–	–	
2A0250	2	–	–	
2A0312	2	–	–	
2A0360	3	1	–	
2A0415	3	1	–	
Three-Phase 400 V Class				
4A0002	–	–	–	–
4A0004	–	–	–	–
4A0005	–	–	–	–
4A0007	1	–	–	409
4A0009	1	–	–	
4A0011	1	–	–	
4A0018	2	–	–	
4A0023	2	–	–	
4A0031	2	–	–	
4A0038	2	–	–	
4A0044	2	–	–	411
4A0058	2	–	–	
4A0072	2	–	–	413
4A0088	2	–	–	
4A0103	2	–	–	

7.4 Drive Cooling Fans

Drive Model	Cooling Fans	Circulation Fans	Control Board Cooling Fans	Page
4A0139	2	–	–	415
4A0165	2	–	–	
4A0208	2	–	–	
4A0250	3	–	–	
4A0296	3	–	–	
4A0362	3	1	–	
4A0414	3	1	–	419
4A0515	3	2	2	421
4A0675	3	2	2	
4A0930	6	4	4	425
4A1200	6	4	4	
Three-Phase 600 V Class				
5A0003	–	–	–	–
5A0004	–	–	–	–
5A0006	1	–	–	409
5A0009	1	–	–	
5A0011	2	–	–	
5A0017	2	–	–	
5A0022	2	–	–	
5A0027	2	–	–	
5A0032	2	–	–	
5A0041	2	–	–	411
5A0052	2	–	–	
5A0062	2	–	–	415
5A0077	2	–	–	
5A0099	2	–	–	
5A0125	2	–	–	
5A0145	2	–	–	
5A0192	3	–	–	
5A0242	3	1	–	

◆ Cooling Fan Component Names

WARNING! Electrical Shock Hazard. Do not connect or disconnect wiring while the power is on. Failure to comply can result in serious personal injury. Before servicing the drive, disconnect all power to the equipment. The internal capacitor remains charged even after the power supply is turned off. After shutting off the power, wait for at least the amount of time specified on the drive before touching any components.

CAUTION! Burn Hazard. Do not touch a hot drive heatsink. Failure to comply could result in minor or moderate injury. Shut off the power to the drive when replacing the cooling fan. To prevent burns, wait at least 15 minutes and ensure the heatsink has cooled down.

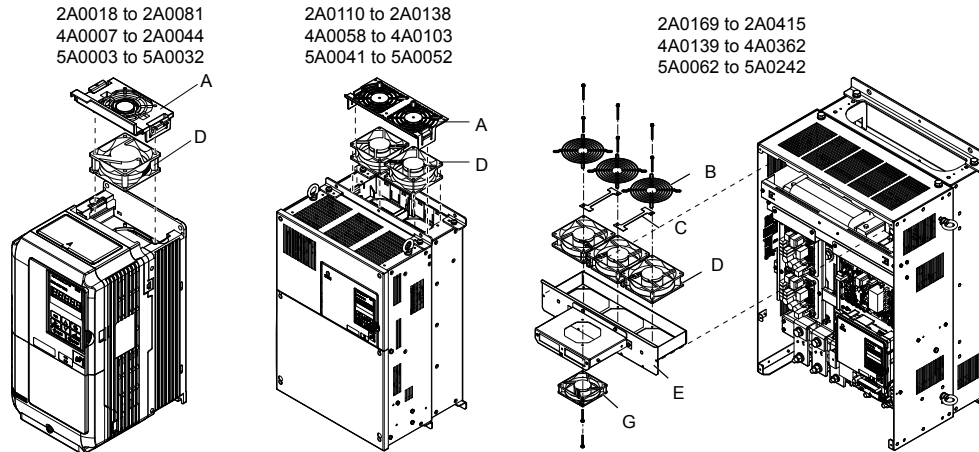

Figure 7.1 Cooling Fan Component Names

Remaining models can be found on the following page.

7.4 Drive Cooling Fans

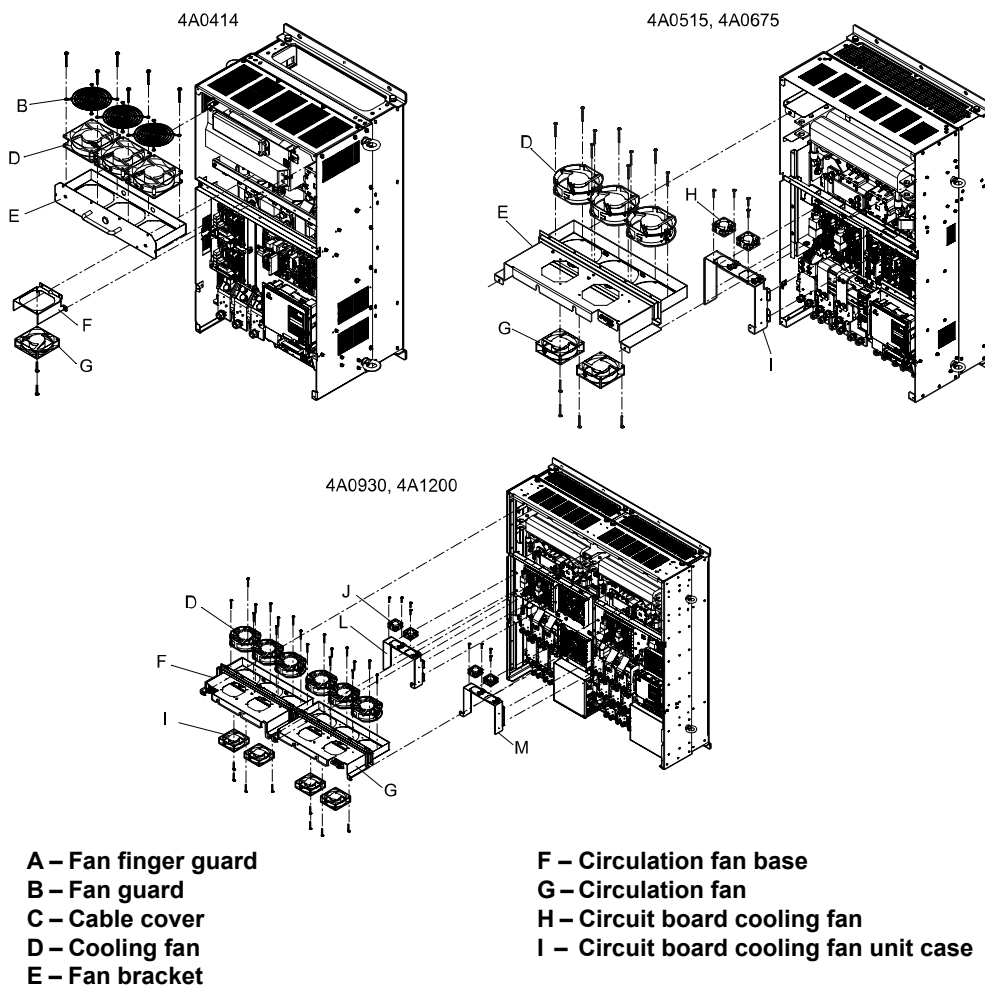

Figure 7.2 Cooling Fan Component Names (Continued)

◆ Cooling Fan Replacement: 2A0018 to 2A0081, 4A0007 to 4A0044, and 5A0006 to 5A0032

WARNING! *Electrical Shock Hazard. Do not connect or disconnect wiring while the power is on. Failure to comply can result in serious personal injury. Before servicing the drive, disconnect all power to the equipment. The internal capacitor remains charged even after the power supply is turned off. After shutting off the power, wait for at least the amount of time specified on the drive before touching any components.*

CAUTION! *Burn Hazard. Do not touch a hot drive heatsink. Failure to comply could result in minor or moderate injury. Shut off the power to the drive when replacing the cooling fan. To prevent burns, wait at least 15 minutes and ensure the heatsink has cooled down.*

NOTICE: *Follow cooling fan replacement instructions. Improper fan replacement could cause damage to equipment. Make sure the fan is facing upwards when installing the replacement fan into the drive. Replace all fans when performing maintenance to help ensure maximum useful product life.*

■ Removing the Cooling Fan Finger Guard and Cooling Fan

1. Depress the right and left sides of the fan cover tabs and pull upward. Remove the fan cover from the top of the drive. The following figure illustrates a drive with a single cooling fan.

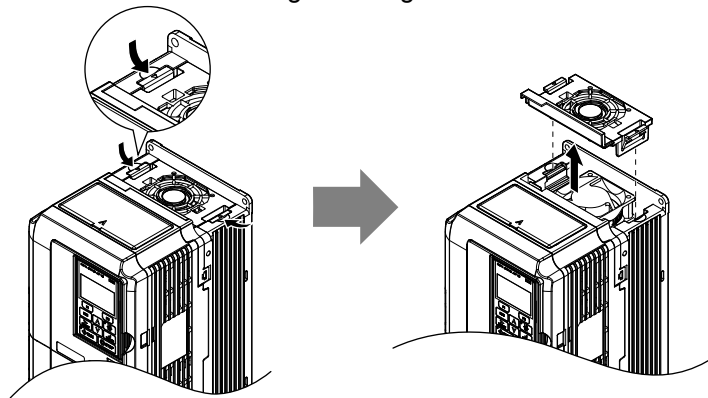

Figure 7.3 Remove the Cooling Fan Finger Guard: 2A0018 to 2A0081, 4A0007 to 4A0044, and 5A0006 to 5A0032

2. Remove the cooling fan cartridge. Disconnect the pluggable connector and remove the fan.

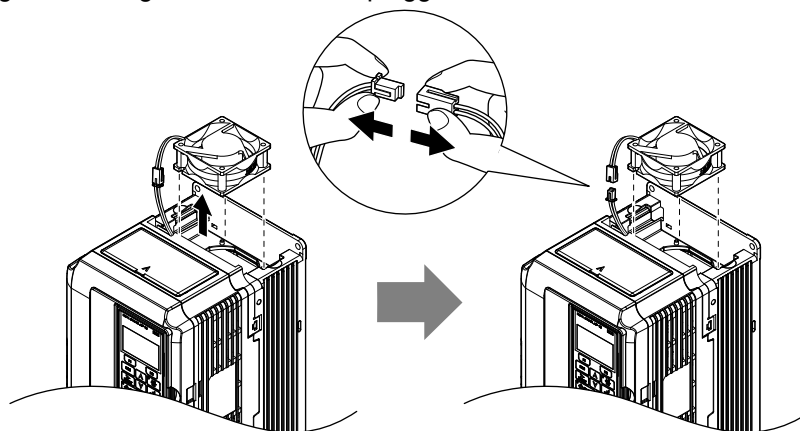

Figure 7.4 Remove the Cooling Fan: 2A0018 to 2A0081, 4A0007 to 4A0044, and 5A0006 to 5A0032

■ Installing the Cooling Fan

NOTICE: Prevent Equipment Damage. Follow cooling fan replacement instructions. Improper cooling fan replacement could result in damage to equipment. When installing the replacement cooling fan into the drive, make sure the fan is facing upwards. To ensure maximum useful product life, replace all cooling fans when performing maintenance.

Reverse the procedure described above to reinstall the cooling fan.

1. Install the replacement cooling fan into the drive, ensuring the alignment pins line up as shown in the figure below.

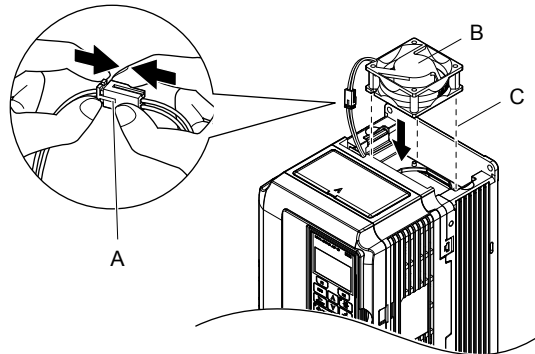

A – Push the connectors together so no space remains between them
B – Label facing up

C – Make sure the alignment pins line up properly

Figure 7.5 Install the Cooling Fan: 2A0018 to 2A0081, 4A0007 to 4A0044, and 5A0006 to 5A0032

2. Properly connect the fan power lines, then place the cable back into the recess of the drive.

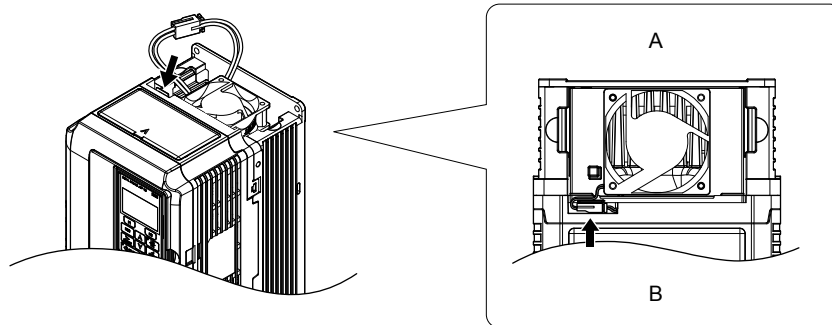

A – Back

B – Front

Figure 7.6 Connect the Cooling Fan Power Supply Connectors: 2A0018 to 2A0081, 4A0007 to 4A0044, and 5A0006 to 5A0032

3. While pressing in on the hooks on the left and right sides of the fan finger guard, guide the fan finger guard until it clicks back into place.

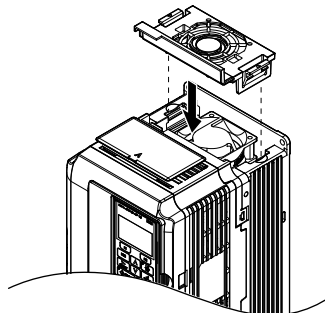

Figure 7.7 Reattach the Fan Finger Guard: 2A0018 to 2A0081, 4A0007 to 4A0044, and 5A0006 to 5A0032

4. Turn on the power supply and set o4-03 to 0 to reset the Maintenance Monitor cooling fan operation time.

◆ Cooling Fan Replacement: 2A0110, 2A0138, 4A0058, 4A0072, 5A0041, and 5A0052

WARNING! *Electrical Shock Hazard. Do not connect or disconnect wiring while the power is on. Failure to comply can result in serious personal injury. Before servicing the drive, disconnect all power to the equipment. The internal capacitor remains charged even after the power supply is turned off. After shutting off the power, wait for at least the amount of time specified on the drive before touching any components.*

CAUTION! *Burn Hazard. Do not touch a hot drive heatsink. Failure to comply could result in minor or moderate injury. Shut off the power to the drive when replacing the cooling fan. To prevent burns, wait at least 15 minutes and ensure the heatsink has cooled down.*

NOTICE: *Follow cooling fan and circulation fan replacement instructions. Improper fan replacement may cause damage to equipment. When installing the replacement fan into the drive, make sure the fan is facing upwards. Replace all fans when performing maintenance to help ensure maximum useful product life.*

■ Removing the Cooling Fan Finger Guard and Cooling Fan

1. While pressing in on the hooks located on the left and right sides of the fan finger guard, free the fan finger guard leading by lifting the back end first.

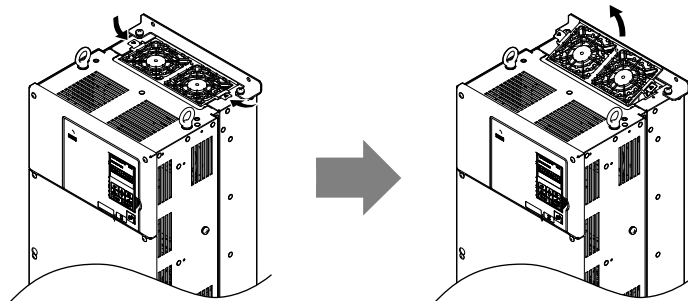

Figure 7.8 Remove the Cooling Fan Finger Guard: 2A0110, 2A0138, 4A0058, 4A0072, 5A0041, and 5A0052

2. Lift out the back end of the fan finger guard first. Unplug the replay connector and free the fan finger guard from the drive.

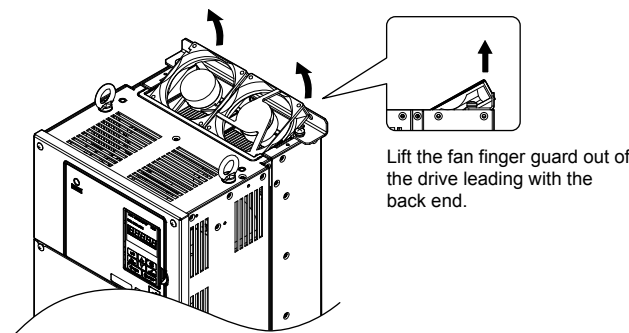

Figure 7.9 Remove the Cooling Fan: 2A0110, 2A0138, 4A0058, 4A0072, 5A0041, and 5A0052

■ Installing the Cooling Fan

Reverse the procedure described above to reinstall the cooling fan.

1. Properly connect the fan power lines.
2. Place the power supply connectors and cable back into the recess of the drive.

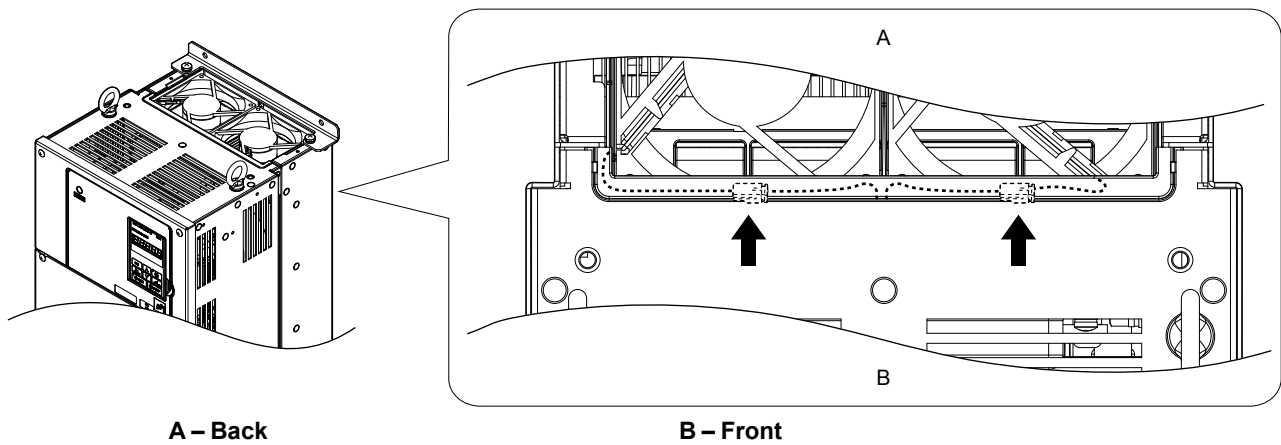

Figure 7.10 Cooling Fan Power Supply Connectors: 2A0110, 2A0138, 4A0058, 4A0072, 5A0041, and 5A0052

3. Install the replacement fan into the drive.

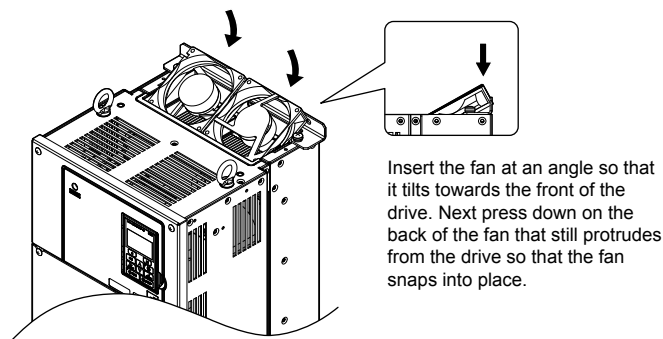

Figure 7.11 Install the Cooling Fan: 2A0110, 2A0138, 4A0058, 4A0072, 5A0041, and 5A0052

4. Tilt up the back end of the fan finger guard and slide the fan finger guard into the opening near the front of the drive, then guide the fan finger guard into place.

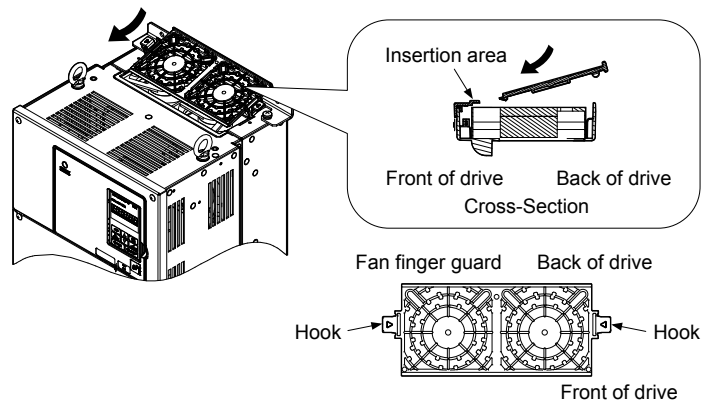

Figure 7.12 Reattach the Fan Cover: 2A0110, 2A0138, 4A0058, 4A0072, 5A0041, and 5A0052

5. Press in on the hooks of the left and right sides of the fan cover and guide the fan finger guard until it clicks into place.

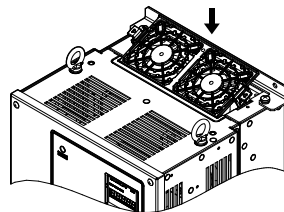

Figure 7.13 Reattach the Fan Finger Guard: 2A0110, 2A0138, 4A0058, 4A0072, 5A0041, and 5A0052

6. Turn on the power supply and set o4-03 to 0 to reset the Maintenance Monitor cooling fan operation time.

◆ Cooling Fan Replacement: 4A0088 and 4A0103

WARNING! *Electrical Shock Hazard. Do not connect or disconnect wiring while the power is on. Failure to comply can result in serious personal injury. Before servicing the drive, disconnect all power to the equipment. The internal capacitor remains charged even after the power supply is turned off. After shutting off the power, wait for at least the amount of time specified on the drive before touching any components.*

CAUTION! *Burn Hazard. Do not touch a hot drive heatsink. Failure to comply could result in minor or moderate injury. Shut off the power to the drive when replacing the cooling fan. To prevent burns, wait at least 15 minutes and ensure the heatsink has cooled down.*

NOTICE: *Follow cooling fan and circulation fan replacement instructions. Improper fan replacement may cause damage to equipment. When installing the replacement fan into the drive, make sure the fan is facing upwards. Replace all fans when performing maintenance to help ensure maximum useful product life.*

■ Removing the Cooling Fan Finger Guard and Cooling Fan

1. While pressing in on the hooks located on the left and right sides of the fan finger guard, free the fan finger guard by lifting the back end first.

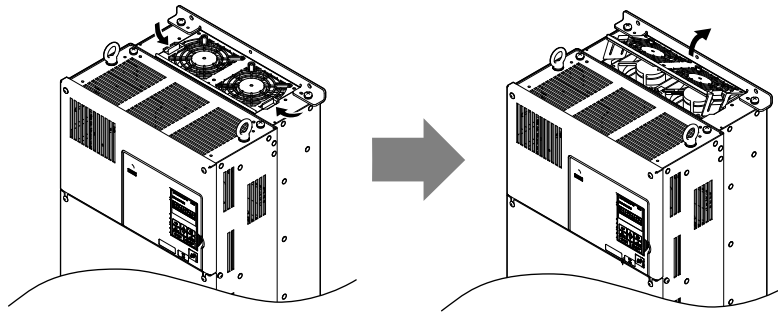

Figure 7.14 Remove the Cooling Fan Finger Guard: 4A0088 and 4A0103

2. Lift up directly on the cooling fan as shown in [Figure 7.15](#). Unplug the relay connector and release the fan from the drive.

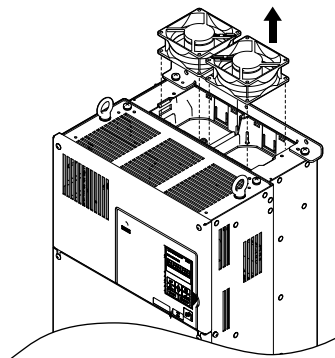

Figure 7.15 Remove the Cooling Fan: 4A0088 and 4A0103

■ Installing the Cooling Fan

Reverse the procedure describe above to reinstall the cooling fan.

1. Install the replacement fan into the drive. Align the pins as shown in [Figure 7.16](#).

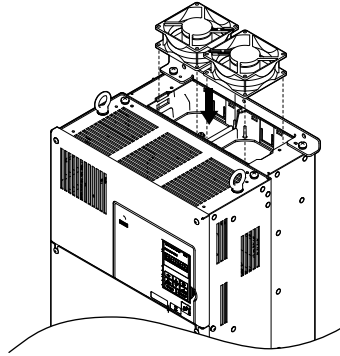
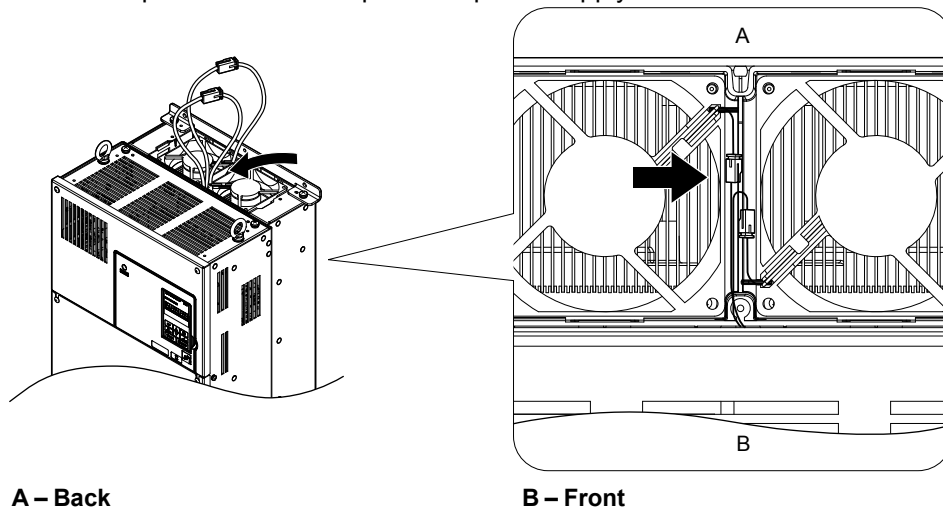

Figure 7.16 Install the Cooling Fan: 4A0088 and 4A0103

2. Properly connect the fan power lines then replace the power supply connectors and cables into the recess of the drive.



A – Back

B – Front

Figure 7.17 Cooling Fan Power Supply Connectors: 4A0088 and 4A0103

3. Angle the fan finger guard as shown in [Figure 7.18](#) and insert the connector tabs into the corresponding holes on the drive.

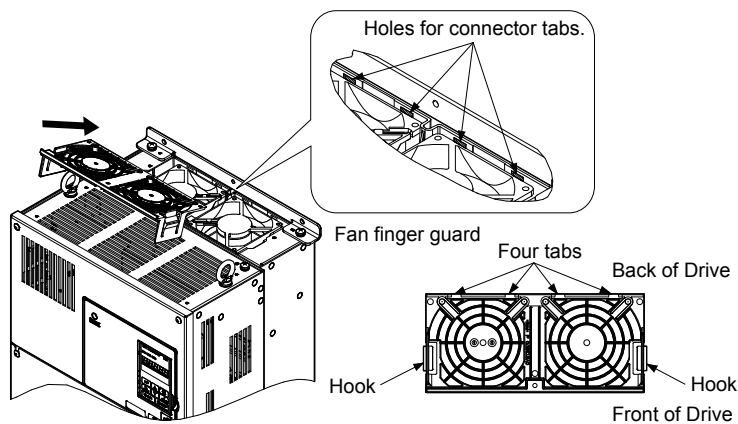

Figure 7.18 Reattach the Fan Finger Guard: 4A0088 and 4A0103

4. While pressing in on the hooks of the left and right sides of the fan finger guard, guide the fan finger guard until it clicks back into place.

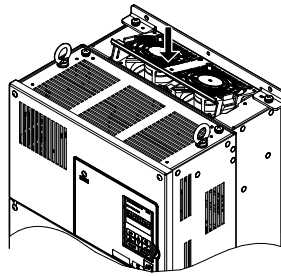

Figure 7.19 Reattach the Fan Finger Guard: 4A0088 and 4A0103

- Turn on the power supply and set o4-03 to 0 to reset the Maintenance Monitor cooling fan operation time.

◆ Cooling Fan Replacement: 2A0169 to 2A0415, 4A0139 to 4A0362, and 5A0062 to 5A0242

WARNING! *Electrical Shock Hazard. Do not connect or disconnect wiring while the power is on. Failure to comply can result in serious personal injury. Before servicing the drive, disconnect all power to the equipment. The internal capacitor remains charged even after the power supply is turned off. After shutting off the power, wait for at least the amount of time specified on the drive before touching any components.*

CAUTION! *Burn Hazard. Do not touch a hot drive heatsink. Failure to comply could result in minor or moderate injury. Shut off the power to the drive when replacing the cooling fan. To prevent burns, wait at least 15 minutes and ensure the heatsink has cooled down.*

NOTICE: *Follow cooling fan and circulation fan replacement instructions. Improper fan replacement may cause damage to equipment. When installing the replacement fan into the drive, make sure the fan is facing upwards. Replace all fans when performing maintenance to help ensure maximum useful product life.*

■ Removing and Disassembling the Cooling Fan Unit

- Remove the terminal cover and front cover.
- Remove the fan connector (CN6).

Remove the fan connectors (CN6, CN7) in models 2A0360, 2A0415, 4A0362, and 5A0242.

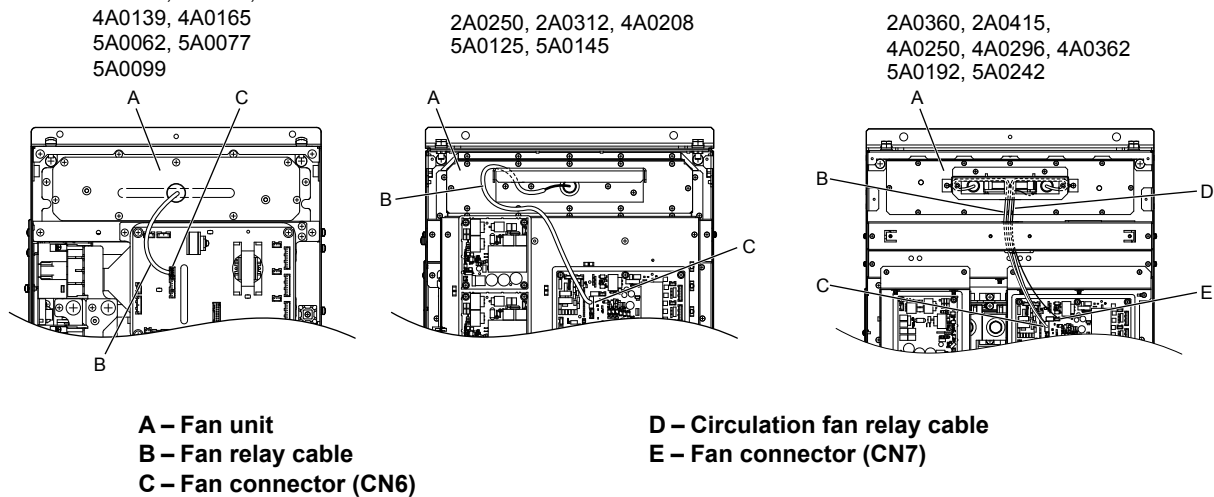

Figure 7.20 Cooling Fan Replacement: Fan Unit and Connectors

- Remove the screws holding the fan unit in place and slide the fan unit out of the drive.

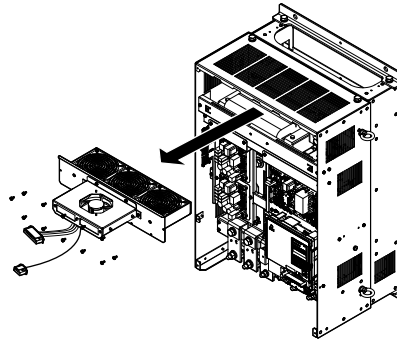

Figure 7.21 Remove the Fan Unit: 2A0169 to 2A0415, 4A0139 to 4A0362, and 5A0062 to 5A0242

4. Remove the fan guard and replace the cooling fans.

Note: Do not pinch the fan cable between parts when reassembling the fan unit.

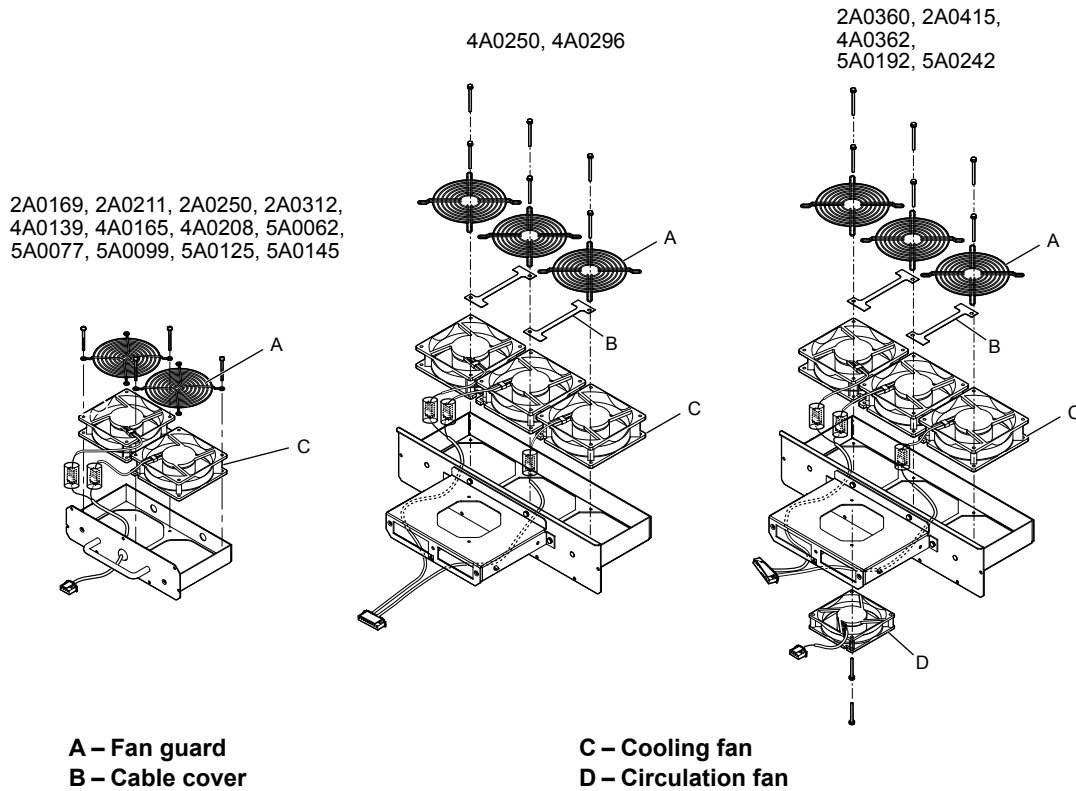
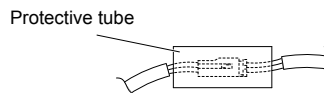

Figure 7.22 Fan Unit Disassembly: 2A0169 to 2A0415, 4A0139 to 4A0362, and 5A0062 to 5A0242

■ Cooling Fan Wiring: 2A0169, 2A0211, 4A0139, 4A0165, and 5A0062 to 5A0099

1. Position the protective tube so the fan connector sits in the center of the protective tube.



2. Place the fan connector covered by the tube as shown in [Figure 7.23](#).

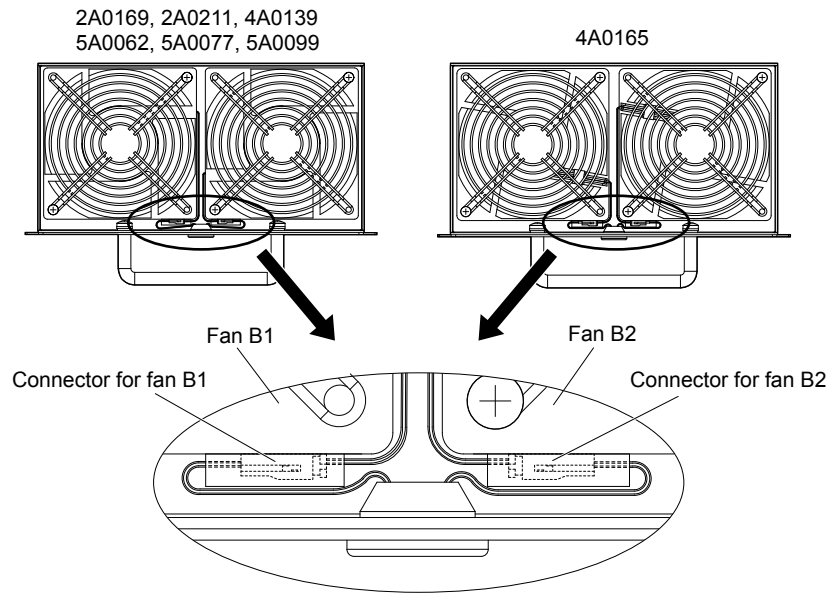
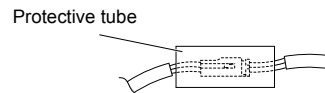

Figure 7.23 Cooling Fan Wiring: 2A0169, 2A0211, 4A0139, 4A0165, and 5A0062 to 5A0099

3. Make sure that the protective tube does not stick out beyond the fan guard.

■ Cooling Fan Wiring: 2A0250, 2A0312, 4A0208, 5A0125, and 5A0145

1. Position the protective tube so the fan connector sits in the center of the protective tube.



2. Insert the connector for fan B2 and guide the lead wire for fan B2 so the cable hook holds it in place. Insert the connector for fan B1.

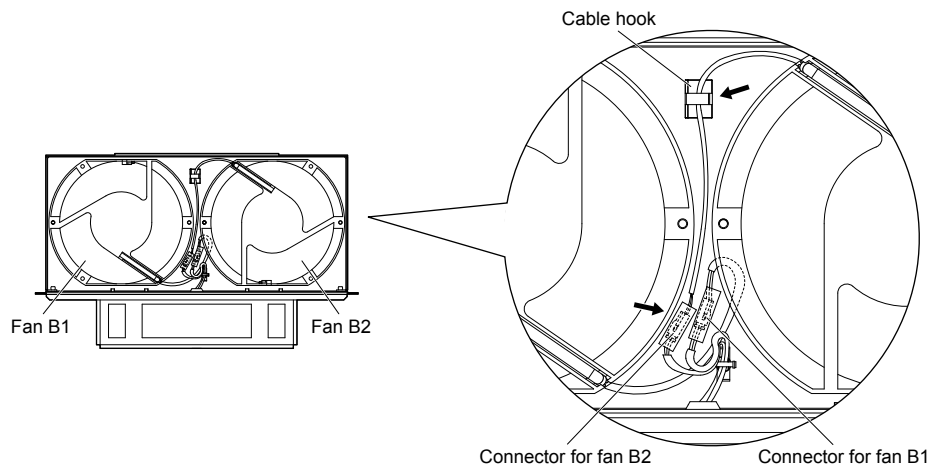
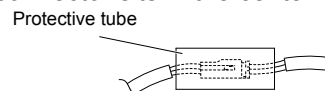

Figure 7.24 Cooling Fan Wiring: 2A0250, 2A0312, 4A0208, 5A0125, and 5A0145

3. Make sure that the protective tube does not stick out beyond the fan guard.

■ Cooling Fan Wiring: 2A0360, 2A0415, 4A0250 to 4A0362, 5A0192, and 5A0242

1. Position the protective tube so the fan connector sits in the center of the protective tube.



2. In the space between fans 1 and 2, place the fan connector for fan B2 in front of the fan connector for fan B1.
3. Place the connector for fan B3 between fans B2 and B3.

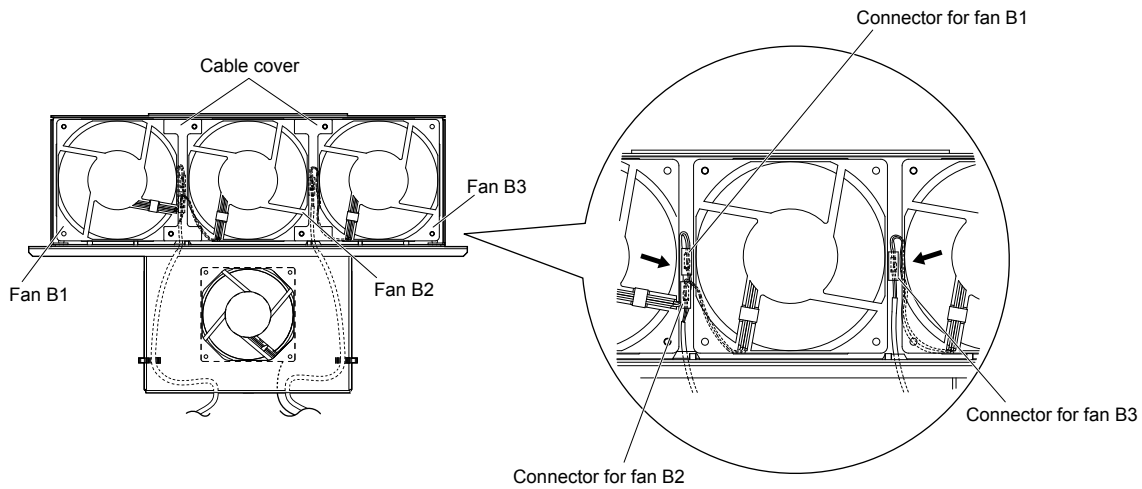

Figure 7.25 Cooling Fan Wiring: 2A0360, 2A0415, 4A0250 to 4A0362, 5A0192, and 5A0242

4. Double-check the relay connector to ensure it is properly connected.
5. Reattach the cable cover to its original position and tighten the screws so the fan guard holds the cable cover in place.

Note: Do not pinch the fan cable between parts when reassembling the fan unit.

■ Installing the Cooling Fan Unit

1. Reverse the procedure described above to reinstall the cooling fan unit.

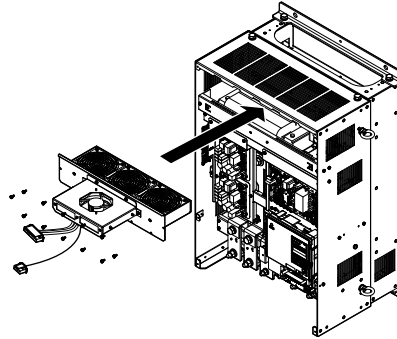

Figure 7.26 Install the Cooling Fan Unit: 2A0169 to 2A0415 and 4A0139 to 4A0362, and 5A0062 to 5A0242

2. Reattach the covers and digital operator.
3. Turn on the power supply and set o4-03 to 0 to reset the Maintenance Monitor cooling fan operation time.

◆ Cooling Fan Replacement: 4A0414

WARNING! *Electrical Shock Hazard. Do not connect or disconnect wiring while the power is on. Failure to comply can result in serious personal injury. Before servicing the drive, disconnect all power to the equipment. The internal capacitor remains charged even after the power supply is turned off. After shutting off the power, wait for at least the amount of time specified on the drive before touching any components.*

CAUTION! *Burn Hazard. Do not touch a hot drive heatsink. Failure to comply could result in minor or moderate injury. Shut off the power to the drive when replacing the cooling fan. To prevent burns, wait at least 15 minutes and ensure the heatsink has cooled down.*

NOTICE: *Follow cooling fan and circulation fan replacement instructions. Improper fan replacement may cause damage to equipment. When installing the replacement fan into the drive, make sure the fan is facing upwards. Replace all fans when performing maintenance to help ensure maximum useful product life.*

■ Removing and Disassembling the Cooling Fan Unit

1. Remove the terminal cover and front covers 1 and 2.
2. Remove the fan connector (CN6).

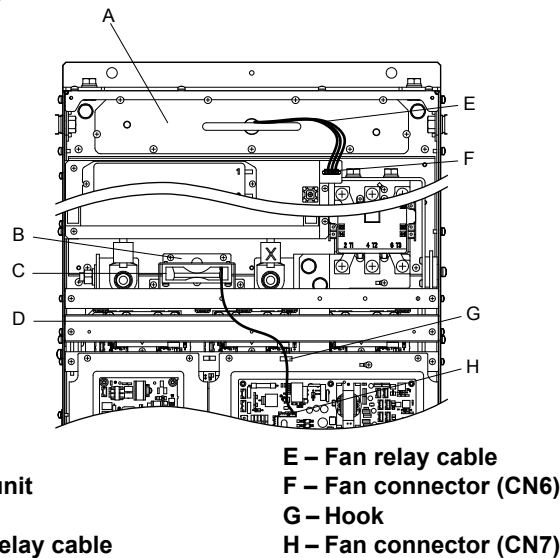

Figure 7.27 Component Names: 4A0414

3. Remove the circulation fan relay cable from the hook. Remove the fan connector (CN7).
4. Remove the screws holding the fan units in place and slide the fan units out of the drive.

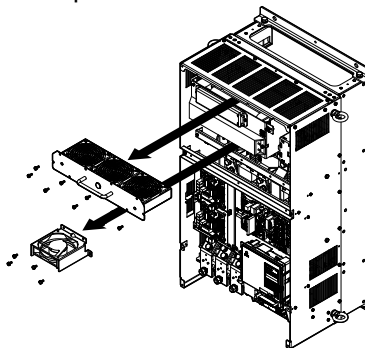

Figure 7.28 Remove the Fan Unit: 4A0414

5. Remove the fan guard and circulation fan casing. Replace the cooling fans.

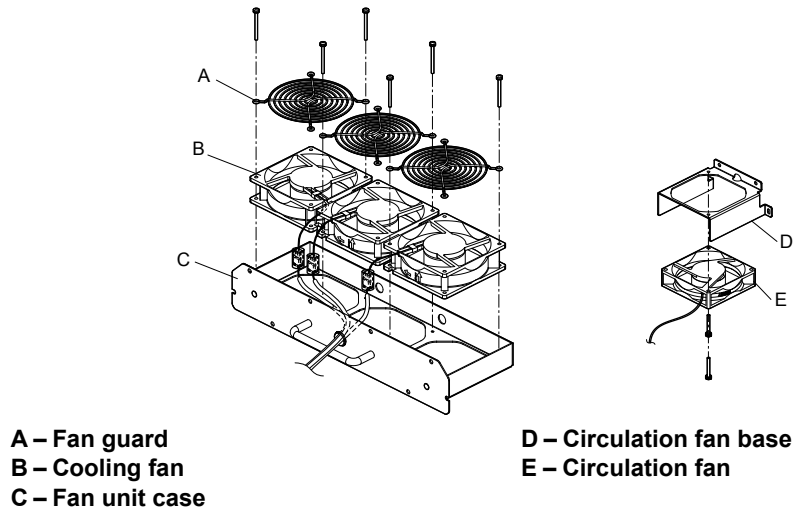
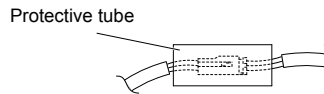

Figure 7.29 Fan Unit Disassembly: 4A0414

■ Cooling Fan Wiring

1. Position the protective tube so the fan connector sits in the center of the protective tube.



2. Place the fan connector covered by the tube as shown in [Figure 7.30](#).

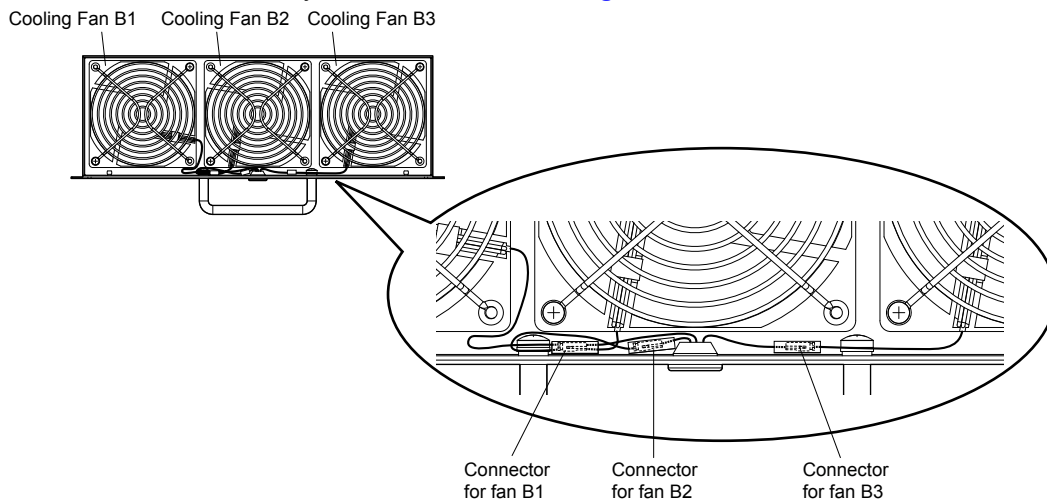

Figure 7.30 Cooling Fan Wiring: 4A0414

3. Double-check the relay connector to ensure that it is properly connected.

■ Installing the Cooling Fan Unit

1. Reverse the procedure described above to reinstall the cooling fan unit.

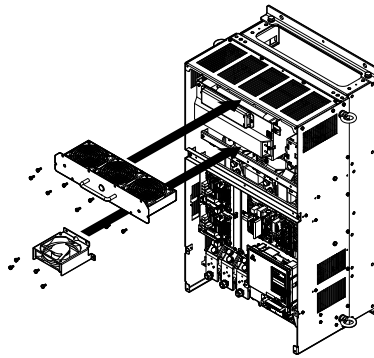

Figure 7.31 Install the Cooling Fan Unit: 4A0414

2. Reattach the covers and digital operator.
3. Turn on the power supply and set o4-03 to 0 to reset the Maintenance Monitor cooling fan operation time.

◆ Cooling Fan Replacement: 4A0515 and 4A0675

WARNING! *Electrical Shock Hazard. Do not connect or disconnect wiring while the power is on. Failure to comply can result in serious personal injury. Before servicing the drive, disconnect all power to the equipment. The internal capacitor remains charged even after the power supply is turned off. After shutting off the power, wait for at least the amount of time specified on the drive before touching any components.*

CAUTION! *Burn Hazard. Do not touch a hot drive heatsink. Failure to comply could result in minor or moderate injury. Shut off the power to the drive when replacing the cooling fan. To prevent burns, wait at least 15 minutes and ensure the heatsink has cooled down.*

NOTICE: *Follow cooling fan and circulation fan replacement instructions. Improper fan replacement may cause damage to equipment. When installing the replacement fan into the drive, make sure the fan is facing upwards. Replace all fans when performing maintenance to help ensure maximum useful product life.*

■ Removing and Disassembling the Cooling Fan Unit

1. Remove the terminal cover and front covers 1 and 2.
2. Remove the connectors for the cooling fan relay and the circuit board cooling fan.

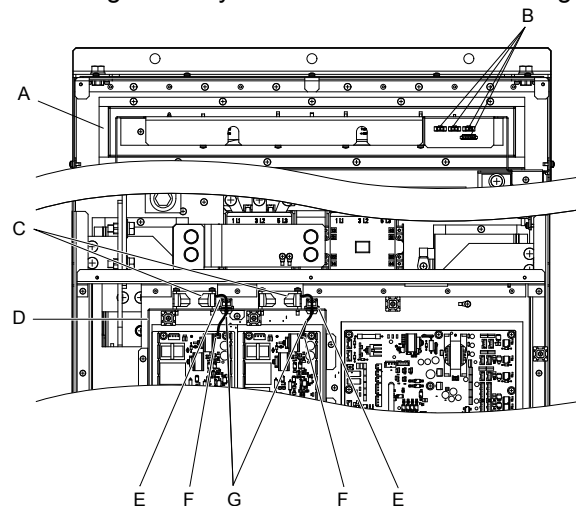

- | | |
|------------------------------------|---|
| A – Fan unit | E – Hook |
| B – Fan relay connector | F – Circuit board cooling fan connector |
| C – Circuit board cooling fan | G – Circuit board cooling fan cable |
| D – Circuit board cooling fan case | |

Figure 7.32 Component Names: 4A0515 and 4A0675

3. Loosen all nine screws and slide the panel to the right.

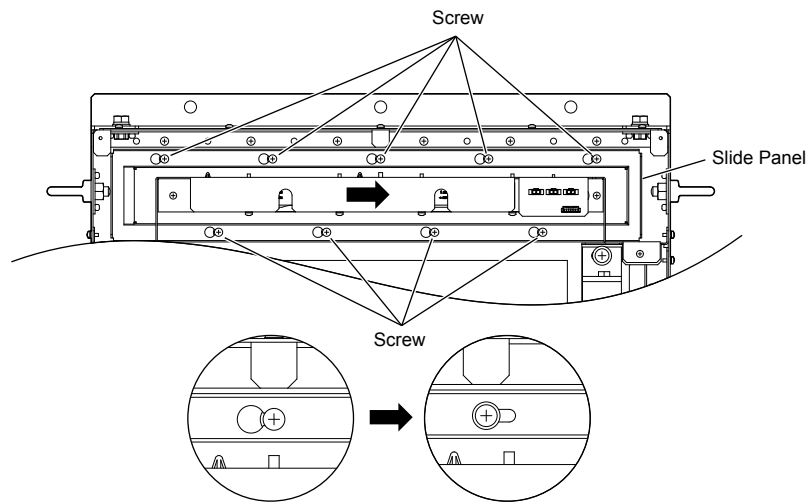

Figure 7.33 Remove the Fan Unit: 4A0515 and 4A0675

4. Remove the slide panel, fan unit, and circuit board cooling fan unit.

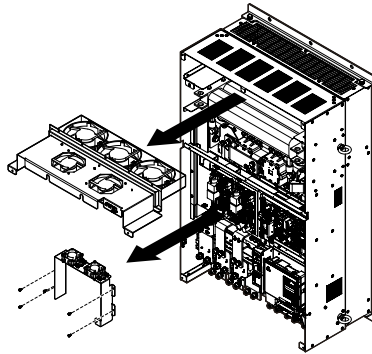
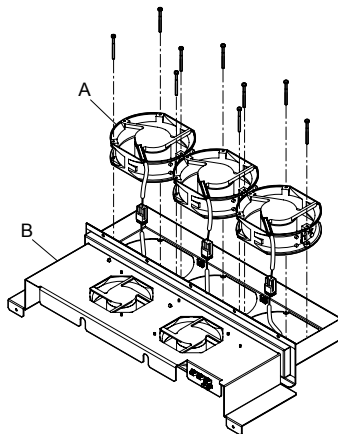

Figure 7.34 Remove the Fan Unit: 4A0515 and 4A0675

5. Replace the cooling fans.

Note: Do not pinch the fan cable between parts when reassembling the fan unit.



A – Cooling fan

B – Fan unit case

Figure 7.35 Fan Unit Disassembly: 4A0515 and 4A0675

6. Turn the fan unit over and replace the circulation fans.

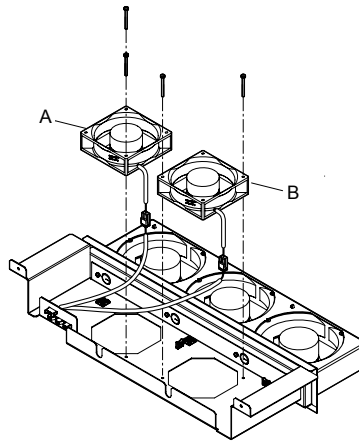

A – Circulation fan 1

B – Circulation fan 2

Figure 7.36 Fan Unit Disassembly: 4A0515 and 4A0675

7. Replace the cooling fans.

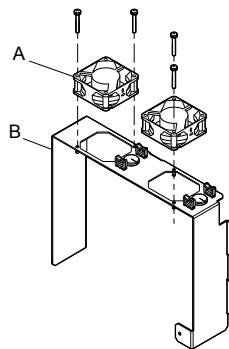

A – Circuit board cooling fan

B – Circuit board cooling fan case

Figure 7.37 Fan Unit Disassembly: 4A0515 and 4A0675

■ Cooling Fan Wiring

1. Place the cooling fan connectors and guide the lead wires so they are held in place by the cable hooks.

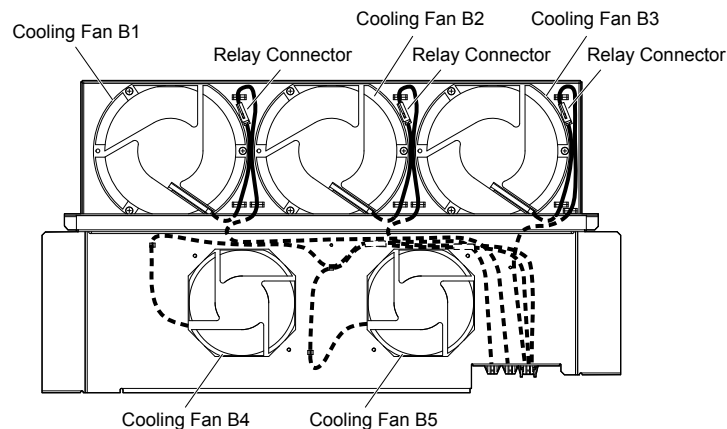

Figure 7.38 Cooling Fan Wiring: 4A0515 and 4A0675

2. Guide the lead wires so that they are held in place by the cable hooks and place the circulation fan connectors between the fan and the fan unit.

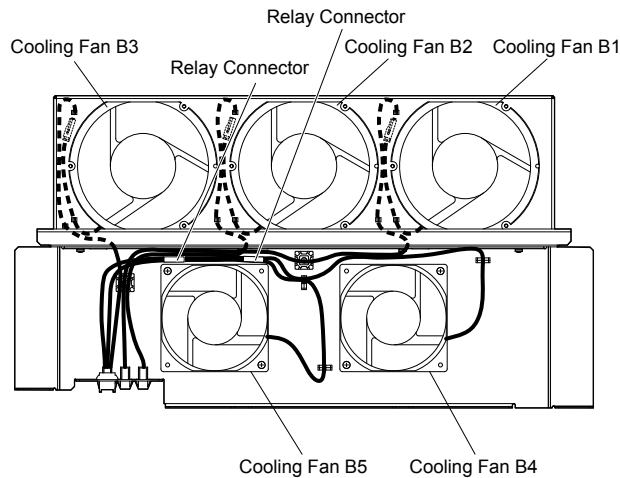
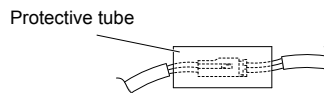

Figure 7.39 Cooling Fan Wiring: 4A0515 and 4A0675

3. Position the protective tube so the fan connector sits in the center of the protective tube. (Circuit board cooling fans only)



4. Guide the lead wires through the provided hooks so the wires are held in place.

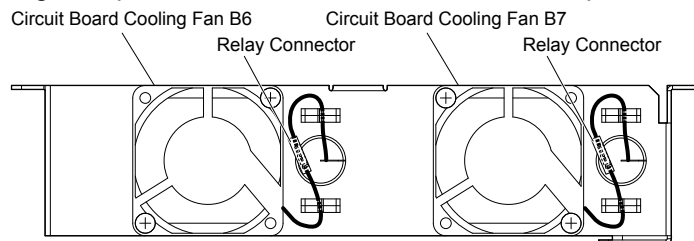

Figure 7.40 Cooling Fan Wiring: 4A0515 and 4A0675

5. Double-check the relay connector to ensure that it is properly connected.

■ Installing the Cooling Fan Unit

1. Reverse the procedure described above to reinstall the cooling fan unit.

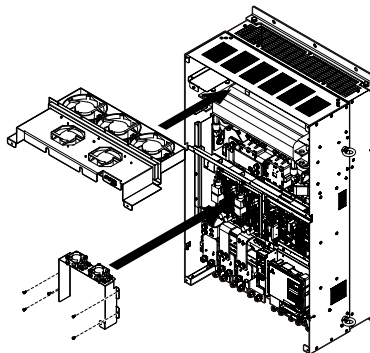

Figure 7.41 Install the Cooling Fan Unit: 4A0515 and 4A0675

2. Reattach the covers and digital operator.
3. Turn on the power supply and set o4-03 to 0 to reset the Maintenance Monitor cooling fan operation time.

◆ Cooling Fan Replacement: 4A0930 and 4A1200

WARNING! *Electrical Shock Hazard. Do not connect or disconnect wiring while the power is on. Failure to comply can result in serious personal injury. Before servicing the drive, disconnect all power to the equipment. The internal capacitor remains charged even after the power supply is turned off. After shutting off the power, wait for at least the amount of time specified on the drive before touching any components.*

CAUTION! *Burn Hazard. Do not touch a hot drive heatsink. Failure to comply could result in minor or moderate injury. Shut off the power to the drive when replacing the cooling fan. To prevent burns, wait at least 15 minutes and ensure the heatsink has cooled down.*

NOTICE: *Follow cooling fan and circulation fan replacement instructions. Improper fan replacement may cause damage to equipment. When installing the replacement fan into the drive, make sure the fan is facing upwards. Replace all fans when performing maintenance to help ensure maximum useful product life.*

■ Removing and Disassembling the Cooling Fan Unit

1. Remove the terminal cover and front covers 1 and 2.

CAUTION! *Crush Hazard. Do not completely remove the cover screws, just loosen them. If the cover screws are removed completely, the terminal cover may fall off and cause an injury. Take special care when removing and reattaching the terminal covers for larger drives.*

2. Remove the connectors for the cooling fan relay and the circuit board cooling fan.

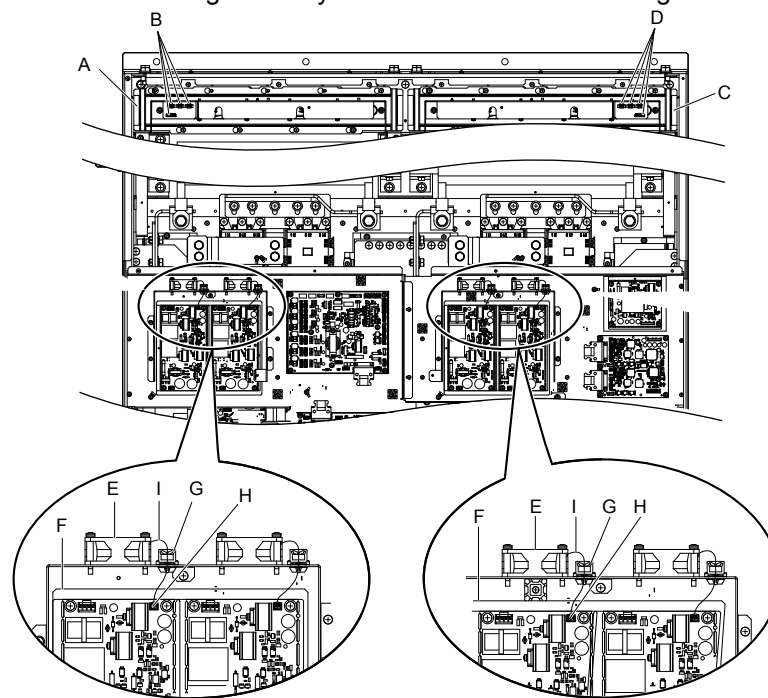

- | | |
|-------------------------------|---|
| A – Fan unit (L) | F – Circuit board cooling fan case |
| B – Fan relay connector (L) | G – Hook |
| C – Fan unit (R) | H – Circuit board cooling fan connector |
| D – Fan relay connector (R) | I – Circuit board cooling fan cable |
| E – Circuit board cooling fan | |

Figure 7.42 Component Names: 4A0930 and 4A1200

3. Loosen screws A (4 count) and B (18 count) and slide the panel to the right.

Note: The fan unit can be removed by loosening these screws; they do not need to be removed.

7.4 Drive Cooling Fans

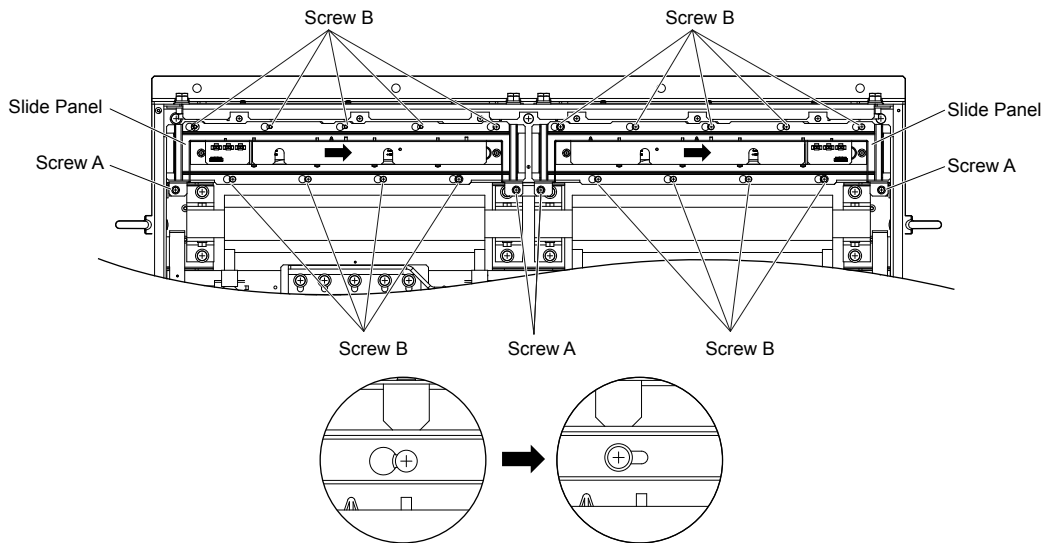

Figure 7.43 Remove the Fan Unit: 4A0930 and 4A1200

4. Remove the slide panel, fan units, and circuit board cooling fan unit.

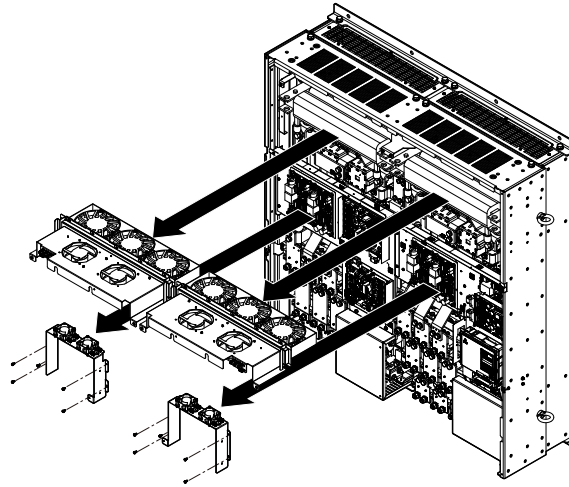
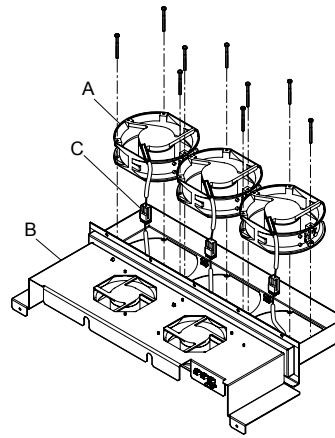

Figure 7.44 Remove the Fan Unit: 4A0930 and 4A1200

5. Replace the cooling fans.

- Note:**
1. [Figure 7.45](#) shows the right side fan unit.
 2. Do not pinch the fan cable between parts when reassembling the fan unit.



A – Cooling fan
B – Fan unit case

C – Cooling fan connector

Figure 7.45 Fan Unit Disassembly: 4A0930 and 4A1200

6. Place the cooling fan connectors and guide the lead wires so that they are held in place by the cable hooks.

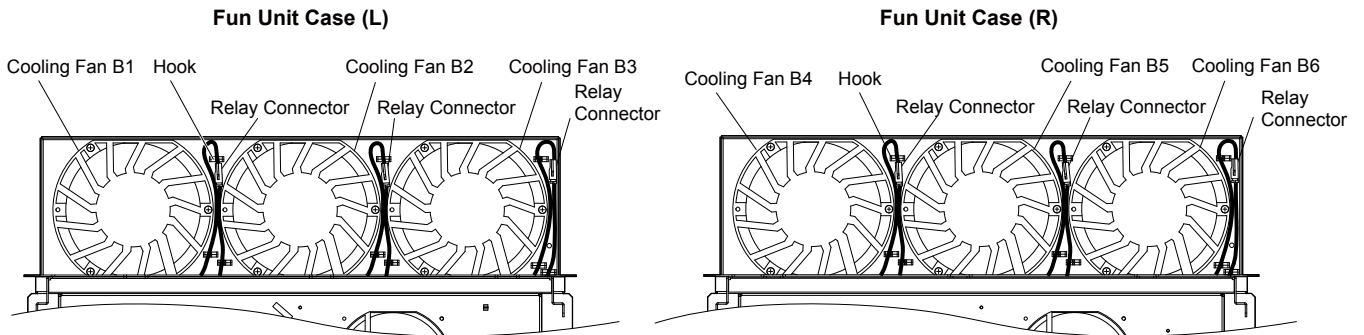
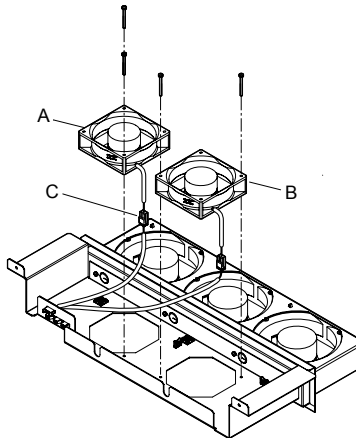

Figure 7.46 Cooling Fan Wiring: 4A0930 and 4A1200

7. Turn the fan unit over and replace the circulation fans.



A – Circulation fan 1
B – Circulation fan 2

C – Cooling fan connector

Figure 7.47 Fan Unit Disassembly: 4A0930 and 4A1200

8. Place the cooling fan connectors and guide the lead wires so that they are held in place by the cable hooks.

7.4 Drive Cooling Fans

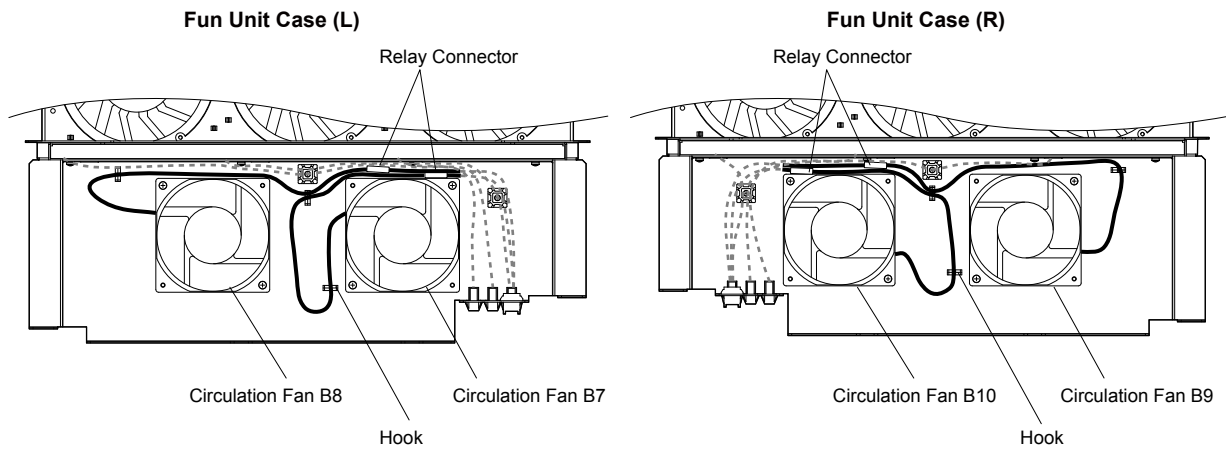
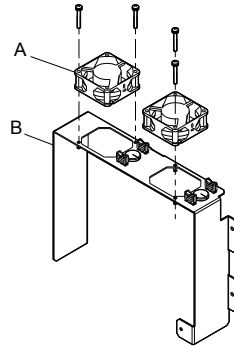

Figure 7.48 Cooling Fan Wiring: 4A0930 and 4A1200

9. Replace the circuit board cooling fans.

Note: [Figure 7.49](#) shows the right side circuit board cooling fan.



A – Circuit board cooling fan

B – Circuit board cooling fan case

Figure 7.49 Fan Unit Disassembly: 4A0930 and 4A1200

10. Position the protective tube so the fan connector sits in the center of the protective tube. (Circuit board cooling fans only)

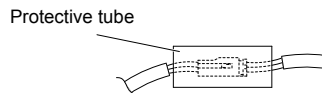

11. Guide the lead wires through the provided hooks so the wires are held in place.

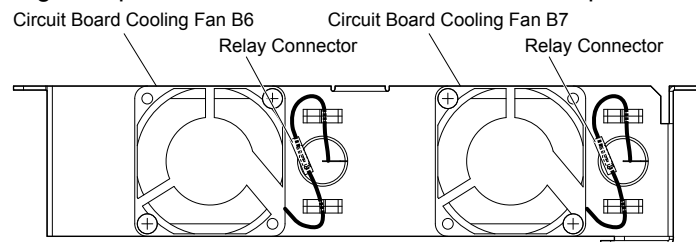

Figure 7.50 Cooling Fan Wiring: 4A0930 and 4A1200

12. Double-check the relay connector to ensure that it is properly connected.

■ Installing the Cooling Fan Unit

1. Reverse the procedure described above to reinstall the cooling fan unit.

Note: Properly connect the relay connectors to the fan unit connectors.

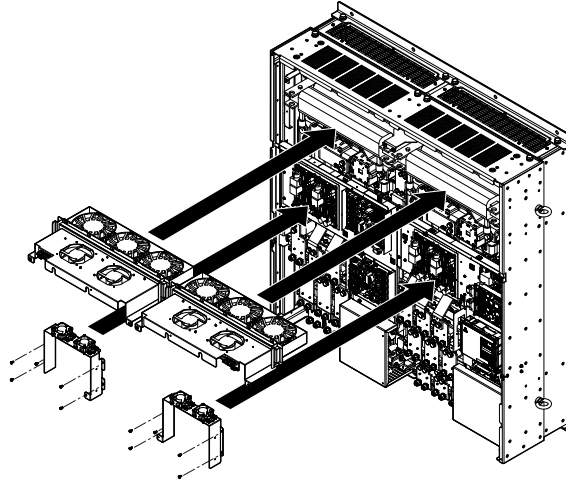

Figure 7.51 Install the Cooling Fan Unit: 4A0930 and 4A1200

2. Reattach the covers and digital operator.
3. Turn on the power supply and set o4-03 to 0 to reset the Maintenance Monitor cooling fan operation time.

7.5 Replacing the Air Filter

Drive models 4A0930 and 4A1200 have a built-in air filter.

Contact a Yaskawa representative or the nearest Yaskawa sales office to order new replacement air filters as necessary.

Follow the instructions below to remove and replace the air filter.

◆ Air Filter Replacement

WARNING! Electrical Shock Hazard. Do not connect or disconnect wiring while the power is on. Failure to comply can result in serious personal injury. Before servicing the drive, disconnect all power to the equipment. The internal capacitor remains charged even after the power supply is turned off. After shutting off the power, wait for at least the amount of time specified on the drive before touching any components.

CAUTION! Burn Hazard. Do not touch a hot drive heatsink. Failure to comply could result in minor or moderate injury. Shut off the power to the drive when replacing the cooling fan. To prevent burns, wait at least 15 minutes and ensure the heatsink has cooled down.

NOTICE: Follow air filter replacement instructions. Improper air filter replacement may cause damage to equipment. Replace all filters when performing maintenance to help ensure maximum useful product life.

■ Removing the Air Filter

1. Remove the terminal cover.
2. Remove the screws holding the blind cover in place on the bottom of the drive. Pull forward on the blind cover to free it from the drive.

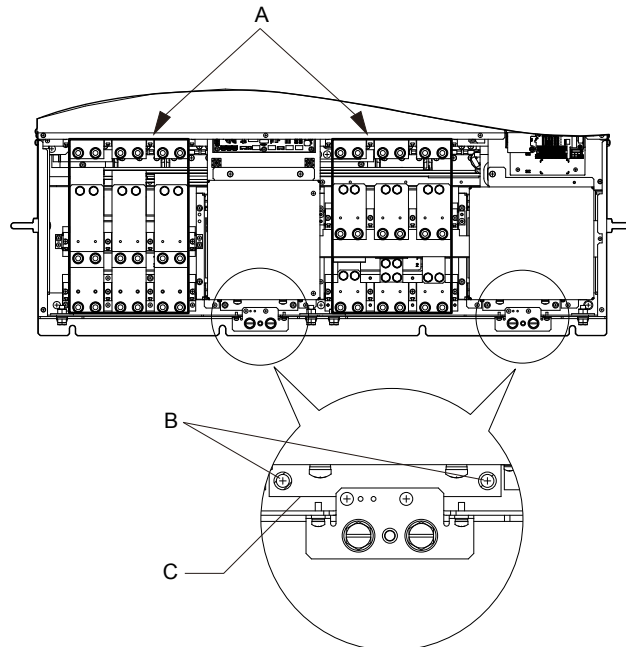

A – Main circuit terminals
B – Blind cover screws

C – Blind cover

Figure 7.52 Remove the Blind Cover

3. Loosen the screws holding the filter case in place. Do not remove the screws.

Note: Only loosen the filter case; it should not be removed.

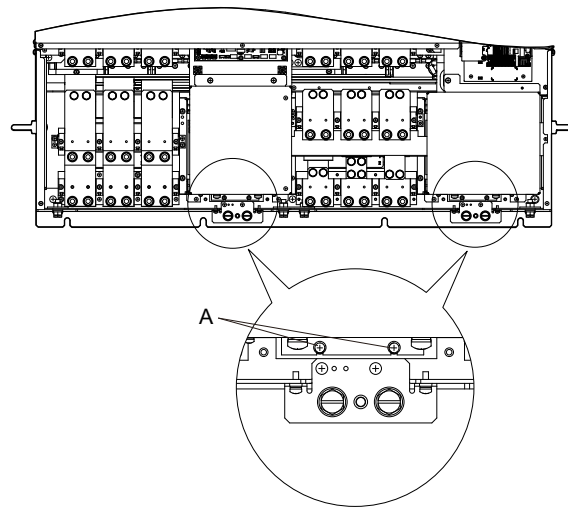

A –Screws holding filter case

Figure 7.53 Loosen the Filter Case Screws

4. Hold the bottom of the filter case and slide it out from the drive.

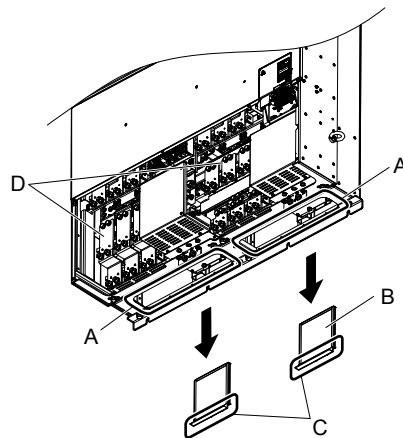

A – Opening
B – Filter case

C – Hold the filter case here
to slide it out
D – Main circuit terminals

Figure 7.54 Slide Out the Filter Case

5. Remove the filter from the filter case

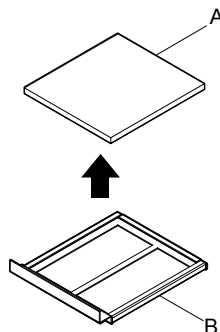

A – Air filter

B – Filter case

Figure 7.55 Remove the Air Filter

■ Installing the Air Filter

Reverse the procedure described above to reinstall the air filter.

7.6 Drive Replacement

◆ Serviceable Parts

The drive contains some serviceable parts. The following parts can be replaced over the life span of the drive:

- Terminal board I/O PCBs
- Cooling fan(s)
- Front cover

Replace the drive if the main power circuitry is damaged. Contact your local Yaskawa representative before replacing parts if the drive is still under warranty. Yaskawa reserves the right to replace or repair the drive according to Yaskawa warranty policy.

◆ Terminal Board

The drive has a modular I/O terminal block that facilitates quick drive replacement. The terminal board contains on-board memory that stores all drive parameter settings and allows the parameters to be saved and transferred to the replacement drive. To transfer the terminal board, disconnect the terminal board from the damaged drive and reconnect it to the replacement drive. There is no need to manually reprogram the replacement drive after transferring the terminal board.

Note: If the damaged drive and the new replacement drive have different capacities, the data stored in the terminal board cannot be transferred to the new drive and an oPE01 error will appear on the display. The terminal board can still be used, but parameter setting from the old drive cannot be transferred. The replacement drive must be initialized and manually programmed.

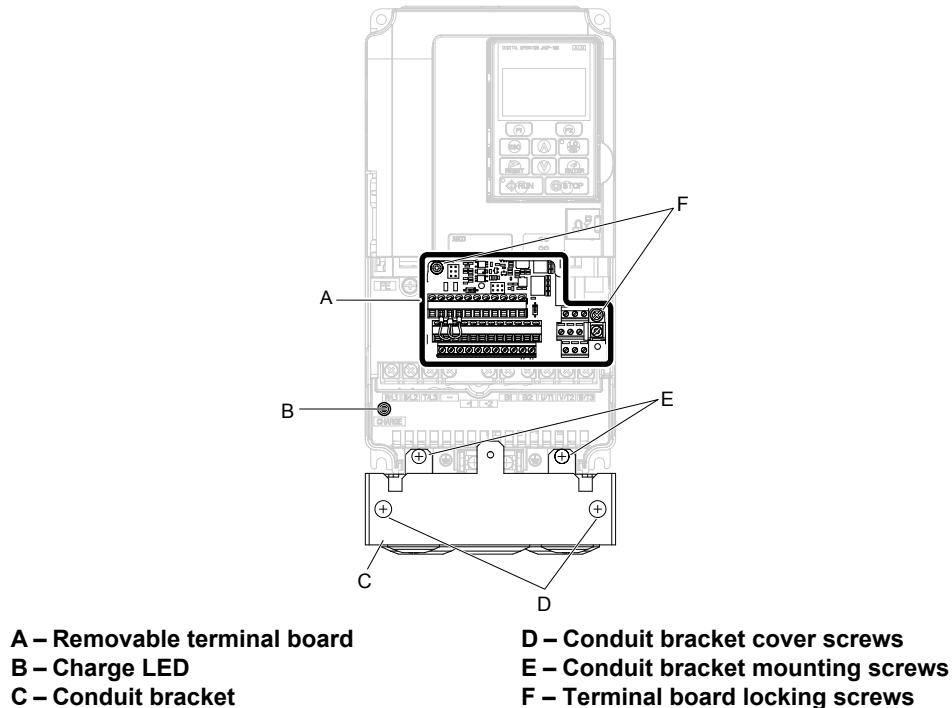

Figure 7.56 Terminal Board

◆ Replacing the Drive

WARNING! Electrical Shock Hazard. Do not connect or disconnect wiring while the power is on. Failure to comply can result in serious personal injury. Before servicing the drive, disconnect all power to the equipment. The internal capacitor remains charged even after the power supply is turned off. After shutting off the power, wait for at least the amount of time specified on the drive before touching any components.

WARNING! Electrical Shock Hazard. Do not allow unqualified personnel to perform work on the drive. Failure to comply could result in serious injury. Installation, maintenance, inspection and servicing must be performed only by authorized personnel familiar with installation, adjustment and maintenance of AC drives.

NOTICE: Observe proper electrostatic discharge procedures (ESD) when handling the drive and circuit boards. Failure to comply may result in ESD damage to the drive circuitry.

The following procedure explains how to replace a drive.

This section provides instructions for drive replacement only.

To install option boards or other types of options, refer to the specific manuals for those options.

NOTICE: When transferring a braking transistor, braking resistor, or other type of option from a damaged drive to a new replacement drive, make sure it is working properly before reconnecting it to the new drive. Replace broken options to prevent immediate breakdown of the replacement drive.

1. Remove the terminal cover.

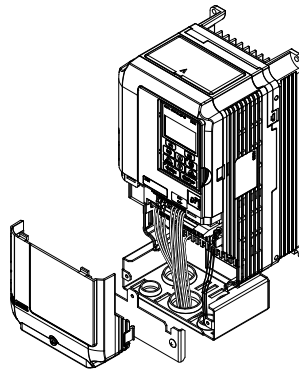

Figure 7.57 Remove the Terminal Cover

2. Loosen the screws holding the terminal board in place. Remove the screw securing the bottom cover and remove the bottom cover from the drive.

Note: IP00/Open Type enclosure drives do not have a bottom cover or conduit.

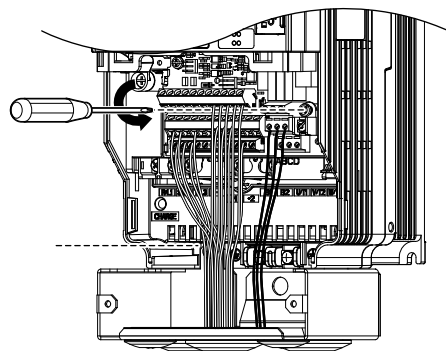

Figure 7.58 Unscrew the Terminal Board and Remove the Bottom Cover

3. Slide the terminal board as illustrated by the arrows to remove it from the drive along with the bottom cover.

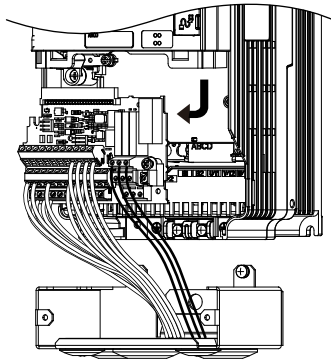

Figure 7.59 Remove the Terminal Board

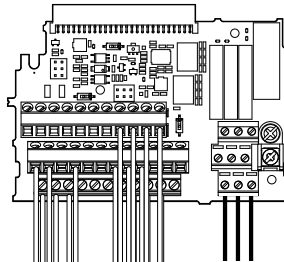

Figure 7.60 Disconnected Removable Terminal Board

4. Disconnect all option cards and options, making sure they are intact before reusing.
5. Replace the drive and wire the main circuit.

■ Installing the Drive

1. After wiring the main circuit, connect the terminal block to the drive as shown in [Figure 7.61](#). Use the installation screw to fasten the terminal block into place.

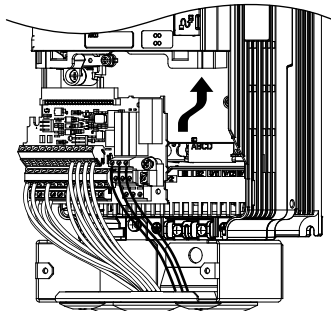

Figure 7.61 Install the Terminal Board

2. Reconnect options for the new drive the same way the options were connected in the old drive. Connect option boards to the same option ports in the new drive that were used in the old drive.
3. Replace the terminal cover.
4. After powering on the drive, all parameter settings are transferred from the terminal board to the drive memory. If an oPE04 error occurs, load the parameter settings saved on the terminal board to the new drive by setting parameter A1-03 to 5550. Reset the Maintenance Monitor function timers by setting parameters o4-01 through o4-12 to 0, and parameter o4-13 to 1.

Peripheral Devices & Options

This chapter explains the installation of peripheral devices and options available for the drive.

8.1	SECTION SAFETY.....	436
8.2	DRIVE OPTIONS AND PERIPHERAL DEVICES.....	437
8.3	CONNECTING PERIPHERAL DEVICES.....	439
8.4	OPTION INSTALLATION.....	440
8.5	INSTALLING PERIPHERAL DEVICES.....	449

8.1 Section Safety

DANGER

Electrical Shock Hazard

Do not connect or disconnect wiring while the power is on.

Failure to comply will result in death or serious injury.

The internal capacitor remains charged even after the power supply is turned off. After shutting off the power, wait for at least the amount of time specified on the drive before touching any components.

WARNING

Electrical Shock Hazard

Do not operate equipment with covers removed.

Failure to comply could result in death or serious injury.

The diagrams in this section may show drives without covers or safety shields to show details. Be sure to reinstall covers or shields before operating the drives and run the drives according to the instructions described in this manual.

Do not remove covers or touch circuit boards while the power is on.

Failure to comply could result in death or serious injury.

Do not allow unqualified personnel to perform work on the drive.

Failure to comply could result in death or serious injury.

Installation, maintenance, inspection and servicing must be performed only by authorized personnel familiar with installation, adjustment and maintenance of AC drives.

Do not perform work on the drive while wearing loose clothing, jewelry or without eye protection.

Failure to comply could result in death or serious injury.

Remove all metal objects such as watches and rings, secure loose clothing and wear eye protection before beginning work on the drive.

Always ground the motor-side grounding terminal.

Improper equipment grounding could result in death or serious injury by contacting the motor case.

Fire Hazard

Tighten all terminal screws to the specified tightening torque.

Loose electrical connections could result in death or serious injury by fire due to overheating of electrical connections.

NOTICE

Observe proper electrostatic discharge procedures (ESD) when handling the drive and circuit boards.

Failure to comply may result in ESD damage to the drive circuitry.

Never connect or disconnect the motor from the drive while the drive is outputting voltage.

Improper equipment sequencing could result in damage to the drive.

If a fuse is blown or a Ground Fault Circuit Interrupter (GFCI) is tripped, check the wiring and the selection of the peripheral devices.

Contact your supplier if the cause cannot be identified after checking the above.

Do not restart the drive or immediately operate the peripheral devices if a fuse is blown or a GFCI is tripped.

Check the wiring and the selection of peripheral devices to identify the cause. Contact your supplier before restarting the drive or the peripheral devices if the cause cannot be identified.

8.2 Drive Options and Peripheral Devices

Table 8.1 lists the names of the various peripheral devices, accessories, and options available for Yaskawa drives. Contact Yaskawa or your Yaskawa agent to order these peripheral devices.

- **Peripheral Device Selection:** Refer to the Yaskawa catalog for selection and part numbers.
- **Peripheral Device Installation:** Refer to the corresponding option manual for installation instructions.

Table 8.1 Available Peripheral Devices

Option	Model Number	Description
Power Options		
DC link choke	–	Improves the power factor by suppressing harmonic distortion from the power supply.
AC Reactor	–	Protects the drive when operating from a large power supply and improves the power factor by suppressing harmonic distortion. Highly recommended for power supplies that exceed 600 kVA.
Braking Resistor	–	For use with systems that require dynamic braking with up to 3% ED. If higher ED is required, use a Braking Resistor Unit. Note: Not rated for 600 V class drive models.
Input/Output Option Cards		
Analog Input	AI-A3	<ul style="list-style-type: none"> • Allows high precision, high resolution analog reference input • Input channels: 3 • Voltage input: -10 to 10 Vdc (20 kΩ), 13-bit signed • Current input: 4 to 20 mA or 0 to 20 mA (250 kΩ), 12-bit
Analog Monitor	AO-A3	<ul style="list-style-type: none"> • Provides extra multi-function analog output terminals • Output channels: 2 • Output voltage: -10 to 10 V, 11-bit (signed)
Digital Input	DI-A3	<ul style="list-style-type: none"> • Sets the frequency reference by digital inputs • Input channels: 18 (including SET signal and SIGN signal) • Input signal type: BCD 16-bit (4-digit), 12-bit (3-digit), 8-bit (2-digit) • Input signal: 24 Vdc, 8 mA
Digital Output	DO-A3	<ul style="list-style-type: none"> • Provides extra insulated multi-function digital outputs • Photocoupler relays: 6 (48 V, up to 50 mA) • Contact relays: 2 (250 Vac/up to 1 A, 30 Vdc/up to 1 A)
Motor Speed Feedback Option Cards		
Motor PG Feedback Line Driver Interface	PG-X3	<ul style="list-style-type: none"> • For speed feedback input by connecting a motor encoder • Input: 3-track (can be used with 1 or 2 tracks), line driver, 300 kHz max • Output: 3-track, line driver • Encoder power supply: 5 V or 12 V, max current 200 mA
Motor PG Feedback Open Collector Interface	PG-B3	<ul style="list-style-type: none"> • For speed feedback input by connecting a motor encoder • Input: 3-track (can be used with 1 or 2 tracks), HTL encoder connection, 50 kHz max • Output: 3-track, open collector • Encoder power supply: 12 V, max current 200 mA
Motor Feedback Resolver Interface	PG-RT3	<ul style="list-style-type: none"> • For motor speed feedback by connecting a resolver that meets the specifications set by Yaskawa. • Input voltage: 7 Vac rms 10 kHz • Transformation ratio: $0.5 \pm 5\%$ • Maximum input current: 100 mA rms <p>Note:</p> <ol style="list-style-type: none"> 1. Available in drive software versions PRG: 1017 and later. 2. Not available with drive models 4A0930 and 4A1200.
Communication Option Cards		
EtherNet/IP	SI-EN3	Connects to an EtherNet/IP network.
Modbus TCP/IP	SI-EM3	Connects to a Modbus TCP/IP network.
DeviceNet	SI-N3	Connects to a DeviceNet network
PROFIBUS-DP	SI-P3	Connects to a PROFIBUS-DP network.
MECHATROLINK-II	SI-T3	Connects to a MECHATROLINK-II network.
BACnet	SI-B3	Connects to a BACnet network.
CC-Link </>	SI-C3	Connects to a CC-Link network

8.2 Drive Options and Peripheral Devices

Option	Model Number	Description
CANopen <1>	SI-S3	Connects to a CANopen network.
Interface Options		
LED Operator	JVOP-182	5-digit LED operator; max. cable length for remote usage: 3 m
Remote Operator Cable	UWR000051, 1 m cable UWR000052, 2 m cable	RJ-45, 8-pin straight through, UTP CAT5e, extension cable (1 m or 2 m) to connect the digital operator for remote operation.
USB Copy Unit	JVOP-181	<ul style="list-style-type: none"> Allows the user to copy and verify parameter settings between drives. Functions as an adapter to connect the drive to a USB port on a PC.
Mechanical Options		
Attachment for External Heatsink	EZZ020800A/B/C/D	Installation kit for mounting the drive with the heatsink outside of the panel (Side-by-Side mounting possible)
IP20/NEMA Type 1 Kit	100-054-503 100-054-504	Parts to make the drive conform to IP20/NEMA Type 1 enclosure requirements.
IP20/NEMA Type 1, 4, 12 Blank Keypad Kit	UUX0000526	Provides digital operator (JVOP-180, JVOP-182) functionality on an enclosure designed for IP20/NEMA Type 1, 3R, 4, 4X, 12, or IP□6 environment. This keypad has a blank label on the front.
IP20/NEMA Type 1, 4, 12 Yaskawa Logo Keypad Kit	UUX0000527	Provides digital operator (JVOP-180, JVOP-182) functionality on an enclosure designed for IP20/NEMA Type 1, 3R, 4, 4X, 12, or IP□6 environment. This keypad has a Yaskawa brand label on the front.
Others		
24 V Power Supply	200 V Class: PS-A10LB 400 V Class: PS-A10HB 600 V Class: PS-A10HB	Supplies the drive controller with 24 Vdc power during main power loss.
PC Software Tools		
DriveWizard 2010	Contact Yaskawa	PC tool for drive setup and parameter management
DriveWorksEZ	Contact Yaskawa	PC tool for enhanced programming of the drive

<1> Limited support. Contact a Yaskawa representative or the nearest Yaskawa sales office for assistance.

8.3 Connecting Peripheral Devices

Figure 8.1 illustrates how to configure the drive and motor to operate with various peripheral devices. Refer to the specific manual for the devices shown below for more detailed installation instructions.

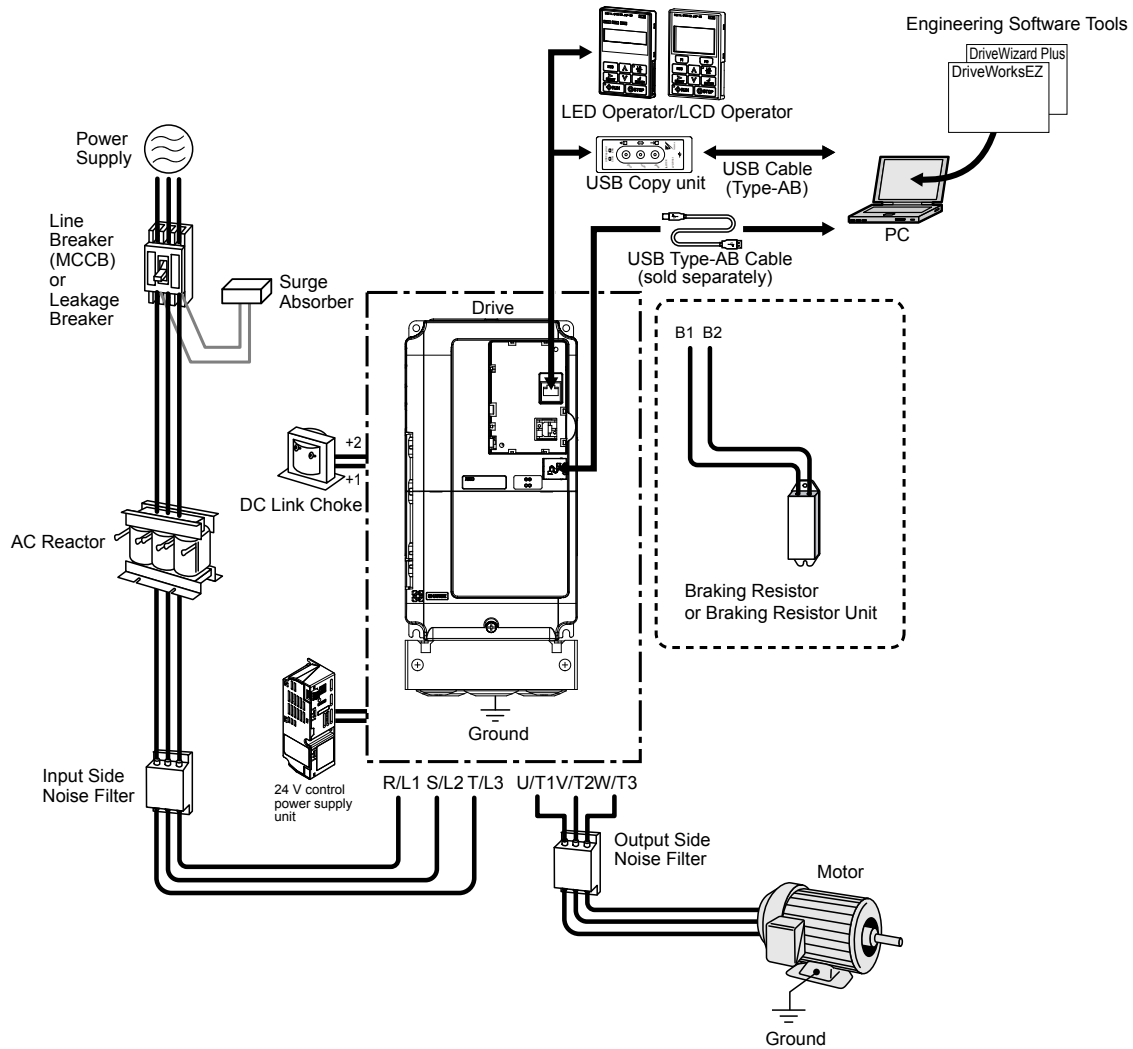

Figure 8.1 Connecting Peripheral Devices

Note: If the drive is set to trigger a fault output when the fault restart function is activated ($L5-02 = 1$), then a sequence to interrupt power when a fault occurs will turn off the power to the drive while the drive attempts to restart. The default setting for L5-02 is 0 (fault output active during restart).

8.4 Option Installation

This section provides instructions on installing the options in [Table 8.2](#).

◆ Prior to Installing the Option

Prior to installing the option, wire the drive, make necessary connections to the drive terminals, and verify that the drive functions normally without the option installed.

[Table 8.2](#) below lists the number of options that can be connected to the drive and the drive ports for connecting those options.

Table 8.2 Option Installation

Option	Port/Connector	Number of Options Possible
SI-B3, SI-EN3, SI-EM3, SI-N3, SI-P3, SI-T3, SI-C3, SI-S3, AI-A3 <1>, DI-A3 <1>	CN5-A	1
PG-X3, PG-B3	CN5-B, C	2 <2>
PG-RT3 <3> <4> <5>	CN5-C	1
DO-A3, AO-A3	CN5-A, B, C	1

<1> Options AI-A3 and DI-A3 cannot set the frequency reference when installed to ports CN5-B or CN5-C. It is still possible, however, to view the input status using U1-21, U1-22, U1-23 (for AI-A3), and U1-17 (for DI-A3).

<2> Use port CN5-C when connecting one PG option. Use ports CN5-B and CN5-C when connecting two PG options.

<3> Refer to the option installation manual TOBP C730600 53 for details.

<4> PG-RT3 is not available for the application with Motor 2 selection.

<5> PG-RT3 is not available for drive models 4A0930 and 4A1200.

[Figure 8.2](#) shows an exploded view of the drive with the option and related components for reference.

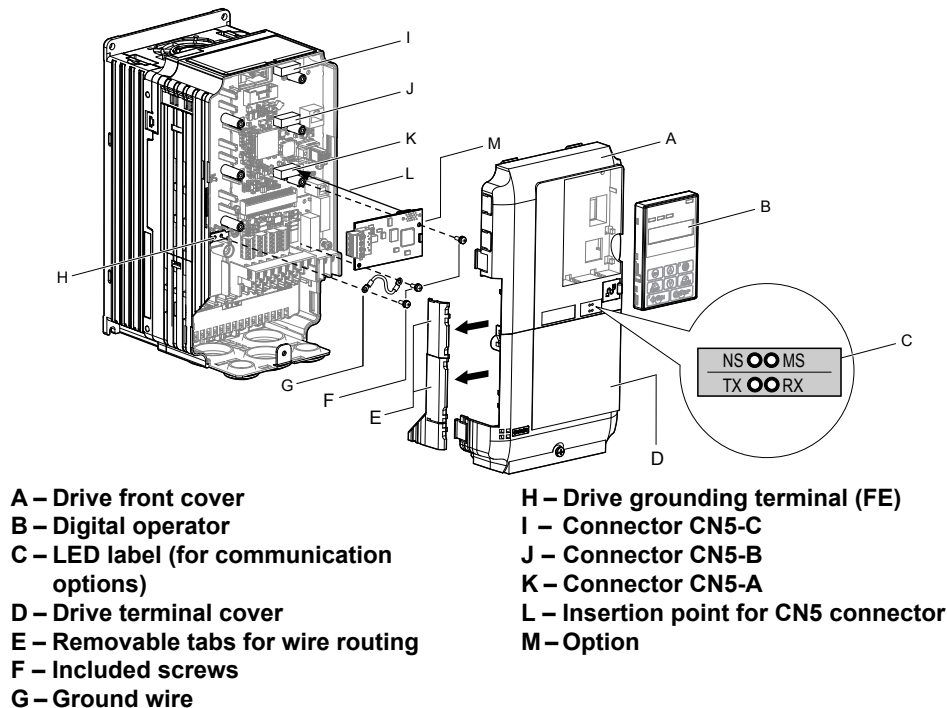

Figure 8.2 Drive Components with Option

◆ PG Option Installation Example

Remove the front covers of the drive before installing the option. PG options can be inserted into the CN5-B or CN5-C connectors located on the drive control board.

Preparing the Drive

1. Shut off power to the drive, wait the appropriate amount of time for voltage to dissipate, then remove the digital operator (B) and front covers (A, D). Front cover removal varies by model.

DANGER! *Electrical Shock Hazard. Do not connect or disconnect wiring while the power is on. Failure to comply will result in death or serious injury. Before installing the option, disconnect all power to the drive. The internal capacitor remains charged even after the power supply is turned off. The charge indicator LED will extinguish when the DC bus voltage is below 50 Vdc. To prevent electric shock, wait at least five minutes after all indicators are off and measure the DC bus voltage level to confirm safe level.*

NOTICE: *Damage to Equipment. Observe proper electrostatic discharge procedures (ESD) when handling the option, drive, and circuit boards. Failure to comply may result in ESD damage to circuitry.*

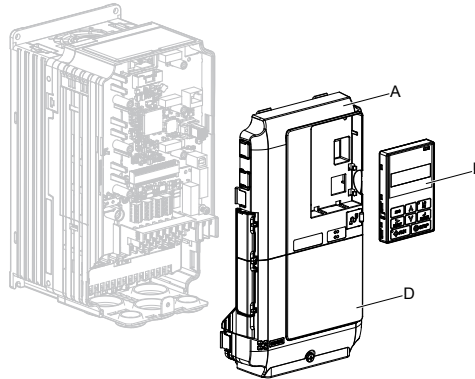

Figure 8.3 Remove the Front Covers and Digital Operator

Wiring the Option

1. Insert the option (M) into the **CN5-B** or **CN5-C** connector (I, J) located on the drive and fasten it using one of the included screws (F). If connecting only one PG option, use the **CN5-C** connector.

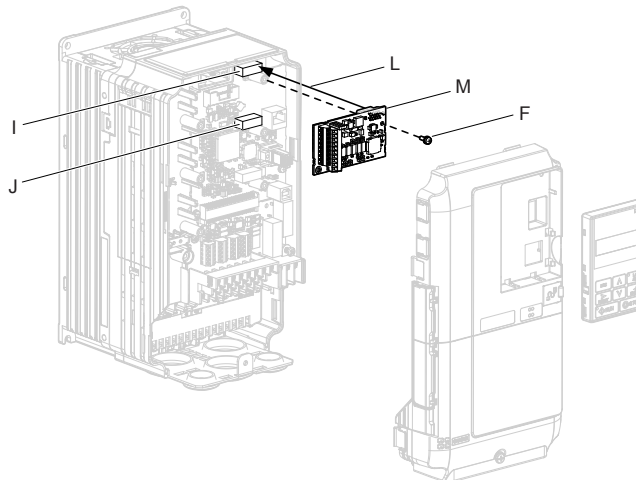

Figure 8.4 Insert the Option

2. Connect the ground wire (G) to the ground terminal (H) using one of the remaining provided screws (F). Connect the other end of the ground wire (G) to the remaining ground terminal and installation hole on the option (M) using the last remaining provided screw (F) and tighten both screws to 0.5 ~ 0.6 N m or (4.4 ~ 5.3 in lbs).

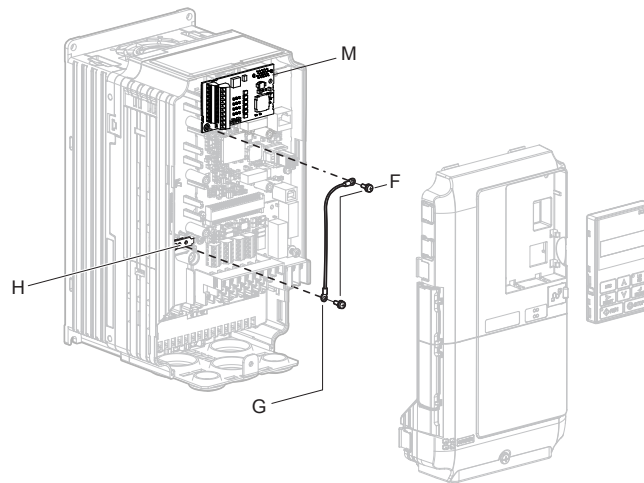

Figure 8.5 Connect the Ground Wire

- Note:**
1. The option package includes two ground wires. Use the longer wire when plugging the option into connector CN5-C on the drive side. Use the shorter wire when plugging the option into connector CN5-B. Refer to the Option Installation manual for more information.
 2. There are two screw holes on the drive for use as ground terminals. When connecting three options, two ground wires will need to share the same drive ground terminal.
- 3.** Prepare and connect the wire ends as shown in [Figure 8.6](#) and [Figure 8.7](#). Refer to [Wire Gauges and Tightening Torques of PG-B3 and PG-X3 Options on page 447](#) to confirm that the proper tightening torque is applied to each terminal. Take particular precaution to ensure that each wire is properly connected and that wire insulation is not accidentally pinched into electrical terminals.

WARNING! Fire Hazard. Tighten all terminal screws according to the specified tightening torque. Loose electrical connections could result in death or serious injury by fire due to overheating electrical connections. Tightening screws beyond the specified tightening torque may result in erroneous operation, damage to the terminal block, or cause a fire.

NOTICE: Heat shrink tubing or electrical tape may be required to ensure that cable shielding does not contact other wiring. Insufficient insulation may cause a short circuit and damage the option or drive.

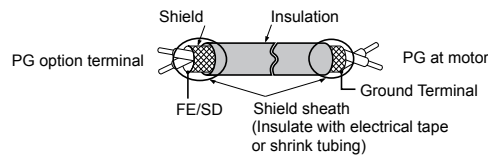

Figure 8.6 Preparing Ends of Shielded Cable

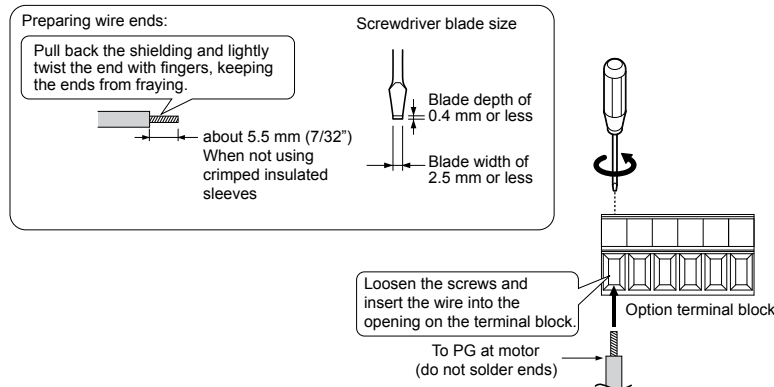

Figure 8.7 Preparing and Connecting Cable Wiring

- 4.** Wire the motor PG encoder to the terminal block on the option. Refer to [Figure 8.8](#) and [Figure 8.9](#) for wiring instructions.

Refer to *Terminal Functions of PG-B3 and PG-X3 Options on page 448* for a detailed description of the option terminal functions.

■ Parameter Settings and Connections for Different Encoder Types

Connecting a Single-Pulse Encoder

When using a single-pulse encoder in V/f with PG control mode, connect the pulse output from the PG to the option and set drive parameter F1-21 to 0.

Connecting a Two-Pulse Encoder

When using a two-pulse encoder, connect the A and B pulse outputs on the PG to the option and set F1-21 to 1.

When using a two-pulse encoder in Closed Loop Vector control mode, connect pulse outputs A and B from the encoder to the corresponding terminals on the option.

Connecting a Two-Pulse Encoder with Z Marker Pulse

When using a two-pulse encoder with Z marker pulse, connect the A, B, and Z pulse outputs to the corresponding terminals on the option.

Control Method	V/f with PG		Closed Loop Vector	
No. of Encoders	1 (CN5-C)	2 (CN5-B)	1 (CN5-C)	2 (CN5-B)
Single Pulse (A)	F1-21 = 0	F1-37 = 0	N/A	N/A
Two Pulse (AB Quadrature)	F1-21 = 1	F1-37 = 1	No setting required	No setting required
Two Pulse with Marker (ABZ)	F1-21 = 1	F1-37 = 1	No setting required	No setting required

PG-B3 Connection Diagram

Refer to *Terminal Functions of PG-B3 and PG-X3 Options on page 448* for a detailed description of the option board terminal functions.

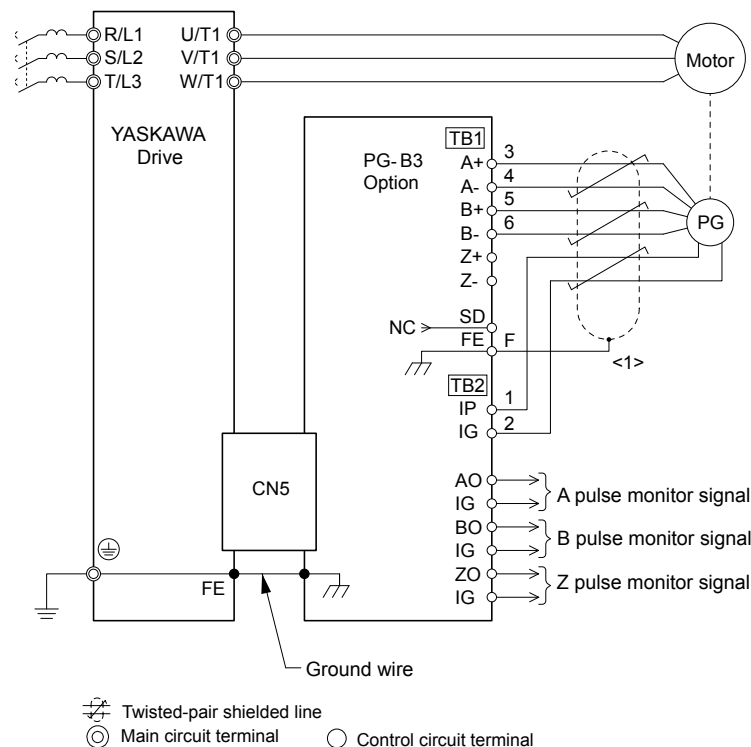

Figure 8.8 PG-B3 Option and Encoder Connection Diagram

<1> The PG-B3 option reads a maximum input frequency of 50 kHz from the PG encoder. Select a PG encoder with a maximum output of 50 kHz when operating at maximum speed.

8.4 Option Installation

PG-X3 Connection Diagram

Refer to *Terminal Functions of PG-B3 and PG-X3 Options on page 448* for a detailed description of the option board terminal functions.

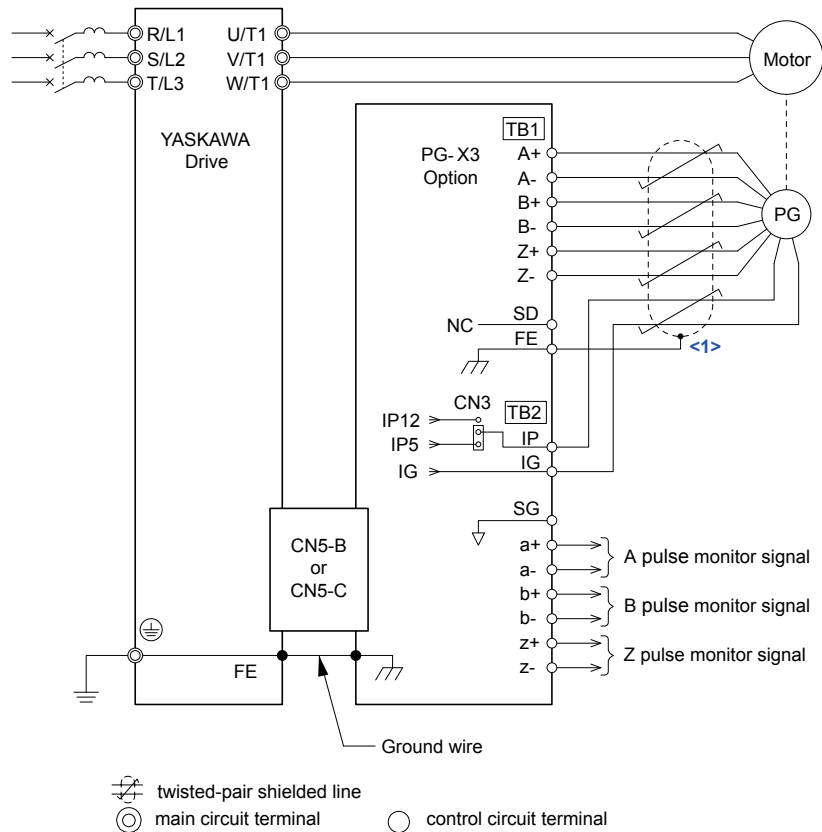

Figure 8.9 PG-X3 Option and Encoder Connection Diagram

<1> The PG-B3 option reads a maximum input frequency of 300 kHz from the PG encoder. Select a PG encoder with a maximum output of 300 kHz when operating at maximum speed.

PG Encoder Cables for PG-B3 Option

Yaskawa recommends using a LMA-□□B-S185Y (complementary output) for cables running between the option and the PG as shown in *Figure 8.10*.

Refer to *Terminal Functions of PG-B3 and PG-X3 Options on page 448* for instructions on wiring the terminal block.

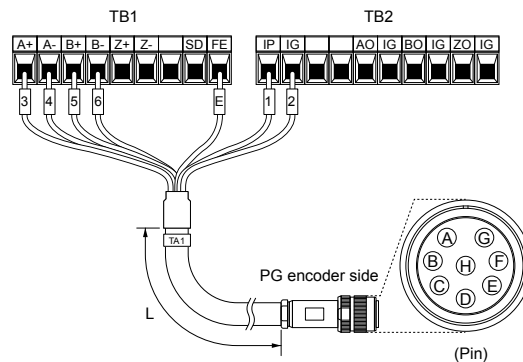

Figure 8.10 Wiring the PG Encoder Cable

Table 8.3 Connecting the PG Encoder Cable Specification

Option Terminal	PG Encoder Cable		
	Wire	Color	Pin
IP	1	Blue	C
IG	2	White	H
A+	3	Yellow	B
A-	4	White	G
B+	5	Green	A
B-	6	White	F
FE	E	N/A (shield)	D

Table 8.4 PG Encoder Cable Types

Length	Type	Length	Type
10 m (32 ft.)	W5010	50 m (164 ft.)	W5050
30 m (98 ft.)	W5030	100 m (328 ft.)	W5100

- Set the voltage for the PG encoder power supply using jumper CN3 located on the option. Position the jumper as shown in [Table 8.5](#) to select the voltage level.

NOTICE: The positioning of jumper CN3 selects the PG encoder power supply voltage (5.0 V or 8V). Select the voltage level for the PG encoder connected to the option and motor. If the wrong voltage is selected, the PG encoder may not operate properly or may become damaged as a result.

Table 8.5 Setting the PG Encoder Power Supply Voltage (IP) with Jumper CN3

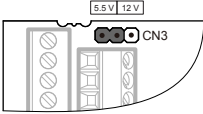
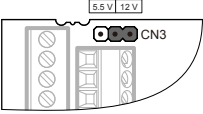
Voltage Level	5.0 V \pm 5% (default)	8 V \pm 10%
Jumper CN3		

- Route the option wiring.

Depending on the drive model, some drives may require routing the wiring through the side of the front cover to the outside to provide adequate space for the wiring. In these cases, using diagonal cutting pliers, cut out the perforated openings on the left side of the drive front cover. Sharp edges along the cut out should be smoothed down with a file or sand paper to prevent any damage to the wires.

Route the communication wiring inside the enclosure for drives that do not require routing through the front cover. Refer to [Table 8.6](#) and [Figure 8.11](#) to determine the proper wire routing by drive model.

Table 8.6 Communication Wire Routing Selection

Drive Series	Model	Wire Routing <1>	
		Through Front Cover	Inside Drive
A1000	Models 2A0004 to 2A0040; 4A0002 to 4A0023; 5A0003 to 5A0011	Figure 8.11 (A)	–
A1000	Models 2A0056 and above; 4A0031 and above; 5A0023 and above	–	Figure 8.11 (B)

<1> Refer to [Figure 8.11](#) for examples of the different wire routing techniques.

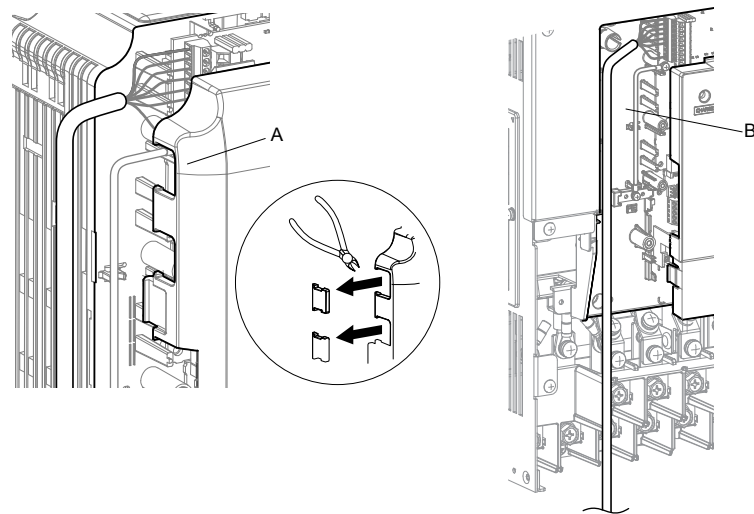

A – Route wires through the openings provided on the left side of the front cover. <1>

B – Use the open space provided inside the drive to route option wiring.

Figure 8.11 Wire Routing Examples

<1> The drive will not meet NEMA Type 1 requirements if wiring is exposed outside the enclosure.

Replacing the Drive Covers and Digital Operator

1. Replace and secure the front covers of the drive (A, D) and replace the digital operator (B).

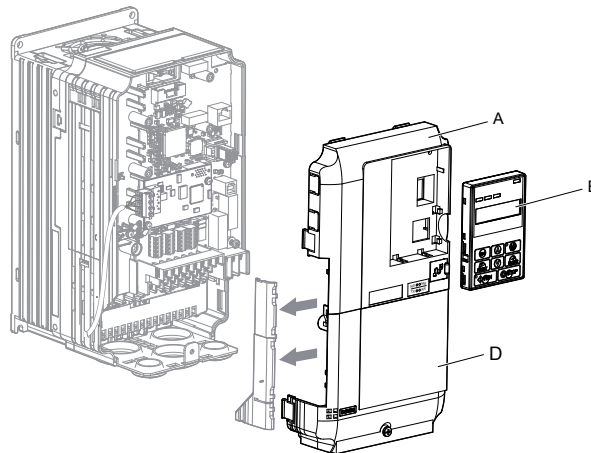

Figure 8.12 Replace the Front Covers and Digital Operator

Note: Take proper precautions when wiring the option so that the front covers will easily fit back onto the drive. Make sure no cables are pinched between the front covers and the drive when replacing the covers.

Checking for Proper Motor Rotation

1. Set drive parameters A1-02 and the F1: PG Speed Control parameters for proper motor rotation. ([Refer to A1: Initialization on page 493](#) and [Refer to F1: PG Speed Control Card \(PG-X3/PG-B3\) on page 520](#) for details on parameter settings) With a two-pulse or three-pulse PG encoder, the leading pulse determines the motor rotation direction. A PG encoder signal with leading A pulse is considered to be rotating forward (counter-clockwise when viewing rotation from motor load side).

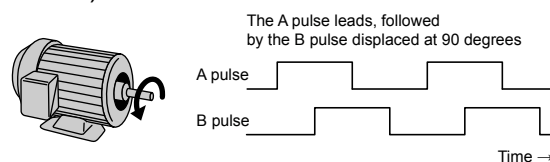

Figure 8.13 Displacement of A and B Pulses

After connecting the PG encoder outputs to the option, apply power to the drive and manually rotate the motor and check the rotation direction by viewing monitor U1-05 on the digital operator.

Reverse motor rotation is indicated by a negative value for U1-05; forward motor rotation is indicated by a positive value.

If monitor U1-05 indicates that the forward direction is opposite of what is intended, set F1-05 or F1-32 to 1 or reverse the two A pulse wires with the two B pulse wires on option terminal TB1 as shown in [Figure 8.14](#).

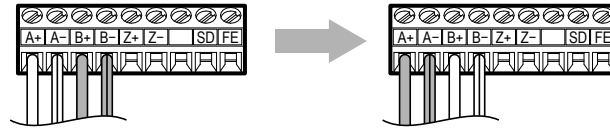

Figure 8.14 A Channel and B Channel Wire Switching

Please note that when the drive is initialized using A1-03 = 1110, 2220, 3330, the value for F1-05 will reset to factory default and the parameter will need to be readjusted to switch the direction.

■ Wire Gauges and Tightening Torques of PG-B3 and PG-X3 Options

Wire gauge and torque specifications are listed in [Table 8.7](#) and [Table 8.8](#).

Table 8.7 Wire Gauges and Tightening Torques of PG-B3 Option

Terminal Signal	Screw Size	Tightening Torque N·m (in·lb)	Bare Cable		Crimp Terminals		Wire Type
			Applicable Gauges mm ²	Recomm. Gauge mm ²	Applicable Gauges mm ²	Recomm. Gauge mm ²	
A+, A-, B+, B-, Z+, Z-, FE, IP, IG	M2	0.22 to 0.25 (1.95 to 2.21)	Stranded wire: 0.25 to 1.0 (24 to 17 AWG) Solid wire: 0.25 to 1.5 (24 to 16 AWG)	0.75 (18 AWG)	0.25 to 0.5 (24 to 20 AWG)	0.5 (20 AWG)	Shielded twisted pair, etc.
AO, IG, BO, IG, ZO, IG							Shielded cable, etc.

Table 8.8 Wire Gauges and Tightening Torques of PG-X3 Option

Terminal Signal	Screw Size	Tightening Torque N·m (in·lb)	Bare Cable		Crimp Terminals		Wire Type
			Applicable Gauges mm ²	Recomm. Gauge mm ²	Applicable Gauges mm ²	Recomm. Gauge mm ²	
A+, A-, B+, B-, Z+, Z-, SD, FE, IP, IG	M2	0.22 to 0.25 (1.95 to 2.21)	Stranded wire: 0.25 to 1.0 (24 to 17 AWG) Solid wire: 0.25 to 1.5 (24 to 16 AWG)	0.75 (18 AWG)	0.25 to 0.5 (24 to 20 AWG)	0.5 (20 AWG)	Shielded twisted pair, etc.
a+, a-, b+, b-, z+, z-, SG							Shielded cable, etc.

■ Crimp Terminals

Yaskawa recommends using CRIMPFOX 6 by Phoenix Contact or equivalent crimp terminals with the specifications listed in [Table 8.9](#) for wiring to ensure proper connections.

Note: Properly trim wire ends so loose wire ends do not extend from the crimp terminals.

Table 8.9 Crimp Terminal Sizes

	Wire Gauge mm ²	Phoenix Contact Model	L mm (in)	d1 mm (in)	d2 mm (in)
	0.25 (24 AWG)	AI 0.25 - 6YE	10.5 (13/32)	0.8 (1/32)	2 (5/64)
	0.34 (22 AWG)	AI 0.34 - 6TQ	10.5 (13/32)	0.8 (1/32)	2 (5/64)
	0.5 (20 AWG)	AI 0.5 - 6WH	14 (9/16)	1.1 (3/64)	2.5 (3/32)

◆ Terminal Functions of PG-B3 and PG-X3 Options

Table 8.10 PG-B3 Option Terminal Functions

Terminal Block	Terminal	Function	Description
TB1	A+	A+ pulse signal input	Pulse signal inputs from the PG. Signal inputs from complementary and open-collector outputs Signal level H level: 8 to 12 V L level: 2.0 V or less
	A-	A- pulse signal input	
	B+	B+ pulse signal input	
	B-	B- pulse signal input	
	Z+	Z+ pulse signal input	
	Z-	Z- pulse signal input	
	SD	NC pin (open)	For use when cables shields should not be grounded
	FE	Ground	Used for grounding shielded lines
TB2	IP	PG power supply	Output voltage: 12.0 V ± 5% Max output current: 200 mA <1>
	IG	PG power supply common	
	AO	A pulse monitor signal	Outputs the monitor signal for the A, B, and Z pulses from the PG speed control card For open collector outputs from the option Max voltage: 24 V Max current: 30 mA
	BO	B pulse monitor signal	
	ZO	Z pulse monitor signal	
	IG	Monitor signal common	

<1> A separate UL-listed class 2 power supply is necessary when the PG requires more than 200 mA to operate.

Table 8.11 PG-X3 Option Terminal Functions

Terminal Block	Terminal	Function	Description
TB1	A+	A pulse signal input	Inputs for the A channel, B channel, and Z pulses from the PG encoder, Signal level matches RS-422
	A-	A inverse pulse signal input	
	B+	B pulse signal input	
	B-	B inverse pulse signal input	
	Z+	Z pulse signal input	
	Z-	Z inverse pulse signal input	
	SD	NC pin (open)	Open connection port for use when cable shields should not be grounded
	FE	Ground	Used as the shield ground termination point.
TB2	IP	PG encoder power supply	Output voltage: 12.0 V ± 5% or 5.5 V ± 5% Max. output current: 200 mA <1>
	IG	PG encoder power supply common	
	SG	Monitor signal common	Output signal for monitoring A channel, B channel, and Z pulses from the PG encoder, Signal level matches RS-422
	a+	A pulse monitor signal	
	a-	A pulse inverse monitor signal	
	b+	B pulse monitor signal	
	b-	B pulse inverse monitor signal	
	z+	Z pulse monitor signal	
	z-	Z pulse inverse monitor signal	

<1> A separate UL-listed class 2 power supply is necessary when the PG requires more than 200 mA to operate.

8.5 Installing Peripheral Devices

This section describes the proper steps and precautions to take when installing or connecting various peripheral devices to the drive.

NOTICE: Use a class 2 power supply when connecting to the control terminals. Improper application of peripheral devices could result in drive performance degradation due to improper power supply. Refer to NEC Article 725 Class 1, Class 2, and Class 3 Remote-Control, Signaling, and Power Limited Circuits for requirements concerning class 2 power supplies.

◆ Dynamic Braking Options

Dynamic braking (DB) helps bring the motor to a smooth and rapid stop when working with high inertia loads. As the drive lowers the frequency of a motor moving a high inertia load, regeneration occurs. This can cause an overvoltage situation when the regenerative energy flows back into the DC bus capacitors. A braking resistor prevents these overvoltage faults.

NOTICE: Do not allow unqualified personnel to use the product. Failure to comply could result in damage to the drive or braking circuit. Carefully review the braking resistor instruction manual when connecting a braking resistor option to the drive.

- Note:**
1. Properly size the braking circuit to dissipate the power required to decelerate the load in the desired time. Ensure that the braking circuit can dissipate the energy for the set deceleration time prior to running the drive.
 2. Set L8-55 to 0 to disable the internal braking transistor of the drive protection when using braking resistor options.
 3. Set L3-04 to 0 to disable Stall Prevention during deceleration when using a regenerative converter, a regenerative unit, a braking resistor, or the Braking Resistor Unit. The default setting for the Stall Prevention function (enabled) will interfere with the braking resistor.

WARNING! Fire Hazard. The braking resistor connection terminals are B1 and B2. Do not connect a braking resistor directly to any other terminals. Improper wiring connections could result in death or serious injury by fire. Failure to comply may result in damage to the braking circuit or drive.

NOTICE: Connect braking resistors to the drive as shown in the I/O wiring examples. Improperly wiring braking circuits could result in damage to the drive or equipment.

■ Installing a Braking Resistor: ERF type

ERF type braking resistors provide dynamic braking capability with up to 3% ED. They can be directly connected to the B1 and B2 terminals of the drive as shown in [Figure 8.15](#).

Enable the drive braking resistor overload protection by setting L8-01 to 1 when using ERF type resistors.

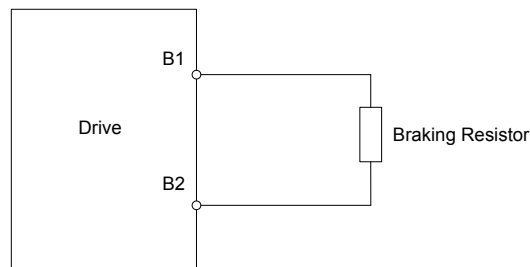

Figure 8.15 Connecting a Braking Resistor: ERF Type

■ Installing a Braking Resistor Unit: LKEB type

LKEB type braking resistors provide dynamic braking capability with up to 10% ED. They can be directly connected to the drives B1 and B2 terminals as shown in [Figure 8.16](#). The LKEB unit has a thermal overload contact that should be utilized in order to switch off the drive in case braking resistor overheat occurs.

The internal braking resistor overload protection of the drive cannot protect LKEB resistors. Set L8-01 to 0 to disable this function.

8.5 Installing Peripheral Devices

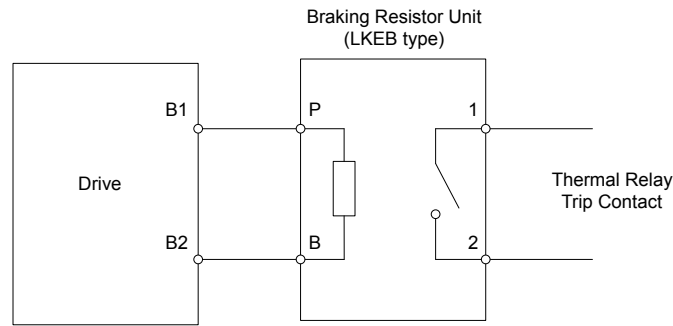

Figure 8.16 Connecting a Braking Resistor Unit: LKEB Type
(Models 2A0004 to 2A0138, 4A0002 to 4A0072, and 5A0003 to 5A0052)

■ Installing Other Types of Braking Resistors

When installing braking resistors other than the ERF or LKEB types, make sure that the drive internal braking transistor will not be overloaded with the required duty cycle and the selected resistance value. Use a resistor that is equipped with a thermal overload relay contact, and utilize this contact to switch off the drive in case of braking resistor overheating.

■ Braking Resistor Overload Protection

If using a braking resistor option, a sequence such as the one shown in [Figure 8.17](#) should be set up to interrupt the power supply in case the braking resistor overheats.

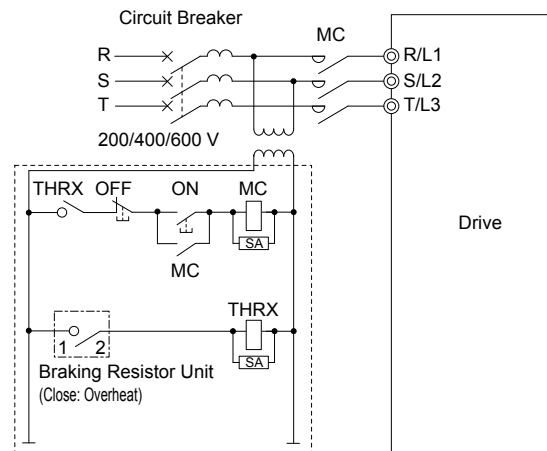

Figure 8.17 Power Supply Interrupt for Overheat Protection (Example)

■ Installing a Braking Unit: CDBR Type

To install a CDBR type braking unit, connect the +3 terminal of the drive to the positive terminal on the braking unit.

Next, wire together the negative terminals on the drive and braking unit. Terminal +2 is not used.

Connect the braking resistor to CDBR terminals +0 and -0.

Wire the thermal overload relay contact of the CDBR and the braking resistor in series, and connect this signal to a drive digital input. Use this input to trigger a fault in the drive in case a CDBR or braking resistor overload occurs.

Set L8-55 to 0 to disable dynamic braking transistor protection.

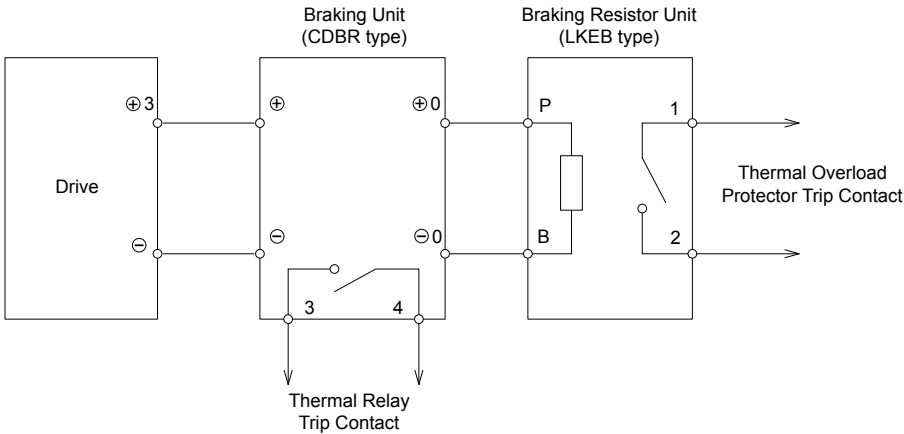

Figure 8.18 Connecting a Braking Unit (CDBR type) and Braking Resistor Unit (LKEB type) (Models 2A0169 to 2A0415 and 4A0088 to 4A1200)

Note: To install a CDBR type braking unit to the drive with a built-in dynamic braking transistor (models 2A0004 to 2A0138 and 4A0002 to 4A0072), connect the drive B1 terminal to the positive terminal on the braking unit. Next, wire the negative terminals on the drive and braking unit together. Terminal B2 is not used.

■ Using Braking Units in Parallel

When multiple braking units are used, they must be installed with a master-slave configuration with a single braking unit acting as the master. *Figure 8.19* illustrates how to wire braking units in parallel.

Wire the thermal overload contact relays of all CDBRs and all braking resistors in series, then connect this signal to a drive digital input. This input can be used to trigger a fault in the drive in case of overload in any of the CDBRs or braking resistors.

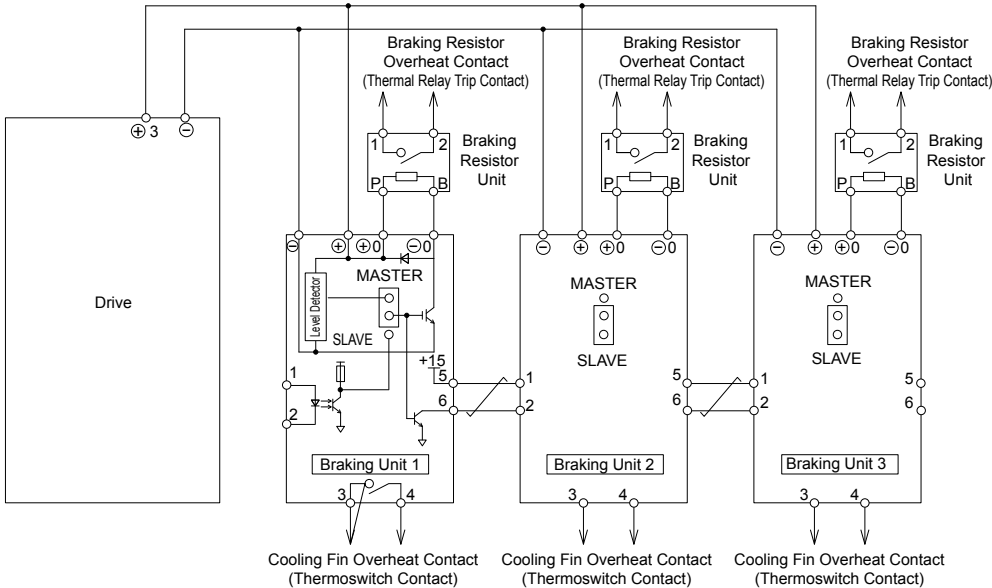

Figure 8.19 Connecting Braking Units in Parallel

◆ Installing a Molded Case Circuit Breaker (MCCB) or Ground Fault Circuit Interrupter (GFCI)

Install an MCCB or GFCI for line protection between the power supply and the main circuit power supply input terminals R/L1, S/L2, and T/L3. This protects the main circuit and devices wired to the main circuit while also providing overload protection.

NOTICE: Prevent Equipment Damage. Install a fuse and a GFCI to models 4A0930 and 4A1200, Failure to comply may result in damage to the power supply in the event of a short circuit.

Consider the following when selecting and installing an MCCB or GFCI:

- The capacity of the MCCB or GFCI should be 1.5 to 2 times the rated output current of the drive. Use an MCCB or GFCI to keep the drive from faulting out instead of using overheat protection (150% for one minute at the rated output current).
- If several drives are connected to one MCCB or GFCI that is shared with other equipment, use a sequence that shuts the power OFF when errors are output by using magnetic contactor (MC) as shown in [Figure 8.20](#).

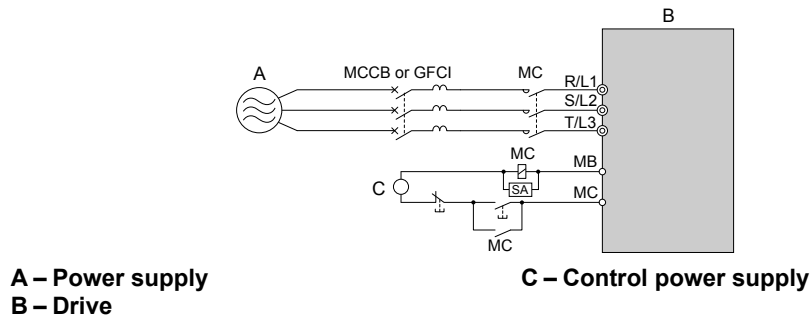

Figure 8.20 Power Supply Interrupt Wiring (Example)

WARNING! Electrical Shock Hazard. Disconnect the MCCB (or GFCI) and MC before wiring terminals. Failure to comply may result in serious injury or death.

■ Application Precautions when Installing a GFCI

Drive outputs generate high-frequency leakage current as a result of high-speed switching. Install a GFCI on the input side of the drive to switch off potentially harmful leakage current.

Factors in determining leakage current:

- Size of the AC drive
- AC drive carrier frequency
- Motor cable type and length
- EMI/RFI filter

If the GFCI trips spuriously, consider changing these items or use a GFCI with a higher trip level.

Note: Choose a GFCI designed specifically for an AC drive. The operation time should be at least 0.1 s with sensitivity amperage of at least 200 mA per drive. The output waveform of the drive and built-in EMC filter may cause an increase in leakage current. This may in turn cause the leakage breaker to malfunction. Increase the sensitivity amperage or lower the carrier frequency to correct the problem.

◆ Installing a Magnetic Contactor at the Power Supply Side

Install a magnetic contactor (MC) to the drive input for the purposes explained below.

■ Disconnecting the Power Supply

Shut off the drive with an MC when a fault occurs in any external equipment such as braking resistors.

NOTICE: Do not connect electromagnetic switches or MCs to the output motor circuits without proper sequencing. Improper sequencing of output motor circuits could result in damage to the drive.

NOTICE: Install an MC on the input side of the drive when the drive should not automatically restart after power loss. To get the full performance life out of the electrolytic capacitors and circuit relays, refrain from switching the drive power supply off and on more than once every 30 minutes. Frequent use can damage the drive. Use the drive to stop and start the motor.

NOTICE: Use a magnetic contactor (MC) to ensure that power to the drive can be completely shut off when necessary. The MC should be wired so that it opens when a fault output terminal is triggered.

- Note:**
1. Install an MC to the drive input side to prevent the drive from restarting automatically when power is restored after momentary power loss.
 2. Set up a delay that prevents the MC from opening prematurely to continue operating the drive through a momentary power loss.

■ Protecting the Braking Resistor or Braking Resistor Unit

Use an MC on the input side of the drive to protect a braking resistor or braking resistor unit from overheat or fire.

WARNING! Fire Hazard. When using a braking unit, use a thermal relay on the braking resistors and configure a fault contact output for the braking resistor unit to disconnect drive main power via an input contactor. Inadequate braking circuit protection could result in death or serious injury by fire from overheating resistors.

◆ Connecting an AC Reactor or DC Link Choke

AC reactors and DC link chokes suppress surges in current and improve the power factor on the input side of the drive.

Use an AC reactor, a DC link choke, or both in the following situations:

- To suppress harmonic current or improve the power factor of the power supply.
- When using a phase advancing capacitor switch.
- With a large capacity power supply transformer (over 600 kVA).

Note: Use an AC reactor or DC link choke when also connecting a thyristor converter (such as a DC drive) to the same power supply system, regardless of the conditions of the power supply.

■ Connecting an AC Reactor

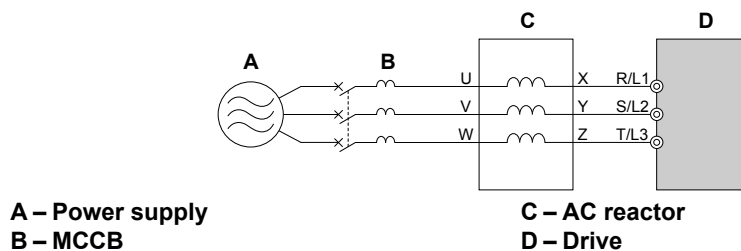

Figure 8.21 Connecting an AC Reactor

■ Connecting a DC Link Choke

A DC link choke can be installed to drive models 2A0004 to 2A0081, 4A0002 to 4A0044, and 5A0003 to 5A0032. When installing a DC link choke, remove the jumper between terminals +1 and +2 (terminals are jumpered for shipment). The jumper must be installed if not using a DC link choke. Refer to [Figure 8.22](#) for an example of DC link choke wiring.

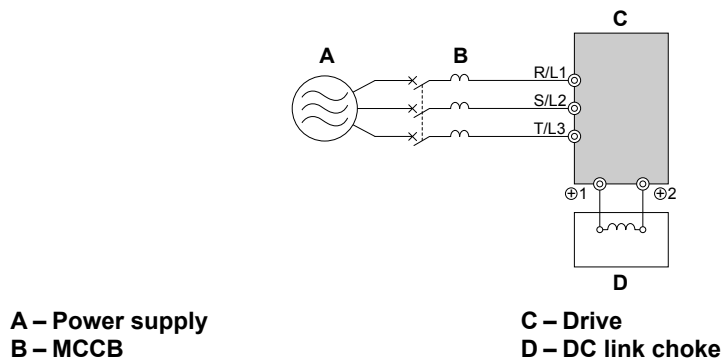

Figure 8.22 Connecting a DC Link Choke

◆ Connecting a Surge Absorber

A surge absorber suppresses surge voltage generated from switching an inductive load near the drive. Inductive loads include magnetic contactors, relays, valves, solenoids, and brakes. Always use a surge absorber or diode when operating with an inductive load.

WARNING! Fire Hazard. Due to surge absorber short circuit on drive output terminals U/T1, V/T2, and W/T3, do not connect surge absorbers to the drive output power terminals. Failure to comply may result in serious injury or death by fire or flying debris.

◆ Connecting a Noise Filter

■ Input-Side Noise Filter

Drive outputs generate noise as a result of high-speed switching. This noise flows from inside the drive back to the power supply, possibly affecting other equipment. Installing a noise filter to the input side of the drive can reduce the amount of noise flowing back into the power supply. This also prevents noise from entering the drive from the power supply.

- Use a noise filter specifically designed for AC drives.
- Install the noise filter as close as possible to the drive.

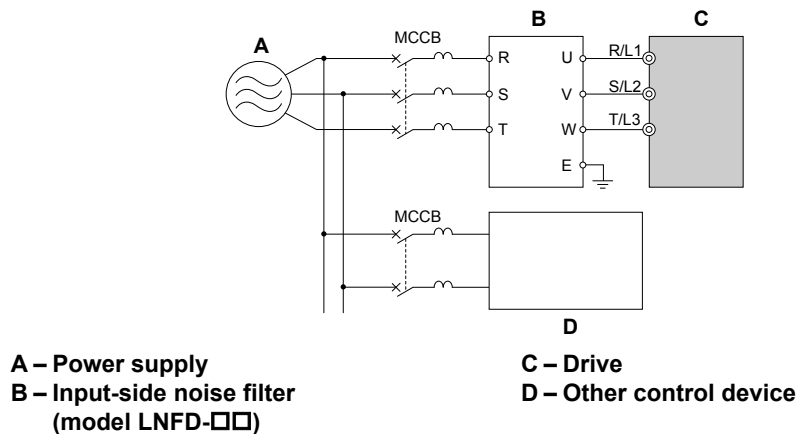

Figure 8.23 Input-Side Noise Filter (Three-Phase 200/400 V)

■ Output-Side Noise Filter

A noise filter on the output side of the drive reduces inductive noise and radiated noise. [Figure 8.24](#) illustrates an example of output-side noise filter wiring.

NOTICE: Do not connect phase-advancing capacitors or LC/RC noise filters to the output circuits. Improper application of noise filters could result in damage to the drive.

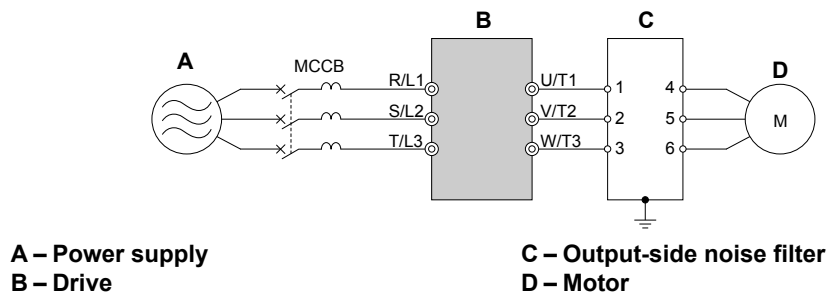

Figure 8.24 Output-Side Noise Filter

- **Radiated Noise:** Electromagnetic waves radiated from the drive and cables create noise throughout the radio bandwidth that can affect surrounding devices.
- **Induced Noise:** Noise generated by electromagnetic induction can affect the signal line and may cause the controller to malfunction.

Preventing Induced Noise

Use a noise filter on the output side or use shielded cables. Lay the cables at least 30 cm away from the signal line to prevent induced noise.

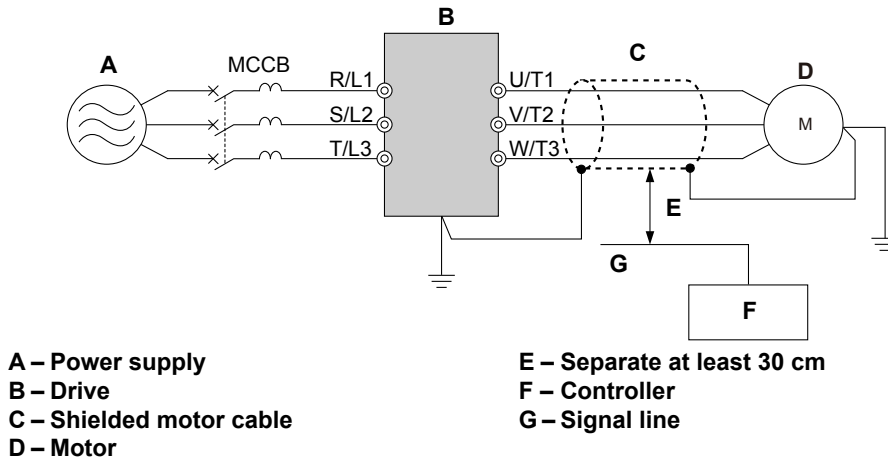

Figure 8.25 Preventing Induced Noise

Reducing Radiated and Radio Frequency Noise

The drive, input lines, and output lines generate radio frequency noise. Use noise filters on input and output sides and install the drive in a metal enclosure panel to reduce radio frequency noise.

Note: The cable running between the drive and motor should be as short as possible.

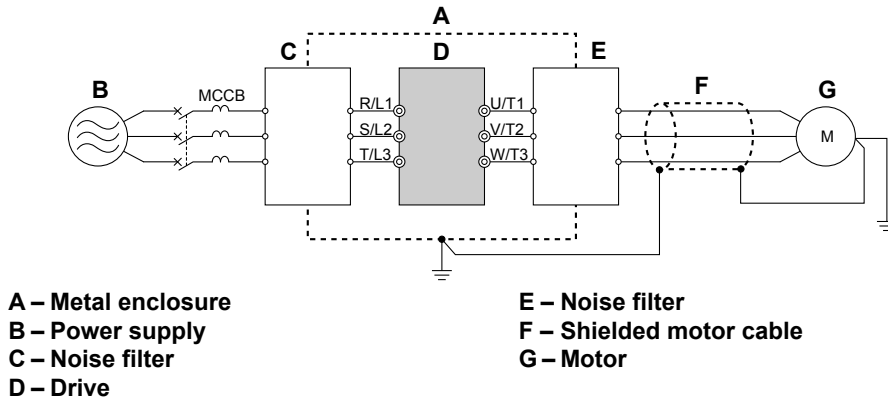

Figure 8.26 Reducing Radio Frequency Noise

◆ **Installing Input Fuses**

NOTICE: If a fuse is blown or a Ground Fault Circuit Interrupter (GFCI) is tripped, check the wiring and the selection of the peripheral devices. Check the wiring and the selection of peripheral devices to identify the cause. Contact Yaskawa before restarting the drive or the peripheral devices if the cause cannot be identified

■ **Factory Recommended Branch Circuit Protection**

Yaskawa recommends installing one of the following types of branch circuit protection to maintain compliance with UL508C. Semiconductor protective type fuses are preferred. Alternate branch circuit protection devices are also listed in [Table 8.12](#) and [Table 8.13](#).

Table 8.12 Factory Recommended A1000 AC Drive Branch Circuit Protection (Normal Duty)

Drive Model	A1000 in Normal Duty Mode (C6-01 = 1)					
	Nominal Output Power HP	AC Drive Input Amps	MCCB Rating Amps <1>	Time Delay Fuse Rating Amps <2>	Non-time Delay Fuse Rating Amps <3>	Bussman Semiconductor Fuse Rating (Fuse Ampere) <4>
200 V Class						
2A0004	0.75	3.9	15	6.25	10	FWH-70B (70)
2A0006	1 - 1.5	7.3	15	12	20	FWH-70B (70)
2A0008	2	8.8	15	15	25	FWH-70B (70)
2A0010	3	10.8	20	17.5	30	FWH-70B (70)

8.5 Installing Peripheral Devices

Drive Model	A1000 in Normal Duty Mode (C6-01 = 1)					
	Nominal Output Power HP	AC Drive Input Amps	MCCB Rating Amps <1>	Time Delay Fuse Rating Amps <2>	Non-time Delay Fuse Rating Amps <3>	Bussman Semiconductor Fuse Rating (Fuse Ampere) <4>
2A0012	3	13.9	25	20	40	FWH-70B (70)
2A0018	5	18.5	35	30	50	FWH-90B(90)
2A0021	7.5	24	45	40	70	FWH-90B(90)
2A0030	10	37	60	60	110	FWH-100B (100)
2A0040	15	52	100	90	150	FWH-200B (200)
2A0056	20	68	125	110	200	FWH-200B (200)
2A0069	25	80	150	125	225	FWH-200B (200)
2A0081	30	96	175	150	275	FWH-300A (300)
2A0110	40	111	200	175	300	FWH-300A (300)
2A0138	50	136	250	225	400	FWH-350A (350)
2A0169	60	164	300	250	450	FWH-400A (400)
2A0211	75	200	400	350	600	FWH-400A (400)
2A0250	100	271	500	450	800	FWH-600A (600)
2A0312	125	324	600	500	800	FWH-700A (700)
2A0360	150	394	700	600	1000 <5>	FWH-800A (800)
2A0415	175	471	900	800	1400 <5>	FWH-1000A (1000)
400 V Class						
4A0002	1	2.1	15	3.5	6	FWH-40B (40)
4A0004	2	4.3	15	7.5	12	FWH-50B (50)
4A0005	3	5.9	15	10	17.5	FWH-70B (70)
4A0007	3	8.1	15	12	20	FWH-70B (70)
4A0009	5	9.4	15	15	25	FWH-90B (90)
4A0011	7.5	14	25	20	40	FWH-90B (90)
4A0018	10	20	40	35	60	FWH-80B (80)
4A0023	15	24	45	40	70	FWH-100B (100)
4A0031	20	38	75	60	110	FWH-125B (125)
4A0038	25	44	75	75	125	FWH-200B (200)
4A0044	30	52	100	90	150	FWH-250A (250)
4A0058	40	58	100	100	150	FWH-250A (250)
4A0072	50	71	125	110	200	FWH-250A (250)
4A0088	60	86	150	150	250	FWH-250A (250)
4A0103	75	105	200	175	300	FWH-250A (250)
4A0139	100	142	250	225	400	FWH-350A (350)
4A0165	125	170	300	250	500	FWH-400A (400)
4A0208	150	207	400	350	600	FWH-500A (500)
4A0250	200	248	450	400	700	FWH-600A (600)
4A0296	250	300	600	500	800	FWH-700A (700)
4A0362	300	346	600	600	1000 <5>	FWH-800A (800)
4A0414	350	410	800	700	1200 <5>	FWH-800A (800)
4A0515	400 - 450	465	900	800	1350 <5>	FWH-1000A (1000)
4A0675	500 - 600	657	1200	1100 <5>	1800 <5>	FWH-1200A (1200)
4A0930	700 - 800	922	Not Applicable			FWH-1200A (1200)
4A1200	900 - 1000	1158				FWH-1600A (1600)
600 V Class						
5A0003	2	3.6	15	6.25	10	FWP-50B (50)
5A0004	3	5.1	15	8	15	FWP-50B (50)

Drive Model	A1000 in Normal Duty Mode (C6-01 = 1)					
	Nominal Output Power HP	AC Drive Input Amps	MCCB Rating Amps <1>	Time Delay Fuse Rating Amps <2>	Non-time Delay Fuse Rating Amps <3>	Bussman Semiconductor Fuse Rating (Fuse Ampere) <4>
5A0006	5	8.3	15	12	20	FWP-60B (60)
5A0009	7.5	12	20	20	35	FWP-60B (60)
5A0011	10	16	30	25	45	FWP-70B (70)
5A0017	15	23	40	40	60	FWP-100B (100)
5A0022	20	31	60	50	90	FWP-100B (100)
5A0027	25	38	75	60	110	FWP-125A (125)
5A0032	30	45	75	75	125	FWP-125A (125)
5A0041	40	44	75	75	125	FWP-175A (175)
5A0052	50	54	100	90	150	FWP-175A (175)
5A0062	60	66	125	110	175	FWP-250A (250)
5A0077	75	80	150	125	225	FWP-250A (250)
5A0099	100	108	175	175	300	FWP-250A (250)
5A0125	125	129	225	225	350	FWP-350A (350)
5A0145	150	158	300	275	450	FWP-350A (350)
5A0192	200	228	400	350	600	FWP-600A (600)
5A0242	250	263	500	450	700	FWP-600A (600)

- <1> Maximum MCCB Rating is 15 A, or 200 % of drive input current rating, whichever is larger. MCCB voltage rating must be 600 VAC or greater.
- <2> Maximum Time Delay fuse is 175% of drive input current rating. This covers any Class CC, J or T class fuse.
- <3> Maximum Non-time Delay fuse is 300% of drive input current rating. This covers any CC, J or T class fuse.
- <4> When using semiconductor fuses, Bussman FWH and FWP are required for UL compliance. Select FWH for 200 V Class and 400 V Class models and FWP fuses for 600 V models.
- <5> Class L fuse is also approved for this rating.

Table 8.13 Factory Recommended A1000 AC Drive Branch Circuit Protection (Heavy Duty)

Drive Model	A1000 in Heavy Duty Mode (C6-01 = 0)					
	Nominal Output Power HP	AC Drive Input Amps	MCCB Rating Amps <1>	Time Delay Fuse Rating Amps <2>	Non-time Delay Fuse Rating Amps <3>	Bussman Semiconductor Fuse Rating (Fuse Ampere) <4>
200 V Class						
2A0004	0.75	2.9	15	5	8	FWH-70B (70)
2A0006	1	5.8	15	10	15	FWH-70B (70)
2A0008	2	7	15	12	17.5	FWH-70B (70)
2A0010	2	7.5	15	12	20	FWH-70B (70)
2A0012	3	11	20	17.5	30	FWH-70B (70)
2A0018	3	15.6	25	25	40	FWH-90B(90)
2A0021	5	18.9	35	30	50	FWH-90B(90)
2A0030	7.5	28	50	40	75	FWH-100B (100)
2A0040	10	37	60	60	100	FWH-200B (200)
2A0056	15	52	100	90	150	FWH-200B (200)
2A0069	20	68	125	110	200	FWH-200B (200)
2A0081	25	80	150	125	225	FWH-300A (300)
2A0110	30	82	150	125	225	FWH-300A (300)
2A0138	40	111	200	175	250	FWH-350A (350)
2A0169	50	136	250	225	350	FWH-400A (400)
2A0211	60	164	300	250	450	FWH-400A (400)
2A0250	75	200	400	350	600	FWH-600A (600)
2A0312	100	271	500	450	800	FWH-700A (700)

8.5 Installing Peripheral Devices

Drive Model	A1000 in Heavy Duty Mode (C6-01 = 0)					
	Nominal Output Power HP	AC Drive Input Amps	MCCB Rating Amps <1>	Time Delay Fuse Rating Amps <2>	Non-time Delay Fuse Rating Amps <3>	Bussman Semiconductor Fuse Rating (Fuse Ampere) <4>
2A0360	125	324	600	500	900 <4>	FWH-800A (800)
2A0415	150	394	700	600	1100 <4>	FWH-1000A (1000)
400 V Class						
4A0002	0.75	1.8	15	3	5	FWH-40B (40)
4A0004	1 - 2	3.2	15	5	9	FWH-50B (50)
4A0005	3	4.4	15	7	12	FWH-70B (70)
4A0007	3	6	15	10	17.5	FWH-70B (70)
4A0009	5	8.2	15	12	20	FWH-90B (90)
4A0011	5	10.4	20	17.5	30	FWH-90B (90)
4A0018	7.5 - 10	15	30	25	40	FWH-80B (80)
4A0023	10	20	40	35	60	FWH-100B (100)
4A0031	15	29	50	50	80	FWH-125B (125)
4A0038	20	39	75	60	110	FWH-200B (200)
4A0044	25 - 30	47	75	75	125	FWH-250A (250)
4A0058	30	43	75	75	125	FWH-250A (250)
4A0072	40	58	100	100	150	FWH-250A (250)
4A0088	60	71	125	110	200	FWH-250A (250)
4A0103	60	86	150	150	250	FWH-250A (250)
4A0139	75	105	175	175	300	FWH-350A (350)
4A0165	100	142	225	225	400	FWH-400A (400)
4A0208	125 - 150	170	250	250	500	FWH-500A (500)
4A0250	150	207	350	350	600	FWH-600A (600)
4A0296	200	248	400	400	700	FWH-700A (700)
4A0362	250	300	500	500	800	FWH-800A (800)
4A0414	300	346	600	600	1000 <4>	FWH-800A (800)
4A0515	350	410	700	700	1200 <4>	FWH-1000A (1000)
4A0675	400 - 500	584	1000	1000 <4>	1600 <4>	FWH-1200A (1200)
4A0930	600 - 700	830	Not Applicable			FWH-1200A (1200)
4A1200	800 - 900	1031	Not Applicable			FWH-1600A (1600)
600 V Class						
5A0003	1	1.9	15	3	5	FWP-50B (50)
5A0004	2	3.6	15	6.25	10	FWP-50B (50)
5A0006	3	5.1	15	8	15	FWP-60B (60)
5A0009	5	8.3	15	12	20	FWP-60B (60)
5A0011	7.5	12	20	20	35	FWP-70B (70)
5A0017	10	16	30	25	45	FWP-100B (100)
5A0022	15	23	40	40	60	FWP-100B (100)
5A0027	20	31	60	50	90	FWP-125A (125)
5A0032	25	38	75	60	100	FWP-125A (125)
5A0041	30	33	60	50	90	FWP-175A (175)
5A0052	40	44	75	75	125	FWP-175A (175)
5A0062	50	54	100	90	150	FWP-250A (250)
5A0077	60	66	125	110	175	FWP-250A (250)
5A0099	75	80	150	125	225	FWP-250A (250)
5A0125	100	108	175	175	300	FWP-350A (350)
5A0145	125	129	250	225	350	FWP-350A (350)

Drive Model	A1000 in Heavy Duty Mode (C6-01 = 0)					
	Nominal Output Power HP	AC Drive Input Amps	MCCB Rating Amps <1>	Time Delay Fuse Rating Amps <2>	Non-time Delay Fuse Rating Amps <3>	Bussman Semiconductor Fuse Rating (Fuse Ampere) <4>
5A0192	150	158	300	250	400	FWP-600A (600)
5A0242	200	228	400	350	600	FWP-600A (600)

- <1> Maximum MCCB Rating is 15 A, or 200 % of drive input current rating, whichever is larger. MCCB voltage rating must be 600 VAC or greater.
- <2> Maximum Time Delay fuse is 175% of drive input current rating. This covers any Class CC, J or T class fuse.
- <3> Maximum Non-time Delay fuse is 300% of drive input current rating. This covers any CC, J or T class fuse.
- <4> Class L fuse is also approved for this rating.

Wiring Fuses for Models 4A0930 and 4A1200

NOTICE: If a fuse is blown or an Ground Fault Circuit Interrupter (GFCI) is tripped, check the wiring and the selection of peripheral devices to identify the cause. Contact Yaskawa before restarting the drive or the peripheral devices if the cause cannot be identified.

Install a fuse on the input side to protect drive wiring and prevent other secondary damage. Wire the fuse so that leakage current in the upper controller power supply will trigger the fuse and shut off the power supply.

Select the appropriate fuse from [Table 3.2](#).

Table 8.14 Input Fuses for Models 4A0930 and 4A1200

Voltage Class	Model	Selection			Input Fuse (Example)			
		Input Voltage	Current	Pre-arc I ² t (A ² s)	Model	Manufacturer	Rating	Pre-arc I ² t (A ² s)
Three-Phase 400 V Class	4A0930	480 V	1500 A	140000 to 3100000	CS5F-1200	Fuji Electric	AC500 V, 1200 A	276000
					FWH-1200A	Bussman	AC500 V, 1200 A	–
	4A1200	480 V	1500 A	320000 to 3100000	CS5F-1500	Fuji Electric	AC500 V, 1500 A	351000
					FWH-1600A	Bussman	AC500 V, 1600 A	–

◆ **Attachment for External Heatsink Mounting**

An external attachment can be used to project the heatsink outside of an enclosure to ensure that there is sufficient air circulation around the heatsink.

Contact a Yaskawa sales representative or Yaskawa directly for more information on this attachment.

◆ **Installing a Motor Thermal Overload (oL) Relay on the Drive Output**

Motor thermal overload relays protect the motor by disconnecting power lines to the motor due to a motor overload condition. Install a motor thermal overload relay between the drive and motor:

- When operating multiple motors on a single AC drive.
- When using a power line bypass to operate the motor directly from the power line.

It is not necessary to install a motor thermal overload relay when operating a single motor from a single AC drive. The AC drive has UL recognized electronic motor overload protection built into the drive software.

- Note:**
1. Disable the motor protection function (L1-01 = 0) when using an external motor thermal overload relay.
 2. The relay should shut off main power on the input side of the main circuit when triggered.

■ **General Precautions when Using Thermal Overload Relays**

Consider the following application precautions when using motor thermal overload relays on the output of AC drives to prevent nuisance trips or overheat of the motor at low speeds:

1. Low speed motor operation
2. Use of multiple motors on a single AC drive
3. Motor cable length
4. Nuisance tripping resulting from high AC drive carrier frequency.

Low Speed Operation and Motor Thermal oL Relays

Generally, thermal relays are applied on general-purpose motors. When general-purpose motors are driven by AC drives, the motor current is approximately 5% to 10% greater than if driven by a commercial power supply. In addition, the cooling capacity of a motor with a shaft-driven fan decreases when operating at low speeds. Motor overheating may occur even when

8.5 Installing Peripheral Devices

the load current is within the motor rated value. A thermal relay cannot effectively protect the motor due to the reduction of cooling at low speeds. For this reason, apply the UL recognized electronic thermal overload protection function built into the drive whenever possible.

UL recognized electronic thermal overload function of the drive: Speed-dependent heat characteristics are simulated using data from standard motors and force-ventilated motors. The motor is protected from overload using this function.

Using a Single Drive to Operate Multiple Motors

Set parameter L1-01 to 0 to disable thermal overload protection for the drive.

Note: The UL recognized electronic thermal overload function cannot be applied when operating multiple motors with a single drive.

Long Motor Cables

When a high carrier frequency and long motor cables are used, nuisance tripping of the thermal relay may occur due to increased leakage current. To avoid this, reduce the carrier frequency or increase the tripping level of the thermal overload relay.

Nuisance Tripping Due to a High AC Drive Carrier Frequency

Current waveforms generated by high carrier frequency PWM drives tend to increase the temperature in overload relays. It may be necessary to increase the trip level setting when encountering nuisance triggering of the relay.

WARNING! Fire Hazard. *Confirm an actual motor overload condition is not present prior to increasing the thermal oL trip setting. Check local electrical codes before making adjustments to motor thermal overload settings. Failure to comply could result in death or serious injury.*

Appendix: A

Specifications

A.1	HEAVY DUTY AND NORMAL DUTY RATINGS.....	462
A.2	POWER RATINGS.....	463
A.3	DRIVE SPECIFICATIONS.....	472
A.4	DRIVE WATT LOSS DATA.....	474
A.5	DRIVE DERATING DATA.....	476

A.1 Heavy Duty and Normal Duty Ratings

The capacity of the drive is based on two types of load characteristics: Heavy Duty (HD) and Normal Duty (ND). Refer to the following table for the differences between HD and ND.

Table A.1 Selecting the Appropriate Load Rating

Setting Parameter C6-01	Rated Output Current	Overload Tolerance	Default Carrier Frequency
0: Heavy Duty	HD Rating varies by model </>	150% rated output current for 60 s	2 kHz
1: Normal Duty (default)	ND Rating varies by model </>	120% rated output current for 60 s varies by model	2 kHz, Swing PWM

<1> *Refer to Power Ratings on page 463* for information on rating changes based on drive model.



- **HD and ND:** HD refers to applications requiring constant torque output, while ND refers to applications with variable torque needs. The drive allows the user to select HD or ND torque depending on the application. Fans, pumps, and blowers should use ND (C6-01 = 1), and other applications generally use HD (C6-01 = 0).
- **Swing PWM:** Swing PWM equivalent to a 2 kHz audible noise. This function turns the motor noise into a less obtrusive white noise.

Note: Differences between HD ratings and ND ratings for the drive include rated input and output current, overload capacity, carrier frequency, and current limit. The default setting is for ND (C6-01 = 1).

A.2 Power Ratings

◆ Three-Phase 200 V Class Drive Models 2A0004 to 2A0030

Table A.2 Power Ratings (Three-Phase 200 V Class)

Item		Specification							
Drive Model		2A0004	2A0006	2A0008	2A0010	2A0012	2A0018	2A0021	2A0030
Maximum Applicable Motor Capacity (HP) <1>	ND Rating	0.75	1	2	3	3	5	7.5	10
	HD Rating	0.75	1	2	2	3	3	5	7.5
Input Current (A) <2>	ND Rating	3.9	7.3	8.8	10.8	13.9	18.5	24	37
	HD Rating	2.9	5.8	7	7.5	11	15.6	18.9	28
Input	Rated Voltage Rated Frequency	Three-phase 200 to 240 Vac 50/60 Hz/270 to 340 Vdc <3>							
	Allowable Voltage Fluctuation	-15 to 10%							
	Allowable Frequency Fluctuation	±5%							
	Input Power (kVA)	ND Rating	2.2	3.1	4.1	5.8	7.8	9.5	14
HD Rating		1.3	2.2	3.1	4.1	5.8	7.8	9.5	14
Rated Output Capacity (kVA) <4>	ND Rating <5>	1.3	2.3	3	3.7	4.6	6.7	8	11.4
	HD Rating <6>	1.2	1.9	2.6	3	4.2	5.3	6.7	9.5
Rated Output Current (A)	ND Rating <5>	3.5	6	8	9.6	12	17.5	21	30
	HD Rating <6>	3.2	5	6.9	8	11	14	17.5	25
Output	Overload Tolerance	ND Rating: 120% of rated output current for 60 s HD Rating: 150% of rated output current for 60 s (Derating may be required for applications that start and stop frequently)							
	Carrier Frequency	User adjustable between 1 and 15 kHz							
	Maximum Output Voltage (V)	Three-phase 200 to 240 V (proportional to input voltage)							
	Maximum Output Frequency (Hz)	400 Hz (user-set)							

<1> The motor capacity (HP) refers to a NEC rated 4-pole motor. The rated output current of the drive output amps should be equal to or greater than the motor current. Select the appropriate capacity drive if operating the motor continuously above motor nameplate current.

<2> Assumes operation at the rated output current. Input current rating varies depending on the power supply transformer, input reactor, wiring connections, and power supply impedance.

<3> DC is not available for UL/CE standards.

<4> Rated motor capacity is calculated with a rated output voltage of 220 V.

<5> Carrier frequency is set to 2 kHz. Current derating is required in order to raise the carrier frequency.

<6> Carrier frequency can be increased to 8 kHz while keeping this current derating. Higher carrier frequency settings require derating..

◆ Three-Phase 200 V Class Drive Models 2A0040 to 2A0211

Table A.3 Power Ratings Continued (Three-Phase 200 V Class)

Item		Specification							
Drive Model		2A0040	2A0056	2A0069	2A0081	2A0110	2A0138	2A0169	2A0211
Maximum Applicable Motor Capacity (HP) <1>	ND Rating	15	20	25	30	40	50	60	75
	HD Rating	10	15	20	25	30	40	50	60
Input Current (A) <2>	ND Rating	52	68	80	96	111	136	164	200
	HD Rating	37	52	68	80	82	111	136	164
Input	Rated Voltage Rated Frequency	Three-phase 200 to 240 Vac 50/60 Hz/270 to 340 Vdc <3>							
	Allowable Voltage Fluctuation	-15 to 10%							
	Allowable Frequency Fluctuation	±5%							
	Input Power (kVA)	ND Rating	27	36	44	52	51	62	75
HD Rating		18	27	36	44	37	51	62	75
Rated Output Capacity (kVA) <4>	ND Rating <5>	15.2	21	26	31	42	53	64	80
	HD Rating	12.6 <6>	17.9 <6>	23 <6>	29 <6>	32 <6>	44 <6>	55 <6>	69 <7>
Rated Output Current (A)	ND Rating <5>	40	56	69	81	110	138	169	211
	HD Rating	33 <6>	47 <6>	60 <6>	75 <6>	85 <6>	115 <6>	145 <6>	180 <7>
Output	Overload Tolerance	ND Rating: 120% of rated output current for 60 s HD Rating: 150% of rated output current for 60 s (Derating may be required for applications that start and stop frequently)							
	Carrier Frequency	User adjustable between 1 and 15 kHz						User adjustable between 1 and 10 kHz	
	Maximum Output Voltage (V)	Three-phase 200 to 240 V (proportional to input voltage)							
	Maximum Output Frequency (Hz)	400 Hz (user-set)							

- <1> The motor capacity (HP) refers to a NEC rated 4-pole motor. The rated output current of the drive output amps should be equal to or greater than the motor current. Select the appropriate capacity drive if operating the motor continuously above motor nameplate current.
- <2> Assumes operation at the rated output current. Input current rating varies depending on the power supply transformer, input reactor, wiring connections, and power supply impedance.
- <3> DC is not available for UL/CE standards.
- <4> Rated motor capacity is calculated with a rated output voltage of 220 V.
- <5> Carrier frequency is set to 2 kHz. Current derating is required in order to raise the carrier frequency.
- <6> Carrier frequency can be increased to 8 kHz while keeping this current derating. Higher carrier frequency settings require derating.
- <7> Carrier frequency can be increased to 5 kHz while keeping this current derating. Higher carrier frequency settings require derating.

◆ Three-Phase 200 V Class Drive Models 2A0250 to 2A0415

Table A.4 Power Ratings Continued (Three-Phase 200 V Class)

Item		Specification				
Drive Models		2A0250	2A0312	2A0360	2A0415	
Maximum Applicable Motor Capacity (HP) <1>	ND Rating	100	125	150	175	
	HD Rating	75	100	125	150	
Input Current (A) <2>	ND Rating	271	324	394	471	
	HD Rating	200	271	324	394	
Input	Rated Voltage Rated Frequency	Three-phase 200 to 240 Vac 50/60 Hz/270 to 340 Vdc <3>				
	Allowable Voltage Fluctuation	-15 to 10%				
	Allowable Frequency Fluctuation	±5%				
	Input Power (kVA)	ND Rating	124	148	180	215
HD Rating		91	124	148	180	
Output	Rated Output Capacity (kVA) <4>	ND Rating <5>	95	119	137	158
		HD Rating	82 <6>	108 <6>	132 <6>	158 <5>
	Rated Output Current (A)	ND Rating <5>	250	312	360	415
		HD Rating	215 <6>	283 <6>	346 <6>	415 <5>
	Overload Tolerance	ND Rating: 120% of rated output current for 60 s HD Rating: 150% of rated output current for 60 s (Derating may be required for applications that start and stop frequently)				
	Carrier Frequency	User adjustable between 1 and 10 kHz				
	Maximum Output Voltage (V)	Three-phase 200 to 240 V (proportional to input voltage)				
	Maximum Output Frequency (Hz)	400 Hz (user-set)				

<1> The motor capacity (HP) refers to a NEC rated 4-pole motor. The rated output current of the drive output amps should be equal to or greater than the motor current. Select the appropriate capacity drive if operating the motor continuously above motor nameplate current.

<2> Assumes operation at the rated output current. Input current rating varies depending on the power supply transformer, input reactor, wiring connections, and power supply impedance.

<3> DC is not available for UL/CE standards.

<4> Rated motor capacity is calculated with a rated output voltage of 220 V.

<5> Carrier frequency is set to 2 kHz. Current derating is required in order to raise the carrier frequency.

<6> Carrier frequency can be increased to 5 kHz while keeping this current derating. Higher carrier frequency settings require derating.

◆ Three-Phase 400 V Class Drive Models 4A0002 to 4A0031

Table A.5 Power Ratings (Three-Phase 400 V Class)

Item		Specification									
Drive Models		4A0002	4A0004	4A0005	4A0007	4A0009	4A0011	4A0018	4A0023	4A0031	
Maximum Applicable Motor Capacity (HP) <1>	ND Rating	0.75	2	3	3	5	7.5	10	15	20	
	HD Rating	0.75	2	3	3	5	5	7.5	10	15	
Input	Input Current (A) <2>	ND Rating	2.1	4.3	5.9	8.1	9.4	14	20	24	38
		HD Rating	1.8	3.2	4.4	6	8.2	10.4	15	20	29
	Rated Voltage Rated Frequency		Three-phase: 380 to 480 Vac 50/60 Hz/510 to 680 Vdc <3>								
	Allowable Voltage Fluctuation		-15 to 10%								
	Allowable Frequency Fluctuation		±5%								
	Input Power (kVA)	ND Rating	2.3	4.3	6.1	8.1	10.0	14.5	19.4	28.4	37.5
HD Rating		1.4	2.3	4.3	6.1	8.1	10.0	14.6	19.2	28.4	
Output	Rated Output Capacity (kVA) <4>	ND Rating <5>	1.6	3.1	4.1	5.3	6.7	8.5	13.3	17.5	24
		HD Rating	1.4	2.6	3.7	4.2	5.5	7	11.3	13.7	18.3
	Rated Output Current (A)	ND Rating <5>	2.1	4.1	5.4	6.9	8.8	11.1	17.5	23	31
		HD Rating <6>	1.8	3.4	4.8	5.5	7.2	9.2	14.8	18	24
	Overload Tolerance		ND Rating: 120% of rated output current for 60 s HD Rating: 150% of rated output current for 60 s (Derating may be required for applications that start and stop frequently)								
	Carrier Frequency		User adjustable between 1 and 15 kHz								
	Maximum Output Voltage (V)		Three-phase: 380 to 480 V (proportional to input voltage)								
Maximum Output Frequency (Hz)		400 Hz (user-adjustable)									

- <1> The motor capacity (HP) refers to a NEC rated 4-pole motor. The rated output current of the drive output amps should be equal to or greater than the motor current. Select the appropriate capacity drive if operating the motor continuously above motor nameplate current.
- <2> Assumes operation at the rated output current. Input current rating varies depending on the power supply transformer, input reactor, wiring conditions, and power supply impedance.
- <3> DC is not available for UL/CE standards.
- <4> Rated motor capacity is calculated with a rated output voltage of 440 V.
- <5> Carrier frequency is set to 2 kHz. Current derating is required in order to raise the carrier frequency.
- <6> Carrier frequency can be increased to 8 kHz while keeping this current derating. Higher carrier frequency settings require derating.

◆ Three-Phase 400 V Class Drive Models 4A0038 to 4A0165

Table A.6 Power Ratings Continued (Three-Phase 400 V Class)

Item		Specification								
Drive Models		4A0038	4A0044	4A0058	4A0072	4A0088	4A0103	4A0139	4A0165	
Maximum Applicable Motor Capacity (HP) <1>	ND Rating	25	30	40	50	60	75	100	125	
	HD Rating	20	25-30	25-30	40	50-60	50-60	75	100	
Input Current (A) <2>	ND Rating	44	52	58	71	86	105	142	170	
	HD Rating	39	44	43	58	71	86	105	142	
Input	Rated Voltage Rated Frequency	Three-phase: 380 to 480 Vac 50/60 Hz/510 to 680 Vdc <3>								
	Allowable Voltage Fluctuation	-15 to 10%								
	Allowable Frequency Fluctuation	±5%								
	Input Power (kVA)	ND Rating	46.6	54.9	53.0	64.9	78.6	96.0	130	156
	HD Rating	37.5	46.6	39.3	53.0	64.9	78.6	96.0	130	
Output	Rated Output Capacity (kVA) <4>	ND Rating <5>	29	34	44	55	67	78	106	126
		HD Rating	24	30	34	48	57	69	85 <7>	114 <7>
	Rated Output Current (A)	ND Rating <5>	38	44	58	72	88	103	139	165
		HD Rating	31 <6>	39 <6>	45 <6>	60 <6>	75 <6>	91 <6>	112 <7>	150 <7>
	Overload Tolerance	ND Rating: 120% of rated output current for 60 s HD Rating: 150% of rated output current for 60 s (Derating may be required for applications that start and stop frequently)								
	Carrier Frequency	User adjustable between 1 and 15 kHz						User adjustable between 1 and 10 kHz		
	Maximum Output Voltage (V)	Three-phase: 380 to 480 V (proportional to input voltage)								
	Maximum Output Frequency (Hz)	400 Hz (user-adjustable)								

- <1> The motor capacity (HP) refers to a NEC rated 4-pole motor. The rated output current of the drive output amps should be equal to or greater than the motor current. Select the appropriate capacity drive if operating the motor continuously above motor nameplate current.
- <2> Assumes operation at the rated output current. Input current rating varies depending on the power supply transformer, input reactor, wiring conditions, and power supply impedance.
- <3> DC is not available for UL/CE standards.
- <4> Rated motor capacity is calculated with a rated output voltage of 440 V.
- <5> Carrier frequency is set to 2 kHz. Current derating is required in order to raise the carrier frequency.
- <6> Carrier frequency can be increased to 8 kHz while keeping this current derating. Higher carrier frequency settings require derating.
- <7> Carrier frequency can be increased to 5 kHz while keeping this current derating. Higher carrier frequency settings require derating.

◆ Three-Phase 400 V Class Drive Models 4A0208 to 4A1200

Table A.7 Power Ratings Continued (Three-Phase 400 V Class)

Item		Specification								
Drive Models		4A0208	4A0250	4A0296	4A0362	4A0414	4A0515	4A0675	4A0930	4A1200
Maximum Applicable Motor Capacity (HP) <1>	ND Rating	150	200	250	300	350	400-450	500-550	750	1000
	HD Rating	125-150	150	200	250	300	350	400-450-500	650	900
Input Current (A) <2>	ND Rating	207	248	300	346	410	465	657	922	1158
	HD Rating	170	207	248	300	346	410	584	830	1031
Input	Rated Voltage Rated Frequency	Three-phase: 380 to 480 Vac 50/60 Hz/510 to 680 Vdc <3>								
	Allowable Voltage Fluctuation	-15 to 10%								
	Allowable Frequency Fluctuation	±5%								
	Input Power (kVA)	ND Rating	189	227	274	316	375	425	601	843
	HD Rating	155	189	227	274	316	375	534	759	943
Rated Output Capacity (kVA) <4>	ND Rating <5>	159	191	226	276	316	392	514	709	915
	HD Rating	137 <6>	165 <6>	198 <6>	232 <6>	282 <6>	343 <5>	461 <5>	617 <5>	831 <5>
Rated Output Current (A)	ND Rating <5>	208	250	296	362	414	515	675	930	1200
	HD Rating	180 <6>	216 <6>	260 <6>	304 <6>	370 <7>	450 <5>	605 <5>	810 <5>	1090 <5>
Output	Overload Tolerance	ND Rating: 120% of rated output current for 60 s HD Rating: 150% of rated output current for 60 s (Derating may be required for applications that start and stop frequently)								
	Carrier Frequency	User-adjustable between 1 and 10 kHz				User-adjustable between 1 and 5 kHz			2 kHz	
	Maximum Output Voltage (V)	Three-phase: 380 to 480 V (proportional to input voltage)							0.95 × [input voltage]	
	Maximum Output Frequency (Hz)	400 Hz (user-adjustable)							150 Hz (user-adjustable)	

- <1> The motor capacity (HP) refers to a NEC rated 4-pole motor. The rated output current of the drive output amps should be equal to or greater than the motor current. Select the appropriate capacity drive if operating the motor continuously above motor nameplate current.
- <2> Assumes operation at the rated output current. Input current rating varies depending on the power supply transformer, input reactor, wiring conditions, and power supply impedance.
- <3> DC is not available for UL/CE standards.
- <4> Rated motor capacity is calculated with a rated output voltage of 440 V.
- <5> Carrier frequency is set to 2 kHz. Current derating is required in order to raise the carrier frequency.
- <6> Carrier frequency can be increased to 5 kHz while keeping this current derating. Higher carrier frequency settings require derating.
- <7> Carrier frequency can be increased to 5 kHz while keeping this current derating. Higher carrier frequency settings require derating.

◆ Three-Phase 600 V Class Drive Models 5A0003 to 5A0032

Table A.8 Power Ratings (Three-Phase 600 V Class)

Item		Specification								
Drive Models		5A0003	5A0004	5A0006	5A0009	5A0011	5A0017	5A0022	5A0027	5A0032
Maximum Applicable Motor Capacity (HP) <1>	ND Rating	2	3	5	7.5	10	15	20	25	30
	HD Rating	1	2	3	5	7.5	10	15	20	25
Input Current (A) <2>	ND Rating	3.6	5.1	8.3	12	16	23	31	38	45
	HD Rating	1.9	3.6	5.1	8.3	12	16	23	31	38
Input	Rated Voltage Rated Frequency	Three-phase 500 to 600 Vac 50/60 Hz								
	Allowable Voltage Fluctuation	-10 (-15) to +10%								
	Allowable Frequency Fluctuation	±5%								
	Input Power (kVA)	ND Rating	4.1	5.8	9.5	14	18	26	35	43
HD Rating		2.2	4.1	5.8	9.5	14	18	26	35	43
Rated Output Capacity (kVA) <3>	ND Rating <4>	2.7	3.9	6.1	9	11	17	22	27	32
	HD Rating <4>	1.7	3.5	4.1	6.3	9.8	12	17	22	27
Rated Output Current (A)	ND Rating <4>	2.7	3.9	6.1	9	11	17	22	27	32
	HD Rating <4>	1.7	3.5	4.1	6.3	9.8	12.5	17	22	27
Output	Overload Tolerance	ND Rating: 120% of rated output current for 60 s HD Rating: 150% of rated output current for 60 s (Derating may be required for applications that start and stop frequently)								
	Carrier Frequency	User adjustable between 2 and 15 kHz					User adjustable between 2 and 10 kHz			
	Maximum Output Voltage (V)	Three-phase 500 to 600 V (proportional to input voltage)								
	Maximum Output Frequency (Hz)	400 Hz (user-set)								

- <1> The motor capacity (HP) refers to a NEC rated 4-pole motor. The rated output current of the drive output amps should be equal to or greater than the motor current. Select the appropriate capacity drive if operating the motor continuously above motor nameplate current.
- <2> Assumes operation at the rated output current. Input current rating varies depending on the power supply transformer, input reactor, wiring connections, and power supply impedance.
- <3> Rated motor capacity is calculated with a rated output voltage of 575 V.
- <4> Carrier frequency is set to 2 kHz. Current derating is required to raise the carrier frequency.
- <5> Carrier frequency can be increased to 8 kHz while keeping this current derating. Higher carrier frequency settings require derating.

◆ Three-Phase 600 V Class Drive Models 5A0041 to 5A0099

Table A.9 Power Ratings Continued (Three-Phase 600 V Class)

Item		Specification					
Drive Models		5A0041	5A0052	5A0062	5A0077	5A0099	
Maximum Applicable Motor Capacity (HP) <1>		ND Rating	40	50	60	75	100
		HD Rating	25-30	40	50-60	50-60	75
Input Current (A) <2>		ND Rating	44	54	66	80	108
		HD Rating	33	44	54	66	80
Input	Rated Voltage Rated Frequency		Three-phase 500 to 600 Vac 50/60 Hz				
	Allowable Voltage Fluctuation		-10 (-15) to +10%				
	Allowable Frequency Fluctuation		±5%				
	Input Power (kVA)	ND Rating	50	62	75	91	123
HD Rating		38	50	62	75	91	
Rated Output Capacity (kVA) <3>		ND Rating <4>	41	52	62	77	99
		HD Rating	<5>	<5>	<5>	<5>	<6>
Rated Output Current (A)		ND Rating <4>	41	52	62	77	99
		HD Rating	<5>	<5>	<5>	<5>	<6>
Output	Overload Tolerance		ND Rating: 120% of rated output current for 60 s HD Rating: 150% of rated output current for 60 s (Derating may be required for applications that start and stop frequently)				
	Carrier Frequency		User adjustable between 2 and 10 kHz				User adjustable between 2 and 8 kHz
	Maximum Output Voltage (V)		Three-phase 500 to 600 V (proportional to input voltage)				
	Maximum Output Frequency (Hz)		400 Hz (user-set)				

<1> The motor capacity (HP) refers to a NEC rated 4-pole motor. The rated output current of the drive output amps should be equal to or greater than the motor current. Select the appropriate capacity drive if operating the motor continuously above motor nameplate current.

<2> Assumes operation at the rated output current. Input current rating varies depending on the power supply transformer, input reactor, wiring connections, and power supply impedance.

<3> Rated motor capacity is calculated with a rated output voltage of 575 V.

<4> Carrier frequency can be increased to 2 kHz while keeping this current derating. Higher carrier frequency settings require derating.

<5> Carrier frequency can be increased to 8 kHz while keeping this current derating. Higher carrier frequency settings require derating.

<6> Carrier frequency can be increased to 5 kHz while keeping this current derating. Higher carrier frequency settings require derating.

◆ Three-Phase 600 V Class Drive Models 5A0125 to 5A0242

Table A.10 Power Ratings Continued (Three-Phase 600 V Class)

Item		Specification				
Drive Models		5A0125	5A0145	5A0192	5A0242	
Maximum Applicable Motor Capacity (HP) <1>	ND Rating	125	150	200	250	
	HD Rating	100	125	150	200	
Input	Input Current (A) <2>	ND Rating	129	158	228	263
		HD Rating	108	129	158	228
	Rated Voltage Rated Frequency		Three-phase 500 to 600 Vac 50/60 Hz			
	Allowable Voltage Fluctuation		-10 (-15) to +10%			
	Allowable Frequency Fluctuation		±5%			
	Input Power (kVA)	ND Rating	147	181	261	301
HD Rating		123	147	181	261	
Output	Rated Output Capacity (kVA) <3>	ND Rating <4>	124	144	191	241
		HD Rating <4>	99	129	171	199
	Rated Output Current (A)	ND Rating <4>	125	145	192	242
		HD Rating <4>	99	130	172	200
	Overload Tolerance		ND Rating: 120% of rated output current for 60 s HD Rating: 150% of rated output current for 60 s (Derating may be required for applications that start and stop frequently)			
	Carrier Frequency		User adjustable between 2 and 3kHz			
	Maximum Output Voltage (V)		Three-phase 500 to 600 V (proportional to input voltage)			
	Maximum Output Frequency (Hz)		400 Hz (user-set)			

<1> The motor capacity (HP) refers to a NEC rated 4-pole motor. The rated output current of the drive output amps should be equal to or greater than the motor current. Select the appropriate capacity drive if operating the motor continuously above motor nameplate current.

<2> Assumes operation at the rated output current. Input current rating varies depending on the power supply transformer, input reactor, wiring connections, and power supply impedance.

<3> Rated motor capacity is calculated with a rated output voltage of 575 V.

<4> Carrier frequency can be increased to 2 kHz while keeping this current derating. Higher carrier frequency settings require derating.

<5> Carrier frequency can be increased to 8 kHz while keeping this current derating. Higher carrier frequency settings require derating.

<6> Carrier frequency can be increased to 5 kHz while keeping this current derating. Higher carrier frequency settings require derating.

A.3 Drive Specifications

- Note:**
1. Perform rotational Auto-Tuning to obtain the performance specifications given below.
 2. For optimum performance life of the drive, install the drive in an environment that meets the required specifications.

Item	Specification
Control Method	The following control methods can be set using drive parameters: <ul style="list-style-type: none"> • V/f Control (V/f) • V/f Control with PG (V/f w/PG) • Open Loop Vector Control (OLV) • Closed Loop Vector Control (CLV) • Open Loop Vector Control for PM (OLV/PM) • Advanced Open Loop Vector Control for PM (AOLV/PM) • Closed Loop Vector Control for PM (CLV/PM) Note: PM motor control modes are not available on 600 V class drives, models 5A□□□□.
Frequency Control Range	0.01 to 400 Hz
Frequency Accuracy (Temperature Fluctuation)	Digital input: within ±0.01% of the max output frequency (-10 to +40 °C) Analog input: within ±0.1% of the max output frequency (25 °C ±10 °C)
Frequency Setting Resolution	Digital inputs: 0.01 Hz Analog inputs: 1/2048 of the maximum output frequency setting (11 bit plus sign)
Output Frequency Resolution	0.001 Hz
Frequency Setting Signal	Main speed frequency reference: DC -10 to +10 V (20 kΩ), DC 0 to +10 V (20 kΩ), 4 to 20 mA (250 Ω), 0 to 20 mA (250 Ω) Main speed reference: Pulse train input (max. 32 kHz)
Starting Torque <2>	V/f, V/f w/PG: 150% at 3 Hz OLV: 200% at 0.3 Hz <2> CLV, AOLV/PM, CLV/PM: 200% at 0.0 r/min <2> OLV/PM: 100% at 3 Hz
Speed Control Range <2>	V/f, V/f w/PG: 1:40 OLV: 1:200 CLV, CLV/PM: 1:1500 OLV/PM: 1:20 AOLV/PM: 1:100
Speed Control Accuracy <2>	OLV: ±0.2% (25 °C ±10 °C) CLV: ±0.02% (25 °C ±10 °C)
Speed Response <2>	OLV, OLV/PM, AOLV/PM: 10 Hz CLV, CLV/PM: 50 Hz
Torque Limit	Parameters setting allow separate limits in four quadrants (available in OLV, CLV, AOLV/PM, CLV/PM)
Accel/Decel Time	0.0 to 6000.0 s (4 selectable combinations of independent acceleration and deceleration settings)
Braking Torque	Approx. 20% (approx. 125% when using braking resistor) <3> <ul style="list-style-type: none"> • Short-time decel torque <4> : over 100% for 0.4/ 0.75 kW motors, over 50% for 1.5 kW motors, and over 20% for 2.2 kW and above motors <5> (overexcitation braking/High Slip Braking: approx. 40%) • Continuous regenerative torque: approx. 20% <5> (approx. 125% with dynamic braking resistor option <3> : 10% ED, 10s)
Braking Transistor	Models 2A0004 to 2A0138, 4A0002 to 4A0072, and 5A0003 to 5A0052 have a built-in braking transistor.
V/f Characteristics	User-selected programs and V/f preset patterns possible
Main Control Functions	Torque Control, Droop Control, Speed/torque Control Switching, Feed Forward Control, Zero Servo Function, Momentary Power Loss Ride-Thru, Speed Search, Overtorque/Undertorque Detection, Torque Limit, 17 Step Speed (max), Accel/decel Switch, S-curve Accel/decel, 3-wire Sequence, Auto-tuning (rotational, stationary tuning), Dwell, Cooling Fan on/off Switch, Slip Compensation, Torque Compensation, Frequency Jump, Upper/lower Limits for Frequency Reference, DC Injection Braking at Start and Stop, Overexcitation Braking, High Slip Braking, PID Control (with sleep function), Energy Saving Control, MEMOBUS/Modbus Comm. (RS-422/RS-485 max, 115.2 kbps), Fault Restart, Application Presets, DriveWorksEZ (customized function), Removable Terminal Block with Parameter Backup Function, Online Tuning, KEB, Overexcitation Deceleration, Inertia (ASR) Tuning, Overvoltage Suppression, High Frequency Injection.

Item		Specification
Protection Functions	Motor Protection	Electronic thermal overload relay
	Momentary Overcurrent Protection	Drive stops when output current exceeds 200% of Heavy Duty Rating
	Overload Protection	Drive stops after 60 s at 150% of rated Heavy Duty output current <6>
	Overvoltage Protection	200 V class: Stops when DC bus voltage exceeds approx. 410 V 400 V class: Stops when DC bus voltage exceeds approx. 820 V 600 V class: Stops when DC bus voltage exceeds approx. 1040 V
	Undervoltage Protection	200 V class: Stops when DC bus voltage falls below approx. 190 V 400 V class: Stops when DC bus voltage falls below approx. 380 V 600 V class: Stops when DC bus voltage falls below approx. 475 V
	Momentary Power Loss Ride-Thru	Immediately stop after 15 ms or longer power loss <7> . Continuous operation during power loss than 2 s (standard) <8>
	Heatsink Overheat Protection	Thermistor
	Braking Resistor Overheat Protection	Overheat input signal for braking resistor (Optional ERF-type, 3% ED)
	Stall Prevention	Stall Prevention is available during acceleration, deceleration, and during run.
	Ground Protection	Electronic circuit protection <9>
	DC Bus Charge LED	Remains lit until DC bus voltage falls below 50 V
Environment	Area of Use	Indoors
	Ambient Temperature	-10 to +40 °C (IP20/NEMA Type 1 enclosure), -10 to +50 °C (IP00/Open Type enclosure)
	Humidity	95 RH% or less (no condensation)
	Storage Temperature	-20 to +60 °C (short-term temperature during transportation)
	Altitude	Up to 1000 meters without derating, up to 3000 m with output current and voltage derating. <i>Refer to Altitude Derating on page 487</i> for details.
	Vibration/Shock	10 to 20 Hz: 9.8 m/s ² <10> 20 to 55 Hz: 5.9 m/s ² (2A0004 to 2A0211, 4A0002 to 4A0165, and 5A0003 to 5A0099) 2.0 m/s ² (2A0250 to 2A0415, 4A0208 to 4A1200, and 5A0125 to 5A0242)
Safety Standard		UL 508C, EN61800-5-1, ISO13849 Cat. 3, IEC/EN61508 SIL2, CSA <11>
Protection Design		IP00/Open Type enclosure, IP20/NEMA Type 1 enclosure <12>

- <1> Select control modes in accordance with drive capacity.
- <2> The accuracy of these values depends on motor characteristics, ambient conditions, and drive settings. Specifications may vary with different motors and with changing motor temperature. Contact Yaskawa for consultation.
- <3> Disable Stall Prevention during deceleration (L3-04 = 0) when using a regenerative converter, a regenerative unit, a braking resistor or the Braking Resistor Unit. The default setting for the Stall Prevention function will interfere with the braking resistor.
- <4> Instantaneous average deceleration torque refers to the torque required to decelerate the motor (uncoupled from the load) from the rated motor speed down to zero in the shortest time.
- <5> Actual specifications may vary depending on motor characteristics.
- <6> Overload protection may be triggered when operating with 150% of the rated output current if the output frequency is less than 6 Hz.
- <7> May be shorter due to load conditions and motor speed.
- <8> A separate Momentary Power Loss Ride-Thru Unit is required for models 2A0004 to 2A0056 and 4A0002 to 4A0031 if the application needs to continue running for up to 2 seconds during a momentary power loss.
- <9> Ground protection cannot be provided when the impedance of the ground fault path is too low, or when the drive is powered up while a ground fault is present at the output.
- <10> Models 4A0930 and 4A1200 are rated at 5.9 m/s².
- <11> Terminals H1, H2, DM+, and DM- on 600 V class models are designed to the functionality, but are not certified to Insulation coordination: class 1.
- <12> Removing the top protective cover or bottom conduit bracket from an IP20/NEMA Type 1 enclosure drive voids NEMA Type 1 protection while maintaining IP20 conformity. This is applicable to models 2A0004 to 2A0211, 4A0002 to 4A0165, and 5A0003 to 5A0242.

A.4 Drive Watt Loss Data

Table A.11 Watt Loss 200 V Class Three-Phase Models

Drive Model	Normal Duty				Heavy Duty			
	Rated Amps (A) <3>	Heatsink Loss (W)	Interior Unit Loss (W)	Total Loss (W)	Rated Amps (A)	Heatsink Loss (W)	Interior Unit Loss (W)	Total Loss (W)
2A0004	3.5	18.4	47	66	3.2 <1>	14.8	44	59
2A0006	6.0	31	51	82	5.0 <1>	24	48	72
2A0008	8.0	43	52	95	6.9 <1>	35	49	84
2A0010	9.6	57	58	115	8.0 <1>	43	52	95
2A0012	12.0	77	64	141	11.0 <1>	64	58	122
2A0018	17.5	101	67	168	14.0 <1>	77	60	137
2A0021	21	138	83	222	17.5 <1>	101	67	168
2A0030	30	262	117	379	25 <1>	194	92	287
2A0040	40	293	145	437	33 <1>	214	105	319
2A0056	56	371	175	546	47 <1>	280	130	410
2A0069	69	491	205	696	60 <1>	395	163	558
2A0081	81	527	257	785	75 <1>	460	221	681
2A0110	110	719	286	1005	85 <1>	510	211	721
2A0138	138	842	312	1154	115 <1>	662	250	912
2A0169	169	1014	380	1394	145 <1>	816	306	1122
2A0211	211	1218	473	1691	180 <2>	976	378	1354
2A0250	250	1764	594	2358	215 <2>	1514	466	1980
2A0312	312	2020	665	2686	283 <2>	1936	588	2524
2A0360	360	2698	894	3591	346 <2>	2564	783	3347
2A0415	415	2672	954	3626	415 <3>	2672	954	3626

<1> Value assumes the carrier frequency is set to 8 kHz or less.

<2> Value assumes the carrier frequency is set to 5 kHz or less.

<3> Value assumes the carrier frequency is set to 2 kHz.

Table A.12 Watt Loss 400 V Class Three-Phase Models

Drive Model	Normal Duty				Heavy Duty			
	Rated Amps (A) <3>	Heatsink Loss (W)	Interior Unit Loss (W)	Total Loss (W)	Rated Amps (A)	Heatsink Loss (W)	Interior Unit Loss (W)	Total Loss (W)
4A0002	2.1	20	48	68	1.8 <1>	15.9	45	61
4A0004	4.1	32	49	81	3.4 <1>	25	46	70
4A0005	5.4	45	53	97	4.8 <1>	37	49	87
4A0007	6.9	62	59	121	5.5 <1>	48	53	101
4A0009	8.8	66	60	126	7.2 <1>	53	55	108
4A0011	11.1	89	73	162	9.2 <1>	69	61	130
4A0018	17.5	177	108	285	14.8 <1>	135	86	221
4A0023	23	216	138	354	18.0 <1>	150	97	247
4A0031	31	295	161	455	24 <1>	208	115	323
4A0038	38	340	182	521	31 <1>	263	141	403
4A0044	44	390	209	599	39 <1>	330	179	509
4A0058	58	471	215	686	45 <1>	349	170	518
4A0072	72	605	265	870	60 <1>	484	217	701

Drive Model	Normal Duty				Heavy Duty			
	Rated Amps (A) <3>	Heatsink Loss (W)	Interior Unit Loss (W)	Total Loss (W)	Rated Amps (A)	Heatsink Loss (W)	Interior Unit Loss (W)	Total Loss (W)
4A0088	88	684	308	993	75 <1>	563	254	817
4A0103	103	848	357	1205	91 <1>	723	299	1022
4A0139	139	1215	534	1749	112 <2>	908	416	1325
4A0165	165	1557	668	2224	150 <2>	1340	580	1920
4A0208	208	1800	607	2408	180 <2>	1771	541	2313
4A0250	250	2379	803	3182	216 <2>	2360	715	3075
4A0296	296	2448	905	3353	260 <2>	2391	787	3178
4A0362	362	3168	1130	4298	304 <2>	3075	985	4060
4A0414	414	3443	1295	4738	370 <2>	3578	1164	4742
4A0515	515	4850	1668	6518	450 <2>	3972	1386	5358
4A0675	675	4861	2037	6898	605 <2>	4191	1685	5875
4A0930	930	8476	2952	11428	810 <2>	6912	2455	9367
4A1200	1200	8572	3612	12184	1090 <3>	7626	3155	10781

<1> Value assumes the carrier frequency is set to 8 kHz or less.

<2> Value assumes the carrier frequency is set to 5 kHz or less.

<3> Value assumes the carrier frequency is set to 2 kHz.

Table A.13 Watt Loss Three-Phase 600 V Class Three-Phase Models

Drive Model	Normal Duty				Heavy Duty			
	Rated Amps (A) <3>	Heatsink Loss (W)	Interior Unit Loss (W)	Total Loss (W)	Rated Amps (A)	Heatsink Loss (W)	Interior Unit Loss (W)	Total Loss (W)
5A0003	2.7	21.5	23.3	44.8	1.7 <2>	28.9	19.8	48.7
5A0004	3.9	27.5	33.6	61.1	3.5 <2>	54.3	27.6	81.9
5A0006	6.1	28.1	43.7	71.8	4.1 <2>	53.0	27.0	80.0
5A0009	9.0	43.4	68.9	112.3	6.3 <2>	78.7	36.4	115.1
5A0011	11	56.1	88.0	144.0	9.8 <2>	110.9	49.5	160.3
5A0017	17	96.6	146.7	243.2	12.5 <2>	144.7	67.5	212.2
5A0022	22	99.4	178.3	277.7	17 <2>	203.8	81.1	284.8
5A0027	27	132.1	227.2	359.3	22 <1>	267.2	113.8	381.1
5A0032	32	141.6	279.9	421.5	27 <1>	332.9	132.2	465.1
5A0041	41	330.8	136.2	467.0	32 <1>	405.9	127.6	533.5
5A0052	52	427.8	166.2	594.0	41 <1>	527.2	161.4	688.5
5A0062	62	791.2	279.0	1070.2	52 <1>	1271.5	335.0	1606.5
5A0077	77	959.1	329.4	1288.6	62 <1>	1457.0	379.5	1836.5
5A0099	99	1253.2	411.7	1664.9	77 <2>	1267.0	352.0	1619.0
5A0125	125	1641	537	2178	99 <3>	1328	422	1750
5A0145	145	1860	603	2463	130 <3>	1638	508	2146
5A0192	192	2420	769	3189	172 <3>	2114	648	2762
5A0242	242	3100	1131	4231	200 <3>	2526	896	3422

<1> Value assumes the carrier frequency is set to 8 kHz or less.

<2> Value assumes the carrier frequency is set to 5 kHz or less.

<3> Value assumes the carrier frequency is set to 2 kHz.

A.5 Drive Derating Data

The drive can be operated at above the rated temperature, altitude, and default carrier frequency by derating the drive capacity.

◆ Single-Phase Derating

A1000 drives are optimized and compatible for use with both three-phase and single-phase input power supplies. The A1000 output to the motor is fixed at three-phase.

A1000 output capacity to the motor is reduced or derated when single-phase input power is used.

Selection of larger A1000 models always results in greater output capacity to the motor when the A1000 is supplied with three-phase input power. Conversely, selection of larger A1000 models does not always yield greater output capacity when the A1000 is used with single-phase input power. Several factors affect the amount of derated drive output capacity when single-phase input power is supplied to the A1000, such as:

- single-phase input voltage level
- motor voltage rating
- amount of input impedance.

The tables in this section assist in A1000 model selection by considering factors that affect the amount of A1000 derating in single-phase input power applications.

The continuous output current listed in the tables allows for a 120% overload for 60 seconds.

Contact Yaskawa if assistance is needed in selecting A1000 drive models for heavy duty/single-phase applications with higher overload requirements.

Table A.14 240 V Single-Phase Input (-5% to +10%), 230 V Three-Phase Motor

Drive Model	Without Additional Impedance				With Additional Impedance (use either DC type or AC type)					
	Output Capacity		Single Phase Input Load		Yaskawa Reactor Part Number		Output Capacity		Single Phase Input Load	
	Motor Power (HP)	Motor FLA	Power (kVA)	Continuous Output Current (A)	DC Type	AC Type	Motor Power (HP)	Motor FLA	Power (kVA)	Continuous Output Current (A)
2A0004	0.33	1.52	0.99	4.3	URX000043	URX000303	0.5	2.2	0.94	4.1
2A0006	0.5	2.2	1.3	5.7	URX000043	URX000303	0.75	3.2	1.3	5.7
2A0008	0.75	3.2	1.7	7.7	05P00620-0113	URX000307	1	4.2	1.6	7.2
2A0010	0.75	3.2	1.8	7.7	05P00620-0113	URX000311	1	4.2	1.8	7.8
2A0012	1	4.2	2.3	10	URX000048	URX000316	2	7.5	2.9	13
2A0018	2	6.8	4.3	19	05P00620-0120	URX000319	3	9.6	4.3	19
2A0021	2	6.8	4.3	19	05P00620-0120	URX000323	3	9.6	4.4	19
2A0030	2	6.8	4.5	20	05P00620-0120	URX000323	3	9.6	4.4	19
2A0040	3	9.6	6.2	27	05P00620-0124	URX000323	5	15.2	6.7	30
2A0056	5	15.2	9.9	43	URX000059	URX000326	7.5	22	9.6	42
2A0069	5	15.2	10	45	URX000063	URX000332	10	28	13	56
2A0081	10	28	18	79	URX000072	URX000338	15	42	19	84
2A0110	10	28	14	60	DC Link Choke Built-in	Do Not Use AC Reactor	10	28	14	60
2A0138	15	42	20	87			15	42	20	87
2A0169	20	54	26	114			20	54	26	114
2A0211	20	54	26	116			20	54	26	116
2A0250	25	68	32	143			25	68	32	143
2A0312	30	80	39	170			30	80	39	170
2A0360	40	104	51	224			40	104	51	224
2A0415	50	130	63	275			50	130	63	275

Table A.15 240 V Single-Phase Input (-5% to +10%), 208 V Three-Phase Motor

Drive Model	Without Additional Impedance				With Additional Impedance (use either DC type or AC type)					
	Output Capacity		Single Phase Input Load		Yaskawa Reactor Part Number		Output Capacity		Single Phase Input Load	
	Motor Power (HP)	Motor FLA	Power (kVA)	Continuous Output Current (A)	DC Type	AC Type	Motor Power (HP)	Motor FLA	Power (kVA)	Continuous Output Current (A)
2A0004	0.33	1.7	0.99	4.3	URX000043	URX000303	0.5	2.4	0.94	4.1
2A0006	0.5	2.4	1.3	5.7	URX000043	URX000303	0.75	3.5	1.3	5.7
2A0008	0.75	3.5	1.7	7.7	05P00620-0113	URX000307	1	4.6	1.6	7.2
2A0010	0.75	3.5	1.8	7.7	05P00620-0113	URX000311	1	4.6	1.8	7.8
2A0012	1	4.6	2.3	10	05P00620-0115	URX000315	2	7.5	2.9	13
2A0018	2	7.5	4.3	19	05P00620-0120	URX000319	3	10.6	4.3	19
2A0021	2	7.5	4.3	19	05P00620-0120	URX000323	3	10.6	4.4	19
2A0030	2	7.5	4.5	20	05P00620-0120	URX000323	3	10.6	4.4	19
2A0040	3	10.6	6.2	27	05P00620-0124	URX000323	5	17	6.7	30
2A0056	5	17	9.9	43	URX000059	URX000326	7.5	24	9.6	42
2A0069	5	17	10	45	URX000063	URX000332	10	31	13	56
2A0081	10	31	18	79	URX000072	URX000339	15	46	19	84
2A0110	10	31	14	60	DC Link Choke Built-in	URX000340	15	46	17	76
2A0138	15	46	20	87		URX000343	15	46	18	77
2A0169	20	59	26	114		URX000342	20	59	23	102
2A0211	20	59	26	116		URX000344	25	75	29	129
2A0250	25	75	32	143		URX000347	30	88	35	156
2A0312	30	88	39	170		URX000350	40	114	47	204
2A0360	40	114	51	224		URX000353	50	143	57	252
2A0415	50	143	63	275		URX000356	60	169	69	301

Table A.16 480 V Single-Phase Input (-5% to +10%), 460 V Three-Phase Motor

Drive Model	Without Additional Impedance				With Additional Impedance (use either DC type or AC type)					
	Output Capacity		Single Phase Input Load		Yaskawa Reactor Part Number		Output Capacity		Single Phase Input Load	
	Motor Power (HP)	Motor FLA	Power (kVA)	Continuous Output Current (A)	DC Type	AC Type	Motor Power (HP)	Motor FLA	Power (kVA)	Continuous Output Current (A)
4A0002	0.33	0.76	1.1	2.4	URX000041	URX000295	0.5	1.1	0.98	2.1
4A0004	0.75	1.6	1.9	4.2	URX000041	URX000299	1	2.1	1.7	3.8
4A0005	1	2.1	2.3	5.1	05P00620-0110	URX000303	1.5	3	2.5	5.5
4A0007	1	2.1	2.5	5.6	05P00652-0213	URX000308	2	3.4	3	6.7
4A0009	2	3.4	4.6	10	URX000048	URX000312	3	4.8	4.3	9.5
4A0011	2	3.4	4.6	10	URX000053	URX000316	3	4.8	4.7	10
4A0018	2	3.4	4.4	9.7	URX000052	URX000316	3	4.8	4.6	10
4A0023	3	4.8	6.3	14	URX000052	URX000316	5	7.6	7	15
4A0031	5	7.6	10	22	URX000055	URX000324	7.5	11	9.9	22
4A0038	7.5	11	14	31	05P00620-0123	URX000327	10	14	14	31
4A0044	7.5	11	14	31	URX000061	URX000327	10	14	13	28

A.5 Drive Derating Data

Drive Model	Without Additional Impedance				With Additional Impedance (use either DC type or AC type)					
	Output Capacity		Single Phase Input Load		Yaskawa Reactor Part Number		Output Capacity		Single Phase Input Load	
	Motor Power (HP)	Motor FLA	Power (kVA)	Continuous Output Current (A)	DC Type	AC Type	Motor Power (HP)	Motor FLA	Power (kVA)	Continuous Output Current (A)
4A0058	10	14	14	30	DC Link Choke Built-in	URX000332	15	21	19	41
4A0072	15	21	20	43		Do Not Use AC Reactor	15	21	20	43
4A0088	15	21	20	44			15	21	20	44
4A0103	15	21	20	45		URX000335	20	27	25	54
4A0139	30	40	38	84		URX000341	30	40	36	80
4A0165	30	40	39	85		URX000341	30	40	37	81
4A0208	50	65	62	136		URX000347	50	65	59	130
4A0250	60	77	74	162		URX000347	60	77	70	154
4A0296	60	77	75	165		URX000350	75	96	87	192
4A0362	75	96	93	205		URX000353	100	124	115	251
4A0414	100	124	122	267		URX000356	125	156	143	314
4A0515	100	124	125	275		URX000353	100	124	116	255
4A0675	125	156	157	345		Do Not Use	125	156	157	345

Table A.17 480 V Single-Phase Input (-5% to +10%), 400 V Three-Phase Motor

Drive Model	Without Additional Impedance				With Additional Impedance (use either DC type or AC type)					
	Output Capacity		Single Phase Input Load		Yaskawa Reactor Part Number		Output Capacity		Single Phase Input Load	
	Motor Power (HP)	Motor FLA	Power (kVA)	Continuous Output Current (A)	DC Type	AC Type	Motor Power (HP)	Motor FLA	Power (kVA)	Continuous Output Current (A)
4A0002	0.33	0.88	1.1	2.4	URX000041	URX000295	0.5	1.26	0.98	2.1
4A0004	0.75	1.8	1.9	4.2	URX000041	URX000299	1	2.4	1.7	3.8
4A0005	1	2.4	2.3	5.1	05P00620-0110	URX000303	1.5	3.4	2.5	5.5
4A0007	1	2.4	2.5	5.6	05P00652-0213	URX000308	2	3.9	3	6.7
4A0009	2	3.9	4.6	10	URX000048	URX000312	3	5.5	4.3	9.5
4A0011	2	3.9	4.6	10	URX000053	URX000316	3	5.5	4.7	10
4A0018	2	3.9	4.4	9.7	URX000052	URX000316	3	5.5	4.6	10
4A0023	3	5.5	6.3	14	URX000052	URX000316	5	8.7	7	15
4A0031	5	8.7	10	22	URX000055	URX000324	7.5	12.7	9.9	22
4A0038	7.5	12.7	14	31	05P00620-0123	URX000327	10	16	14	31
4A0044	7.5	12.7	14	31	URX000061	URX000327	10	16	13	28
4A0058	10	16	14	30	DC Link Choke Built-in	URX000332	15	24	19	41
4A0072	15	24	20	43		URX000336	20	31	24	52
4A0088	15	24	20	44		URX000336	20	31	24	52
4A0103	15	24	20	45		URX000335	20	31	25	54
4A0139	30	46	38	84		URX000341	30	46	36	80
4A0165	30	46	39	85		URX000341	30	46	37	81
4A0208	50	75	62	136		URX000347	50	75	59	130
4A0250	60	89	74	162		URX000347	60	89	70	154
4A0296	60	89	75	165		URX000350	75	110	87	192
4A0362	75	110	93	205		URX000353	100	143	115	251
4A0414	100	143	122	267		URX000356	125	179	143	314
4A0515	100	143	125	275		URX000353	100	143	116	255
4A0675	125	179	157	345		URX000360	150	207	169	371

Table A.18 600 V Single-Phase Input (-5% to +10%), 575 V Three-Phase Motor

Drive Model	Without Additional Impedance				With Additional Impedance (use either DC type or AC type)					
	Output Capacity		Single Phase Input Load		Yaskawa Reactor Part Number		Output Capacity		Single Phase Input Load	
	Motor Power (HP)	Motor FLA	Power (kVA)	Continuous Output Current (A)	DC Type	AC Type	Motor Power (HP)	Motor FLA	Power (kVA)	Continuous Output Current (A)
5A0003	1	1.7	2	3.5	05P00620-0110	URX000303	1.5	2.4	2.6	4.6
5A0004	1.5	2.4	2.7	4.8	URX000044	URX000306	2	2.7	2.9	5
5A0006	2	2.7	4	7	05P00652-0213	URX000308	3	3.9	4.3	7.6
5A0009	3	3.9	5.4	9.5	URX000049	URX000313	5	6.1	6.5	11
5A0011	2	2.7	4.1	7.1	05P00652-0213	URX000308	3	3.9	4.4	7.7
5A0017	5	6.1	9.1	16	URX000048	URX000316	5	6.1	7.1	12
5A0022	5	6.1	9.2	16	URX000053	URX000320	7.5	9	10	18
5A0027	7.5	9	14	24	URX000055	URX000324	10	11	13	23
5A0032	7.5	9	14	24	URX000055	URX000324	10	11	13	23
5A0041	10	11	14	24	DC Link Choke Built-in	URX000326	15	17	18	32
5A0052	15	17	19	34		URX000326	15	17	19	32
5A0062	20	22	27	47		URX000335	25	27	31	54
5A0077	25	27	32	57		URX000338	30	32	36	64
5A0099	30	32	38	66		URX000338	30	32	37	64
5A0125	40	41	49	86		URX000344	50	52	58	102
5A0145	40	41	49	86		URX000344	50	52	58	102
5A0192	60	62	74	130		URX000347	75	77	87	152
5A0242	75	77	91	159		URX000347	75	77	87	152

■ Rated Current Depending on Carrier Frequency

The table below shows the drive output current depending on the carrier frequency settings.

Normal Duty Rating (ND)

The 2 kHz values shown for ND in [Table A.21](#) are equal to the drive rated current shown on the drive nameplate. Increasing the carrier frequency above 2 kHz will reduce the ND rated output current of the drive as shown in [Table A.21](#).

Heavy Duty Rating (HD)

A carrier frequency setting of 8 kHz or lower is equal to the drive rated current shown on the drive nameplate. The factory default setting for carrier frequency in HD mode is 2 kHz. Increasing the carrier frequency above 8 kHz will reduce the HD rated output current of the drive as shown in the following tables.

Use the data in the following tables to linearly calculate output current values for carrier frequencies not listed.

Table A.19 Three-Phase 200 V Class Carrier Frequency and Current Derating

Three-Phase 200 V Class						
Drive Model	Rated Current [A]					
	Normal Duty Rating (ND)			Heavy Duty Rating (HD)		
	2 kHz	8 kHz	15 kHz	2 kHz	8 kHz	15 kHz
2A0004	3.5	3.2	2.56	3.2	3.2	2.56
2A0006	6	5	4	5	5	4
2A0008	8	6.9	5.5	6.9	6.9	5.5
2A0010	9.6	8	6.4	8	8	6.4
2A0012	12	11	8.8	11	11	8.8
2A0018	17.5	14	11.2	14	14	11.2
2A0021	21	17.5	14	17.5	17.5	14
2A0030	30	25	20	25	25	20
2A0040	40	33	26.4	33	33	26.4

A.5 Drive Derating Data

Three-Phase 200 V Class						
Drive Model	Rated Current [A]					
	Normal Duty Rating (ND)			Heavy Duty Rating (HD)		
	2 kHz	8 kHz	15 kHz	2 kHz	8 kHz	15 kHz
2A0056	56	47	37.6	47	47	37.6
2A0069	69	60	48	60	60	48
2A0081	81	75	53	75	75	53
2A0110	110	85	60	85	85	60
2A0138	138	115	81	115	115	81

Three-Phase 200 V Class						
Drive Model	Rated Current [A]					
	Normal Duty Rating (ND)			Heavy Duty Rating (HD)		
	2 kHz	5 kHz	10 kHz	2 kHz	5 kHz	10 kHz
2A0169	169	145	116	145	145	116
2A0211	211	180	144	180	180	144
2A0250	250	215	172	215	215	172
2A0312	312	283	226	283	283	226
2A0360	360	346	277	346	346	277
2A0415	415	415	332	415	415	332

Table A.20 Three-Phase 400 V Class Carrier Frequency and Current Derating

Three-Phase 400 V Class						
Drive Model	Rated Current [A]					
	Normal Duty Rating (ND)			Heavy Duty Rating (HD)		
	2 kHz	8 kHz	15 kHz	2 kHz	8 kHz	15 kHz
4A0002	2.1	1.8	1.1	1.8	1.8	1.1
4A0004	4.1	3.4	2	3.4	3.4	2
4A0005	5.4	4.8	2.9	4.8	4.8	2.9
4A0007	6.9	5.5	3.3	5.5	5.5	3.3
4A0009	8.8	7.2	4.3	7.2	7.2	4.3
4A0011	11.1	9.2	5.5	9.2	9.2	5.5
4A0018	17.5	14.8	8.9	14.8	14.8	8.9
4A0023	23	18	10.8	18	18	10.8
4A0031	31	24	14.4	24	24	14.4
4A0038	38	31	18.6	31	31	18.6
4A0044	44	39	23.4	39	39	23.4
4A0058	58	45	27	45	45	27
4A0072	72	60	36	60	60	36
4A0088	88	75	45	75	75	45
4A0103	103	91	55	91	91	55

Three-Phase 400 V Class						
Drive Model	Rated Current [A]					
	Normal Duty Rating (ND)			Heavy Duty Rating (HD)		
	2 kHz	5 kHz	10 kHz	2 kHz	5 kHz	10 kHz
4A0139	139	112	78	112	112	78
4A0165	165	150	105	150	150	105
4A0208	208	180	126	180	180	126
4A0250	250	216	151	216	216	151
4A0296	296	260	182	260	260	182
4A0362	362	304	213	304	304	213

Three-Phase 400 V Class						
Drive Model	Rated Current [A]					
	Normal Duty Rating (ND)			Heavy Duty Rating (HD)		
	2 kHz	5 kHz	10 kHz	2 kHz	5 kHz	10 kHz
4A0414	414	370	–	370	370	–
4A0515	515	397	–	450	375	–
4A0675	675	528	–	605	504	–
4A0930	930	716	–	810	675	–
4A1200	1200	938	–	1090	908	–

Table A.21 Carrier Frequency and Current Derating

Three-Phase 600 V Class								
Drive Model	Rated Current [A]							
	Normal Duty Rating (ND)				Heavy Duty Rating (HD)			
	2 kHz	8 kHz	10 kHz	15 kHz	2 kHz	8 kHz	10 kHz	15 kHz
5A0003	2.7	2.2	2.0	1.3	1.7	1.7	1.5	1.0
5A0004	3.9	3.4	3.1	2.1	3.5	3.5	3.1	2.1
5A0006	6.1	4.9	4.3	2.9	4.1	4.1	3.6	2.5
5A0009	9	7.5	6.6	4.5	6.3	6.3	5.6	3.8
5A0011	11	9.3	8.2	5.6	9.8	9.8	8.7	5.9
5A0017	17	13.3	11.8	–	12.5	12.5	11.1	–
5A0022	22	17.0	15.1	–	17	17	15.1	–
5A0027	27	22.0	19.5	–	22	22	19.5	–
5A0032	32	27.3	24.4	–	27	27	23.9	–

Three-Phase 600 V Class								
Drive Model	Rated Current [A]							
	Normal Duty Rating (ND)				Heavy Duty Rating (HD)			
	2 kHz	5 kHz	8 kHz	10 kHz	2 kHz	5 kHz	8 kHz	10 kHz
5A0041	41.0	39.7	33.5	29.4	32.0	32.0	32.0	28.3
5A0052	52.0	50.3	42.5	37.3	41.0	41.0	41.0	36.2
5A0062	62.0	61.3	49.7	41.9	52.0	52.0	52.0	43.8
5A0077	77.0	76.2	61.7	52.0	62.0	62.0	62.0	52.2
5A0099	99.0	80.0	55.1	–	77.0	77.0	53.9	–

Three-Phase 600 V Class				
Drive Model	Rated Current [A]			
	Normal Duty Rating (ND)		Heavy Duty Rating (HD)	
	2 kHz	3 kHz	2 kHz	3 kHz
5A0125	125.0	93.0	99.0	82.0
5A0145	145.0	108.0	130.0	108.0
5A0192	192.0	148.0	172.0	161.0
5A0242	242.0	187.0	200.0	187.0

◆ Carrier Frequency Derating

Derate the drive according to *Figure A.1* to *Figure A.11* as the carrier frequency increases above the factory default setting.

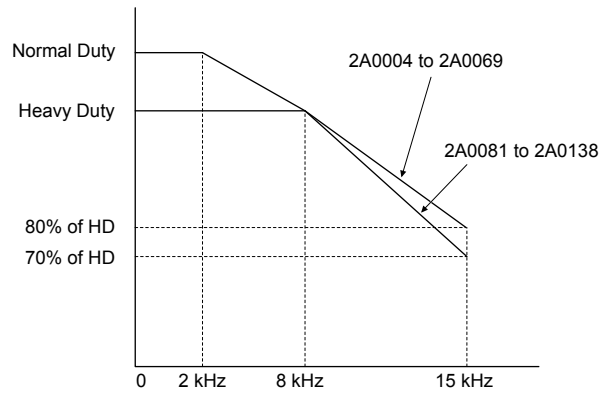

Figure A.1 Carrier Frequency Derating (Models 2A0004 to 2A0138)

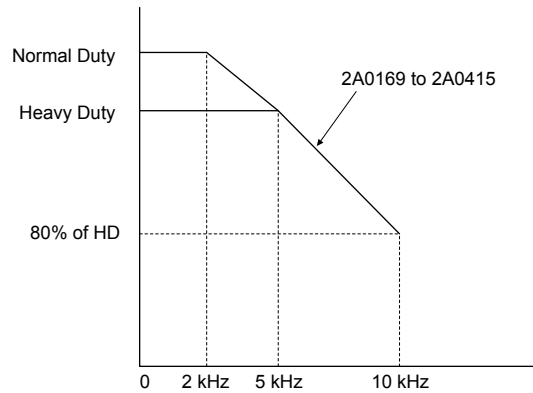

Figure A.2 Carrier Frequency Derating (Models 2A0169 to 2A0415)

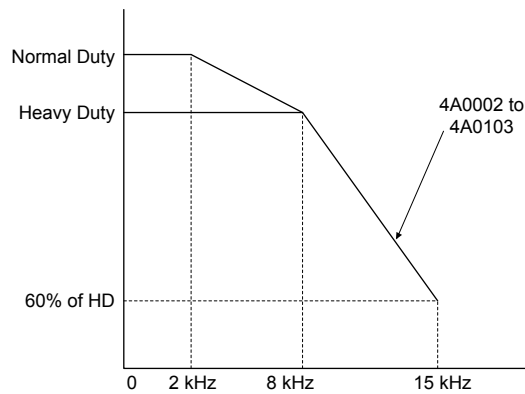

Figure A.3 Carrier Frequency Derating (Models 4A0002 to 4A0103)

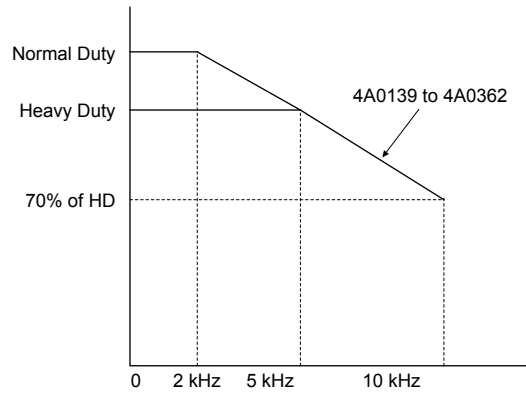

Figure A.4 Carrier Frequency Derating (Models 4A0139 to 4A0362)

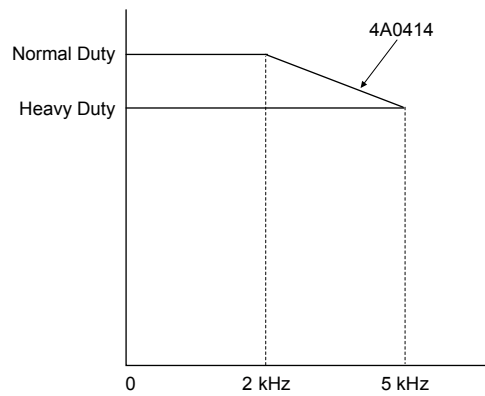

Figure A.5 Carrier Frequency Derating (Model 4A0414)

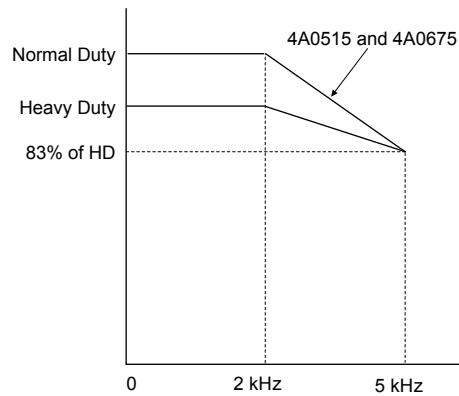

Figure A.6 Carrier Frequency Derating (Models 4A0515 and 4A0675)

A.5 Drive Derating Data

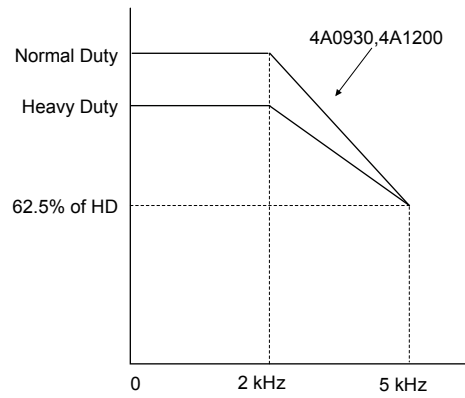

Figure A.7 Carrier Frequency Derating (Models 4A0930 and 4A1200)

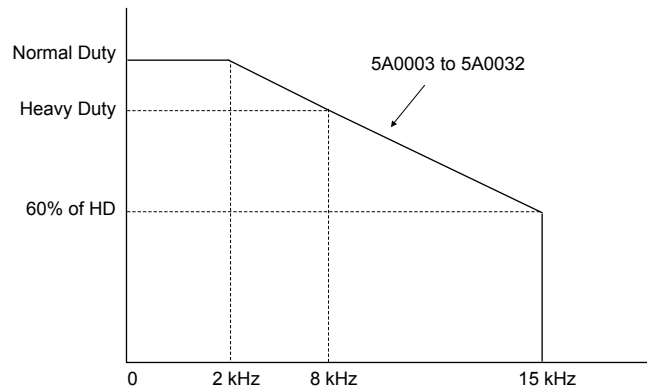

Figure A.8 Carrier Frequency Derating (Models 5A0003 to 5A0032)

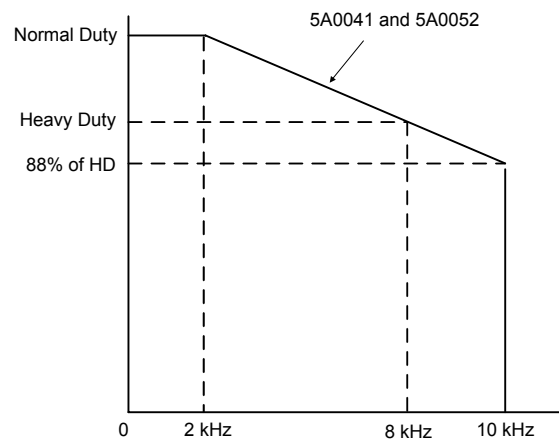

Figure A.9 Carrier Frequency Derating (Models 5A0041 and 5A0052)

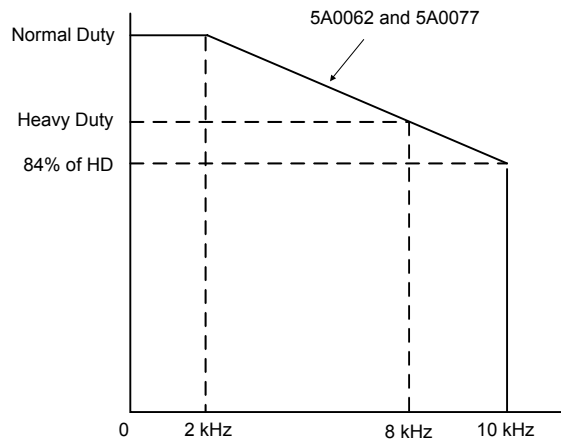

Figure A.10 Carrier Frequency Derating (Models 5A0062 and 5A0077)

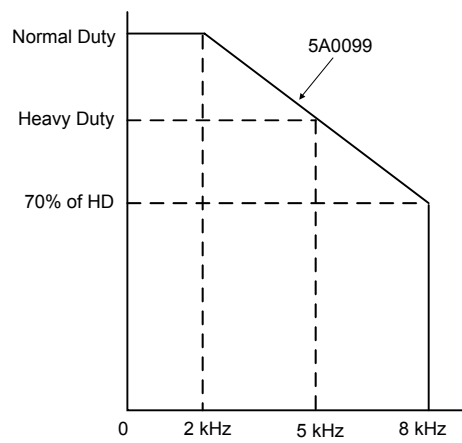

Figure A.11 Carrier Frequency Derating (Model 5A0099)

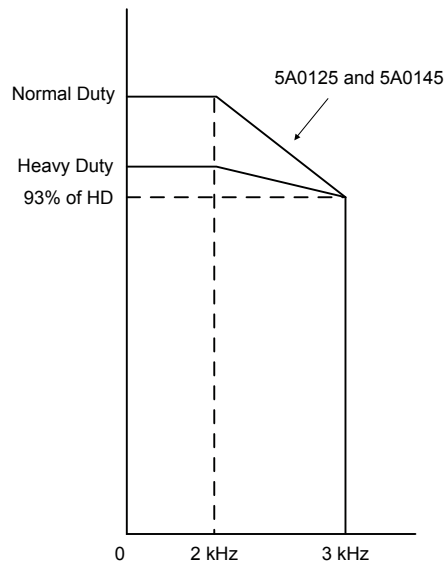

Figure A.12 Carrier Frequency Derating (Models 5A0125 and 5A0145)

A.5 Drive Derating Data

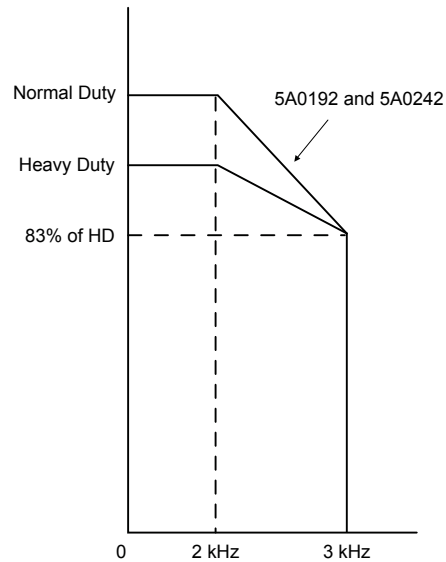

Figure A.13 Carrier Frequency Derating (Models 5A0192 and 5A0242)

◆ Temperature Derating

To ensure the maximum performance life, the drive output current must be derated as shown in [Figure A.14](#) when the drive is installed in areas with high ambient temperature or if drives are mounted side-by-side in a cabinet. In order to ensure reliable drive overload protection, set parameters L8-12 and L8-35 according to the installation conditions.

■ Parameter Settings

No.	Name	Description	Range	Def.
L8-12	Ambient Temperature Setting	Adjust the drive overload (oL2) protection level when the drive is installed in an environment that exceeds its ambient temperature rating.	-10 to +50	+40 °C
L8-35	Installation Method Selection	0: IP00/Open-Chassis Enclosure 1: Side-by-Side Mounting 2: IP20/NEMA Type 1 Enclosure 3: Finless Drive or External Heatsink Installation	0 to 3	</>

<1> Default setting is determined by drive model.

Setting 0: (Models 2A0250 to 2A0415 and 4A0208 to 4A1200)

Setting 2: (Models 2A0004 to 2A0211, 4A0002 to 4A0165, and 5A0003 to 5A0242).

IP00/Open-Chassis Enclosure

Drive operation between -10 °C and +50 °C allows 100% continuous current without derating.

Side-by-Side Mounting

Drive operation between -10 °C and +30 °C allows 100% continuous current without derating. Operation between +30 °C and +50 °C requires output current derating.

IP20/NEMA Type 1 Enclosure

Drive operation between -10 °C and +40 °C allows 100% continuous current without derating. Operation between +40 °C and +50 °C requires output current derating.

External Heatsink Installation, Finless Drive

Drive operation between -10 °C and +40 °C allows 100% continuous current without derating. Operation between +40 °C and +50 °C requires output current derating.

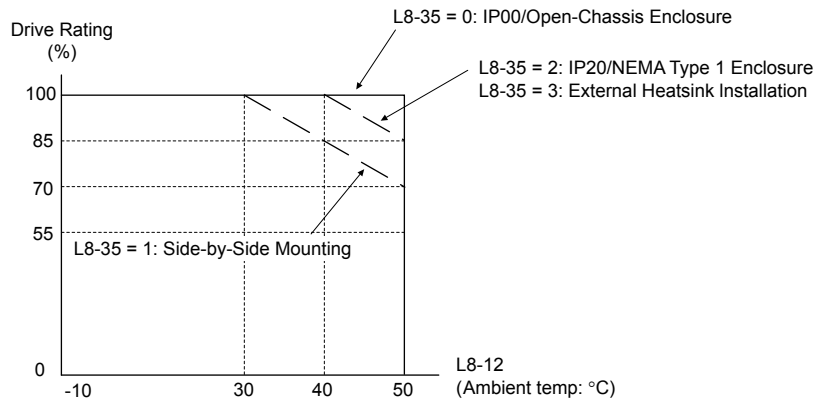

Figure A.14 Ambient Temperature and Installation Method Derating

◆ Altitude Derating

The drive standard ratings are valid for installation altitudes up to 1000 m. For installations from 1000 m to 3000 m, the drive rated voltage and the rated output current must be derated for 0.2% per 100 m.

This Page Intentionally Blank

Appendix: B

Parameter List

This appendix contains a full listing of all parameters and settings available in the drive.

B.1	UNDERSTANDING PARAMETER DESCRIPTIONS.....	490
B.2	PARAMETER GROUPS.....	491
B.3	A: INITIALIZATION PARAMETERS.....	493
B.4	B: APPLICATION.....	495
B.5	C: TUNING.....	503
B.6	D: REFERENCES.....	509
B.7	E: MOTOR PARAMETERS.....	514
B.8	F: OPTIONS.....	520
B.9	H PARAMETERS: MULTI-FUNCTION TERMINALS.....	528
B.10	L: PROTECTION FUNCTION.....	541
B.11	N: SPECIAL ADJUSTMENT.....	550
B.12	O: OPERATOR-RELATED SETTINGS.....	554
B.13	DRIVEWORKSEZ PARAMETERS.....	557
B.14	T: MOTOR TUNING.....	558
B.15	U: MONITORS.....	562
B.16	CONTROL MODE DEPENDENT PARAMETER DEFAULT VALUES.....	571
B.17	V/F PATTERN DEFAULT VALUES.....	575
B.18	DEFAULTS BY DRIVE MODEL AND DUTY RATING ND/HD.....	577
B.19	PARAMETERS CHANGED BY MOTOR CODE SELECTION.....	594

B.1 Understanding Parameter Descriptions

◆ Control Modes, Symbols, and Terms

The table below lists terms and symbols used in this section to indicate which parameters are available in which control modes.

Note: Refer to *Control Mode Selection on page 32* for detailed instructions on each control mode.

Table B.1 Symbols and Icons Used in Parameter Descriptions

Symbol	Description
	Parameter is available in all control modes.
	Parameter is available when operating the drive with V/f Control.
	Parameter is available when operating the drive with V/f with PG Control.
	Parameter is available when operating the drive with Open Loop Vector.
	Parameter is available when operating the drive with Closed Loop Vector.
	Parameter is available when operating the drive with Open Loop Vector for PM motors. <99>
	Parameter is available when operating the drive with Advanced Open Loop Vector for PM motors. <99>
	Parameter is available when operating the drive with Closed Loop Vector for PM motors. <99>
	Parameter is NOT available when operating the drive in the control mode.
	Parameter can be changed during run.
Motor 2	Refers to a second motor when the drive is operating two motors. Switch between these motors using the multi-function input terminals.

<99> PM motor control modes are not available on 600 V class drives, models 5A□□□□.

B.2 Parameter Groups

Parameter Group	Name	Page	Parameter Group	Name	Page
A1	Initialization Parameters	493	H2 <1>	Multi-Function Digital Outputs	533
A2	User Parameters	494	H3 <1>	Multi-Function Analog Inputs	536
b1	Operation Mode Selection	495	H4	Multi-Function Analog Outputs	538
b2	DC Injection Braking and Short Circuit Braking	496	H5	MEMOBUS/Modbus Serial Communication	539
b3 <1>	Speed Search	497	H6	Pulse Train Input/Output	540
b4	Timer Function	498	L1 <1>	Motor Protection	541
b5	PID Control	499	L2	Momentary Power Loss Ride-Thru	542
b6	Dwell Function	501	L3 <1>	Stall Prevention	543
b7	Droop Control	501	L4	Speed Detection	545
b8	Energy Saving	501	L5	Fault Restart	545
b9	Zero Servo	502	L6	Torque Detection	546
C1	Acceleration and Deceleration Times	503	L7	Torque Limit	547
C2	S-Curve Characteristics	504	L8 <1>	Drive Protection	547
C3 <1>	Slip Compensation	504	n1	Hunting Prevention	550
C4	Torque Compensation	505	n2	Speed Feedback Detection Control (AFR) Tuning	550
C5	Automatic Speed Regulator (ASR)	506	n3	High Slip Braking (HSB) and Overexcitation Braking	550
C6 <1>	Carrier Frequency	508	n5	Feed Forward Control	551
d1	Frequency Reference	509	n6	Online Tuning	552
d2	Frequency Upper/Lower Limits	510	n8 <1>	PM Motor Control Tuning	552
d3	Jump Frequency	511	o1	Digital Operator Display Selection	554
d4	Frequency Reference Hold and Up/Down 2 Function	511	o2	Digital Operator Keypad Functions	554
d5	Torque Control	512	o3	Copy Function	555
d6	Field Weakening and Field Forcing	513	o4	Maintenance Monitor Settings	555
d7	Offset Frequency	513	q	DriveWorksEZ Parameters	557
E1	V/f Pattern for Motor 1	514	r	DriveWorksEZ Connection Parameters	557
E2 <1>	Motor 1 Parameters	515	T1	Induction Motor Auto-Tuning	558
E3	V/f Pattern for Motor 2	516	T2	PM Motor Auto-Tuning	559
E4 <1>	Motor 2 Parameters	517	T3	ASR and Inertia Tuning	561
E5	PM Motor Settings	518	U1 <1>	Operation Status Monitors	562
F1	PG Speed Control Card (PG-B3/PG-X3)	520	U2 <1>	Fault Trace	564
F2	Analog Input Card (AI-A3)	522	U3	Fault History	566
F3	Digital Input Card (DI-A3)	522	U4 <1>	Maintenance Monitors	566
F4	Analog Monitor Card (AO-A3)	523	U5	PID Monitors	568
F5	Digital Output Card (DO-A3)	523	U6	Operation Status Monitors	569
F6, F7	Communication Option Card	524	U8	DriveWorksEZ Monitors	570
H1	Multi-Function Digital Inputs	528			

<1> Specifications differ for models 4A0930 and 4A1200. *Refer to Parameter Differences for Drive Models 4A0930 and 4A1200 on page 492* for details.

◆ Parameter Differences for Drive Models 4A0930 and 4A1200



Table B.2 Overview of Parameter Differences by Parameter Group

Parameter Group	Name	Differences
b3	Speed Search	Depends on b3-04 setting. Refer to b3: Speed Search on page 497 for details.
C3	Slip Compensation	<ul style="list-style-type: none"> Depends on C3-05 setting. Refer to C3: Slip Compensation on page 504 for details. C3-16 to C3-18 are available.
C6	Carrier Frequency	<ul style="list-style-type: none"> Defaults and setting ranges differ for C6-02, C6-03, and C6-04. Refer to C6: Carrier Frequency on page 508 for details. C6-09 is not available.
E2	Motor 1 Parameters	Setting units differ for E2-05. Refer to E2: Motor 1 Parameters on page 515 for details.
E4	Motor 2 Parameters	Setting units differ for E4-05. Refer to E4: Motor 2 Parameters on page 517 for details.
H2	Multi-Function Digital Outputs	H2-□□ cannot be set to D, 4E, or 4F.
H3	Multi-Function Digital Inputs	H3-□□ = 17 is available.
L1	Motor Protection	L1-15 to L1-20 are available. Refer to L1: Motor Protection on page 541 for details.
L3	Stall Prevention	<ul style="list-style-type: none"> Refer to L3: Stall Prevention on page 543 for details. L3-04 is not available.
L8	Drive Protection	<ul style="list-style-type: none"> L8-01 and L8-55 are not available. Setting range differs for L8-27. Refer to L8: Drive Protection on page 547 for details. L8-78 is available on models 4A0930 and 4A1200 only.
n8	PM Motor Control Timing	n8-84 is available.
U1	Operation Status Monitors	<ul style="list-style-type: none"> Setting units differ for U1-03. Refer to U1: Operation Status Monitors on page 562 for details. U1-29 is available.
U2	Fault Trace	<ul style="list-style-type: none"> Setting units differ for U2-05. Refer to U2: Fault Trace on page 564 for details. U2-27 and U2-28 are available.
U4	Maintenance Monitors	<ul style="list-style-type: none"> Setting units differ for U4-13. Refer to U4: Maintenance Monitors on page 566 for details. U4-32, U4-37, U4-38, and U4-39 are available.

B.3 A: Initialization Parameters

The A parameter group creates the operating environment for the drive. This includes the parameter Access Level, Motor Control Method, Password, User Parameters and more.

◆ A1: Initialization

No. (Addr. Hex)	Name	Description	Values	Page
A1-00 (100)  <1>	Language Selection	All Modes 0: English 1: Japanese 2: German 3: French 4: Italian 5: Spanish 6: Portuguese 7: Chinese	Default: 0 Range: 0 to 7	156
A1-01 (101)  <2>	Access Level Selection	All Modes 0: View and set A1-01 and A1-04. U□-□□ parameters can also be viewed. 1: User Parameters (access to a set of parameters selected by the user, A2-01 to A2-32) 2: Advanced Access (access to view and set all parameters)	Default: 2 Range: 0 to 2	156
A1-02 (102) <1>	Control Method Selection	All Modes 0: V/f Control 1: V/f Control with PG 2: Open Loop Vector Control 3: Closed Loop Vector Control 5: Open Loop Vector Control for PM 6: Advanced Open Loop Vector Control for PM 7: Closed Loop Vector Control for PM Note: PM motor control modes are not available on 600 V class drives, models 5A□□□□.	Default: 2 Range: 0 to 3; 5 to 7	157
A1-03 (103)	Initialize Parameters	All Modes 0: No initialization 1110: User Initialize (parameter values must be stored using parameter o2-03) 2220: 2-Wire initialization 3330: 3-Wire initialization 5550: oPE04 error reset	Default: 0 Range: 0 to 3330; 5550	157
A1-04 (104)	Password	All Modes When the value set into A1-04 does not match the value set into A1-05, parameters A1-01 through A1-03, A1-06, and A2-01 through A2-33 cannot be changed.	Default: 0000 Min.: 0000 Max.: 9999	158
A1-05 (105)	Password Setting	All Modes When the value set into A1-04 does not match the value set into A1-05, parameters A1-01 through A1-03, A1-06, and A2-01 through A2-33 cannot be changed.	Default: 0000 Min.: 0000 Max.: 9999	158
A1-06 (127)	Application Preset	All Modes 0: General-purpose 1: Water supply pump 2: Conveyor 3: Exhaust fan 4: HVAC fan 5: Air compressor	Default: 0 Range: 0 to 5	160
A1-07 (128)	DriveWorksEZ Function Selection	All Modes 0: DWEZ Disabled 1: DWEZ Enabled 2: Digital input (enabled when H1-□□ = 9F)	Default: 0 Range: 0 to 2	161

<1> Parameter setting value is not reset to the default value when the drive is initialized.

<2> Default setting value is dependent on the Application Preset selected with parameter A1-06.

◆ A2: User Parameters

No. (Addr. Hex)	Name	Description	Values	Page
A2-01 to A2-32 (106 to 125)	User Parameters 1 to 32	<p>All Modes</p> <p>Recently edited parameters are listed here. The user can also select parameters to appear here for quicker access.</p>	Default: <1> Range: b1-01 to o4-13	<i>161</i>
A2-33 (126)	User Parameter Automatic Selection	<p>All Modes</p> <p>0: Parameters A2-01 to A2-32 are reserved for the user to create a list of User Parameters. 1: Save history of recently viewed parameters. Recently edited parameters will be saved to A2-17 through A2-32 for quicker access.</p>	Default: 1 <2> Range: 0, 1	<i>161</i>

<1> Default setting value is dependent on the Application Preset selected with parameter A1-06.

<2> Default setting value is dependent on parameter A1-06. Default is 0 when A1-06 = 0, and 1 when A1-06 ≠ 0.

B.4 b: Application

Application parameters configure the source of the Run command, DC Injection Braking, Speed Search, timer functions, PID control, the Dwell function, Energy Savings, and a variety of other application-related settings.

◆ b1: Operation Mode Selection

No. (Addr. Hex)	Name	Description	Values	Page
b1-01 (180)	Frequency Reference Selection 1	All Modes 0: Digital operator 1: Analog input terminals 2: MEMOBUS/Modbus communications 3: Option PCB 4: Pulse input (terminal RP)	Default: 1 Range: 0 to 4	162
b1-02 (181)	Run Command Selection 1	All Modes 0: Digital operator 1: Digital input terminals 2: MEMOBUS/Modbus communications 3: Option PCB	Default: 1 Range: 0 to 3	163
b1-03 (182)	Stopping Method Selection	All Modes 0: Ramp to stop 1: Coast to stop 2: DC Injection Braking to stop 3: Coast with timer	Default: 0 Range: 0 to 3 <1>	164
b1-04 (183)	Reverse Operation Selection	All Modes 0: Reverse enabled. 1: Reverse disabled.	Default: 0 Range: 0, 1	167
b1-05 (184)	Action Selection below Minimum Output Frequency	<input type="radio"/> V/f <input type="radio"/> V/f w PG <input type="radio"/> OLV <input checked="" type="radio"/> CLV <input type="radio"/> OLV/PM <input type="radio"/> AOLV/PM <input checked="" type="radio"/> CLV/PM 0: Operates according to frequency reference (E1-09 is disabled). 1: Output shuts off (coast to stop if less than E1-09). 2: Operates according to E1-09 (frequency reference set to E1-09). 3: Zero speed (frequency reference becomes zero when less than E1-09).	Default: 0 Range: 0 to 3	167
b1-06 (185)	Digital Input Reading	All Modes 0: Input status is read once and processed immediately (for quicker response) 1: Input is read twice and processed only if the status is the same in both readings (robust against noisy signals)	Default: 1 Range: 0, 1	168
b1-07 (186)	LOCAL/REMOTE Run Selection	All Modes 0: An external Run command must be cycled at the new source in order to be activated. 1: An external Run command at the new source is accepted immediately.	Default: 0 Range: 0, 1	169
b1-08 (187)	Run Command Selection in Programming Mode	All Modes 0: Run command is not accepted while in Programming Mode. 1: Run command is accepted while in Programming Mode. 2: Prohibit entering Programming Mode during run.	Default: 0 Range: 0 to 2	169
b1-14 (1C3)	Phase Order Selection	<input checked="" type="radio"/> V/f <input type="radio"/> V/f w PG <input type="radio"/> OLV <input checked="" type="radio"/> CLV <input type="radio"/> OLV/PM <input type="radio"/> AOLV/PM <input type="radio"/> CLV/PM 0: Standard 1: Switch phase order (reverses the direction of the motor)	Default: 0 Range: 0, 1	169
b1-15 (1C4)	Frequency Reference Selection 2	All Modes Enabled when an input terminal set for “External reference” (H1-□□ = 2) closes. 0: Digital operator 1: Terminals (analog input terminals) 2: MEMOBUS/Modbus communications 3: Option card 4: Pulse train input	Default: 0 Range: 0 to 4	169

B.4 b: Application

No. (Addr. Hex)	Name	Description	Values	Page
b1-16 (1C5)	Run Command Selection 2	All Modes Enabled when a terminal set for “External reference” (H1-□□ = 2) closes. 0: Digital operator 1: Digital input terminals 2: MEMOBUS/Modbus communications 3: Option card	Default: 0 Range: 0 to 3	170
b1-17 (1C6)	Run Command at Power Up	All Modes 0: Disregarded. A new Run command must be issued after power up. 1: Allowed. Motor will start immediately after power up if a Run command is already enabled.	Default: 0 Range: 0, 1	170

<1> Setting range is 0, 1, 3 in CLV, OLV/PM, AOLV/PM, and CLV/PM control modes.

◆ b2: DC Injection Braking and Short Circuit Braking

No. (Addr. Hex)	Name	Description	Values	Page
b2-01 (189)	DC Injection Braking Start Frequency	All Modes Sets the frequency at which DC Injection Braking starts when “Ramp to stop” (b1-03 = 0) is selected.	Default: <1> Min.: 0.0 Hz Max.: 10.0 Hz	170
b2-02 (18A)	DC Injection Braking Current	<input type="radio"/> V/f <input type="radio"/> V/f w PG <input checked="" type="radio"/> OLV <input type="radio"/> CLV <input type="radio"/> OLV/PM <input type="radio"/> AOLV/PM <input type="radio"/> CLV/PM Sets the DC Injection Braking current as a percentage of the drive rated current.	Default: 50% Min.: 0 Max.: 100	171
b2-03 (18B)	DC Injection Braking Time at Start	<input type="radio"/> V/f <input type="radio"/> V/f w PG <input checked="" type="radio"/> OLV <input type="radio"/> CLV <input type="radio"/> OLV/PM <input type="radio"/> AOLV/PM <input type="radio"/> CLV/PM Sets DC Injection Braking (Zero Speed Control when in CLV and CLV/PM) time at start. Disabled when set to 0.00 seconds.	Default: 0.00 s Min.: 0.00 Max.: 10.00	171
b2-04 (18C)	DC Injection Braking Time at Stop	<input type="radio"/> V/f <input type="radio"/> V/f w PG <input checked="" type="radio"/> OLV <input type="radio"/> CLV <input type="radio"/> OLV/PM <input type="radio"/> AOLV/PM <input type="radio"/> CLV/PM Sets DC Injection Braking (Zero Speed Control when in CLV and CLV/PM) time at stop.	Default: <1> Min.: 0.00 s Max.: 10.00 s	171
b2-08 (190)	Magnetic Flux Compensation Value	<input type="radio"/> V/f <input type="radio"/> V/f w PG <input checked="" type="radio"/> OLV <input type="radio"/> CLV <input type="radio"/> OLV/PM <input type="radio"/> AOLV/PM <input type="radio"/> CLV/PM Sets the magnetic flux compensation as a percentage of the no-load current value (E2-03).	Default: 0% Min.: 0 Max.: 1000	172
b2-12 (1BA)	Short Circuit Brake Time at Start	<input type="radio"/> V/f <input type="radio"/> V/f w PG <input type="radio"/> OLV <input type="radio"/> CLV <input checked="" type="radio"/> OLV/PM <input checked="" type="radio"/> AOLV/PM <input type="radio"/> CLV/PM Sets the time for Short Circuit Braking operation at start. <2>	Default: 0.00 s Min.: 0.00 Max.: 25.50	172
b2-13 (1BB)	Short Circuit Brake Time at Stop	<input type="radio"/> V/f <input type="radio"/> V/f w PG <input type="radio"/> OLV <input type="radio"/> CLV <input checked="" type="radio"/> OLV/PM <input checked="" type="radio"/> AOLV/PM <input type="radio"/> CLV/PM Sets the Short Circuit Braking operation time at stop. <2>	Default: 0.50 s Min.: 0.00 Max.: 25.50	172
b2-18 (177)	Short Circuit Braking Current	<input type="radio"/> V/f <input type="radio"/> V/f w PG <input type="radio"/> OLV <input type="radio"/> CLV <input checked="" type="radio"/> OLV/PM <input checked="" type="radio"/> AOLV/PM <input type="radio"/> CLV/PM Determines the current level for Short Circuit Braking. Set as a percentage of the motor rated current.	Default: 100.0% Min.: 0.0 Max.: 200.0	172

<1> Default setting is determined by parameter A1-02, Control Method Selection.

<2> A coasting motor may require a braking resistor circuit to bring the motor to a stop in the required time.

◆ b3: Speed Search

No. (Addr Hex.)	Name	Description	Values	Page
b3-01 (191)	Speed Search Selection at Start	<p><input checked="" type="radio"/> V/f <input checked="" type="radio"/> V/f w PG <input checked="" type="radio"/> OLV <input type="radio"/> CLV</p> <p><input type="radio"/> OLV/PM <input type="radio"/> AOLV/PM <input type="radio"/> CLV/PM</p> <p>0: Disabled 1: Enabled</p>	Default: </> Range: 0, 1	176
b3-02 (192)	Speed Search Deactivation Current	<p><input checked="" type="radio"/> V/f <input type="radio"/> V/f w PG <input checked="" type="radio"/> OLV <input type="radio"/> CLV</p> <p><input type="radio"/> OLV/PM <input type="radio"/> AOLV/PM <input type="radio"/> CLV/PM</p> <p>Sets the current level at which the speed is assumed to be detected and Speed Search is ended. Set as a percentage of the drive rated current.</p>	Default: </> Min.: 0% Max.: 200%	176
b3-03 (193)	Speed Search Deceleration Time	<p><input checked="" type="radio"/> V/f <input type="radio"/> V/f w PG <input checked="" type="radio"/> OLV <input type="radio"/> CLV</p> <p><input type="radio"/> OLV/PM <input type="radio"/> AOLV/PM <input type="radio"/> CLV/PM</p> <p>Sets output frequency reduction time during Speed Search.</p>	Default: 2.0 s Min.: 0.1 Max.: 10.0	176
b3-04 (194)	V/f Gain during Speed Search	<p><input checked="" type="radio"/> V/f <input type="radio"/> V/f w PG <input checked="" type="radio"/> OLV <input type="radio"/> CLV</p> <p><input type="radio"/> OLV/PM <input type="radio"/> AOLV/PM <input type="radio"/> CLV/PM</p> <p>Determines how much to lower the V/f ratio during Speed Search. Output voltage during Speed Search equals the V/f setting multiplied by b3-04.</p> <p>Note: Available control mode for parameter b3-04 varies by drive model: Models 2A0004 to 2A0415, 4A0002 to 4A0675, and 5A0003 to 5A0242: Available when A1-02 = 0 Models 4A0930 and 4A1200: Available when A1-02 = 0, 2</p>	Default: </> Min.: 10% Max.: 100%	176
b3-05 (195)	Speed Search Delay Time	<p>All Modes</p> <p>When using an external contactor on the output side, b3-05 delays executing Speed Search after a momentary power loss to allow time for the contactor to close.</p>	Default: 0.2 s Min.: 0.0 Max.: 100.0	176
b3-06 (196)	Output Current 1 during Speed Search	<p><input checked="" type="radio"/> V/f <input checked="" type="radio"/> V/f w PG <input checked="" type="radio"/> OLV <input type="radio"/> CLV</p> <p><input type="radio"/> OLV/PM <input type="radio"/> AOLV/PM <input type="radio"/> CLV/PM</p> <p>Sets the current injected to the motor at the beginning of Speed Estimation Speed Search. Set as a coefficient for the motor rated current.</p>	Default: </> Min.: 0.0 Max.: 2.0	176
b3-07 (197)	Output Current 2 during Speed Search (Speed Estimation Type)	<p><input checked="" type="radio"/> V/f <input checked="" type="radio"/> V/f w PG <input checked="" type="radio"/> OLV <input type="radio"/> CLV</p> <p><input type="radio"/> OLV/PM <input type="radio"/> AOLV/PM <input type="radio"/> CLV/PM</p> <p>Sets the amount of output current during Speed Estimation Speed Search as a coefficient for the no-load current.</p> <p>Note: This parameter is only available in models 4A0930 and 4A1200.</p>	Default: </> Min.: 0.0 Max.: 5.0	177
b3-08 (198)	Current Control Gain during Speed Search (Speed Estimation Type)	<p><input checked="" type="radio"/> V/f <input type="radio"/> V/f w PG <input checked="" type="radio"/> OLV <input type="radio"/> CLV</p> <p><input type="radio"/> OLV/PM <input type="radio"/> AOLV/PM <input type="radio"/> CLV/PM</p> <p>Sets the proportional gain for the current controller during Speed Search.</p> <p>Note: This parameter is only available in models 4A0930 and 4A1200.</p>	Default: </> Min.: 0.00 Max.: 6.00	177
b3-10 (19A)	Speed Search Detection Compensation Gain	<p><input checked="" type="radio"/> V/f <input type="radio"/> V/f w PG <input checked="" type="radio"/> OLV <input type="radio"/> CLV</p> <p><input type="radio"/> OLV/PM <input type="radio"/> AOLV/PM <input type="radio"/> CLV/PM</p> <p>Sets the gain which is applied to the speed detected by Speed Estimation Speed Search before the motor is reaccelerated. Increase this setting if ov occurs when performing Speed Search after a relatively long period of baseblock.</p>	Default: 1.05 Min.: 1.00 Max.: 1.20	177
b3-12 (19C)	Minimum Current Detection Level during Speed Search	<p><input checked="" type="radio"/> V/f <input checked="" type="radio"/> V/f w PG <input checked="" type="radio"/> OLV <input type="radio"/> CLV</p> <p><input type="radio"/> OLV/PM <input type="radio"/> AOLV/PM <input type="radio"/> CLV/PM</p> <p>Sets the minimum current detection level during Speed Search.</p> <p>Note: This parameter is only available in models 4A0930 and 4A1200.</p>	Default: 6.0 Min.: 2.0 Max.: 10.0	177
b3-14 (19E)	Bi-Directional Speed Search Selection	<p><input checked="" type="radio"/> V/f <input checked="" type="radio"/> V/f w PG <input checked="" type="radio"/> OLV <input type="radio"/> CLV</p> <p><input type="radio"/> OLV/PM <input type="radio"/> AOLV/PM <input type="radio"/> CLV/PM</p> <p>0: Disabled (uses the direction of the frequency reference) 1: Enabled (drive detects which way the motor is rotating)</p>	Default: </> Range: 0, 1	177

B.4 b: Application

No. (Addr Hex.)	Name	Description	Values	Page
b3-17 (1F0)	Speed Search Restart Current Level	<p>V/f <input type="checkbox"/> V/f w PG <input type="checkbox"/> OLV <input checked="" type="checkbox"/> CLV <input type="checkbox"/></p> <p><input type="checkbox"/> OLV/PM <input type="checkbox"/> AOLV/PM <input type="checkbox"/> CLV/PM <input type="checkbox"/></p> <p>Sets the Speed Search restart current level as a percentage of the drive rated current.</p>	Default: 150% Min.: 0 Max.: 200	177
b3-18 (1F1)	Speed Search Restart Detection Time	<p>V/f <input type="checkbox"/> V/f w PG <input type="checkbox"/> OLV <input checked="" type="checkbox"/> CLV <input type="checkbox"/></p> <p><input type="checkbox"/> OLV/PM <input type="checkbox"/> AOLV/PM <input type="checkbox"/> CLV/PM <input type="checkbox"/></p> <p>Sets the time to detect Speed Search restart.</p>	Default: 0.10 s Min.: 0.00 Max.: 1.00	178
b3-19 (1F2)	Number of Speed Search Restarts	<p>V/f <input type="checkbox"/> V/f w PG <input type="checkbox"/> OLV <input checked="" type="checkbox"/> CLV <input type="checkbox"/></p> <p><input type="checkbox"/> OLV/PM <input type="checkbox"/> AOLV/PM <input type="checkbox"/> CLV/PM <input type="checkbox"/></p> <p>Sets the number of times the drive can attempt to restart when performing Speed Search.</p>	Default: 3 Min.: 0 Max.: 10	178
b3-24 (1C0)	Speed Search Method Selection	<p>V/f <input type="checkbox"/> V/f w PG <input type="checkbox"/> OLV <input checked="" type="checkbox"/> CLV <input type="checkbox"/></p> <p><input type="checkbox"/> OLV/PM <input type="checkbox"/> AOLV/PM <input type="checkbox"/> CLV/PM <input type="checkbox"/></p> <p>0: Current Detection 1: Speed Estimation</p>	Default: 0 Range: 0, 1	178
b3-25 (1C8)	Speed Search Wait Time	<p>V/f <input type="checkbox"/> V/f w PG <input type="checkbox"/> OLV <input checked="" type="checkbox"/> CLV <input type="checkbox"/></p> <p><input type="checkbox"/> OLV/PM <input type="checkbox"/> AOLV/PM <input type="checkbox"/> CLV/PM <input type="checkbox"/></p> <p>Sets the time the drive must wait between each Speed Search restart attempt.</p>	Default: 0.5 s Min.: 0.0 Max.: 30.0	178
b3-26 (1C7)	Direction Determining Level	<p>V/f <input type="checkbox"/> V/f w PG <input type="checkbox"/> OLV <input checked="" type="checkbox"/> CLV <input type="checkbox"/></p> <p><input type="checkbox"/> OLV/PM <input type="checkbox"/> AOLV/PM <input type="checkbox"/> CLV/PM <input type="checkbox"/></p> <p>Sets the level that determines the direction of motor rotation.</p> <p>Note: This parameter is only available in models 4A0930 and 4A1200.</p>	Default: <2> Min.: 40 Max.: 60000	178
b3-27 (1C9)	Start Speed Search Select	<p>V/f <input type="checkbox"/> V/f w PG <input type="checkbox"/> OLV <input checked="" type="checkbox"/> CLV <input checked="" type="checkbox"/></p> <p><input type="checkbox"/> OLV/PM <input type="checkbox"/> AOLV/PM <input type="checkbox"/> CLV/PM <input type="checkbox"/></p> <p>Selects a condition to activate Speed Search Selection at Start (b3-01) or External Speed Search Command 1 or 2 from the multi-function input. 0: Triggered when a Run command is issued (normal). 1: Triggered when an external baseblock is released.</p>	Default: 0 Range: 0, 1	178









<1> Default setting is determined by parameter A1-02, Control Method Selection.

<2> Default setting is dependent on parameter o2-04, Drive Model Selection.



◆ b4: Timer Function

No. (Addr. Hex.)	Name	Description	Values	Page
b4-01 (1A3)	Timer Function On-Delay Time	<p>All Modes</p> <p>Sets the on-delay and off-delay times for a digital timer output (H2-□□=12).</p>	Default: 0.0 s Min.: 0.0 Max.: 3000.0	178
b4-02 (1A4)	Timer Function Off-Delay Time	<p>The output is triggered by a digital input programmed to H1-□□=18).</p>	Default: 0.0 s Min.: 0.0 Max.: 3000.0	178

◆ b5: PID Control

No. (Addr. Hex)	Name	Description	Values	Page
b5-01 (1A5)	PID Function Setting	All Modes 0: Disabled 1: Enabled (PID output becomes output frequency reference, deviation D controlled) 2: Enabled (PID output becomes output frequency reference, feedback D controlled) 3: Enabled (PID output added to frequency reference, deviation D controlled) 4: Enabled (PID output added to frequency reference, feedback D controlled)	Default: 0 Range: 0 to 4	182
b5-02 (1A6) 	Proportional Gain Setting (P)	All Modes Sets the proportional gain of the PID controller.	Default: 1.00 Min.: 0.00 Max.: 25.00	182
b5-03 (1A7) 	Integral Time Setting (I)	All Modes Sets the integral time for the PID controller.	Default: 1.0 s Min.: 0.0 Max.: 360.0	182
b5-04 (1A8) 	Integral Limit Setting	All Modes Sets the maximum output possible from the integrator as a percentage of the maximum output frequency.	Default: 100.0% Min.: 0.0 Max.: 100.0	182
b5-05 (1A9) 	Derivative Time (D)	All Modes Sets D control derivative time.	Default: 0.00 s Min.: 0.00 Max.: 10.00	182
b5-06 (1AA) 	PID Output Limit	All Modes Sets the maximum output possible from the entire PID controller as a percentage of the maximum output frequency.	Default: 100.0% Min.: 0.0 Max.: 100.0	182
b5-07 (1AB) 	PID Offset Adjustment	All Modes Applies an offset to the PID controller output. Set as a percentage of the maximum output frequency.	Default: 0.0% Min.: -100.0 Max.: 100.0	183
b5-08 (1AC) 	PID Primary Delay Time Constant	All Modes Sets a low pass filter time constant on the output of the PID controller.	Default: 0.00 s Min.: 0.00 Max.: 10.00	183
b5-09 (1AD)	PID Output Level Selection	All Modes 0: Normal output (direct acting) 1: Reverse output (reverse acting)	Default: 0 Range: 0, 1	183
b5-10 (1AE) 	PID Output Gain Setting	All Modes Sets the gain applied to the PID output. Note: Parameter setting cannot be changed when the drive is operating the motor in models 4A0930 and 4A1200.	Default: 1.00 Min.: 0.00 Max.: 25.00	183
b5-11 (1AF)	PID Output Reverse Selection	All Modes 0: Negative PID output triggers zero limit. 1: Rotation direction reverses with negative PID output. Note: When using setting 1, make sure reverse operation is permitted by b1-04.	Default: 0 Range: 0, 1	183
b5-12 (1B0)	PID Feedback Loss Detection Selection	All Modes 0: No fault. Digital output only. 1: Fault detection. Alarm output, drive continues operation. 2: Fault detection. Fault output, drive output is shut off. 3: No fault. Digital output only. No fault detection when PID control is disabled. 4: Fault detection. Alarm is triggered and drive continues to run. Fault detection even when PID is disabled. 5: Fault detection. Drive output shuts off. No fault detection when PID control is disabled.	Default: 0 Range: 0 to 5	184
b5-13 (1B1)	PID Feedback Loss Detection Level	All Modes Sets the PID feedback loss detection level as a percentage of the maximum output frequency.	Default: 0% Min.: 0 Max.: 100	184

B.4 b: Application

No. (Addr. Hex)	Name	Description	Values	Page
b5-14 (1B2)	PID Feedback Loss Detection Time	All Modes Sets a delay time for PID feedback loss.	Default: 1.0 s Min.: 0.0 Max.: 25.5	185
b5-15 (1B3)	PID Sleep Function Start Level	All Modes Sets the frequency level that triggers the sleep function.	Default: <1> Min.: 0.0 Hz Max.: 400.0 Hz	185
b5-16 (1B4)	PID Sleep Delay Time	All Modes Sets a delay time before the sleep function is triggered.	Default: 0.0 s Min.: 0.0 Max.: 25.5	185
b5-17 (1B5)	PID Accel/Decel Time	All Modes Sets the acceleration and deceleration time to PID setpoint.	Default: 0.0 s Min.: 0.0 Max.: 6000.0	186
b5-18 (1DC)	PID Setpoint Selection	All Modes 0: Disabled 1: Enabled	Default: 0 Range: 0, 1	186
b5-19 (1DD) 	PID Setpoint Value	All Modes Sets the PID target value when b5-18 = 1. Set as a percentage of the maximum output frequency. Note: Parameter setting cannot be changed when the drive is operating the motor in models 4A0930 and 4A1200.	Default: 0.00% Min.: 0.00 Max.: 100.00	186
b5-20 (1E2)	PID Setpoint Scaling	All Modes 0: 0.01 Hz units 1: 0.01% units (100% = max output frequency) 2: r/min (number of motor poles must entered) 3: User-set (set scaling to b5-38 and b5-39)	Default: 1 Range: 0 to 3	186
b5-34 (19F) 	PID Output Lower Limit	All Modes Sets the minimum output possible from the PID controller as a percentage of the maximum output frequency.	Default: 0.00% Min.: -100.00 Max.: 100.00	186
b5-35 (1A0) 	PID Input Limit	All Modes Limits the PID control input (deviation signal) as a percentage of the maximum output frequency. Acts as a bipolar limit.	Default: 1000.0% Min.: 0.0 Max.: 1000.0	187
b5-36 (1A1)	PID Feedback High Detection Level	All Modes Sets the PID feedback high detection level as a percentage of the maximum output frequency.	Default: 100% Min.: 0 Max.: 100	185
b5-37 (1A2)	PID Feedback High Detection Time	All Modes Sets the PID feedback high level detection delay time.	Default: 1.0 s Min.: 0.0 Max.: 25.5	185
b5-38 (1FE)	PID Setpoint User Display	All Modes Sets the display value of U5-01 and U5-04 when the maximum frequency is output.	Default: <2> Min.: 1 Max.: 60000	187
b5-39 (1FF)	PID Setpoint Display Digits	All Modes 0: No decimal places 1: One decimal place 2: Two decimal places 3: Three decimal places	Default: <2> Range: 0 to 3	187
b5-40 (17F)	Frequency Reference Monitor Content during PID	All Modes 0: Display the frequency reference (U1-01) after PID compensation has been added. 1: Display the frequency reference (U1-01) before PID compensation has been added.	Default: 0 Range: 0, 1	187
b5-47 <3> (17D)	Reverse Operation Selection 2 by PID Output	All Modes Reverse operation selection when b5-01 = 3 or 4. 0: Zero limit when PID output is a negative value. 1: Reverse operation when PID output is a negative value (Zero limit if the reverse operation is prohibited by b1-04).	Default: 1 Range: 0, 1	187

<1> Default setting is determined by parameter A1-02, Control Method Selection.

<2> Default setting is dependent on parameter b5-20, PID Setpoint Scaling.

<3> Available in drive software versions 1015 and later.

◆ b6: Dwell Function

No. (Addr. Hex)	Name	Description	Values	Page
b6-01 (1B6)	Dwell Reference at Start	All Modes Parameters b6-01 and b6-02 set the frequency to hold and the time to maintain that frequency at start.	Default: 0.0 Hz Min.: 0.0 Max.: 400.0	189
b6-02 (1B7)	Dwell Time at Start		Default: 0.0 s Min.: 0.0 Max.: 10.0	189
b6-03 (1B8)	Dwell Reference at Stop	All Modes Parameters b6-03 and b6-04 set the frequency to hold and the time to maintain that frequency at stop.	Default: 0.0 Hz Min.: 0.0 Max.: 400.0	189
b6-04 (1B9)	Dwell Time at Stop		Default: 0.0 s Min.: 0.0 Max.: 10.0	189

◆ b7: Droop Control

No. (Addr. Hex)	Name	Description	Values	Page
b7-01 (1CA) ↕ RUN	Droop Control Gain	V/f V/f w PG OLV CLV OLV/PM AOLV/PM CLV/PM Sets the speed reduction gain applied at a torque reference of 100%. Set as a percentage of motor base speed.	Default: 0.0% Min.: 0.0 Max.: 100.0	189
b7-02 (1CB) ↕ RUN	Droop Control Delay Time	V/f V/f w PG OLV CLV OLV/PM AOLV/PM CLV/PM Adjusts the responsiveness of Droop Control.	Default: 0.05 s Min.: 0.03 Max.: 2.00	190
b7-03 (17E) <1>	Droop Control Limit Selection	V/f V/f w PG OLV CLV OLV/PM AOLV/PM CLV/PM 0: Disabled 1: Enabled	Default: 1 Range: 0, 1	190

<1> Available in drive software versions 1015 and later.

◆ b8: Energy Saving

No. (Addr. Hex)	Name	Description	Values	Page
b8-01 (1CC)	Energy Saving Control Selection	V/f V/f w PG OLV CLV OLV/PM AOLV/PM CLV/PM 0: Disabled 1: Enabled	Default: <1> Range: 0, 1	190
b8-02 (1CD) ↕ RUN	Energy Saving Gain	V/f V/f w PG OLV CLV OLV/PM AOLV/PM CLV/PM Sets the gain used for Energy Saving.	Default: <1> Min.: 0.0 Max.: 10.0	190
b8-03 (1CE) ↕ RUN	Energy Saving Control Filter Time Constant	V/f V/f w PG OLV CLV OLV/PM AOLV/PM CLV/PM Sets a time constant for Energy Saving.	Default: <2> Min.: 0.00 s Max.: 10.00 s	191
b8-04 (1CF)	Energy Saving Coefficient Value	V/f V/f w PG OLV CLV OLV/PM AOLV/PM CLV/PM Determines the level of maximum motor efficiency. Setting range is 0.0 to 2000.0 for drives 3.7 kW and smaller. The display resolution depends on the rated output power of the drive after the Drive Duty has been set in parameter C6-01. <i>Refer to Model Number and Nameplate Check on page 35.</i>	Default: <3> <4> Min.: 0.00 Max.: 655.00	191

B.4 b: Application

No. (Addr. Hex)	Name	Description	Values	Page
b8-05 (1D0)	Power Detection Filter Time	<input checked="" type="radio"/> V/f <input checked="" type="radio"/> V/f w PG <input type="radio"/> OLV <input type="radio"/> CLV <input type="radio"/> OLV/PM <input type="radio"/> AOLV/PM <input type="radio"/> CLV/PM Sets a time constant filter for output power detection.	Default: 20 ms Min.: 0 Max.: 2000	191
b8-06 (1D1)	Search Operation Voltage Limit	<input checked="" type="radio"/> V/f <input checked="" type="radio"/> V/f w PG <input type="radio"/> OLV <input type="radio"/> CLV <input type="radio"/> OLV/PM <input type="radio"/> AOLV/PM <input type="radio"/> CLV/PM Sets the limit for the voltage search operation as a percentage of the motor rated voltage.	Default: 0% Min.: 0 Max.: 100	191
b8-16 (1F8) <5>	Energy Saving Parameter (Ki) for PM Motors	<input type="radio"/> V/f <input type="radio"/> V/f w PG <input type="radio"/> OLV <input type="radio"/> CLV <input type="radio"/> OLV/PM <input checked="" type="radio"/> AOLV/PM <input checked="" type="radio"/> CLV/PM Coefficient to adjust torque linearity. Set to the Ki value on the motor nameplate. When parameter E5-01, Motor Code Selection, is set to 1□□□ or 2□□□, the automatically calculated value will be set. This set value cannot be changed.	Default: 1.00 Min.: 0.00 Max.: 2.00	191
b8-17 (1F9) <5>	Energy Saving Parameter (Kt) for PM Motors	<input type="radio"/> V/f <input type="radio"/> V/f w PG <input type="radio"/> OLV <input type="radio"/> CLV <input type="radio"/> OLV/PM <input checked="" type="radio"/> AOLV/PM <input checked="" type="radio"/> CLV/PM Coefficient to adjust torque linearity. Set to the Kt value on the motor nameplate. When parameter E5-01, Motor Code Selection, is set to 1□□□ or 2□□□, the automatically calculated value will be set. This set value cannot be changed.	Default: 1.00 Min.: 0.00 Max.: 2.00	191

<1> Default setting is determined by parameter A1-02, Control Method Selection.

<2> Default setting is dependent on parameters A1-02, Control Method Selection, C6-01, Drive Duty Selection, and o2-04, Drive Model Selection.

<3> Default setting is dependent on parameter o2-04, Drive Model Selection, and C6-01, Drive Duty Selection.

<4> Parameter value changes automatically if E2-11 is manually changed or changed by Auto-Tuning.

<5> Available in drive software versions 1015 and later.

◆ b9: Zero Servo

No. (Addr. Hex)	Name	Description	Values	Page
b9-01 (1DA)	Zero Servo Gain	<input type="radio"/> V/f <input type="radio"/> V/f w PG <input type="radio"/> OLV <input checked="" type="radio"/> CLV <input type="radio"/> OLV/PM <input type="radio"/> AOLV/PM <input checked="" type="radio"/> CLV/PM Sets the position loop gain for the Zero Servo function.	Default: 5 Min.: 0 Max.: 100	192
b9-02 (1DB)	Zero Servo Completion Width	<input type="radio"/> V/f <input type="radio"/> V/f w PG <input type="radio"/> OLV <input checked="" type="radio"/> CLV <input type="radio"/> OLV/PM <input type="radio"/> AOLV/PM <input checked="" type="radio"/> CLV/PM Sets the range to trigger an output terminal set for “Zero Servo Complete” during Zero Servo operation.	Default: 10 Min.: 0 Max.: 16383	192

B.5 C: Tuning

C parameters are used to adjust the acceleration and deceleration times, S-curves, torque compensation, and carrier frequency selections.

◆ C1: Acceleration and Deceleration Times

No. (Addr. Hex)	Name	Description	Values	Page
C1-01 (200) 	Acceleration Time 1	All Modes Sets the time to accelerate from 0 to maximum frequency.	Default: 10.0 s Min.: 0.0 Max.: 6000.0 </>	193
C1-02 (201) 	Deceleration Time 1	All Modes Sets the time to decelerate from maximum frequency to 0.	Default: 10.0 s Min.: 0.0 Max.: 6000.0 </>	193
C1-03 (202) 	Acceleration Time 2	All Modes Sets the time to accelerate from 0 to maximum frequency.	Default: 10.0 s Min.: 0.0 Max.: 6000.0 </>	193
C1-04 (203) 	Deceleration Time 2	All Modes Sets the time to decelerate from maximum frequency to 0.	Default: 10.0 s Min.: 0.0 Max.: 6000.0 </>	193
C1-05 (204) 	Acceleration Time 3 (Motor 2 Accel Time 1)	All Modes Sets the time to accelerate from 0 to maximum frequency.	Default: 10.0 s Min.: 0.0 Max.: 6000.0 </>	193
C1-06 (205) 	Deceleration Time 3 (Motor 2 Decel Time 1)	All Modes Sets the time to decelerate from maximum frequency to 0.	Default: 10.0 s Min.: 0.0 Max.: 6000.0 </>	193
C1-07 (206) 	Acceleration Time 4 (Motor 2 Accel Time 2)	All Modes Sets the time to accelerate from 0 to maximum frequency.	Default: 10.0 s Min.: 0.0 Max.: 6000.0 </>	193
C1-08 (207) 	Deceleration Time 4 (Motor 2 Decel Time 2)	All Modes Sets the time to decelerate from maximum frequency to 0.	Default: 10.0 s Min.: 0.0 Max.: 6000.0 </>	193
C1-09 (208) 	Fast Stop Time	All Modes Sets the time for the Fast Stop function. Note: Parameter setting cannot be changed when the drive is operating the motor in models 4A0930 and 4A1200.	Default: 10.0 s Min.: 0.0 Max.: 6000.0 </>	194
C1-10 (209)	Accel/Decel Time Setting Units	All Modes 0: 0.01 s (0.00 to 600.00 s) 1: 0.1 s (0.0 to 6000.0 s)	Default: 1 Range: 0, 1	195
C1-11 (20A)	Accel/Decel Time Switching Frequency	All Modes Sets the frequency to switch between accel/decel time settings	Default: 0.0 Hz Min.: 0.0 Max.: 400.0	194

<1> Setting range value is dependent on parameter C1-10, Accel/Decel Time Setting Units. When C1-10 = 0 (units of 0.01 seconds), the setting range becomes 0.00 to 600.00 seconds.

◆ C2: S-Curve Characteristics

No. (Addr. Hex)	Name	Description	Values	Page
C2-01 (20B)	S-Curve Characteristic at Accel Start	<p>All Modes</p> <p>The S-curve can be controlled at the four points shown below.</p>	Default: 0.20 s <input type="text"/> Min.: 0.00 Max.: 10.00	195
C2-02 (20C)	S-Curve Characteristic at Accel End		Default: 0.20 s Min.: 0.00 Max.: 10.00	195
C2-03 (20D)	S-Curve Characteristic at Decel Start		Default: 0.20 s Min.: 0.00 Max.: 10.00	195
C2-04 (20E)	S-Curve Characteristic at Decel End		Default: 0.00 s Min.: 0.00 Max.: 10.00	195

<1> Default setting is determined by parameter A1-02, Control Method Selection.

◆ C3: Slip Compensation

No. (Addr. Hex)	Name	Description	Values	Page
C3-01 (20F) 	Slip Compensation Gain	<p><input checked="" type="radio"/> V/f <input type="radio"/> V/f w PG <input checked="" type="radio"/> OLV <input checked="" type="radio"/> CLV</p> <p><input type="radio"/> OLV/PM <input type="radio"/> AOLV/PM <input type="radio"/> CLV/PM</p> <p>Sets the gain for the motor slip compensation function used for motor 1.</p>	Default: <input type="text"/> Min.: 0.0 Max.: 2.5	195
C3-02 (210) 	Slip Compensation Primary Delay Time	<p><input checked="" type="radio"/> V/f <input type="radio"/> V/f w PG <input checked="" type="radio"/> OLV <input type="radio"/> CLV</p> <p><input type="radio"/> OLV/PM <input type="radio"/> AOLV/PM <input type="radio"/> CLV/PM</p> <p>Adjusts the slip compensation function delay time used for motor 1.</p>	Default: <input type="text"/> Min.: 0 ms Max.: 10000 ms	196
C3-03 (211)	Slip Compensation Limit	<p><input checked="" type="radio"/> V/f <input type="radio"/> V/f w PG <input checked="" type="radio"/> OLV <input type="radio"/> CLV</p> <p><input type="radio"/> OLV/PM <input type="radio"/> AOLV/PM <input type="radio"/> CLV/PM</p> <p>Sets an upper limit for the slip compensation function as a percentage of motor rated slip for motor 1 (E2-02).</p>	Default: 200% Min.: 0 Max.: 250	196
C3-04 (212)	Slip Compensation Selection during Regeneration	<p><input checked="" type="radio"/> V/f <input type="radio"/> V/f w PG <input checked="" type="radio"/> OLV <input type="radio"/> CLV</p> <p><input type="radio"/> OLV/PM <input type="radio"/> AOLV/PM <input type="radio"/> CLV/PM</p> <p>0: Disabled. 1: Enabled above 6 Hz. 2: Enabled whenever slip compensation is possible.</p>	Default: 0 Range: 0 to 2	196
C3-05 (213)	Output Voltage Limit Operation Selection	<p><input type="radio"/> V/f <input type="radio"/> V/f w PG <input checked="" type="radio"/> OLV <input checked="" type="radio"/> CLV</p> <p><input type="radio"/> OLV/PM <input type="radio"/> AOLV/PM <input type="radio"/> CLV/PM</p> <p>0: Disabled. 1: Enabled. Automatically decreases motor flux when output voltage saturation is reached.</p> <p>Note: Available control mode for parameter C3-05 varies by drive model: Models 2A0004 to 2A0415, 4A0002 to 4A0675, and 5A0003 to 5A0242: Available when A1-02 = 0,1. Models 4A0930 and 4A1200: Available when A1-02 = 2, 3, 6, 7.</p>	Default: 0 Range: 0, 1	197
C3-16 (261)	Output Voltage Limit Operation Start Level (Percentage Modulation)	<p><input type="radio"/> V/f <input type="radio"/> V/f w PG <input checked="" type="radio"/> OLV <input checked="" type="radio"/> CLV</p> <p><input type="radio"/> OLV/PM <input type="radio"/> AOLV/PM <input type="radio"/> CLV/PM</p> <p>Sets the output voltage limit operation start level (percentage modulation) when C3-05 is enabled.</p> <p>Note: This parameter is only available in models 4A0930 and 4A1200.</p>	Default: 85.0% Min.: 70.0 Max.: 90.0	197
C3-17 (262)	Maximum Output Voltage Limit Level (Percentage Modulation)	<p><input type="radio"/> V/f <input type="radio"/> V/f w PG <input checked="" type="radio"/> OLV <input checked="" type="radio"/> CLV</p> <p><input type="radio"/> OLV/PM <input type="radio"/> AOLV/PM <input type="radio"/> CLV/PM</p> <p>Sets the output voltage limit operation determined by C3-18 (percentage modulation) when C3-05 is enabled.</p> <p>Note: This parameter is only available in models 4A0930 and 4A1200.</p>	Default: 90.0% Min.: 85.0 Max.: 100.0	197

No. (Addr. Hex)	Name	Description	Values	Page
C3-18 (263)	Output Voltage Limit Level	<input type="radio"/> V/f <input type="radio"/> V/f w PG <input checked="" type="radio"/> OLV <input checked="" type="radio"/> CLV <input type="radio"/> OLV/PM <input type="radio"/> AOLV/PM <input type="radio"/> CLV/PM Sets the maximum percentage of output voltage reduction when C3-05 is enabled. Note: This parameter is only available in models 4A0930 and 4A1200.	Default: 90.0% Min.: 30.0 Max.: 100.0	197
C3-21 (33E) 	Motor 2 Slip Compensation Gain	<input type="radio"/> V/f <input type="radio"/> V/f w PG <input checked="" type="radio"/> OLV <input checked="" type="radio"/> CLV <input type="radio"/> OLV/PM <input type="radio"/> AOLV/PM <input type="radio"/> CLV/PM Sets the slip compensation gain used for motor 2.	Default: <2> Min.: 0.0 Max.: 2.5	197
C3-22 (241) 	Motor 2 Slip Compensation Primary Delay Time	<input type="radio"/> V/f <input type="radio"/> V/f w PG <input checked="" type="radio"/> OLV <input type="radio"/> CLV <input type="radio"/> OLV/PM <input type="radio"/> AOLV/PM <input type="radio"/> CLV/PM Sets the slip compensation delay time used for motor 2.	Default: <2> Min.: 0 ms Max.: 10000 ms	197
C3-23 (242)	Motor 2 Slip Compensation Limit	<input type="radio"/> V/f <input type="radio"/> V/f w PG <input checked="" type="radio"/> OLV <input type="radio"/> CLV <input type="radio"/> OLV/PM <input type="radio"/> AOLV/PM <input type="radio"/> CLV/PM Sets the upper limit for the slip compensation function for motor 2. Set as a percentage of the motor rated slip (E4-02).	Default: 200% Min.: 0 Max.: 250	198
C3-24 (243)	Motor 2 Slip Compensation Selection During Regeneration	<input type="radio"/> V/f <input type="radio"/> V/f w PG <input checked="" type="radio"/> OLV <input type="radio"/> CLV <input type="radio"/> OLV/PM <input type="radio"/> AOLV/PM <input type="radio"/> CLV/PM 0: Disabled. 1: Enabled above 6 Hz. 2: Enabled whenever slip compensation is possible.	Default: 0 Range: 0 to 2	198

<1> Default setting is determined by parameter A1-02, Control Method Selection.

<2> Default setting is determined by parameter E3-01, Motor 2 Control Mode Selection.

◆ C4: Torque Compensation

No. (Addr. Hex)	Name	Description	Values	Page
C4-01 (215) 	Torque Compensation Gain	<input type="radio"/> V/f <input type="radio"/> V/f w PG <input checked="" type="radio"/> OLV <input type="radio"/> CLV <input type="radio"/> OLV/PM <input type="radio"/> AOLV/PM <input type="radio"/> CLV/PM Sets the gain for the automatic torque (voltage) boost function and helps to produce better starting torque. Used for motor 1.	Default: <1> Min.: 0.00 Max.: 2.50	198
C4-02 (216) 	Torque Compensation Primary Delay Time 1	<input type="radio"/> V/f <input type="radio"/> V/f w PG <input checked="" type="radio"/> OLV <input type="radio"/> CLV <input type="radio"/> OLV/PM <input type="radio"/> AOLV/PM <input type="radio"/> CLV/PM Sets the torque compensation filter time.	Default: <2> Min.: 0 ms Max.: 60000 ms	199
C4-03 (217)	Torque Compensation at Forward Start	<input type="radio"/> V/f <input type="radio"/> V/f w PG <input checked="" type="radio"/> OLV <input type="radio"/> CLV <input type="radio"/> OLV/PM <input type="radio"/> AOLV/PM <input type="radio"/> CLV/PM Sets torque compensation at forward start as a percentage of motor torque.	Default: 0.0% Min.: 0.0 Max.: 200.0	199
C4-04 (218)	Torque Compensation at Reverse Start	<input type="radio"/> V/f <input type="radio"/> V/f w PG <input checked="" type="radio"/> OLV <input type="radio"/> CLV <input type="radio"/> OLV/PM <input type="radio"/> AOLV/PM <input type="radio"/> CLV/PM Sets torque compensation at reverse start as a percentage of motor torque.	Default: 0.0% Min.: -200.0 Max.: 0.0	199
C4-05 (219)	Torque Compensation Time Constant	<input type="radio"/> V/f <input type="radio"/> V/f w PG <input checked="" type="radio"/> OLV <input type="radio"/> CLV <input type="radio"/> OLV/PM <input type="radio"/> AOLV/PM <input type="radio"/> CLV/PM Sets the time constant for torque compensation at forward start and reverse start (C4-03 and C4-04).	Default: 10 ms Min.: 0 Max.: 200	199
C4-06 (21A)	Torque Compensation Primary Delay Time 2	<input type="radio"/> V/f <input type="radio"/> V/f w PG <input checked="" type="radio"/> OLV <input type="radio"/> CLV <input type="radio"/> OLV/PM <input type="radio"/> AOLV/PM <input type="radio"/> CLV/PM Sets the torque compensation time 2.	Default: 150 ms Min.: 0 Max.: 10000	199
C4-07 (341) 	Motor 2 Torque Compensation Gain	<input type="radio"/> V/f <input type="radio"/> V/f w PG <input checked="" type="radio"/> OLV <input type="radio"/> CLV <input type="radio"/> OLV/PM <input type="radio"/> AOLV/PM <input type="radio"/> CLV/PM Sets the torque compensation gain used for motor 2.	Default: 1.00 Min.: 0.00 Max.: 2.50	199

<1> Default setting is determined by parameter A1-02, Control Method Selection.

<2> Default setting is determined by parameters A1-02, Control Method Selection, and o2-04, Drive Model Selection.

◆ C5: Automatic Speed Regulator (ASR)

No. (Addr. Hex)	Name	Description	Values	Page
C5-01 (21B) 	ASR Proportional Gain 1	<input type="button" value="V/f"/> <input checked="" type="button" value="V/f w PG"/> <input type="button" value="OLV"/> <input checked="" type="button" value="CLV"/> <input type="button" value="OLV/PM"/> <input checked="" type="button" value="AOLV/PM"/> <input checked="" type="button" value="CLV/PM"/> Sets the proportional gain of the speed control loop (ASR).	Default: <> Min.: 0.00 Max.: 300.00 <>	202
C5-02 (21C) 	ASR Integral Time 1	<input type="button" value="V/f"/> <input checked="" type="button" value="V/f w PG"/> <input type="button" value="OLV"/> <input checked="" type="button" value="CLV"/> <input type="button" value="OLV/PM"/> <input checked="" type="button" value="AOLV/PM"/> <input checked="" type="button" value="CLV/PM"/> Sets the integral time of the speed control loop (ASR).	Default: <> Min.: 0.000 s Max.: 10.000 s	202
C5-03 (21D) 	ASR Proportional Gain 2	<input type="button" value="V/f"/> <input checked="" type="button" value="V/f w PG"/> <input type="button" value="OLV"/> <input checked="" type="button" value="CLV"/> <input type="button" value="OLV/PM"/> <input checked="" type="button" value="AOLV/PM"/> <input checked="" type="button" value="CLV/PM"/> Sets the speed control gain 2 of the speed control loop (ASR).	Default: <> Min.: 0.00 Max.: 300.00 <>	202
C5-04 (21E) 	ASR Integral Time 2	<input type="button" value="V/f"/> <input checked="" type="button" value="V/f w PG"/> <input type="button" value="OLV"/> <input checked="" type="button" value="CLV"/> <input type="button" value="OLV/PM"/> <input checked="" type="button" value="AOLV/PM"/> <input checked="" type="button" value="CLV/PM"/> Sets the integral time 2 of the speed control loop (ASR).	Default: <> Min.: 0.000 s Max.: 10.000 s	202
C5-05 (21F)	ASR Limit	<input type="button" value="V/f"/> <input checked="" type="button" value="V/f w PG"/> <input type="button" value="OLV"/> <input type="button" value="CLV"/> <input type="button" value="OLV/PM"/> <input type="button" value="AOLV/PM"/> <input type="button" value="CLV/PM"/> Sets the upper limit for the speed control loop (ASR) as a percentage of the maximum output frequency (E1-04).	Default: 5.0% Min.: 0.0 Max.: 20.0	203
C5-06 (220)	ASR Primary Delay Time Constant	<input type="button" value="V/f"/> <input type="button" value="V/f w PG"/> <input type="button" value="OLV"/> <input checked="" type="button" value="CLV"/> <input type="button" value="OLV/PM"/> <input checked="" type="button" value="AOLV/PM"/> <input checked="" type="button" value="CLV/PM"/> Sets the filter time constant for the time from the speed loop to the torque command output.	Default: <> Min.: 0.000 s Max.: 0.500 s	203
C5-07 (221)	ASR Gain Switching Frequency	<input type="button" value="V/f"/> <input type="button" value="V/f w PG"/> <input type="button" value="OLV"/> <input checked="" type="button" value="CLV"/> <input type="button" value="OLV/PM"/> <input checked="" type="button" value="AOLV/PM"/> <input checked="" type="button" value="CLV/PM"/> Sets the frequency for switching between proportional gain 1, 2 and integral time 1, 2.	Default: 0.0 Hz Min.: 0.0 Max.: 400.0	203
C5-08 (222)	ASR Integral Limit	<input type="button" value="V/f"/> <input type="button" value="V/f w PG"/> <input type="button" value="OLV"/> <input checked="" type="button" value="CLV"/> <input type="button" value="OLV/PM"/> <input checked="" type="button" value="AOLV/PM"/> <input checked="" type="button" value="CLV/PM"/> Sets the ASR integral upper limit as a percentage of rated load torque.	Default: 400% Min.: 0 Max.: 400	203
C5-12 (386)	Integral Operation during Accel/Decel	<input type="button" value="V/f"/> <input checked="" type="button" value="V/f w PG"/> <input type="button" value="OLV"/> <input type="button" value="CLV"/> <input type="button" value="OLV/PM"/> <input type="button" value="AOLV/PM"/> <input type="button" value="CLV/PM"/> 0: Disabled. Integral functions are enabled only during constant speed. 1: Enabled. Integral functions are always enabled, during accel/decel and during constant speed.	Default: 0 Range: 0, 1	203
C5-17 (276)	Motor Inertia	<input type="button" value="V/f"/> <input type="button" value="V/f w PG"/> <input type="button" value="OLV"/> <input checked="" type="button" value="CLV"/> <input type="button" value="OLV/PM"/> <input type="button" value="AOLV/PM"/> <input checked="" type="button" value="CLV/PM"/> Sets the motor inertia. This value is automatically set during ASR or Inertia Auto-Tuning.	Default: <> <> Min.: 0.0001 kgm ² Max.: 600.00 kgm ²	203
C5-18 (277)	Load Inertia Ratio	<input type="button" value="V/f"/> <input type="button" value="V/f w PG"/> <input type="button" value="OLV"/> <input checked="" type="button" value="CLV"/> <input type="button" value="OLV/PM"/> <input type="button" value="AOLV/PM"/> <input checked="" type="button" value="CLV/PM"/> Sets the ratio between the motor and load inertia. This value is automatically set during ASR or Inertia Auto-Tuning.	Default: 1.0 Min.: 0.0 Max.: 6000.0	203
C5-21 (356) 	Motor 2 ASR Proportional Gain 1	<input type="button" value="V/f"/> <input checked="" type="button" value="V/f w PG"/> <input type="button" value="OLV"/> <input checked="" type="button" value="CLV"/> <input type="button" value="OLV/PM"/> <input type="button" value="AOLV/PM"/> <input type="button" value="CLV/PM"/> Sets the proportional gain of the speed control loop (ASR) for motor 2.	Default: <> Min.: 0.00 Max.: 300.00 <>	204
C5-22 (357) 	Motor 2 ASR Integral Time 1	<input type="button" value="V/f"/> <input checked="" type="button" value="V/f w PG"/> <input type="button" value="OLV"/> <input checked="" type="button" value="CLV"/> <input type="button" value="OLV/PM"/> <input type="button" value="AOLV/PM"/> <input type="button" value="CLV/PM"/> Sets the integral time of the speed control loop (ASR) for motor 2.	Default: <> Min.: 0.000 s Max.: 10.000 s	204
C5-23 (358) 	Motor 2 ASR Proportional Gain 2	<input type="button" value="V/f"/> <input checked="" type="button" value="V/f w PG"/> <input type="button" value="OLV"/> <input checked="" type="button" value="CLV"/> <input type="button" value="OLV/PM"/> <input type="button" value="AOLV/PM"/> <input type="button" value="CLV/PM"/> Sets the speed control gain 2 of the speed control loop (ASR) for motor 2.	Default: <> Min.: 0.00 Max.: 300.00 <>	204

No. (Addr. Hex)	Name	Description	Values	Page
C5-24 (359) RUN	Motor 2 ASR Integral Time 2	<p>V/f V/f w PG OLV CLV</p> <p>OLV/PM AOLV/PM CLV/PM</p> <p>Sets the integral time 2 of the speed control loop (ASR) for motor 2.</p>	Default: <5> Min.: 0.000 s Max.: 10.000 s	204
C5-25 (35A)	Motor 2 ASR Limit	<p>V/f V/f w PG OLV CLV</p> <p>OLV/PM AOLV/PM CLV/PM</p> <p>Sets the upper limit for the speed control loop (ASR) for motor 2 as a percentage of the maximum output frequency (E3-04).</p>	Default: 5.0% Min.: 0.0 Max.: 20.0	204
C5-26 (35B)	Motor 2 ASR Primary Delay Time Constant	<p>V/f V/f w PG OLV CLV</p> <p>OLV/PM AOLV/PM CLV/PM</p> <p>Sets the filter time constant for the time from the speed loop to the torque command output used for motor 2.</p>	Default: <5> Min.: 0.000 s Max.: 0.500 s	204
C5-27 (35C)	Motor 2 ASR Gain Switching Frequency	<p>V/f V/f w PG OLV CLV</p> <p>OLV/PM AOLV/PM CLV/PM</p> <p>Sets the frequency for motor 2 used to switch between proportional gain 1 and 2, and between the integral time 1 and 2.</p>	Default: 0.0 Hz Min.: 0.0 Max.: 400.0	204
C5-28 (35D)	Motor 2 ASR Integral Limit	<p>V/f V/f w PG OLV CLV</p> <p>OLV/PM AOLV/PM CLV/PM</p> <p>Sets the ASR integral upper limit for motor 2 as a percentage of rated load torque.</p>	Default: 400% Min.: 0 Max.: 400	204
C5-32 (361)	Integral Operation during Accel/Decel for Motor 2	<p>V/f V/f w PG OLV CLV</p> <p>OLV/PM AOLV/PM CLV/PM</p> <p>0: Disabled. Integral functions for motor 2 are enabled only during constant speed. 1: Enabled. Integral functions are always enabled for motor 2, during accel/ decel and during constant speed.</p>	Default: 0 Range: 0, 1	204
C5-37 (278)	Motor 2 Inertia	<p>V/f V/f w PG OLV CLV</p> <p>OLV/PM AOLV/PM CLV/PM</p> <p>Sets the inertia of motor 2 alone without the load. This value is automatically set during ASR or Inertia Auto-Tuning.</p>	Default: <3> <4> Min.: 0.0001 kgm ² Max.: 600.00 kgm ²	205
C5-38 (279)	Motor 2 Load Inertia Ratio	<p>V/f V/f w PG OLV CLV</p> <p>OLV/PM AOLV/PM CLV/PM</p> <p>Sets the ratio between the motor 2 and machine inertia. This value is automatically set during ASR or Inertia Auto-Tuning.</p>	Default: 1.0 Min.: 0.0 Max.: 6000.0	205
C5-39 (30D)	Motor 2 ASR Primary Delay Time Constant 2	<p>V/f V/f w PG OLV CLV</p> <p>OLV/PM AOLV/PM CLV/PM</p> <p>Sets the filter time constant in seconds for the time from the speed loop to the torque reference output when the Power KEB Ride-Thru is enabled (L2-29 = 1).</p> <p>Note: This parameter is not available in models 4A0930 and 4A1200.</p>	Default: 0.000 s Min.: 0.000 Max.: 0.500	205

<1> Default setting is determined by parameter A1-02, Control Method Selection.

<2> The setting range is 1.00 to 300.00 in CLV and AOLV/PM control modes.

<3> Default setting is dependent on parameter E5-01, Motor Code Selection.

<4> Default setting is dependent on parameters C6-01, Drive Duty Selection, and o2-04, Drive Model Selection.

<5> Default setting is determined by parameter E3-01, Motor 2 Control Mode Selection.

◆ C6: Carrier Frequency

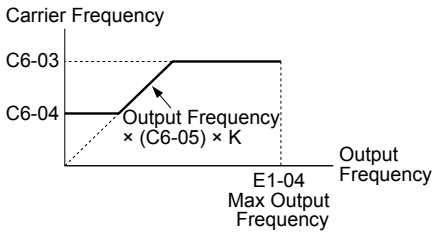







No. (Addr. Hex)	Name	Description	Values	Page
C6-01 (223)	Drive Duty Selection	<p>All Modes</p> <p>0: Heavy Duty (HD) Overload capability: 150% of drive rated Heavy Duty current for 60 s Default Carrier Frequency: 2 kHz</p> <p>1: Normal Duty (ND) Overload capability: 120% of drive rated Normal Duty current for 60 s Default Carrier Frequency: 2 kHz Swing PWM</p>	Default: 1 Range: 0, 1	205
C6-02 (224)	Carrier Frequency Selection	<p>All Modes</p> <p>1: 2.0 kHz 2: 5.0 kHz (4.0 kHz) 3: 8.0 kHz (6.0 kHz) 4: 10.0 kHz (8.0 kHz) 5: 12.5 kHz (10.0 kHz) 6: 15.0 kHz (12.0 kHz) 7: Swing PWM1 (Audible sound 1) 8: Swing PWM2 (Audible sound 2) 9: Swing PWM3 (Audible sound 3) A: Swing PWM4 (Audible sound 4) B to E: No setting possible F: User-defined (determined by C6-03 through C6-05)</p> <p>Note:</p> <ol style="list-style-type: none"> The available settings are 1, 2, and F for models 4A0930 and 4A1200. The value in parenthesis indicates the carrier frequency for AOLV/PM. 	Default: <1> Range: 1 to 9; A, F	206
C6-03 (225)	Carrier Frequency Upper Limit	<p>All Modes</p> <p>Note: C6-04 and C6-05 are available only in V/f and V/f w/PG control modes.</p>	Default: <2> Min.: 1.0 kHz Max.: 15.0 kHz	206
C6-04 (226)	Carrier Frequency Lower Limit	<p>Determines the upper and lower limits for the carrier frequency. In OLV, C6-03 determines the upper limit of the carrier frequency.</p>	Default: <2> Min.: 1.0 kHz Max.: 15.0 kHz	206
C6-05 (227)	Carrier Frequency Proportional Gain	 <p>Note: The setting range is 1.0 to 5.0 kHz for models 4A0930 and 4A1200.</p>	Default: <2> Min.: 0 Max.: 99	206
C6-09 (22B)	Carrier Frequency during Rotational Auto-Tuning	<p> <input type="radio"/> V/f <input type="radio"/> V/f w PG <input checked="" type="radio"/> OLV <input checked="" type="radio"/> CLV <input type="radio"/> OLV/PM <input type="radio"/> AOLV/PM <input checked="" type="radio"/> CLV/PM </p> <p>0: Carrier Frequency = 5 kHz 1: Setting value for C6-03</p> <p>Note: This parameter is not available in models 4A0930 and 4A1200.</p>	Default: 0 Range: 0, 1	207

<1> Default setting value is dependent on parameters A1-02, Control Method Selection, C6-01, Drive Duty Selection, and o2-04, Drive Model Selection.
 <2> Default setting value is dependent on parameter C6-02, Carrier Frequency Selection.









B.6 d: References

Reference parameters set the various frequency reference values during operation.

◆ d1: Frequency Reference

No. (Addr. Hex)	Name	Description	Values	Page
d1-01 (280) 	Frequency Reference 1	<p>All Modes</p> <p>Sets the frequency reference for the drive. Setting units are determined by parameter o1-03.</p> <p>Note: The value set to o1-03 is changed to 1 and the unit is changed to percentage automatically when A1-02 is set to 6 or 7.</p>	Default: 0.00 Hz Min.: 0.00 Max.: 400.00 </> <2>	208
d1-02 (281) 	Frequency Reference 2	<p>All Modes</p> <p>Sets the frequency reference for the drive. Setting units are determined by parameter o1-03.</p> <p>Note: The value set to o1-03 is changed to 1 and the unit is changed to percentage automatically when A1-02 is set to 6 or 7.</p>	Default: 0.00 Hz Min.: 0.00 Max.: 400.00 </> <2>	208
d1-03 (282) 	Frequency Reference 3	<p>All Modes</p> <p>Sets the frequency reference for the drive. Setting units are determined by parameter o1-03.</p> <p>Note: The value set to o1-03 is changed to 1 and the unit is changed to percentage automatically when A1-02 is set to 6 or 7.</p>	Default: 0.00 Hz Min.: 0.00 Max.: 400.00 </> <2>	208
d1-04 (283) 	Frequency Reference 4	<p>All Modes</p> <p>Sets the frequency reference for the drive. Setting units are determined by parameter o1-03.</p> <p>Note: The value set to o1-03 is changed to 1 and the unit is changed to percentage automatically when A1-02 is set to 6 or 7.</p>	Default: 0.00 Hz Min.: 0.00 Max.: 400.00 </> <2>	208
d1-05 (284) 	Frequency Reference 5	<p>All Modes</p> <p>Sets the frequency reference for the drive. Setting units are determined by parameter o1-03.</p> <p>Note: The value set to o1-03 is changed to 1 and the unit is changed to percentage automatically when A1-02 is set to 6 or 7.</p>	Default: 0.00 Hz Min.: 0.00 Max.: 400.00 </> <2>	208
d1-06 (285) 	Frequency Reference 6	<p>All Modes</p> <p>Sets the frequency reference for the drive. Setting units are determined by parameter o1-03.</p> <p>Note: The value set to o1-03 is changed to 1 and the unit is changed to percentage automatically when A1-02 is set to 6 or 7.</p>	Default: 0.00 Hz Min.: 0.00 Max.: 400.00 </> <2>	208
d1-07 (286) 	Frequency Reference 7	<p>All Modes</p> <p>Sets the frequency reference for the drive. Setting units are determined by parameter o1-03.</p> <p>Note: The value set to o1-03 is changed to 1 and the unit is changed to percentage automatically when A1-02 is set to 6 or 7.</p>	Default: 0.00 Hz Min.: 0.00 Max.: 400.00 </> <2>	208
d1-08 (287) 	Frequency Reference 8	<p>All Modes</p> <p>Sets the frequency reference for the drive. Setting units are determined by parameter o1-03.</p> <p>Note: The value set to o1-03 is changed to 1 and the unit is changed to percentage automatically when A1-02 is set to 6 or 7.</p>	Default: 0.00 Hz Min.: 0.00 Max.: 400.00 </> <2>	208
d1-09 (288) 	Frequency Reference 9	<p>All Modes</p> <p>Sets the frequency reference for the drive. Setting units are determined by parameter o1-03.</p> <p>Note: The value set to o1-03 is changed to 1 and the unit is changed to percentage automatically when A1-02 is set to 6 or 7.</p>	Default: 0.00 Hz Min.: 0.00 Max.: 400.00 </> <2>	208

B.6 d: References

No. (Addr. Hex)	Name	Description	Values	Page
d1-10 (28B) 	Frequency Reference 10	All Modes Sets the frequency reference for the drive. Setting units are determined by parameter o1-03. Note: The value set to o1-03 is changed to 1 and the unit is changed to percentage automatically when A1-02 is set to 6 or 7.	Default: 0.00 Hz Min.: 0.00 Max.: 400.00 <1> <2>	208
d1-11 (28C) 	Frequency Reference 11	All Modes Sets the frequency reference for the drive. Setting units are determined by parameter o1-03. Note: The value set to o1-03 is changed to 1 and the unit is changed to percentage automatically when A1-02 is set to 6 or 7.	Default: 0.00 Hz Min.: 0.00 Max.: 400.00 <1> <2>	208
d1-12 (28D) 	Frequency Reference 12	All Modes Sets the frequency reference for the drive. Setting units are determined by parameter o1-03. Note: The value set to o1-03 is changed to 1 and the unit is changed to percentage automatically when A1-02 is set to 6 or 7.	Default: 0.00 Hz Min.: 0.00 Max.: 400.00 <1> <2>	208
d1-13 (28E) 	Frequency Reference 13	All Modes Sets the frequency reference for the drive. Setting units are determined by parameter o1-03. Note: The value set to o1-03 is changed to 1 and the unit is changed to percentage automatically when A1-02 is set to 6 or 7.	Default: 0.00 Hz Min.: 0.00 Max.: 400.00 <1> <2>	208
d1-14 (28F) 	Frequency Reference 14	All Modes Sets the frequency reference for the drive. Setting units are determined by parameter o1-03. Note: The value set to o1-03 is changed to 1 and the unit is changed to percentage automatically when A1-02 is set to 6 or 7.	Default: 0.00 Hz Min.: 0.00 Max.: 400.00 <1> <2>	208
d1-15 (290) 	Frequency Reference 15	All Modes Sets the frequency reference for the drive. Setting units are determined by parameter o1-03. Note: The value set to o1-03 is changed to 1 and the unit is changed to percentage automatically when A1-02 is set to 6 or 7.	Default: 0.00 Hz Min.: 0.00 Max.: 400.00 <1> <2>	208
d1-16 (291) 	Frequency Reference 16	All Modes Sets the frequency reference for the drive. Setting units are determined by parameter o1-03. Note: The value set to o1-03 is changed to 1 and the unit is changed to percentage automatically when A1-02 is set to 6 or 7.	Default: 0.00 Hz Min.: 0.00 Max.: 400.00 <1> <2>	208
d1-17 (292) 	Jog Frequency Reference	All Modes Sets the Jog frequency reference. Setting units are determined by parameter o1-03.	Default: 6.00 Hz Min.: 0.00 Max.: 400.00 <1> <2>	208

<1> Range upper limit is determined by parameters d2-01, Frequency Reference Upper Limit, and E1-04, Maximum Output Frequency.

<2> The setting range is 0.0 to 66.0 in AOLV/PM.

◆ d2: Frequency Upper/Lower Limits

No. (Addr. Hex.)	Name	Description	Setting	Page
d2-01 (289)	Frequency Reference Upper Limit	All Modes Sets the frequency reference upper limit as a percentage of the maximum output frequency.	Default: 100.0% Min.: 0.0 Max.: 110.0	210
d2-02 (28A)	Frequency Reference Lower Limit	All Modes Sets the frequency reference lower limit as a percentage of the maximum output frequency.	Default: 0.0% Min.: 0.0 Max.: 110.0	210
d2-03 (293)	Master Speed Reference Lower Limit	All Modes Sets the lower limit for frequency references from analog inputs as a percentage of the maximum output frequency.	Default: 0.0% Min.: 0.0 Max.: 110.0	211

◆ d3: Jump Frequency





No. (Addr. Hex)	Name	Description	Values	Page
d3-01 (294)	Jump Frequency 1	All Modes Eliminates problems with resonant vibration of the motor/machine by avoiding continuous operation in predefined frequency ranges. The drive accelerates and decelerates the motor through the prohibited frequency ranges. Setting 0.0 disables this function. Parameters must be set so that d3-01 ≥ d3-02 ≥ d3-03.	Default: <1> <2> Min.: 0.0 <2> Max.: 400.0 <2>	211
d3-02 (295)	Jump Frequency 2	All Modes Eliminates problems with resonant vibration of the motor/machine by avoiding continuous operation in predefined frequency ranges. The drive accelerates and decelerates the motor through the prohibited frequency ranges. Setting 0.0 disables this function. Parameters must be set so that d3-01 ≥ d3-02 ≥ d3-03.	Default: <1> <2> Min.: 0.0 <2> Max.: 400.0 <2>	211
d3-03 (296)	Jump Frequency 3	All Modes Eliminates problems with resonant vibration of the motor/machine by avoiding continuous operation in predefined frequency ranges. The drive accelerates and decelerates the motor through the prohibited frequency ranges. Setting 0.0 disables this function. Parameters must be set so that d3-01 ≥ d3-02 ≥ d3-03.	Default: <1> <2> Min.: 0.0 <2> Max.: 400.0 <2>	211
d3-04 (297)	Jump Frequency Width	All Modes Sets the dead-band width around each selected prohibited frequency reference point.	Default: <1> <3> Min.: 0.0 <3> Max.: 20.0 <3>	211

<1> Default setting is determined by parameter A1-02, Control Mode Setting.

<2> Default setting is 0.0% and setting range is 0.0 to 100.0% in AOLV/PM or CLV/PM.

<3> Default setting is 1.0% and setting range is 0.0 to 40.0% in AOLV/PM and CLV/PM.

◆ d4: Frequency Reference Hold and Up/Down 2 Function

No. (Addr. Hex)	Name	Description	Values	Page
d4-01 (298)	Frequency Reference Hold Function Selection	All Modes 0: Disabled. Drive starts from zero when the power is switched on. 1: Enabled. At power up, the drive starts the motor at the Hold frequency that was saved.	Default: 0 Range: 0, 1	212
d4-03 (2AA) 	Frequency Reference Bias Step (Up/Down 2)	All Modes Sets the bias added to the frequency reference when the Up 2 and Down 2 digital inputs are enabled (H1-□□ = 75, 76).	Default: 0.00 Hz Min.: 0.00 Max.: 99.99	214
d4-04 (2AB) 	Frequency Reference Bias Accel/Decel (Up/Down 2)	All Modes 0: Use selected accel/decel time. 1: Use accel/decel time 4 (C1-07 and C1-08).	Default: 0 Range: 0, 1	215
d4-05 (2AC) 	Frequency Reference Bias Operation Mode Selection (Up/Down 2)	All Modes 0: Bias value is held if no input Up 2 or Down 2 is active. 1: When the Up 2 reference and Down 2 reference are both on or both off, the applied bias becomes 0. The specified accel/decel times are used for acceleration or deceleration.	Default: 0 Range: 0, 1	215
d4-06 (2AD)	Frequency Reference Bias (Up/Down 2)	All Modes The Up/Down 2 bias value is saved in d4-06 when the frequency reference is not input by the digital operator. Set as a percentage of the maximum output frequency.	Default: 0.0% Min.: -99.9 Max.: 100.0	215
d4-07 (2AE) 	Analog Frequency Reference Fluctuation Limit (Up/Down 2)	All Modes Limits how much the frequency reference is allowed to change while an input terminal set for Up 2 or Down 2 is enabled. If the frequency reference changes for more than the set value, then the bias value is held and the drive accelerates or decelerates to the frequency reference. Set as a percentage of the maximum output frequency.	Default: 1.0% Min.: 0.1 Max.: 100.0	216

B.6 d: References

No. (Addr. Hex)	Name	Description	Values	Page
d4-08 (2AF) 	Frequency Reference Bias Upper Limit (Up/Down 2)	All Modes Sets the upper limit for the bias and the value that can be saved in d4-06. Set as a percentage of the maximum output frequency.	Default: 100.0% Min.: 0.0 Max.: 100.0	216
d4-09 (2B0) 	Frequency Reference Bias Lower Limit (Up/Down 2)	All Modes Sets the lower limit for the bias and the value that can be saved in d4-06. Set as a percentage of the maximum output frequency.	Default: 0.0% Min.: -99.9 Max.: 0.0	216
d4-10 (2B6)	Up/Down Frequency Reference Limit Selection	All Modes 0: The lower limit is determined by d2-02 or an analog input. 1: The lower limit is determined by d2-02.	Default: 0 Range: 0, 1	216

◆ d5: Torque Control

No. (Addr. Hex)	Name	Description	Values	Page
d5-01 (29A)	Torque Control Selection	<input type="radio"/> V/f <input type="radio"/> V/f w PG <input type="radio"/> OLV <input checked="" type="radio"/> CLV <input type="radio"/> OLV/PM <input type="radio"/> AOLV/PM <input checked="" type="radio"/> CLV/PM 0: Speed Control 1: Torque Control Set to 0 when using a digital input to switch between Speed and Torque Control (H1-□□ = 71).	Default: 0 Range: 0, 1	220
d5-02 (29B)	Torque Reference Delay Time	<input type="radio"/> V/f <input type="radio"/> V/f w PG <input type="radio"/> OLV <input checked="" type="radio"/> CLV <input type="radio"/> OLV/PM <input type="radio"/> AOLV/PM <input checked="" type="radio"/> CLV/PM Sets a delay time for the torque reference signal. Used to suppress effects by noisy or fluctuating torque reference signals.	Default: 0 ms Min.: 0 Max.: 1000	220
d5-03 (29C)	Speed Limit Selection	<input type="radio"/> V/f <input type="radio"/> V/f w PG <input type="radio"/> OLV <input checked="" type="radio"/> CLV <input type="radio"/> OLV/PM <input type="radio"/> AOLV/PM <input checked="" type="radio"/> CLV/PM 1: Limit set by the frequency reference in b1-01. 2: Limit set by d5-04.	Default: 1 Range: 1, 2	220
d5-04 (29D)	Speed Limit	<input type="radio"/> V/f <input type="radio"/> V/f w PG <input type="radio"/> OLV <input checked="" type="radio"/> CLV <input type="radio"/> OLV/PM <input type="radio"/> AOLV/PM <input checked="" type="radio"/> CLV/PM Sets the speed limit during Torque Control as a percentage of the maximum output frequency. Enabled when d5-03 = 2. A negative setting sets a limit in the opposite direction of the Run command.	Default: 0% Min.: -120 Max.: 120	221
d5-05 (29E)	Speed Limit Bias	<input type="radio"/> V/f <input type="radio"/> V/f w PG <input type="radio"/> OLV <input checked="" type="radio"/> CLV <input type="radio"/> OLV/PM <input type="radio"/> AOLV/PM <input checked="" type="radio"/> CLV/PM Sets the speed limit bias as a percentage of the maximum output frequency. The bias is applied to the specified speed limit and can adjust the margin for the speed limit.	Default: 10% Min.: 0 Max.: 120	221
d5-06 (29F)	Speed/Torque Control Switchover Time	<input type="radio"/> V/f <input type="radio"/> V/f w PG <input type="radio"/> OLV <input checked="" type="radio"/> CLV <input type="radio"/> OLV/PM <input type="radio"/> AOLV/PM <input checked="" type="radio"/> CLV/PM Sets the delay time for switching between Speed and Torque Control using an input terminal (H1-□□ = 71). Reference values are held during this switch delay time.	Default: 0 ms Min.: 0 Max.: 1000	221
d5-08 (2B5)	Unidirectional Speed Limit Bias	<input type="radio"/> V/f <input type="radio"/> V/f w PG <input type="radio"/> OLV <input checked="" type="radio"/> CLV <input type="radio"/> OLV/PM <input type="radio"/> AOLV/PM <input checked="" type="radio"/> CLV/PM 0: Disabled 1: Enabled	Default: 1 Range: 0, 1	221

◆ d6: Field Weakening and Field Forcing

No. (Addr. Hex.)	Name	Description	Values	Page
d6-01 (2A0)	Field Weakening Level	<p>V/f V/f w PG OLV CLV OLV/PM AOLV/PM CLV/PM</p> <p>Sets the drive output voltage for the Field Weakening function as a percentage of the maximum output voltage. Enabled when a multi-function input is set for Field Weakening (H1-□□ = 63).</p>	Default: 80% Min.: 0 Max.: 100	221
d6-02 (2A1)	Field Weakening Frequency Limit	<p>V/f V/f w PG OLV CLV OLV/PM AOLV/PM CLV/PM</p> <p>Sets the lower limit of the frequency range where Field Weakening control is valid. The Field Weakening command is valid only at frequencies above this setting and only when the output frequency matches the frequency reference (speed agree).</p>	Default: 0.0 Hz Min.: 0.0 Max.: 400.0	221
d6-03 (2A2)	Field Forcing Selection	<p>V/f V/f w PG OLV CLV OLV/PM AOLV/PM CLV/PM</p> <p>0: Disabled 1: Enabled</p>	Default: 0 Range: 0, 1	222
d6-06 (2A5)	Field Forcing Limit	<p>V/f V/f w PG OLV CLV OLV/PM AOLV/PM CLV/PM</p> <p>Sets the upper limit of the excitation current command during magnetic field forcing. A setting of 100% is equal to motor no-load current. Disabled only during DC Injection Braking.</p>	Default: 400% Min.: 100 Max.: 400	222

◆ d7: Offset Frequency

No. (Addr. Hex.)	Name	Description	Setting	Page
d7-01 (2B2) RUN	Offset Frequency 1	<p>All Modes</p> <p>Added to the frequency reference when the digital input “Frequency offset 1” (H1-□□ = 44) is switched on. A setting of 100% is equal to the drive maximum output current.</p>	Default: 0.0% Min.: -100.0 Max.: 100.0	222
d7-02 (2B3) RUN	Offset Frequency 2	<p>All Modes</p> <p>Added to the frequency reference when the digital input “Frequency offset 2” (H1-□□ = 45) is switched on. A setting of 100% is equal to the drive maximum output current.</p>	Default: 0.0% Min.: -100.0 Max.: 100.0	222
d7-03 (2B4) RUN	Offset Frequency 3	<p>All Modes</p> <p>Added to the frequency reference when the digital input “Frequency offset 3” (H1-□□ = 46) is switched on. A setting of 100% is equal to the drive maximum output current.</p>	Default: 0.0% Min.: -100.0 Max.: 100.0	222

B.7 E: Motor Parameters

◆ E1: V/f Pattern for Motor 1

No. (Addr. Hex)	Name	Description	Values	Page
E1-01 (300)	Input Voltage Setting	<p>All Modes</p> <p>This parameter must be set to the power supply voltage.</p> <p>WARNING! Electrical Shock Hazard. Drive input voltage (not motor voltage) must be set in E1-01 for the protective features of the drive to function properly. Failure to do so may result in equipment damage and/or death or personal injury.</p>	Default: 230 V <1> Min.: 155 Max.: 255 <1>	223
E1-03 (302)	V/f Pattern Selection	<p> <input checked="" type="radio"/> V/f <input type="radio"/> V/f w PG <input checked="" type="radio"/> OLV <input type="radio"/> CLV <input type="radio"/> OLV/PM <input type="radio"/> AOLV/PM <input type="radio"/> CLV/PM </p> <p> 0: 50 Hz, Constant torque 1 1: 60 Hz, Constant torque 2 2: 60 Hz, Constant torque 3 (50 Hz base) 3: 72 Hz, Constant torque 4 (60 Hz base) 4: 50 Hz, Variable torque 1 5: 50 Hz, Variable torque 2 6: 60 Hz, Variable torque 3 7: 60 Hz, Variable torque 4 8: 50 Hz, High starting torque 1 9: 50 Hz, High starting torque 2 A: 60 Hz, High starting torque 3 B: 60 Hz, High starting torque 4 C: 90 Hz (60 Hz base) D: 120 Hz (60 Hz base) E: 180 Hz (60 Hz base) F: Custom V/f, E1-04 through E1-13 settings define the V/f pattern </p>	Default: F <2> Range: 0 to 9; A to F <3>	223
E1-04 (303)	Maximum Output Frequency	<p>All Modes</p> <p>These parameters are only applicable when E1-03 is set to F. To set linear V/f characteristics, set the same values for E1-07 and E1-09. In this case, the setting for E1-08 will be disregarded. Ensure that the four frequencies are set according to these rules: $E1-09 \leq E1-07 < E1-06 \leq E1-11 \leq E1-04$</p> <p style="text-align: center;">Output Voltage (V)</p> <p style="text-align: center;">Frequency (Hz)</p> <p>Note: Some parameters may not be available depending on the control mode.</p> <ul style="list-style-type: none"> E1-07, E1-08, and E1-10 are available only in the following control modes: V/f Control, V/f with PG, Open Loop Vector. E1-11, E1-12, and E1-13 are available only in the following control modes: V/f Control, V/f with PG, Open Loop Vector, Closed Loop Vector. 	Default: <4> <5> Min.: 40.0 Max.: 400.0 <6>	226
E1-05 (304)	Maximum Voltage		Default: <4> <5> Min.: 0.0 V Max.: 255.0 V <1>	226
E1-06 (305)	Base Frequency		Default: <4> <5> Min.: 0.0 Max.: E1-04 <6>	226
E1-07 (306)	Middle Output Frequency		Default: <4> Min.: 0.0 Max.: E1-04	226
E1-08 (307)	Middle Output Frequency Voltage		Default: <4> Min.: 0.0 V Max.: 255.0 V <1>	226
E1-09 (308)	Minimum Output Frequency		Default: <4> <5> Min.: 0.0 Max.: E1-04 <6> <7>	226
E1-10 (309)	Minimum Output Frequency Voltage		Default: <4> Min.: 0.0 V Max.: 255.0 V <1>	226
E1-11 (30A) <9>	Middle Output Frequency 2		Default: 0.0 Hz Min.: 0.0 Max.: E1-04 <7>	226
E1-12 (30B) <9>	Middle Output Frequency Voltage 2		Default: 0.0 V Min.: 0.0 Max.: 255.0 V <1>	226
E1-13 (30C)	Base Voltage		Default: 0.0 V <8> Min.: 0.0 Max.: 255.0 V <1>	226

- <1> Values shown are specific to 200 V class drives. Double the value for 400 V class drives. Multiply the value by 2.875 for 600 V class drives.
- <2> Parameter setting value is not reset to the default value when the drive is initialized.
- <3> The setting value is F in OLV modes.
- <4> Default setting is dependent on parameters A1-02, Control Model Selection, C6-01, Drive Duty Selection, and o2-04, Drive Model Selection.
- <5> Default setting is dependent on parameter E5-01, Motor Code Selection.
- <6> In OLV/PM, setting range varies according to the motor code entered to E5-01. The setting range is 0.0 to 400.0 Hz when E5-01 is set to FFFF.
- <7> The setting range is 0.0 to 66.0 in AOLV/PM.
- <8> When Auto-Tuning is performed, E1-13 and E1-05 will be set to the same value.
- <9> Parameter ignored when E1-11 (Motor 1 Mid Output Frequency 2) and E1-12 (Motor 1 Mid Output Frequency Voltage 2) are set to 0.0.

◆ E2: Motor 1 Parameters

No. (Addr. Hex)	Name	Description	Values	Page
E2-01 (30E)	Motor Rated Current	<p>V/f V/f w PG OLV CLV</p> <p><input type="checkbox"/> OLV/PM <input type="checkbox"/> AOLV/PM <input type="checkbox"/> CLV/PM</p> <p>Sets the motor nameplate full load current in amps. Automatically set during Auto-Tuning.</p>	Default: </> Min.: 10% of drive rated current Max.: 200% of drive rated current <2>	227
E2-02 (30F)	Motor Rated Slip	<p>V/f V/f w PG OLV CLV</p> <p><input type="checkbox"/> OLV/PM <input type="checkbox"/> AOLV/PM <input type="checkbox"/> CLV/PM</p> <p>Sets the motor rated slip. Automatically set during Auto-Tuning.</p>	Default: </> Min.: 0.00 Hz Max.: 20.00 Hz	227
E2-03 (310)	Motor No-Load Current	<p>V/f V/f w PG OLV CLV</p> <p><input type="checkbox"/> OLV/PM <input type="checkbox"/> AOLV/PM <input type="checkbox"/> CLV/PM</p> <p>Sets the no-load current for the motor. Automatically set during Auto-Tuning.</p>	Default: </> Min.: 0 A Max.: E2-01 <2>	228
E2-04 (311)	Number of Motor Poles	<p>V/f V/f w PG OLV CLV</p> <p><input type="checkbox"/> OLV/PM <input type="checkbox"/> AOLV/PM <input type="checkbox"/> CLV/PM</p> <p>Sets the number of motor poles. Automatically set during Auto-Tuning.</p>	Default: 4 Min.: 2 Max.: 48	228
E2-05 (312)	Motor Line-to-Line Resistance	<p>V/f V/f w PG OLV CLV</p> <p><input type="checkbox"/> OLV/PM <input type="checkbox"/> AOLV/PM <input type="checkbox"/> CLV/PM</p> <p>Sets the phase-to-phase motor resistance. Automatically set during Auto-Tuning.</p> <p>Note: The units are expressed in mΩ in models 4A0930 and 4A1200.</p>	Default: </> Min.: 0.000 Ω Max.: 65.000 Ω	228
E2-06 (313)	Motor Leakage Inductance	<p>V/f V/f w PG OLV CLV</p> <p><input type="checkbox"/> OLV/PM <input type="checkbox"/> AOLV/PM <input type="checkbox"/> CLV/PM</p> <p>Sets the voltage drop due to motor leakage inductance as a percentage of motor rated voltage. Automatically set during Auto-Tuning.</p>	Default: </> Min.: 0.0% Max.: 40.0%	228
E2-07 (314)	Motor Iron-Core Saturation Coefficient 1	<p><input type="checkbox"/> V/f <input type="checkbox"/> V/f w PG OLV CLV</p> <p><input type="checkbox"/> OLV/PM <input type="checkbox"/> AOLV/PM <input type="checkbox"/> CLV/PM</p> <p>Sets the motor iron saturation coefficient at 50% of magnetic flux. Automatically set during Auto-Tuning.</p>	Default: 0.50 Min.: E2-07 Max.: 0.50	228
E2-08 (315)	Motor Iron-Core Saturation Coefficient 2	<p><input type="checkbox"/> V/f <input type="checkbox"/> V/f w PG OLV CLV</p> <p><input type="checkbox"/> OLV/PM <input type="checkbox"/> AOLV/PM <input type="checkbox"/> CLV/PM</p> <p>Sets the motor iron saturation coefficient at 75% of magnetic flux. Automatically set during Auto-Tuning.</p>	Default: 0.75 Min.: E2-07 Max.: 0.75	228
E2-09 (316)	Motor Mechanical Loss	<p><input type="checkbox"/> V/f <input type="checkbox"/> V/f w PG OLV CLV</p> <p><input type="checkbox"/> OLV/PM <input type="checkbox"/> AOLV/PM <input type="checkbox"/> CLV/PM</p> <p>Sets the motor mechanical loss as a percentage of motor rated power (kW).</p>	Default: 0.0% Min.: 0.0 Max.: 10.0	229
E2-10 (317)	Motor Iron Loss for Torque Compensation	<p>V/f V/f w PG <input type="checkbox"/> OLV <input type="checkbox"/> CLV</p> <p><input type="checkbox"/> OLV/PM <input type="checkbox"/> AOLV/PM <input type="checkbox"/> CLV/PM</p> <p>Sets the motor iron loss.</p>	Default: </> Min.: 0 W Max.: 65535 W	229
E2-11 (318)	Motor Rated Power	<p>V/f V/f w PG OLV CLV</p> <p><input type="checkbox"/> OLV/PM <input type="checkbox"/> AOLV/PM <input type="checkbox"/> CLV/PM</p> <p>Sets the motor rated power in kilowatts (1 HP = 0.746 kW). Automatically set during Auto-Tuning.</p>	Default: </> Min.: 0.00 kW Max.: 650.00 kW	229

B.7 E: Motor Parameters

- <1> Default setting is dependent on parameters C6-01, Drive Duty Selection, and o2-04, Drive Model Selection.
- <2> The number of decimal places in the parameter value depends on the drive model and the ND/HD selection in parameter C6-01. This value has two decimal places (0.01 A) if the drive is set for a maximum applicable motor capacity up to and including 11 kW, and one decimal place (0.1 A) if the maximum applicable motor capacity is higher than 11 kW.

◆ E3: V/f Pattern for Motor 2

These parameters are hidden when a PM motor control mode has been selected for motor 1 (A1-02 = 5, 6, 7).

No. (Addr. Hex)	Name	Description	Values	Page
E3-01 (319)	Motor 2 Control Mode Selection	<div style="display: flex; justify-content: space-around; align-items: center;"> <div style="border: 1px solid black; padding: 2px;">V/f</div> <div style="border: 1px solid black; padding: 2px;">V/f w PG</div> <div style="border: 1px solid black; padding: 2px;">OLV</div> <div style="border: 1px solid black; padding: 2px;">CLV</div> </div> <div style="display: flex; justify-content: space-around; align-items: center; margin-top: 5px;"> <div style="border: 1px solid black; padding: 2px;">OLV/PM</div> <div style="border: 1px solid black; padding: 2px;">AOLV/PM</div> <div style="border: 1px solid black; padding: 2px;">CLV/PM</div> </div> 0: V/f Control 1: V/f Control with PG 2: Open Loop Vector Control 3: Closed Loop Vector Control	Default: 0 Range: 0 to 3	230
E3-04 (31A)	Motor 2 Maximum Output Frequency	<div style="display: flex; justify-content: space-around; align-items: center;"> <div style="border: 1px solid black; padding: 2px;">V/f</div> <div style="border: 1px solid black; padding: 2px;">V/f w PG</div> <div style="border: 1px solid black; padding: 2px;">OLV</div> <div style="border: 1px solid black; padding: 2px;">CLV</div> </div> <div style="display: flex; justify-content: space-around; align-items: center; margin-top: 5px;"> <div style="border: 1px solid black; padding: 2px;">OLV/PM</div> <div style="border: 1px solid black; padding: 2px;">AOLV/PM</div> <div style="border: 1px solid black; padding: 2px;">CLV/PM</div> </div> These parameters are only applicable when E1-03 is set to F. To set linear V/f characteristics, set the same values for E3-07 and E3-09. In this case, the setting for E3-08 will be disregarded. Ensure that the four frequencies are set according to these rules or an oPE10 fault will occur: $E3-09 \leq E3-07 < E3-06 \leq E3-11 \leq E3-04$	Default: <1> Min.: 40.0 Max.: 400.0	230
E3-05 (31B)	Motor 2 Maximum Voltage		Default: <1> Min.: 0.0 V Max.: 255.0 V <2>	230
E3-06 (31C)	Motor 2 Base Frequency	Output Voltage (V)	Default: <1> Min.: 0.0 Max.: E3-04	230
E3-07 (31D)	Motor 2 Mid Output Frequency		Default: <1> Min.: 0.0 Max.: E3-04	230
E3-08 (31E)	Motor 2 Mid Output Frequency Voltage		Default: <1> Min.: 0.0 V Max.: 255.0 V <2>	230
E3-09 (31F)	Motor 2 Minimum Output Frequency		Default: <1> Min.: 0.0 Max.: E3-04	230
E3-10 (320)	Motor 2 Minimum Output Frequency Voltage		Default: <1> Min.: 0.0 V Max.: 255.0 V <2>	230
E3-11 (345) <3>	Motor 2 Mid Output Frequency 2		Note: E3-07 and E3-08 are only available in the following control modes: V/f, V/f w/PG and OLV.	Default: 0.0 Min.: 0.0 Max.: E3-04
E3-12 (346) <3>	Motor 2 Mid Output Frequency Voltage 2		Default: 0.0 V Min.: 0.0 Max.: 255.0 <2>	230
E3-13 (347)	Motor 2 Base Voltage		Default: 0.0 V Min.: 0.0 Max.: 255.0 <2>	230

- <1> Default setting is dependent on E3-01, Motor 2 Control Mode Selection. The value shown here is for V/f Control (0).
- <2> Values shown are specific to 200 V class drives. Double the value for 400 V class drives. Multiply the value by 2.875 for 600 V class drives.
- <3> Ignored when E3-11, Motor 2 Mid Output Frequency 2, and E3-12, Motor 2 Mid Output Frequency Voltage 2, are set to 0.

◆ E4: Motor 2 Parameters

These parameters are hidden when a PM motor control mode has been selected for motor 1 (A1-02 = 5, 6, 7).

No. (Addr. Hex)	Name	Description	Values	Page
E4-01 (321)	Motor 2 Rated Current	<p><input checked="" type="radio"/> V/f <input checked="" type="radio"/> V/f w PG <input checked="" type="radio"/> OLV <input checked="" type="radio"/> CLV</p> <p><input type="radio"/> OLV/PM <input type="radio"/> AOLV/PM <input type="radio"/> CLV/PM</p> <p>Sets the full load current for motor 2. Automatically set during Auto-Tuning.</p>	Default: </> Min.: 10% of drive rated current Max.: 200% of drive rated current <2>	231
E4-02 (322)	Motor 2 Rated Slip	<p><input checked="" type="radio"/> V/f <input checked="" type="radio"/> V/f w PG <input checked="" type="radio"/> OLV <input checked="" type="radio"/> CLV</p> <p><input type="radio"/> OLV/PM <input type="radio"/> AOLV/PM <input type="radio"/> CLV/PM</p> <p>Sets the rated slip for motor 2. Automatically set during Auto-Tuning.</p>	Default: </> Min.: 0.00 Hz Max.: 20.00 Hz <2>	231
E4-03 (323)	Motor 2 Rated No-Load Current	<p><input checked="" type="radio"/> V/f <input checked="" type="radio"/> V/f w PG <input checked="" type="radio"/> OLV <input checked="" type="radio"/> CLV</p> <p><input type="radio"/> OLV/PM <input type="radio"/> AOLV/PM <input type="radio"/> CLV/PM</p> <p>Sets the no-load current for motor 2. Automatically set during Auto-Tuning.</p>	Default: </> Min.: 0 A Max.: E4-01 <2>	231
E4-04 (324)	Motor 2 Motor Poles	<p><input checked="" type="radio"/> V/f <input checked="" type="radio"/> V/f w PG <input checked="" type="radio"/> OLV <input checked="" type="radio"/> CLV</p> <p><input type="radio"/> OLV/PM <input type="radio"/> AOLV/PM <input type="radio"/> CLV/PM</p> <p>Sets the number of poles of motor 2. Automatically set during Auto-Tuning.</p>	Default: 4 Min.: 2 Max.: 48	232
E4-05 (325)	Motor 2 Line-to-Line Resistance	<p><input checked="" type="radio"/> V/f <input checked="" type="radio"/> V/f w PG <input checked="" type="radio"/> OLV <input checked="" type="radio"/> CLV</p> <p><input type="radio"/> OLV/PM <input type="radio"/> AOLV/PM <input type="radio"/> CLV/PM</p> <p>Sets the phase-to-phase resistance for motor 2. Automatically set during Auto-Tuning.</p> <p>Note: The units are expressed in mΩ in models 4A0930 and 4A1200.</p>	Default: </> Min.: 0.000 Ω Max.: 65.000 Ω	232
E4-06 (326)	Motor 2 Leakage Inductance	<p><input checked="" type="radio"/> V/f <input checked="" type="radio"/> V/f w PG <input checked="" type="radio"/> OLV <input checked="" type="radio"/> CLV</p> <p><input type="radio"/> OLV/PM <input type="radio"/> AOLV/PM <input type="radio"/> CLV/PM</p> <p>Sets the voltage drop for motor 2 due to motor leakage inductance as a percentage of rated voltage. Automatically set during Auto-Tuning.</p>	Default: </> Min.: 0.0% Max.: 40.0%	232
E4-07 (343)	Motor 2 Motor Iron-Core Saturation Coefficient 1	<p><input type="radio"/> V/f <input type="radio"/> V/f w PG <input checked="" type="radio"/> OLV <input checked="" type="radio"/> CLV</p> <p><input type="radio"/> OLV/PM <input type="radio"/> AOLV/PM <input type="radio"/> CLV/PM</p> <p>Set to the motor iron saturation coefficient at 50% of magnetic flux for motor 2. Automatically set during Auto-Tuning.</p>	Default: 0.50 Min.: 0.00 Max.: 0.50	232
E4-08 (344)	Motor 2 Motor Iron-Core Saturation Coefficient 2	<p><input type="radio"/> V/f <input type="radio"/> V/f w PG <input checked="" type="radio"/> OLV <input checked="" type="radio"/> CLV</p> <p><input type="radio"/> OLV/PM <input type="radio"/> AOLV/PM <input type="radio"/> CLV/PM</p> <p>Set to the motor iron saturation coefficient at 75% of magnetic flux for motor 2. This value is automatically set during Auto-Tuning.</p>	Default: 0.75 Min.: E4-07 Max.: 0.75	232
E4-09 (33F)	Motor 2 Mechanical Loss	<p><input type="radio"/> V/f <input type="radio"/> V/f w PG <input checked="" type="radio"/> OLV <input checked="" type="radio"/> CLV</p> <p><input type="radio"/> OLV/PM <input type="radio"/> AOLV/PM <input type="radio"/> CLV/PM</p> <p>Sets the motor mechanical loss for motor 2 as a percentage of motor rated power (kW).</p>	Default: 0.0% Min.: 0.0 Max.: 10.0	232
E4-10 (340)	Motor 2 Iron Loss	<p><input checked="" type="radio"/> V/f <input checked="" type="radio"/> V/f w PG <input type="radio"/> OLV <input type="radio"/> CLV</p> <p><input type="radio"/> OLV/PM <input type="radio"/> AOLV/PM <input type="radio"/> CLV/PM</p> <p>Sets the motor iron loss.</p>	Default: </> Min.: 0 W Max.: 65535 W	232
E4-11 (327)	Motor 2 Rated Power	<p><input checked="" type="radio"/> V/f <input checked="" type="radio"/> V/f w PG <input checked="" type="radio"/> OLV <input checked="" type="radio"/> CLV</p> <p><input type="radio"/> OLV/PM <input type="radio"/> AOLV/PM <input type="radio"/> CLV/PM</p> <p>Sets the motor rated capacity in kW. Automatically set during Auto-Tuning.</p>	Default: </> Min.: 0.00 kW Max.: 650.00 kW	233

<1> Default setting is dependent on parameters C6-01, Drive Duty Selection, and o2-04, Drive Model Selection.

<2> The number of decimal places in the parameter value depends on the drive model and the ND/HD selection in parameter C6-01. This value has two decimal places (0.01 A) if the drive is set for a maximum applicable motor capacity up to and including 11 kW, and one decimal place (0.1 A) if the maximum applicable motor capacity is higher than 11 kW.

◆ E5: PM Motor Settings

No. (Addr. Hex)	Name	Description	Values	Page
E5-01 (329) <2>	Motor Code Selection	<div style="display: flex; justify-content: space-between; margin-bottom: 5px;"> V/f V/f w PG OLV CLV </div> <div style="display: flex; justify-content: space-between;"> OLV/PM AOLV/PM CLV/PM </div> <p>Enter the Yaskawa motor code for the PM motor being used. Various motor parameters are automatically set based on the value of this parameter. Settings that were changed manually will be overwritten by the defaults of the selected motor code.</p> <p>Note: Set to FFFF when using a non-Yaskawa PM motor.</p>	Default: <3> <6> Min.: 0000 Max.: FFFF <4>	233
E5-02 (32A) <2>	Motor Rated Power	<div style="display: flex; justify-content: space-between; margin-bottom: 5px;"> V/f V/f w PG OLV CLV </div> <div style="display: flex; justify-content: space-between;"> OLV/PM AOLV/PM CLV/PM </div> <p>Sets the rated capacity of the motor.</p>	Default: <3> Min.: 0.10 kW Max.: 650.00 kW	234
E5-03 (32B) <2>	Motor Rated Current	<div style="display: flex; justify-content: space-between; margin-bottom: 5px;"> V/f V/f w PG OLV CLV </div> <div style="display: flex; justify-content: space-between;"> OLV/PM AOLV/PM CLV/PM </div> <p>Sets the motor rated current.</p>	Default: <3> Min.: 10% of drive rated current Max.: 200% of drive rated current <4>	234
E5-04 (32C) <2>	Number of Motor Poles	<div style="display: flex; justify-content: space-between; margin-bottom: 5px;"> V/f V/f w PG OLV CLV </div> <div style="display: flex; justify-content: space-between;"> OLV/PM AOLV/PM CLV/PM </div> <p>Sets the number of motor poles.</p>	Default: <3> Min.: 2 Max.: 48	234
E5-05 (32D) <2>	Motor Stator Resistance	<div style="display: flex; justify-content: space-between; margin-bottom: 5px;"> V/f V/f w PG OLV CLV </div> <div style="display: flex; justify-content: space-between;"> OLV/PM AOLV/PM CLV/PM </div> <p>Set the resistance for each motor phase.</p>	Default: <3> Min.: 0.000 Ω Max.: 65.000 Ω	234
E5-06 (32E) <2>	Motor d-Axis Inductance	<div style="display: flex; justify-content: space-between; margin-bottom: 5px;"> V/f V/f w PG OLV CLV </div> <div style="display: flex; justify-content: space-between;"> OLV/PM AOLV/PM CLV/PM </div> <p>Sets the d-Axis inductance for the PM motor.</p>	Default: <3> Min.: 0.00 mH Max.: 300.00 mH	234
E5-07 (32F) <2>	Motor q-Axis Inductance	<div style="display: flex; justify-content: space-between; margin-bottom: 5px;"> V/f V/f w PG OLV CLV </div> <div style="display: flex; justify-content: space-between;"> OLV/PM AOLV/PM CLV/PM </div> <p>Sets the q-Axis inductance for the PM motor.</p>	Default: <3> Min.: 0.00 mH Max.: 600.00 mH	234
E5-09 (331) <2>	Motor Induction Voltage Constant 1	<div style="display: flex; justify-content: space-between; margin-bottom: 5px;"> V/f V/f w PG OLV CLV </div> <div style="display: flex; justify-content: space-between;"> OLV/PM AOLV/PM CLV/PM </div> <p>Sets the induced phase peak voltage in units of 0.1 mV/(rad/s) [electrical angle]. Set this parameter when using a Yaskawa SSR1-Series PM motor with derated torque, or a Yaskawa SST4-Series motor with constant torque. Set E5-24 to 0 when setting this parameter.</p>	Default: <3> Min.: 0.0 mV/(rad/s) Max.: 2000.0 mV/(rad/s)	234
E5-11 (333)	Encoder Z Pulse Offset	<div style="display: flex; justify-content: space-between; margin-bottom: 5px;"> V/f V/f w PG OLV CLV </div> <div style="display: flex; justify-content: space-between;"> OLV/PM AOLV/PM CLV/PM </div> <p>Sets the offset between the rotor magnetic axis and the Z Pulse of an incremental encoder during Z Pulse offset tuning.</p>	Default: 0.0 deg Min.: -180 Max.: 180	235
E5-24 (353) <2>	Motor Induction Voltage Constant 2	<div style="display: flex; justify-content: space-between; margin-bottom: 5px;"> V/f V/f w PG OLV CLV </div> <div style="display: flex; justify-content: space-between;"> OLV/PM AOLV/PM CLV/PM </div> <p>Sets the induced phase-to-phase rms voltage in units of 0.1 mV/(r/min) [mechanical angle]. Set this parameter when using a Yaskawa SMRA-Series SPM motor.</p>	Default: <3> Min.: 0.0 mV/(r/min) Max.: 6500.0 mV/(r/min)	235
E5-25 (35E)	Polarity Switch for Initial Polarity Estimation	<div style="display: flex; justify-content: space-between; margin-bottom: 5px;"> V/f V/f w PG OLV CLV </div> <div style="display: flex; justify-content: space-between;"> OLV/PM AOLV/PM CLV/PM </div> <p>Switches polarity for initial polarity estimation.</p> <p>Note: This parameter is available in models 4A0930 and 4A1200.</p>	Default: 0 Range: 0, 1	235

- <1> Selections may vary depending on the motor code entered to E5-01.
- <2> Setting value is not reset to the default when drive is initialized.
- <3> Default setting is dependent on parameter E5-01, Motor Code Selection.
- <4> The number of decimal places in the parameter value depends on the drive model and the ND/HD selection in parameter C6-01. This value has two decimal places (0.01 A) if the drive is set for a maximum applicable motor capacity up to and including 11 kW, and one decimal place (0.1 A) if the maximum applicable motor capacity is higher than 11 kW.
- <5> Default setting is dependent on parameters A1-02, Control Method Selection, o2-04, Drive Model Selection, and C6-01, Drive Duty Selection.

<6> When using a Yaskawa SMRA Series SPM Motor, the default setting is 1800 r/min..

B.8 F: Options

F parameters program the drive for PG feedback from the motor and to function with option cards.

◆ F1: PG Speed Control Card (PG-X3/PG-B3)

Parameters F1-01, F1-05, F1-06, F1-12, F1-13, and F1-18 through F1-21 include “PG 1” in the parameter name and are used to set up a PG option card plugged into option port CN5-C of the drive.

Parameters F1-21 through F1-37 include “PG 2” in the parameter name and are used to set up a PG option card plugged into option port CN5-B of the drive.

Other parameters in the F1 group are used to set operation for PG options plugged into port CN5-C and CN5-B.

No. (Addr. Hex)	Name	Description	Values	Page
F1-01 (380)	PG 1 Pulses Per Revolution	<div style="display: flex; justify-content: space-between; align-items: center;"> V/f V/f w PG OLV CLV </div> <div style="display: flex; justify-content: space-between; align-items: center;"> OLV/PM AOLV/PM CLV/PM </div> <p>Sets the number of PG (pulse generator or encoder) pulses. Sets the number of pulses per motor revolution.</p> <p>Note: Setting range is 0 to 15000 ppr when A1-02 = 7 (CLV/PM control mode).</p>	Default: 1024 ppr Min.: 1 Max.: 60000	236
F1-02 (381)	Operation Selection at PG Open Circuit (PGo)	<div style="display: flex; justify-content: space-between; align-items: center;"> V/f V/f w PG OLV CLV </div> <div style="display: flex; justify-content: space-between; align-items: center;"> OLV/PM AOLV/PM CLV/PM </div> <p>0: Ramp to stop. Decelerate to stop using the deceleration time in C1-02. 1: Coast to stop. 2: Fast Stop. Decelerate to stop using the deceleration time in C1-09. 3: Alarm only. 4: No alarm display</p> <p>Note: Due to potential damage to the motor and machinery, only use the “Alarm only” and “No alarm display” settings under special circumstances.</p>	Default: 1 Range: 0 to 4	236
F1-03 (382)	Operation Selection at Overspeed (oS)	<div style="display: flex; justify-content: space-between; align-items: center;"> V/f V/f w PG OLV CLV </div> <div style="display: flex; justify-content: space-between; align-items: center;"> OLV/PM AOLV/PM CLV/PM </div> <p>0: Ramp to stop. Decelerate to stop using the deceleration time in C1-02. 1: Coast to stop. 2: Fast Stop. Decelerate to stop using the deceleration time in C1-09. 3: Alarm only.</p>	Default: 1 Range: 0 to 3	236
F1-04 (383)	Operation Selection at Deviation	<div style="display: flex; justify-content: space-between; align-items: center;"> V/f V/f w PG OLV CLV </div> <div style="display: flex; justify-content: space-between; align-items: center;"> OLV/PM AOLV/PM CLV/PM </div> <p>0: Ramp to stop. Decelerate to stop using the deceleration time in C1-02. 1: Coast to stop. 2: Fast Stop. Decelerate to stop using the deceleration time in C1-09. 3: Alarm only.</p>	Default: 3 Range: 0 to 3	237
F1-05 (384)	PG 1 Rotation Selection	<div style="display: flex; justify-content: space-between; align-items: center;"> V/f V/f w PG OLV CLV </div> <div style="display: flex; justify-content: space-between; align-items: center;"> OLV/PM AOLV/PM CLV/PM </div> <p>0: Pulse A leads 1: Pulse B leads</p>	Default: </> Range: 0, 1	237
F1-06 (385)	PG 1 Division Rate for PG Pulse Monitor	<div style="display: flex; justify-content: space-between; align-items: center;"> V/f V/f w PG OLV CLV </div> <div style="display: flex; justify-content: space-between; align-items: center;"> OLV/PM AOLV/PM CLV/PM </div> <p>Sets the division ratio for the pulse monitor used of the PG option card installed to port CN5-C. By setting “xyz”, the division ratio becomes = [(1 + x) / yz]. If only using the A pulse for one-track input, the input ratio will be 1:1 regardless of F1-06 setting.</p>	Default: 1 Min.: 1 Max.: 132	237
F1-08 (387)	Overspeed Detection Level	<div style="display: flex; justify-content: space-between; align-items: center;"> V/f V/f w PG OLV CLV </div> <div style="display: flex; justify-content: space-between; align-items: center;"> OLV/PM AOLV/PM CLV/PM </div> <p>Sets the overspeed detection level as a percentage of the maximum output frequency.</p>	Default: 115% Min.: 0 Max.: 120	236

No. (Addr. Hex)	Name	Description	Values	Page
F1-09 (388)	Overspeed Detection Delay Time	<input type="checkbox"/> V/f <input checked="" type="checkbox"/> V/f w PG <input type="checkbox"/> OLV <input checked="" type="checkbox"/> CLV <input type="checkbox"/> OLV/PM <input checked="" type="checkbox"/> AOLV/PM <input checked="" type="checkbox"/> CLV/PM Sets the time in seconds for an overspeed situation to trigger a fault (oS).	Default: </> Min.: 0.0 s Max.: 2.0 s	236
F1-10 (389)	Excessive Speed Deviation Detection Level	<input type="checkbox"/> V/f <input checked="" type="checkbox"/> V/f w PG <input type="checkbox"/> OLV <input checked="" type="checkbox"/> CLV <input type="checkbox"/> OLV/PM <input checked="" type="checkbox"/> AOLV/PM <input checked="" type="checkbox"/> CLV/PM Sets the speed deviation detection level as a percentage of the maximum output frequency.	Default: 10% Min.: 0 Max.: 50	237
F1-11 (38A)	Excessive Speed Deviation Detection Delay Time	<input type="checkbox"/> V/f <input checked="" type="checkbox"/> V/f w PG <input type="checkbox"/> OLV <input checked="" type="checkbox"/> CLV <input type="checkbox"/> OLV/PM <input checked="" type="checkbox"/> AOLV/PM <input checked="" type="checkbox"/> CLV/PM Sets the time in seconds for a speed deviation situation to trigger a fault (dEv).	Default: 0.5 s Min.: 0.0 Max.: 10.0	237
F1-12 (38B)	PG 1 Gear Teeth 1	<input type="checkbox"/> V/f <input checked="" type="checkbox"/> V/f w PG <input type="checkbox"/> OLV <input type="checkbox"/> CLV <input type="checkbox"/> OLV/PM <input type="checkbox"/> AOLV/PM <input type="checkbox"/> CLV/PM Sets the gear ratio between the motor shaft and the encoder (PG). A gear ratio of 1 will be used if F1-12 or F1-13 are set to 0.	Default: 0 Min.: 0 Max.: 1000	237
F1-13 (38C)	PG 1 Gear Teeth 2	<input type="checkbox"/> V/f <input checked="" type="checkbox"/> V/f w PG <input type="checkbox"/> OLV <input type="checkbox"/> CLV <input type="checkbox"/> OLV/PM <input type="checkbox"/> AOLV/PM <input type="checkbox"/> CLV/PM Sets the gear ratio between the motor shaft and the encoder (PG). A gear ratio of 1 will be used if F1-12 or F1-13 are set to 0.	Default: 0 Min.: 0 Max.: 1000	237
F1-14 (38D)	PG Open-Circuit Detection Time	<input type="checkbox"/> V/f <input checked="" type="checkbox"/> V/f w PG <input type="checkbox"/> OLV <input checked="" type="checkbox"/> CLV <input type="checkbox"/> OLV/PM <input type="checkbox"/> AOLV/PM <input checked="" type="checkbox"/> CLV/PM Sets the time required to trigger a PG Open fault (PGo).	Default: 2.0 s Min.: 0.0 Max.: 10.0	236
F1-18 (3AD)	dv3 Detection Selection	<input type="checkbox"/> V/f <input type="checkbox"/> V/f w PG <input type="checkbox"/> OLV <input type="checkbox"/> CLV <input type="checkbox"/> OLV/PM <input type="checkbox"/> AOLV/PM <input checked="" type="checkbox"/> CLV/PM 0: Disabled n: Number of dv3 occurrences that must be detected to trigger a dv3 fault.	Default: 10 Min.: 0 Max.: 10	238
F1-19 (3AE)	dv4 Detection Selection	<input type="checkbox"/> V/f <input type="checkbox"/> V/f w PG <input type="checkbox"/> OLV <input type="checkbox"/> CLV <input type="checkbox"/> OLV/PM <input type="checkbox"/> AOLV/PM <input checked="" type="checkbox"/> CLV/PM 0: Disabled n: Number of pulses that the A and B pulse are reversed that triggers dv4 detection.	Default: 128 Min.: 0 Max.: 5000	238
F1-20 (3B4)	PG Option Card Disconnect Detection 1	<input type="checkbox"/> V/f <input checked="" type="checkbox"/> V/f w PG <input type="checkbox"/> OLV <input checked="" type="checkbox"/> CLV <input type="checkbox"/> OLV/PM <input type="checkbox"/> AOLV/PM <input checked="" type="checkbox"/> CLV/PM 0: Disabled 1: Enabled	Default: 1 Range: 0, 1	238
F1-21 (3BC)	PG 1 Signal Selection	<input type="checkbox"/> V/f <input checked="" type="checkbox"/> V/f w PG <input type="checkbox"/> OLV <input type="checkbox"/> CLV <input type="checkbox"/> OLV/PM <input type="checkbox"/> AOLV/PM <input type="checkbox"/> CLV/PM 0: A pulse detection 1: AB pulse detection	Default: 0 Range: 0, 1	238
F1-30 (3AA)	PG Card Option Port for Motor 2 Selection	<input type="checkbox"/> V/f <input checked="" type="checkbox"/> V/f w PG <input type="checkbox"/> OLV <input checked="" type="checkbox"/> CLV <input type="checkbox"/> OLV/PM <input type="checkbox"/> AOLV/PM <input type="checkbox"/> CLV/PM Sets the port for the PG option card used by motor 2. 0: CN5-C 1: CN5-B	Default: 1 Range: 0, 1	239
F1-31 (3B0)	PG 2 Pulses Per Revolution	<input type="checkbox"/> V/f <input checked="" type="checkbox"/> V/f w PG <input type="checkbox"/> OLV <input checked="" type="checkbox"/> CLV <input type="checkbox"/> OLV/PM <input type="checkbox"/> AOLV/PM <input type="checkbox"/> CLV/PM Sets the number of pulses for a PG option card connected to port CN5-B.	Default: 1024 ppr Min.: 1 Max.: 60000	236
F1-32 (3B1)	PG 2 Rotation Selection	<input type="checkbox"/> V/f <input checked="" type="checkbox"/> V/f w PG <input type="checkbox"/> OLV <input checked="" type="checkbox"/> CLV <input type="checkbox"/> OLV/PM <input type="checkbox"/> AOLV/PM <input type="checkbox"/> CLV/PM 0: Pulse A leads 1: Pulse B leads	Default: 0 Range: 0, 1	237
F1-33 (3B2)	PG 2 Gear Teeth 1	<input type="checkbox"/> V/f <input checked="" type="checkbox"/> V/f w PG <input type="checkbox"/> OLV <input type="checkbox"/> CLV <input type="checkbox"/> OLV/PM <input type="checkbox"/> AOLV/PM <input type="checkbox"/> CLV/PM Sets the gear ratio between the motor shaft and the encoder (PG). A gear ratio of 1 will be used if F1-33 or F1-34 are set to 0.	Default: 0 Min.: 0 Max.: 1000	237

B.8 F: Options

No. (Addr. Hex)	Name	Description	Values	Page
F1-34 (3B3)	PG 2 Gear Teeth 2	<div style="display: flex; justify-content: space-between; align-items: center;"> V/f V/f w PG OLV CLV </div> <div style="display: flex; justify-content: space-between; align-items: center; margin-top: 5px;"> OLV/PM AOLV/PM CLV/PM </div> <p>Sets the gear ratio between the motor shaft and the encoder (PG). A gear ratio of 1 will be used if F1-33 or F1-34 are set to 0.</p>	Default: 0 Min.: 0 Max.: 1000	237
F1-35 (3BE)	PG 2 Division Rate for Pulse Monitor	<div style="display: flex; justify-content: space-between; align-items: center;"> V/f V/f w PG OLV CLV </div> <div style="display: flex; justify-content: space-between; align-items: center; margin-top: 5px;"> OLV/PM AOLV/PM CLV/PM </div> <p>Sets the division ratio for the pulse monitor used of the PG option card 2 installed to port CN5-B. By setting "xyz", the division ratio becomes = $[(1 + x) / yz]$.</p>	Default: 1 Min.: 1 Max.: 132	237
F1-36 (3B5)	PG Option Card Disconnect Detection 2	<div style="display: flex; justify-content: space-between; align-items: center;"> V/f V/f w PG OLV CLV </div> <div style="display: flex; justify-content: space-between; align-items: center; margin-top: 5px;"> OLV/PM AOLV/PM CLV/PM </div> <p>0: Disabled 1: Enabled</p>	Default: 1 Range: 0, 1	238
F1-37 (3BD)	PG 2 Signal Selection	<div style="display: flex; justify-content: space-between; align-items: center;"> V/f V/f w PG OLV CLV </div> <div style="display: flex; justify-content: space-between; align-items: center; margin-top: 5px;"> OLV/PM AOLV/PM CLV/PM </div> <p>0: A pulse detection 1: AB pulse detection</p>	Default: 0 Range: 0, 1	238

<1> Default setting is determined by parameter A1-02, Control Method Selection.

◆ F2: Analog Input Card (AI-A3)

No. (Addr. Hex)	Name	Description	Values	Page
F2-01 (38F)	Analog Input Option Card Operation Selection	<p>All Modes</p> <p>0: Option card input terminals V1, V2, and V3 replace drive input terminals A1, A2, and A3. 1: Input signals to terminals V1, V2, and V3 are added together to create the frequency reference.</p>	Default: 0 Range: 0, 1	239
F2-02 (368) 	Analog Input Option Card Gain	<p>All Modes</p> <p>Sets the gain for the input signal to the analog card.</p>	Default: 100.0% Min.: -999.9 Max.: 999.9	239
F2-03 (369) 	Analog Input Option Card Bias	<p>All Modes</p> <p>Sets the bias for the input signal to the analog card.</p>	Default: 0.0% Min.: -999.9 Max.: 999.9	239

◆ F3: Digital Input Card (DI-A3)

No. (Addr. Hex)	Name	Description	Values	Page
F3-01 (390)	Digital Input Option Card Input Selection	<p>All Modes</p> <p>0: BCD, 1% units 1: BCD, 0.1% units 2: BCD, 0.01% units 3: BCD, 1 Hz units 4: BCD, 0.1 Hz units 5: BCD, 0.01 Hz units 6: BCD customized setting (5-digit), 0.02 Hz units 7: Binary input</p> <p>The unit and the setting range are determined by F3-03. F3-03 = 0: 255/100% (-255 to +255) F3-03 = 1: 40961/100% (-4095 to +4095) F3-03 = 2: 30000/100% (-33000 to +33000)</p> <p>When the digital operator units are set to be displayed in Hz or user-set units (o1-03 = 2 or 3), the units for F3-01 are determined by parameter o1-03.</p>	Default: 0 Range: 0 to 7	239
F3-03 (3B9)	Digital Input Option DI-A3 Data Length Selection	<p>All Modes</p> <p>0: 8 bit 1: 12 bit 2: 16 bit</p>	Default: 2 Range: 0 to 2	240

◆ F4: Analog Monitor Card (AO-A3)

No. (Addr. Hex)	Name	Description	Values	Page
F4-01 (391)	Terminal V1 Monitor Selection	All Modes Sets the monitor signal for output from terminal V1. Set this parameter to the last three digits of the desired U□-□□ monitor. Some U parameters are available only in certain control modes.	Default: 102 Range: 000 to 999	240
F4-02 (392) ↕ RUN	Terminal V1 Monitor Gain	All Modes Sets the gain for voltage output via terminal V1.	Default: 100.0% Min.: -999.9 Max.: 999.9	240
F4-03 (393)	Terminal V2 Monitor Selection	All Modes Sets the monitor signal for output from terminal V2. Set this parameter to the last three digits of the desired U□-□□ monitor. Some U parameters are available only in certain control modes.	Default: 103 Range: 000 to 999	240
F4-04 (394) ↕ RUN	Terminal V2 Monitor Gain	All Modes Sets the gain for voltage output via terminal V2.	Default: 50.0% Min.: -999.9 Max.: 999.9	240
F4-05 (395) ↕ RUN	Terminal V1 Monitor Bias	All Modes Sets the amount of bias added to the voltage output via terminal V1.	Default: 0.0% Min.: -999.9 Max.: 999.9	240
F4-06 (396) ↕ RUN	Terminal V2 Monitor Bias	All Modes Sets the amount of bias added to the voltage output via terminal V2.	Default: 0.0% Min.: -999.9 Max.: 999.9	240
F4-07 (397)	Terminal V1 Signal Level	All Modes 0: 0 to 10 V 1: -10 to 10 V	Default: 0 Range: 0, 1	241
F4-08 (398)	Terminal V2 Signal Level	All Modes 0: 0 to 10 V 1: -10 to 10 V	Default: 0 Range: 0, 1	241

◆ F5: Digital Output Card (DO-A3)

No. (Addr. Hex)	Name	Description	Values	Page
F5-01 (399)	Terminal P1-PC Output Selection	All Modes Sets the function for contact output terminals M1-M2, M3-M4, and photocoupler output terminals P1 through P6.	Default: 2 Range: 0 to 192	241
F5-02 (39A)	Terminal P2-PC Output Selection		Default: 4 Range: 0 to 192	241
F5-03 (39B)	Terminal P3-PC Output Selection		Default: 6 Range: 0 to 192	241
F5-04 (39C)	Terminal P4-PC Output Selection		Default: 37 Range: 0 to 192	241
F5-05 (39D)	Terminal P5-PC Output Selection		Default: F Range: 0 to 192	241
F5-06 (39E)	Terminal P6-PC Output Selection		Default: F Range: 0 to 192	241
F5-07 (39F)	Terminal M1-M2 Output Selection		Default: 0 Range: 0 to 192	241
F5-08 (3A0)	Terminal M3-M4 Output Selection		Default: 1 Range: 0 to 192	241
F5-09 (3A1)	DO-A3 Output Mode Selection	All Modes 0: Output terminals are each assigned separate output functions. 1: Binary code output. 2: Use output terminal functions selected by parameters F5-01 through F5-08.	Default: 0 Range: 0 to 2	241

◆ F6, F7: Communication Option Card

Parameters F6-01 through F6-03 and F6-06 through F6-08 are used for CC-Link, CANopen, DeviceNet, PROFIBUS-DP, and MECHATROLINK-II options. Other parameters in the F6 group are used for communication-protocol-specific settings. F7 parameters are used for EtherNet/IP, Modbus TCP/IP, and PROFINET options.

No. (Addr. Hex)	Name	Description	Values	Page
F6-01 (3A2)	Communications Error Operation Selection	All Modes 0: Ramp to stop. Decelerate to stop using the deceleration time in C1-02. 1: Coast to stop. 2: Fast Stop. Decelerate to stop using the deceleration time in C1-09. 3: Alarm only.	Default: 1 Range: 0 to 3	242
F6-02 (3A3)	External Fault from Comm. Option Detection Selection	All Modes 0: Always detected. 1: Detection during run only.	Default: 0 Range: 0, 1	242
F6-03 (3A4)	External Fault from Comm. Option Operation Selection	All Modes 0: Ramp to stop. Decelerate to stop using the deceleration time in C1-02. 1: Coast to stop. 2: Fast Stop. Decelerate to stop using the deceleration time in C1-09. 3: Alarm only.	Default: 1 Range: 0 to 3	242
F6-04 (3A5)	bUS Error Detection Time	All Modes Sets the delay time for error detection if a bus error occurs.	Default: 2.0 s Min.: 0.0 Max.: 5.0	243
F6-06 (3A7)	Torque Reference/Torque Limit Selection from Comm. Option	<input type="radio"/> V/f <input type="radio"/> V/f w PG <input type="radio"/> OLV <input checked="" type="radio"/> CLV <input type="radio"/> OLV/PM <input checked="" type="radio"/> AOLV/PM <input checked="" type="radio"/> CLV/PM 0: Disabled. Torque reference/limit from option board disabled. 1: Enabled. Torque reference/limit from option board enabled.	Default: 0 Range: 0, 1	242
F6-07 (3A8)	Multi-Step Speed Enable/Disable Selection when NefRef/ComRef is Selected	All Modes 0: Multi-step reference disabled (same as F7) 1: Multi-step reference enabled (same as V7)	Default: 0 Range: 0, 1	243
F6-08 (36A) <I>	Reset Communication Parameters	All Modes 0: Communication-related parameters (F6-□□) are not reset when the drive is initialized using A1-03. 1: Reset all communication-related parameters (F6-□□) when the drive is initialized using A1-03.	Default: 0 Range: 0, 1	243
F6-10 (3B6)	CC-Link Node Address	All Modes Sets the node address if a CC-Link option is installed.	Default: 0 Min.: 0 Max.: 64	243
F6-11 (3B7)	CC-Link Communication Speed	All Modes 0: 156 Kbps 1: 625 Kbps 2: 2.5 Mbps 3: 5 Mbps 4: 10 Mbps	Default: 0 Range: 0 to 4	243
F6-14 (3BB)	CC-Link bUS Error Auto Reset	All Modes 0: Disabled 1: Enabled	Default: 0 Range: 0, 1	243
F6-20 (36B)	MECHATROLINK Station Address	All Modes Sets the station address when the MECHATROLINK-II option has been installed.	Default: 21 Min.: 20 Max.: 3F	—
F6-21 (36C)	MECHATROLINK Frame Size	All Modes 0: 32 byte 1: 17 byte	Default: 0 Range: 0, 1	—
F6-22 (36D)	MECHATROLINK Link Speed	All Modes 0: 10 Mbps 1: 4 Mbps	Default: 0 Range: 0, 1	—
F6-23 (36E)	MECHATROLINK Monitor Selection (E)	All Modes Sets the MECHATROLINK-II monitor (E).	Default: 0 Min.: 0 Max.: FFFF	—

No. (Addr. Hex)	Name	Description	Values	Page
F6-24 (36F)	MECHATROLINK Monitor Selection (F)	All Modes Sets the MECHATROLINK-II monitor (F).	Default: 0 Min.: 0 Max.: FFFF	—
F6-25 (3C9)	Operation Selection at Watchdog Timer Error (E5)	All Modes 0: Ramp to stop. Decelerate using the deceleration time in C1-02. 1: Coast to stop 2: Fast stop. Decelerate using the deceleration time in C1-09. 3: Alarm only	Default: 1 Range: 0 to 3	—
F6-26 (3CA)	MECHATROLINK bUS Errors Detected	All Modes Sets the number of option communication errors (bUS).	Default: 2 Min.: 2 Max.: 10	—
F6-30 (3CB)	PROFIBUS-DP Node Address	All Modes Sets the node address.	Default: 0 Min.: 0 Max.: 125	244
F6-31 (3CC)	PROFIBUS-DP Clear Mode Selection	All Modes 0: Resets drive operation with a Clear mode command. 1: Maintains the previous operation state when Clear mode command is given.	Default: 0 Range: 0, 1	244
F6-32 (3CD)	PROFIBUS-DP Data Format Selection	All Modes 0: PPO Type 1: Conventional	Default: 0 Range: 0, 1	244
F6-35 (3D0)	CANopen Node ID Selection	All Modes Sets the node address.	Default: 0 Min.: 0 Max.: 126	244
F6-36 (3D1)	CANopen Communication Speed	All Modes 0: Auto-detection 1: 10 kbps 2: 20 kbps 3: 50 kbps 4: 125 kbps 5: 250 kbps 6: 500 kbps 7: 800 kbps 8: 1 Mbps	Default: 6 Range: 0 to 8	244
F6-50 (3C1)	DeviceNet MAC Address	All Modes Selects the drive MAC address.	Default: 64 Min.: 0 Max.: 64	245
F6-51 (3C2)	DeviceNet Communication Speed	All Modes 0: 125 kbps 1: 250 kbps 2: 500 kbps 3: Adjustable from network 4: Detect automatically	Default: 4 Range: 0 to 4	245
F6-52 (3C3)	DeviceNet PCA Setting	All Modes Sets the format of the data set from the DeviceNet master to the drive.	Default: 21 Min.: 0 Max.: 255	245
F6-53 (3C4)	DeviceNet PPA Setting	All Modes Sets the format of the data set from the drive to the DeviceNet master.	Default: 71 Min.: 0 Max.: 255	245
F6-54 (3C5)	DeviceNet Idle Mode Fault Detection	All Modes 0: Enabled 1: Disabled, no fault detection	Default: 0 Range: 0, 1	245
F6-55 (3C6)	DeviceNet Baud Rate Monitor	All Modes Verifies the baud rate running on the network. 0: 125 kbps 1: 250 kbps 2: 500 kbps	Default: 0 Range: 0 to 2	245
F6-56 (3D7)	DeviceNet Speed Scaling	All Modes Sets the scaling factor for the speed monitor in DeviceNet.	Default: 0 Min.: -15 Max.: 15	246

B.8 F: Options

No. (Addr. Hex)	Name	Description	Values	Page
F6-57 (3D8)	DeviceNet Current Scaling	All Modes Sets the scaling factor for the output current monitor in DeviceNet.	Default: 0 Min.: -15 Max.: 15	246
F6-58 (3D9)	DeviceNet Torque Scaling	All Modes Sets the scaling factor for the torque monitor in DeviceNet.	Default: 0 Min.: -15 Max.: 15	246
F6-59 (3DA)	DeviceNet Power Scaling	All Modes Sets the scaling factor for the power monitor in DeviceNet.	Default: 0 Min.: -15 Max.: 15	246
F6-60 (3DB)	DeviceNet Voltage Scaling	All Modes Sets the scaling factor for the voltage monitor in DeviceNet.	Default: 0 Min.: -15 Max.: 15	246
F6-61 (3DC)	DeviceNet Time Scaling	All Modes Sets the scaling factor for the time monitor in DeviceNet.	Default: 0 Min.: -15 Max.: 15	246
F6-62 (3DD)	DeviceNet Heartbeat Interval	All Modes Sets the heartbeat interval for DeviceNet communications.	Default: 0 Min.: 0 Max.: 10	246
F6-63 (3DE)	DeviceNet Network MAC ID	All Modes Saves and monitors settings 0 to 63 of F6-50 (DeviceNet MAC Address).	Default: 63 Min.: 0 Max.: 63	246
F6-64 to F6-71 (3DF to 3C8)	Reserved	All Modes Reserved for Dynamic I/O Assembly Parameters.	–	–
F7-01 (3E5) <2>	IP Address 1	All Modes Sets the most significant octet of network static IP address.	Default: 192 Range: 0 to 255	–
F7-02 (3E6) <2>	IP Address 2	All Modes Sets the second most significant octet of network static IP address.	Default: 168 Range: 0 to 255	–
F7-03 (3E7) <2>	IP Address 3	All Modes Sets the third most significant octet of network static IP address.	Default: 1 Range: 0 to 255	–
F7-04 (3E8) <2>	IP Address 4	All Modes Sets the fourth most significant octet of network static IP address.	Default: 20 Range: 0 to 255	–
F7-05 (3E9)	Subnet Mask 1	All Modes Sets the most significant octet of network static Subnet Mask.	Default: 255 Range: 0 to 255	–
F7-06 (3EA)	Subnet Mask 2	All Modes Sets the second most significant octet of network static Subnet Mask.	Default: 255 Range: 0 to 255	–
F7-07 (3EB)	Subnet Mask 3	All Modes Sets the third most significant octet of network static Subnet Mask.	Default: 255 Range: 0 to 255	–
F7-08 (3EC)	Subnet Mask 4	All Modes Sets the fourth most significant octet of network static Subnet Mask.	Default: 0 Range: 0 to 255	–
F7-09 (3ED)	Gateway Address 1	All Modes Sets the most significant octet of network Gateway address.	Default: 192 Range: 0 to 255	–
F7-10 (3EE)	Gateway Address 2	All Modes Sets the second most significant octet of network Gateway address.	Default: 168 Range: 0 to 255	–
F7-11 (3EF)	Gateway Address 3	All Modes Sets the third most significant octet of network Gateway address.	Default: 1 Range: 0 to 255	–
F7-12 (3E0)	Gateway Address 4	All Modes Sets the fourth most significant octet of network Gateway address.	Default: 1 Range: 0 to 255	–

No. (Addr. Hex)	Name	Description	Values	Page
F7-13 (3F1)	Address Mode at Startup	All Modes Select the option address setting method 0: Static <2> 1: BOOTP 2: DHCP	Default: 2 Range: 0 to 2	–
F7-14 (3F2)	Duplex Mode Selection	All Modes Selects duplex mode setting. 0: Half duplex forced 1: Auto-negotiate duplex mode and communication speed 2: Full duplex forced	Default: 1 Range: 0 to 2	–
F7-15 (3F3)	Communication Speed Selection	All Modes Sets the communication speed 10: 10 Mbps 100: 100 Mbps	Default: 10 Range: 10, 100	–
F7-16 (3F4)	Communication Loss Timeout	All Modes Sets the timeout value for communication loss detection in tenths of a second. A value of 0 disables the connection timeout. Example: An entered value of 100 represents 10.0 seconds.	Default: 0 Min.: 0 Max.: 300	–
F7-17 (3F5)	EtherNet/IP Speed Scaling Factor	All Modes Sets the scaling factor for the speed monitor in EtherNet/IP Class ID 2AH Object.	Default: 0 Min.: -15 Max.: 15	–
F7-18 (3F6)	EtherNet/IP Current Scaling Factor	All Modes Sets the scaling factor for the output current monitor in EtherNet/IP Class ID 2AH Object.	Default: 0 Min.: -15 Max.: 15	–
F7-19 (3F7)	EtherNet/IP Torque Scaling Factor	All Modes Sets the scaling factor for the torque monitor in EtherNet/IP Class ID 2AH Object.	Default: 0 Min.: -15 Max.: 15	–
F7-20 (3F8)	EtherNet/IP Power Scaling Factor	All Modes Sets the scaling factor for the power monitor in EtherNet/IP Class ID 2AH Object.	Default: 0 Min.: -15 Max.: 15	–
F7-21 (3F9)	EtherNet/IP Voltage Scaling Factor	All Modes Sets the scaling factor for the voltage monitor in EtherNet/IP Class ID 2AH Object.	Default: 0 Min.: -15 Max.: 15	–
F7-22 (3FA)	EtherNet/IP Time Scaling	All Modes Sets the scaling factor for the time monitor in EtherNet/IP Class ID 2AH Object.	Default: 0 Min.: -15 Max.: 15	–
F7-23 to F7-32 (3FB to 374)	Dynamic Output Assembly Parameters	All Modes Parameters used in Output Assembly 116. Each parameter contains a MEMOBUS/Modbus address. The value received for Output Assembly 116 will be written to this corresponding MEMOBUS/Modbus address. A MEMOBUS/Modbus address value of 0 means that the value received for Output Assembly 116 will not be written to any MEMOBUS/Modbus register.	Default: 0	–
F7-33 to F7-42 (375 to 37E)	Dynamic Input Assembly Parameters	All Modes Parameters used in Input Assembly 166. Each parameter contains a MEMOBUS/Modbus address. The value sent for Input Assembly 166 will be read from this corresponding MEMOBUS/Modbus address. A MEMOBUS/Modbus address value of 0 means that the value sent for Input Assembly 166 is not defined by the user, therefore the option default register value will be returned.	Default: 0	–

<1> Parameter setting value is not reset to the default value when the drive is initialized.

<2> Cycle power for setting changes to take effect.

<3> If F7-13 is set to 0, all IP addresses (F7-01 to F7-04) must be unique.

B.9 H Parameters: Multi-Function Terminals

H parameters assign functions to the multi-function input and output terminals.

◆ H1: Multi-Function Digital Inputs

No. (Addr. Hex)	Name	Description	Values	Page
H1-01 (438)	Multi-Function Digital Input Terminal S1 Function Selection	All Modes Assigns a function to the multi-function digital inputs. Refer to pages 528 to 532 for descriptions of setting values. Note: Set unused terminals to F.	Default: 40 (F) <1> Min.: 1 Max.: 9F	247
H1-02 (439)	Multi-Function Digital Input Terminal S2 Function Selection	All Modes Assigns a function to the multi-function digital inputs. Refer to pages 528 to 532 for descriptions of setting values. Note: Set unused terminals to F.	Default: 41 (F) <1> Min.: 1 Max.: 9F	247
H1-03 (400)	Multi-Function Digital Input Terminal S3 Function Selection	All Modes Assigns a function to the multi-function digital inputs. Refer to pages 528 to 532 for descriptions of setting values. Note: Set unused terminals to F.	Default: 24 Min.: 0 Max.: 9F	247
H1-04 (401)	Multi-Function Digital Input Terminal S4 Function Selection	All Modes Assigns a function to the multi-function digital inputs. Refer to pages 528 to 532 for descriptions of setting values. Note: Set unused terminals to F.	Default: 14 Min.: 0 Max.: 9F	247
H1-05 (402)	Multi-Function Digital Input Terminal S5 Function Selection	All Modes Assigns a function to the multi-function digital inputs. Refer to pages 528 to 532 for descriptions of setting values. Note: Set unused terminals to F.	Default: 3 (0) <1> Min.: 0 Max.: 9F	247
H1-06 (403)	Multi-Function Digital Input Terminal S6 Function Selection	All Modes Assigns a function to the multi-function digital inputs. Refer to pages 528 to 532 for descriptions of setting values. Note: Set unused terminals to F.	Default: 4 (3) <1> Min.: 0 Max.: 9F	247
H1-07 (404)	Multi-Function Digital Input Terminal S7 Function Selection	All Modes Assigns a function to the multi-function digital inputs. Refer to pages 528 to 532 for descriptions of setting values. Note: Set unused terminals to F.	Default: 6 (4) <1> Min.: 0 Max.: 9F	247
H1-08 (405)	Multi-Function Digital Input Terminal S8 Function Selection	All Modes Assigns a function to the multi-function digital inputs. Refer to pages 528 to 532 for descriptions of setting values. Note: Set unused terminals to F.	Default: 8 Min.: 0 Max.: 9F	247

<1> Value in parenthesis is the default setting when a 3-Wire initialization is performed (A1-03 = 3330).

H1 Multi-Function Digital Input Selections			
H1-□□ Setting	Function	Description	Page
0	3-Wire sequence	All Modes Closed: Reverse rotation (only if the drive is set up for 3-Wire sequence) Terminals S1 and S2 are automatically set up for the Run command and Stop command.	248
1	LOCAL/REMOTE selection	All Modes Open: REMOTE (parameter settings determine the source of the frequency Reference 1 or 2 (b1-01, b1-02 or b1-15, b1-16) Closed: LOCAL, Frequency reference and Run command are input from the digital operator.	248
2	External reference 1/2 selection	All Modes Open: Run command and frequency reference source 1 (determined by b1-01 and b1-02) Closed: Run command and frequency reference source 2 (determined by b1-15 and b1-16)	249

H1 Multi-Function Digital Input Selections			
H1-□□ Setting	Function	Description	Page
3	Multi-Step Speed Reference 1	All Modes When input terminals are set to Multi-Step Speed References 1 through 3, switching combinations of those terminals will create a multi-step speed sequence using the frequency references set in d1-01 through d1-08.	249
4	Multi-Step Speed Reference 2	All Modes When input terminals are set to Multi-Step Speed References 1 through 3, switching combinations of those terminals will create a multi-step speed sequence using the frequency references set in d1-01 through d1-08.	249
5	Multi-Step Speed Reference 3	All Modes When input terminals are set to Multi-Step Speed References 1 through 3, switching combinations of those terminals will create a multi-step speed sequence using the frequency references set in d1-01 through d1-08.	249
6	Jog reference selection	All Modes Closed: Jog frequency reference (d1-17) selected. Jog has priority over all other reference sources.	249
7	Accel/decel time selection 1	All Modes Used to switch between accel/decel time 1 (set in C1-01, C1-02) and accel/decel time 2 (set in C1-03, C1-04).	249
8	Baseblock command (N.O.)	All Modes Closed: No drive output	249
9	Baseblock command (N.C.)	All Modes Open: No drive output	249
A	Accel/decel ramp hold	All Modes Open: Accel/decel is not held Closed: The drive pauses during acceleration or deceleration and maintains the output frequency.	249
B	Drive overheat alarm (oH2)	All Modes Closed: Closes when an oH2 alarm occurs	250
C	Analog terminal input selection	All Modes Open: Function assigned by H3-14 is disabled. Closed: Function assigned by H3-14 is enabled.	250
D	PG encoder disable	<input type="radio"/> V/f <input checked="" type="radio"/> V/f w PG <input type="radio"/> OLV <input type="radio"/> CLV <input type="radio"/> OLV/PM <input type="radio"/> AOLV/PM <input type="radio"/> CLV/PM Open: Speed feedback for V/f Control with PG is enabled. Closed: Speed feedback disabled.	250
E	ASR integral reset	<input type="radio"/> V/f <input checked="" type="radio"/> V/f w PG <input type="radio"/> OLV <input checked="" type="radio"/> CLV <input type="radio"/> OLV/PM <input type="radio"/> AOLV/PM <input checked="" type="radio"/> CLV/PM Open: PI control Closed: Integral reset	250
F	Through mode	All Modes Select this setting when using the terminal in a pass-through mode. The terminal does not trigger a drive function but can be used as digital input for the controller the drive is connected to.	250
10	Up command	All Modes The drive accelerates when the Up command terminal closes, and decelerates when the Down command closes. When both terminals are closed or both are open, the drive holds the frequency reference. The Up and Down commands must always be used in conjunction with one another.	250
11	Down command	All Modes The drive accelerates when the Up command terminal closes, and decelerates when the Down command closes. When both terminals are closed or both are open, the drive holds the frequency reference. The Up and Down commands must always be used in conjunction with one another.	250
12	Forward Jog	All Modes Closed: Runs forward at the Jog frequency d1-17.	251

B.9 H Parameters: Multi-Function Terminals

H1 Multi-Function Digital Input Selections			
H1-□□ Setting	Function	Description	Page
13	Reverse Jog	All Modes Closed: Runs reverse at the Jog frequency d1-17.	251
14	Fault reset	All Modes Closed: Resets faults if the cause is cleared and the Run command is removed.	251
15	Fast Stop (N.O.)	All Modes Closed: Decelerates at the Fast Stop time set to C1-09.	251
16	Motor 2 selection	V/f V/f w PG OLV CLV OLV/PM AOLV/PM CLV/PM Open: Motor 1 (E1-□□, E2-□□) Closed: Motor 2 (E3-□□, E4-□□)	252
17	Fast Stop (N.C.)	All Modes Open: Decelerates to stop at the Fast Stop time set to C1-09.	251
18	Timer function input	All Modes Triggers the timer set up by parameters b4-01 and b4-02. Must be set in conjunction with the timer function output (H2-□□ = 12).	252
19	PID disable	All Modes Open: PID control enabled Closed: PID control disabled	253
1A	Accel/decel time selection 2	All Modes Used in conjunction with an input terminal set for “Accel/decel time selection 1” (H1-□□ = 7), and allows the drive to switch between accel/decel times 3 and 4.	253
1B	Program lockout	All Modes Open: Parameters cannot be edited (except for U1-01 if the reference source is assigned to the digital operator). Closed: Parameters can be edited and saved.	253
1E	Reference sample hold	All Modes Closed: Samples the analog frequency reference and operates the drive at that speed.	253
20 to 2F	External fault	All Modes 20: N.O., Always detected, ramp to stop 21: N.C., Always detected, ramp to stop 22: N.O., During run, ramp to stop 23: N.C., During run, ramp to stop 24: N.O., Always detected, coast to stop 25: N.C., Always detected, coast to stop 26: N.O., During run, coast to stop 27: N.C., During run, coast to stop 28: N.O., Always detected, Fast Stop 29: N.C., Always detected, Fast Stop 2A: N.O., During run, Fast Stop 2B: N.C., During run, Fast Stop 2C: N.O., Always detected, alarm only (continue running) 2D: N.C., Always detected, alarm only (continue running) 2E: N.O., During run, alarm only (continue running) 2F: N.C., During run, alarm only (continue running)	253
30	PID integral reset	All Modes Closed: Resets the PID control integral value.	254
31	PID integral hold	All Modes Open: Performs integral operation. Closed: Maintains the current PID control integral value.	254
32	Multi-Step Speed Reference 4	All Modes Used in combination with input terminals set to Multi-Step Speed Reference 1, 2, and 3. Use parameters d1-09 to d1-16 to set reference values.	254
34	PID soft starter cancel	All Modes Open: PID soft starter is enabled. Closed: Disables the PID soft starter b5-17.	254

H1 Multi-Function Digital Input Selections			
H1-□□ Setting	Function	Description	Page
35	PID input level selection	All Modes Closed: Inverts the PID input signal.	254
40	Forward run command (2-Wire sequence)	All Modes Open: Stop Closed: Forward run Note: Cannot be set together with settings 42 or 43.	254
41	Reverse run command (2-Wire sequence)	All Modes Open: Stop Closed: Reverse run Note: Cannot be set together with settings 42 or 43.	254
42	Run command (2-Wire sequence 2)	All Modes Open: Stop Closed: Run Note: Cannot be set together with settings 40 or 41.	255
43	FWD/REV command (2-Wire sequence 2)	All Modes Open: Forward Closed: Reverse Note: Determines motor direction, but does not issue a Run command. Cannot be set together with settings 40 or 41.	255
44	Offset frequency 1	All Modes Closed: Adds d7-01 to the frequency reference.	255
45	Offset frequency 2	All Modes Closed: Adds d7-02 to the frequency reference.	255
46	Offset frequency 3	All Modes Closed: Adds d7-03 to the frequency reference.	255
47	Node setup	All Modes Closed: Node setup for SI-S3 enabled.	255
60	DC Injection Braking command	V/f V/f w PG OLV CLV OLV/PM AOLV/PM CLV/PM Closed: Triggers DC Injection Braking.	255
61	External Speed Search command 1	V/f V/f w PG OLV CLV OLV/PM AOLV/PM CLV/PM Closed: Activates Current Detection Speed Search from the maximum output frequency (E1-04).	255
62	External Speed Search command 2	V/f V/f w PG OLV CLV OLV/PM AOLV/PM CLV/PM Closed: Activates Current Detection Speed Search from the frequency reference.	255
63	Field weakening	V/f V/f w PG OLV CLV OLV/PM AOLV/PM CLV/PM Closed: The drive performs Field Weakening control as set for d6-01 and d6-02.	255
65	KEB Ride-Thru 1 (N.C.)	All Modes Open: KEB Ride-Thru 1 enabled.	255
66	KEB Ride-Thru 1 (N.O.)	All Modes Closed: KEB Ride-Thru 1 enabled.	255
67	Communications test mode	All Modes Tests the MEMOBUS/Modbus RS-422/RS-485 interface. Displays "PASS" if the test completes successfully.	256
68	High Slip Braking (HSB)	V/f V/f w PG OLV CLV OLV/PM AOLV/PM CLV/PM Closed: Activates High Slip Braking to stop the drive during a Run command.	256

B.9 H Parameters: Multi-Function Terminals

H1 Multi-Function Digital Input Selections			
H1-□□ Setting	Function	Description	Page
6A	Drive enable	<p>All Modes</p> <p>Open: Drive disabled. If this input is opened during run, the drive will stop as specified by b1-03. Closed: Ready for operation.</p>	256
71	Speed/Torque control Sswitch	<p> <input type="radio"/> V/f <input type="radio"/> V/f w PG <input type="radio"/> OLV <input checked="" type="radio"/> CLV <input type="radio"/> OLV/PM <input type="radio"/> AOLV/PM <input checked="" type="radio"/> CLV/PM </p> <p>Open: Speed Control Closed: Torque Control</p>	256
72	Zero servo	<p> <input type="radio"/> V/f <input type="radio"/> V/f w PG <input type="radio"/> OLV <input checked="" type="radio"/> CLV <input type="radio"/> OLV/PM <input type="radio"/> AOLV/PM <input checked="" type="radio"/> CLV/PM </p> <p>Closed: Zero Servo enabled</p>	256
75	Up 2 command	<p>All Modes</p> <p>Used to control the bias added to the frequency reference by the Up/Down 2 function. The Up 2 and Down 2 commands must always be used in conjunction with one another.</p>	256
76	Down 2 command	<p>All Modes</p> <p>Used to control the bias added to the frequency reference by the Up/Down 2 function. The Up 2 and Down 2 commands must always be used in conjunction with one another.</p>	256
77	ASR gain switch	<p> <input type="radio"/> V/f <input type="radio"/> V/f w PG <input type="radio"/> OLV <input checked="" type="radio"/> CLV <input type="radio"/> OLV/PM <input checked="" type="radio"/> AOLV/PM <input checked="" type="radio"/> CLV/PM </p> <p>Open: ASR proportional gain 1 (C5-01) Closed: ASR proportional gain 2 (C5-03)</p>	257
78	External torque reference polarity inversion	<p> <input type="radio"/> V/f <input type="radio"/> V/f w PG <input type="radio"/> OLV <input checked="" type="radio"/> CLV <input type="radio"/> OLV/PM <input type="radio"/> AOLV/PM <input checked="" type="radio"/> CLV/PM </p> <p>Open: Forward torque reference. Closed: Reverse polarity.</p>	257
7A	KEB Ride-Thru 2 (N.C.)	<p>All Modes</p> <p>Open: KEB Ride-Thru 2 enabled. Drive disregards L2-29 and performs Single Drive KEB Ride-Thru 2.</p>	257
7B	KEB Ride-Thru 2 (N.O.)	<p>All Modes</p> <p>Closed: KEB Ride-Thru 2 enabled. Drive disregards L2-29 and performs Single Drive KEB Ride-Thru 2.</p>	257
7C	Short circuit braking (N.O.)	<p> <input type="radio"/> V/f <input type="radio"/> V/f w PG <input type="radio"/> OLV <input type="radio"/> CLV <input checked="" type="radio"/> OLV/PM <input checked="" type="radio"/> AOLV/PM <input type="radio"/> CLV/PM </p> <p>Closed: Short Circuit Braking enabled</p>	257
7D	Short circuit braking (N.C.)	<p> <input type="radio"/> V/f <input type="radio"/> V/f w PG <input type="radio"/> OLV <input type="radio"/> CLV <input checked="" type="radio"/> OLV/PM <input checked="" type="radio"/> AOLV/PM <input type="radio"/> CLV/PM </p> <p>Open: Short Circuit Braking enabled</p>	257
7E	Forward/reverse detection (V/f Control with Simple PG feedback)	<p> <input type="radio"/> V/f <input checked="" type="radio"/> V/f w PG <input type="radio"/> OLV <input type="radio"/> CLV <input type="radio"/> OLV/PM <input type="radio"/> AOLV/PM <input type="radio"/> CLV/PM </p> <p>Direction of rotation detection (for V/f with Simple PG Feedback)</p>	258
90 to 97	DriveWorksEZ digital inputs 1 to 8	<p>All Modes</p> <p>Reserved for DWEZ input functions</p>	258
9F	DriveWorksEZ disable	<p>All Modes</p> <p>Open: DWEZ enabled Closed: DWEZ disabled</p>	258

◆ H2: Multi-Function Digital Outputs

No. (Addr. Hex)	Name	Description	Values	Page
H2-01 (40B)	Terminal M1-M2 function selection (relay)	All Modes Refer to H2 Multi-Function Digital Output Settings on pages 533 to 536 for descriptions of setting values.	Default: 0 Range: 0 to 192	258
H2-02 (40C)	Terminal M3-M4 function selection (relay)		Default: 1 Range: 0 to 192	258
H2-03 (40D)	Terminal M5-M6 function selection (relay)		Default: 2 Range: 0 to 192	258
H2-06 (437)	Watt Hour Output Unit Selection	All Modes Outputs a 200 ms pulse signal when the watt-hour counter increases by the units selected. 0: 0.1 kWh units 1: 1 kWh units 2: 10 kWh units 3: 100 kWh units 4: 1000 kWh units	Default: 0 Range: 0 to 4	268

H2 Multi-Function Digital Output Settings			
H2-□□ Setting	Function	Description	Page
0	During run	All Modes Closed: A Run command is active or voltage is output.	259
1	Zero speed	All Modes Open: Output frequency is above the minimum output frequency set in E1-09. Closed: Output frequency is below the minimum output frequency set in E1-09.	259
2	Speed agree 1	All Modes Closed: Output frequency equals the speed reference (plus or minus the hysteresis set to L4-02).	259
3	User-set speed agree 1	All Modes Closed: Output frequency and speed reference equal L4-01 (plus or minus the hysteresis set to L4-02).	260
4	Frequency detection 1	All Modes Closed: Output frequency is less than or equal to the value in L4-01 with hysteresis determined by L4-02.	260
5	Frequency detection 2	All Modes Closed: Output frequency is greater than or equal to the value in L4-01 with hysteresis determined by L4-02.	261
6	Drive ready	All Modes Closed: Power up is complete and the drive is ready to accept a Run command.	261
7	DC bus undervoltage	All Modes Closed: DC bus voltage is below the Uv trip level set in L2-05.	261
8	During baseblock (N.O.)	All Modes Closed: Drive has entered the baseblock state (no output voltage).	262
9	Frequency reference source	All Modes Open: External Reference 1 or 2 supplies the frequency reference (set in b1-01 or b1-15). Closed: Digital operator supplies the frequency reference.	262
A	Run command source	All Modes Open: External Reference 1 or 2 supplies the Run command (set in b1-02 or b1-16). Closed: Digital operator supplies the Run command.	262
B	Torque detection 1 (N.O.)	All Modes Closed: An overtorque or undertorque situation has been detected.	262
C	Frequency reference loss	All Modes Closed: Analog frequency reference has been lost. Frequency reference loss is detected when the frequency reference drops below 10% of the reference within 400 ms.	262

B.9 H Parameters: Multi-Function Terminals







H2 Multi-Function Digital Output Settings			
H2-□□ Setting	Function	Description	Page
D	Braking resistor fault	All Modes Closed: Braking resistor or transistor is overheated or faulted out. Note: This function is not available in models 4A0930 and 4A1200.	262
E	Fault	All Modes Closed: Fault occurred.	262
F	Through mode	All Modes Set this value when using the terminal in the pass-through mode.	262
10	Minor fault	All Modes Closed: An alarm has been triggered, or the IGBTs have reached 90% of their expected life span.	262
11	Fault reset command active	All Modes Closed: A command has been entered to clear a fault via the input terminals or from the serial network.	262
12	Timer output	All Modes Closed: Timer output.	263
13	Speed agree 2	All Modes Closed: When drive output frequency equals the frequency reference $\pm L4-04$.	263
14	User-set speed agree 2	All Modes Closed: When the drive output frequency is equal to the value in L4-03 $\pm L4-04$.	263
15	Frequency detection 3	All Modes Closed: When the drive output frequency is less than or equal to the value in L4-03 $\pm L4-04$.	264
16	Frequency detection 4	All Modes Closed: When the output frequency is greater than or equal to the value in L4-03 $\pm L4-04$.	264
17	Torque detection 1 (N.C.)	All Modes Open: Overtorque or undertorque has been detected.	262
18	Torque detection 2 (N.O.)	All Modes Closed: Overtorque or undertorque has been detected.	
19	Torque detection 2 (N.C.)	All Modes Open: Overtorque or undertorque has been detected.	262
1A	During reverse	All Modes Closed: Drive is running in the reverse direction.	264
1B	During baseblock (N.C.)	All Modes Open: Drive has entered the baseblock state (no output voltage).	265
1C	Motor 2 selection	V/f V/f w PG OLV CLV OLV/PM AOLV/PM CLV/PM Closed: Motor 2 is selected by a digital input (H1-□□ = 16)	265
1D	During regeneration	V/f V/f w PG OLV CLV OLV/PM AOLV/PM CLV/PM Closed: Motor is regenerating energy into the drive.	265
1E	Restart enabled	All Modes Closed: An automatic restart is performed	265
1F	Motor overload alarm (oL1)	All Modes Closed: oL1 is at 90% of its trip point or greater. An oH3 situation also triggers this alarm.	265
20	Drive overheat pre-alarm (oH)	All Modes Closed: Heatsink temperature exceeds the parameter L8-02 value.	265
22	Mechanical weakening detection	All Modes Closed: Mechanical weakening detected.	265
2F	Maintenance period	All Modes Closed: Cooling fan, electrolytic capacitors, IGBTs, or the soft charge bypass relay may require maintenance.	265

H2 Multi-Function Digital Output Settings			
H2-□□ Setting	Function	Description	Page
30	During torque limit	<div style="display: flex; justify-content: space-between; align-items: center;"> V/f V/f w PG OLV CLV </div> <div style="display: flex; justify-content: space-between; align-items: center;"> OLV/PM AOLV/PM CLV/PM </div> <p>Closed: When the torque limit has been reached.</p>	265
31	During speed limit	<div style="display: flex; justify-content: space-between; align-items: center;"> V/f V/f w PG OLV CLV </div> <div style="display: flex; justify-content: space-between; align-items: center;"> OLV/PM AOLV/PM CLV/PM </div> <p>Closed: Speed limit has been reached.</p>	266
32	During speed limit in Torque Control	<div style="display: flex; justify-content: space-between; align-items: center;"> V/f V/f w PG OLV CLV </div> <div style="display: flex; justify-content: space-between; align-items: center;"> OLV/PM AOLV/PM CLV/PM </div> <p>Closed: Speed limit has been reached while using Torque Control.</p>	266
33	Zero Servo complete	<div style="display: flex; justify-content: space-between; align-items: center;"> V/f V/f w PG OLV CLV </div> <div style="display: flex; justify-content: space-between; align-items: center;"> OLV/PM AOLV/PM CLV/PM </div> <p>Closed: Zero Servo operation has finished.</p>	266
37	During frequency output	<p>All Modes</p> <p>Open: Either the drive has stopped or baseblock, DC Injection Braking, or Initial Excitation is being performed. Closed: Drive is running the motor (not in a baseblock state and DC Injection is not being performed).</p>	266
38	Drive enabled	<p>All Modes</p> <p>Closed: Multi-function input set for “Drive enable” is closed (H1-□□ = 6A)</p>	266
39	Watt hour pulse output	<p>All Modes</p> <p>Output units are determined by H2-06. Outputs a pulse every 200 ms to indicate the kWh count.</p>	266
3C	LOCAL/REMOTE status	<p>All Modes</p> <p>Open: REMOTE Closed: LOCAL</p>	266
3D	During speed search	<div style="display: flex; justify-content: space-between; align-items: center;"> V/f V/f w PG OLV CLV </div> <div style="display: flex; justify-content: space-between; align-items: center;"> OLV/PM AOLV/PM CLV/PM </div> <p>Closed: Speed Search is being executed.</p>	267
3E	PID feedback low	<p>All Modes</p> <p>Closed: PID feedback level is too low.</p>	267
3F	PID feedback high	<p>All Modes</p> <p>Closed: The PID feedback level is too high.</p>	267
4A	During KEB Ride-Thru	<p>All Modes</p> <p>Closed: KEB Ride-Thru is being performed.</p>	267
4B	During short circuit braking	<div style="display: flex; justify-content: space-between; align-items: center;"> V/f V/f w PG OLV CLV </div> <div style="display: flex; justify-content: space-between; align-items: center;"> OLV/PM AOLV/PM CLV/PM </div> <p>Closed: Short Circuit Braking is active.</p>	267
4C	During fast stop	<p>All Modes</p> <p>Closed: A Fast Stop command has been entered from the operator or input terminals.</p>	267
4D	oH Pre-alarm time limit	<p>All Modes</p> <p>Closed: oH pre-alarm time limit has passed.</p>	267
4E	Braking transistor fault (rr)	<p>All Modes</p> <p>Closed: The built-in dynamic braking transistor failed. Note: This function is not available in models 2A0169 to 2A0415 and 4A0088 to 4A1200.</p>	267
4F	Braking resistor overheat (oH)	<p>All Modes</p> <p>Closed: The dynamic braking resistor has overheated. Note: This function is not available in models 2A0169 to 2A0415 and 4A0088 to 4A1200.</p>	267
60	Internal cooling fan alarm	<p>All Modes</p> <p>Closed: Internal cooling fan alarm</p>	267

B.9 H Parameters: Multi-Function Terminals

H2 Multi-Function Digital Output Settings				
H2-□□ Setting	Function	Description		Page
61	Rotor position detection complete	<input type="checkbox"/> V/f <input type="checkbox"/> V/f w PG <input type="checkbox"/> OLV <input type="checkbox"/> CLV <input type="checkbox"/> OLV/PM <input checked="" type="checkbox"/> AOLV/PM <input checked="" type="checkbox"/> CLV/PM	Closed: Drive has successfully detected the rotor position of the PM motor.	267
90 to 92	DriveWorksEZ digital outputs 1 to 3	<input checked="" type="checkbox"/> All Modes	Reserved for DWEZ digital output functions.	267
100 to 192	Function 0 to 92 with inverse output	<input checked="" type="checkbox"/> All Modes	Inverts the output switching of the multi-function output functions. Set the last two digits of 1□□ to reverse the output signal of that specific function.	267

◆ H3: Multi-Function Analog Inputs

No. (Addr. Hex)	Name	Description	Values	Page
H3-01 (410)	Terminal A1 Signal Level Selection	<input checked="" type="checkbox"/> All Modes 0: 0 to 10 V 1: -10 to 10 V	Default: 0 Range: 0, 1	268
H3-02 (434)	Terminal A1 Function Selection	<input checked="" type="checkbox"/> All Modes Sets the function of terminal A1.	Default: 0 Range: 0 to 32	268
H3-03 (411) 	Terminal A1 Gain Setting	<input checked="" type="checkbox"/> All Modes Sets the level of the input value selected in H3-02 when 10 V is input at terminal A1.	Default: 100.0% Min.: -999.9 Max.: 999.9	269
H3-04 (412) 	Terminal A1 Bias Setting	<input checked="" type="checkbox"/> All Modes Sets the level of the input value selected in H3-02 when 0 V is input at terminal A1.	Default: 0.0% Min.: -999.9 Max.: 999.9	269
H3-05 (413)	Terminal A3 Signal Level Selection	<input checked="" type="checkbox"/> All Modes 0: 0 to 10 V 1: -10 to 10 V	Default: 0 Range: 0, 1	269
H3-06 (414)	Terminal A3 Function Selection	<input checked="" type="checkbox"/> All Modes Sets the function of terminal A3.	Default: 2 Range: 0 to 32	269
H3-07 (415) 	Terminal A3 Gain Setting	<input checked="" type="checkbox"/> All Modes Sets the level of the input value selected in H3-06 when 10 V is input at terminal A3.	Default: 100.0% Min.: -999.9 Max.: 999.9	270
H3-08 (416) 	Terminal A3 Bias Setting	<input checked="" type="checkbox"/> All Modes Sets the level of the input value selected in H3-06 when 0 V is input at terminal A3.	Default: 0.0% Min.: -999.9 Max.: 999.9	270
H3-09 (417)	Terminal A2 Signal Level Selection	<input checked="" type="checkbox"/> All Modes 0: 0 to 10 V 1: -10 to 10 V 2: 4 to 20 mA 3: 0 to 20 mA Note: Use DIP switch S1 to set input terminal A2 for a current or a voltage input signal.	Default: 2 Range: 0 to 3	270
H3-10 (418)	Terminal A2 Function Selection	<input checked="" type="checkbox"/> All Modes Sets the function of terminal A2.	Default: 0 Range: 0 to 32	270
H3-11 (419) 	Terminal A2 Gain Setting	<input checked="" type="checkbox"/> All Modes Sets the level of the input value selected in H3-10 when 10 V (20 mA) is input at terminal A2.	Default: 100.0% Min.: -999.9 Max.: 999.9	270
H3-12 (41A) 	Terminal A2 Bias Setting	<input checked="" type="checkbox"/> All Modes Sets the level of the input value selected in H3-10 when 0 V (0 or 4 mA) is input at terminal A2.	Default: 0.0% Min.: -999.9 Max.: 999.9	270
H3-13 (41B)	Analog Input Filter Time Constant	<input checked="" type="checkbox"/> All Modes Sets a primary delay filter time constant for terminals A1, A2, and A3. Used for noise filtering.	Default: 0.03 s Min.: 0.00 Max.: 2.00	271

No. (Addr. Hex)	Name	Description	Values	Page
H3-14 (41C)	Analog Input Terminal Enable Selection	All Modes Determines which analog input terminals will be enabled when a digital input programmed for “Analog input enable” (H1-□□ = C) is activated. 1: Terminal A1 only 2: Terminal A2 only 3: Terminals A1 and A2 only 4: Terminal A3 only 5: Terminals A1 and A3 6: Terminals A2 and A3 7: All terminals enabled	Default: 7 Range: 1 to 7	271
H3-16 (2F0)	Terminal A1 Offset	All Modes Adds an offset when the analog signal to terminal A1 is at 0 V.	Default: 0 Min.: -500 Max.: 500	272
H3-17 (2F1)	Terminal A2 Offset	All Modes Adds an offset when the analog signal to terminal A2 is at 0 V.	Default: 0 Min.: -500 Max.: 500	272
H3-18 (2F2)	Terminal A3 Offset	All Modes Adds an offset when the analog signal to terminal A3 is at 0 V.	Default: 0 Min.: -500 Max.: 500	272



H3 Multi-Function Analog Input Settings

H3-□□ Setting	Function	Description	Page
0	Frequency bias	All Modes 10 V = E1-04 (maximum output frequency)	272
1	Frequency gain	All Modes 0 to 10 V signal allows a setting of 0 to 100%. -10 to 0 V signal allows a setting of -100 to 0%.	272
2	Auxiliary frequency reference 1	All Modes 10 V = E1-04 (maximum output frequency)	272
3	Auxiliary frequency reference 2	All Modes 10 V = E1-04 (maximum output frequency)	272
4	Output voltage bias	V/f V/f w PG OLV CLV OLV/PM AOLV/PM CLV/PM 10 V = E1-05 (motor rated voltage)	272
5	Accel/decel time gain	All Modes 10 V = 100%	272
6	DC Injection Braking current	V/f V/f w PG OLV CLV OLV/PM AOLV/PM CLV/PM 10 V = Drive rated current	272
7	Overtorque/undertorque detection level	All Modes 10 V = Drive rated current (V/f, V/f w PG) 10 V = Motor rated torque (OLV, CLV, OLV/PM, AOLV/PM, CLV/PM)	273
8	Stall Prevention level during run	V/f V/f w PG OLV CLV OLV/PM AOLV/PM CLV/PM 10 V = Drive rated current	273
9	Output frequency lower limit level	All Modes 10 V = E1-04 (maximum output frequency)	273
B	PID feedback	All Modes 10 V = 100%	273
C	PID setpoint	All Modes 10 V = 100%	273
D	Frequency bias	All Modes 10 V = E1-04 (maximum output frequency)	273

B.9 H Parameters: Multi-Function Terminals

H3 Multi-Function Analog Input Settings			
H3-□□ Setting	Function	Description	Page
E	Motor temperature (PTC input)	All Modes 10 V = 100%	273
F	Through mode	All Modes Set this value when using the terminal in the pass-through mode.	273
10	Forward torque limit	<input type="button" value="V/f"/> <input type="button" value="V/f w PG"/> <input type="button" value="OLV"/> <input type="button" value="CLV"/> <input type="button" value="OLV/PM"/> <input type="button" value="AOLV/PM"/> <input type="button" value="CLV/PM"/> 10 V = Motor rated torque	273
11	Reverse torque limit	<input type="button" value="V/f"/> <input type="button" value="V/f w PG"/> <input type="button" value="OLV"/> <input type="button" value="CLV"/> <input type="button" value="OLV/PM"/> <input type="button" value="AOLV/PM"/> <input type="button" value="CLV/PM"/> 10 V = Motor rated torque	273
12	Regenerative torque limit	<input type="button" value="V/f"/> <input type="button" value="V/f w PG"/> <input type="button" value="OLV"/> <input type="button" value="CLV"/> <input type="button" value="OLV/PM"/> <input type="button" value="AOLV/PM"/> <input type="button" value="CLV/PM"/> 10 V = Motor rated torque	273
13	Torque reference/Torque limit	<input type="button" value="V/f"/> <input type="button" value="V/f w PG"/> <input type="button" value="OLV"/> <input type="button" value="CLV"/> <input type="button" value="OLV/PM"/> <input type="button" value="AOLV/PM"/> <input type="button" value="CLV/PM"/> 10 V = Motor rated torque	274
14	Torque compensation	<input type="button" value="V/f"/> <input type="button" value="V/f w PG"/> <input type="button" value="OLV"/> <input type="button" value="CLV"/> <input type="button" value="OLV/PM"/> <input type="button" value="AOLV/PM"/> <input type="button" value="CLV/PM"/> 10 V = Motor rated torque	274
15	General torque limit	<input type="button" value="V/f"/> <input type="button" value="V/f w PG"/> <input type="button" value="OLV"/> <input type="button" value="CLV"/> <input type="button" value="OLV/PM"/> <input type="button" value="AOLV/PM"/> <input type="button" value="CLV/PM"/> 10 V = Motor rated torque	273
16	Differential PID feedback	All Modes 10 V = 100%	274
17	Motor Thermistor (NTC)	All Modes 10 V = -9 °C 0 V = 234 °C Note: This function is only available in models 4A0930 and 4A1200.	274
1F	Through mode	All Modes Set this value when using the terminal in the pass-through mode.	273
30 to 32	DriveWorksEZ analog input 1 to 3	All Modes Output is determined by the function selected using DWEZ.	274

◆ H4: Analog Outputs

No. (Addr. Hex)	Name	Description	Values	Page
H4-01 (41D)	Multi-Function Analog Output Terminal FM Monitor Selection	All Modes Selects the data to be output through multi-function analog output terminal FM. Set the desired monitor parameter to the digits available in U□-□□. For example, enter "103" for U1-03.	Default: 102 Range: 000 to 999	274
H4-02 (41E) 	Multi-Function Analog Output Terminal FM Gain	All Modes Sets the signal level at terminal FM that is equal to 100% of the selected monitor value.	Default: 100.0% Min.: -999.9 Max.: 999.9	274
H4-03 (41F) 	Multi-Function Analog Output Terminal FM Bias	All Modes Sets the signal level at terminal FM that is equal to 0% of the selected monitor value.	Default: 0.0% Min.: -999.9 Max.: 999.9	274

No. (Addr. Hex)	Name	Description	Values	Page
H4-04 (420)	Multi-Function Analog Output Terminal AM Monitor Selection	All Modes Selects the data to be output through multi-function analog output terminal AM. Set the desired monitor parameter to the digits available in U□-□□. For example, enter “103” for U1-03.	Default: 103 Range: 000 to 999	274
H4-05 (421) ↕ RUN	Multi-Function Analog Output Terminal AM Gain	All Modes Sets the signal level at terminal AM that is equal to 100% of the selected monitor value.	Default: 50.0% Min.: -999.9 Max.: 999.9	274
H4-06 (422) ↕ RUN	Multi-Function Analog Output Terminal AM Bias	All Modes Sets the signal level at terminal AM that is equal to 0% of the selected monitor value.	Default: 0.0% Min.: -999.9 Max.: 999.9	274
H4-07 (423)	Multi-Function Analog Output Terminal FM Signal Level Selection	All Modes 0: 0 to 10 V 1: -10 to 10 V 2: 4 to 20 mA	Default: 0 Range: 0 to 2	275
H4-08 (424)	Multi-Function Analog Output Terminal AM Signal Level Selection	All Modes 0: 0 to 10 V 1: -10 to 10 V 2: 4 to 20 mA	Default: 0 Range: 0 to 2	275

◆ H5: MEMOBUS/Modbus Serial Communication







No. (Addr. Hex)	Name	Description	Values	Page
H5-01 (425) </>	Drive Node Address	All Modes Selects drive station node number (address) for MEMOBUS/Modbus terminals R+, R-, S+, S-. Cycle power for the setting to take effect.	Default: 1F (Hex) Min.: 0 Max.: FF	616
H5-02 (426)	Communication Speed Selection	All Modes 0: 1200 bps 1: 2400 bps 2: 4800 bps 3: 9600 bps 4: 19200 bps 5: 38400 bps 6: 57600 bps 7: 76800 bps 8: 115200 bps Cycle power for the setting to take effect.	Default: 3 Range: 0 to 8	616
H5-03 (427)	Communication Parity Selection	All Modes 0: No parity 1: Even parity 2: Odd parity Cycle power for the setting to take effect.	Default: 0 Range: 0 to 2	616
H5-04 (428)	Stopping Method after Communication Error (CE)	All Modes 0: Ramp to stop 1: Coast to stop 2: Fast Stop 3: Alarm only	Default: 3 Range: 0 to 3	616
H5-05 (429)	Communication Fault Detection Selection	All Modes 0: Disabled 1: Enabled. If communication is lost for more than two seconds, a CE fault will occur.	Default: 1 Range: 0, 1	616
H5-06 (42A)	Drive Transmit Wait Time	All Modes Set the wait time between receiving and sending data.	Default: 5 ms Min.: 5 Max.: 65	617
H5-07 (42B)	RTS Control Selection	All Modes 0: Disabled. RTS is always on. 1: Enabled. RTS turns on only when sending.	Default: 1 Range: 0, 1	617

B.9 H Parameters: Multi-Function Terminals

No. (Addr. Hex)	Name	Description	Values	Page
H5-09 (435)	CE Detection Time	All Modes Sets the time required to detect a communications error. Adjustment may be needed when networking several drives.	Default: 2.0 s Min.: 0.0 Max.: 10.0	617
H5-10 (436)	Unit Selection for MEMOBUS/Modbus Register 0025H	All Modes 0: 0.1 V units 1: 1 V units	Default: 0 Range: 0, 1	617
H5-11 (43C)	Communications ENTER Function Selection	All Modes 0: Drive requires an Enter command before accepting any changes to parameter settings. 1: Parameter changes are activated immediately without the Enter command (same as V7).	Default: 1 Range: 0, 1	618
H5-12 (43D)	Run Command Method Selection	All Modes 0: FWD/Stop, REV/Stop 1: Run/Stop, FWD/REV	Default: 0 Range: 0, 1	618

<1> If this parameter is set to 0, the drive will be unable to respond to MEMOBUS/Modbus commands.

◆ H6: Pulse Train Input/Output

No. (Addr. Hex)	Name	Description	Values	Page
H6-01 (42C)	Pulse Train Input Terminal RP Function Selection	All Modes 0: Frequency reference 1: PID feedback value 2: PID setpoint value 3: V/f Control with Simple PG feedback (possible only when using motor 1 in V/f Control)	Default: 0 Range: 0 to 3	276
H6-02 (42D) 	Pulse Train Input Scaling	All Modes Sets the terminal RP input signal frequency that is equal to 100% of the value selected in H6-01.	Default: 1440 Hz Min.: 100 Max.: 32000	277
H6-03 (42E) 	Pulse Train Input Gain	All Modes Sets the level of the value selected in H6-01 when a frequency with the value set in H6-02 is input.	Default: 100.0% Min.: 0.0 Max.: 1000.0	277
H6-04 (42F) 	Pulse Train Input Bias	All Modes Sets the level of the value selected in H6-01 when 0 Hz is input.	Default: 0.0% Min.: -100.0 Max.: 100.0	277
H6-05 (430) 	Pulse Train Input Filter Time	All Modes Sets the pulse train input filter time constant.	Default: 0.10 s Min.: 0.00 Max.: 2.00	277
H6-06 (431) 	Pulse Train Monitor Selection	All Modes Select the pulse train monitor output function (value of the □-□□ part of U□-□□). For example, enter “501” for U5-01.	Default: 102 Range: 000 to 809	278
H6-07 (432) 	Pulse Train Monitor Scaling	All Modes Sets the terminal MP output signal frequency when the monitor value is 100%. To have the pulse train monitor output equal the output frequency, set H6-06 to 102 and H6-07 to 0.	Default: 1440 Hz Min.: 0 Max.: 32000	278
H6-08 (43F)	Pulse Train Input Minimum Frequency	All Modes Sets the minimum frequency for the pulse train input to be detected. Enabled when H6-01 = 0, 1, or 2.	Default: 0.5 Hz Min.: 0.1 Max.: 1000.0	278

B.10 L: Protection Function

L parameters provide protection to the drive and motor, including control during momentary power loss, Stall Prevention, frequency detection, fault restarts, overtorque detection, and other types of hardware protection.

◆ L1: Motor Protection

No. (Addr. Hex)	Name	Description	Values	Page
L1-01 (480)	Motor Overload Protection Selection	All Modes 0: Disabled 1: General purpose motor (standard fan cooled) 2: Drive dedicated motor with a speed range of 1:10 3: Vector motor with a speed range of 1:100 4: PM motor with variable torque 5: PM motor with constant torque control 6: General purpose motor (50 Hz) The drive may not be able to provide protection when using multiple motors, even if overload is enabled in L1-01. Set L1-01 to 0 and install separate thermal relays to each motor.	Default: </> Range: 0 to 6	279
L1-02 (481)	Motor Overload Protection Time	All Modes Sets the motor thermal overload protection (oL1) time.	Default: 1.0 min Min.: 0.1 Max.: 5.0	281
L1-03 (482)	Motor Overheat Alarm Operation Selection (PTC input)	All Modes Sets operation when the motor temperature analog input (H3-02, H3-10, or H3-06 = E) exceeds the oH3 alarm level. 0: Ramp to stop 1: Coast to stop 2: Fast Stop (decelerate to stop using the deceleration time in C1-09) 3: Alarm only ("oH3" will flash)	Default: 3 Range: 0 to 3	283
L1-04 (483)	Motor Overheat Fault Operation Selection (PTC input)	All Modes Sets stopping method when the motor temperature analog input (H3-02, H3-10, or H3-06 = E) exceeds the oH4 fault level. 0: Ramp to stop 1: Coast to stop 2: Fast Stop (decelerate to stop using the deceleration time in C1-09)	Default: 1 Range: 0 to 2	283
L1-05 (484)	Motor Temperature Input Filter Time (PTC input)	All Modes Adjusts the filter for the motor temperature analog input (H3-02, H3-10, or H3-06 = E).	Default: 0.20 s Min.: 0.00 Max.: 10.00	283
L1-13 (46D)	Continuous Electrothermal Operation Selection	All Modes 0: Disabled 1: Enabled	Default: 1 Range: 0, 1	284
L1-15 (440)	Motor 1 Thermistor Selection (NTC)	All Modes 0: Disabled 1: Enabled Note: This parameter is only available in models 4A0930 and 4A1200.	Default: 0 Range: 0, 1	285
L1-16 (441)	Motor 1 Overheat Temperature	All Modes Sets the temperature for motor 1 that triggers an overheat fault (oH5). Note: This parameter is only available in models 4A0930 and 4A1200.	Default: 120 °C Min.: 50 Max.: 200	285
L1-17 (442)	Motor 2 Thermistor Selection (NTC)	All Modes 0: Disabled 1: Enabled Note: This parameter is only available in models 4A0930 and 4A1200.	Default: 0 Range: 0, 1	285
L1-18 (443)	Motor 2 Overheat Temperature	All Modes Sets the temperature for motor 1 that triggers an overheat fault (oH5). Note: This parameter is only available in models 4A0930 and 4A1200.	Default: 120 °C Min.: 50 Max.: 200	285

B.10 L: Protection Function

No. (Addr. Hex)	Name	Description	Values	Page
L1-19 (444)	Operation at Thermistor Disconnect (THo) (NTC)	<p>All Modes</p> <p>Determines drive response when a thermistor disconnect fault (THo) occurs.</p> <p>0: Ramp to stop 1: Coast to stop 2: Fast Stop (decelerate to stop using the deceleration time set to C1-09) 3: Alarm only (“THo” will flash)</p> <p>Note: This parameter is only available in models 4A0930 and 4A1200.</p>	Default: 3 Range: 0 to 3	285
L1-20 (445)	Operation at Motor Overheat (oH5)	<p>All Modes</p> <p>Determines drive response when a motor overheat fault (oH5) occurs.</p> <p>0: Ramp to stop 1: Coast to stop 2: Fast Stop (decelerate to stop using the deceleration time set to C1-09) 3: Alarm only (“oH5” will flash)</p> <p>Note: This parameter is only available in models 4A0930 and 4A1200.</p>	Default: 1 Range: 0 to 3	285

<1> Default setting is determined by parameter A1-02, Control Method Selection.

◆ L2: Momentary Power Loss Ride-Thru

No. (Addr. Hex)	Name	Description	Values	Page
L2-01 (485)	Momentary Power Loss Operation Selection	<p>All Modes</p> <p>0: Disabled. Drive trips on Uv1 fault when power is lost. 1: Recover within the time set in L2-02. Uv1 will be detected if power loss is longer than L2-02. 2: Recover as long as CPU has power. Uv1 is not detected. 3: KEB deceleration for the time set to L2-02. 4: KEB deceleration as long as CPU has power. 5: KEB deceleration to stop.</p>	Default: 0 Range: 0 to 5	286
L2-02 (486)	Momentary Power Loss Ride-Thru Time	<p>All Modes</p> <p>Sets the Power Loss Ride-Thru time. Enabled only when L2-01 = 1 or 3.</p>	Default: <1> Min.: 0.0 s Max.: 25.5 s	291
L2-03 (487)	Momentary Power Loss Minimum Baseblock Time	<p>All Modes</p> <p>Sets the minimum wait time for residual motor voltage decay before the drive output reenergizes after performing Power Loss Ride-Thru. Increasing the time set to L2-03 may help if overcurrent or overvoltage occur during Speed Search or during DC Injection Braking.</p> <p>Note: This parameter is not available in models 4A0930 and 4A1200.</p>	Default: <1> Min.: 0.1 s Max.: 5.0 s	291
L2-04 (488)	Momentary Power Loss Voltage Recovery Ramp Time	<p>V/f V/f w PG OLV CLV</p> <p>OLV/PM AOLV/PM CLV/PM</p> <p>Sets the time for the output voltage to return to the preset V/f pattern during Speed Search.</p>	Default: <1> Min.: 0.0 s Max.: 5.0 s	292
L2-05 (489)	Undervoltage Detection Level (Uv1)	<p>All Modes</p> <p>Sets the DC bus undervoltage trip level.</p>	Default: 190 Vdc <2> <3> Min.: 150 Vdc Max.: 210 Vdc <3>	292
L2-06 (48A)	KEB Deceleration Time	<p>All Modes</p> <p>Sets the time required to decelerate from the speed when KEB was activated to zero speed.</p>	Default: 0.00 s Min.: 0.00 Max.: 6000.0 <4>	292
L2-07 (48B)	KEB Acceleration Time	<p>All Modes</p> <p>Sets the time to accelerate to the frequency reference when momentary power loss is over. If set to 0.0, the active acceleration time is used.</p>	Default: 0.00 s Min.: 0.00 Max.: 6000.0 <4>	292
L2-08 (48C)	Frequency Gain at KEB Start	<p>V/f V/f w PG OLV CLV</p> <p>OLV/PM AOLV/PM CLV/PM</p> <p>Sets the percentage of output frequency reduction at the beginning of deceleration when the KEB Ride-Thru function is started. Reduction = (slip frequency before KEB) × L2-08 × 2</p>	Default: 100% Min.: 0 Max.: 300	292

No. (Addr. Hex)	Name	Description	Values	Page
L2-10 (48E)	KEB Detection Time (Minimum KEB Time)	All Modes Sets the time to perform KEB Ride-Thru.	Default: 50 ms Min.: 0 Max.: 2000	292
L2-11 (461)	DC Bus Voltage Setpoint during KEB	All Modes Sets the desired value of the DC bus voltage during KEB Ride-Thru.	Default: <2> [E1-01] × 1.22 Min.: 150 Vdc Max.: 400 Vdc <2>	293
L2-29 (475)	KEB Method Selection	All Modes 0: Single Drive KEB Ride-Thru 1 1: Single Drive KEB Ride-Thru 2 2: System KEB Ride-Thru 1 3: System KEB Ride-Thru 2	Default: 0 Range: 0 to 3	293

- <1> Default setting is dependent on parameters C6-01, Drive Duty Selection, and o2-04, Drive Model Selection.
- <2> Default setting is dependent on parameter E1-01, Input voltage Setting.
- <3> Values shown are specific to 200 V class drives. Double the value for 400 V class drives. Multiply the value by 2.875 for 600 V class drives.
- <4> Setting range value is dependent on parameter C1-10, Accel/Decel Time Setting Units. When C1-10 = 0 (units of 0.01 seconds), the setting range becomes 0.00 to 600.00 seconds.
- <5> Values shown are specific to 200 V class drives. Double the value for 400 V class drives. Multiply the value by 2.875 for 600 V class drives, but set the value below 1040 Vdc (overvoltage protection level).

◆ L3: Stall Prevention

No. (Addr. Hex)	Name	Description	Values	Page
L3-01 (48F)	Stall Prevention Selection during Acceleration	<input checked="" type="radio"/> V/f <input checked="" type="radio"/> V/f w PG <input checked="" type="radio"/> OLV <input type="radio"/> CLV <input checked="" type="radio"/> OLV/PM <input type="radio"/> AOLV/PM <input type="radio"/> CLV/PM 0: Disabled. 1: General purpose. Acceleration is paused as long as the current is above the L3-02 setting. 2: Intelligent. Accelerate in the shortest possible time without exceeding the L3-02 level. Note: Setting 2 is not available when using OLV/PM.	Default: 1 Range: 0 to 2	293
L3-02 (490)	Stall Prevention Level during Acceleration	<input checked="" type="radio"/> V/f <input checked="" type="radio"/> V/f w PG <input checked="" type="radio"/> OLV <input type="radio"/> CLV <input checked="" type="radio"/> OLV/PM <input type="radio"/> AOLV/PM <input type="radio"/> CLV/PM Used when L3-01 = 1 or 2. 100% is equal to the drive rated current.	Default: <1> Min.: 0% Max.: 150% <1>	294
L3-03 (491)	Stall Prevention Limit during Acceleration	<input checked="" type="radio"/> V/f <input checked="" type="radio"/> V/f w PG <input checked="" type="radio"/> OLV <input type="radio"/> CLV <input checked="" type="radio"/> OLV/PM <input type="radio"/> AOLV/PM <input type="radio"/> CLV/PM Sets Stall Prevention lower limit during acceleration when operating in the constant power range. Set as a percentage of drive rated current.	Default: 50% Min.: 0 Max.: 100	295
L3-04 (492)	Stall Prevention Selection during Deceleration	All Modes 0: Disabled. Deceleration at the active deceleration rate. An ov fault may occur. 1: General purpose. Deceleration is paused when the DC bus voltage exceeds the Stall Prevention level. 2: Intelligent. Decelerate as fast as possible while avoiding ov faults. 3: Stall Prevention with braking resistor. Stall Prevention during deceleration is enabled in coordination with dynamic braking. 4: Overexcitation Deceleration. Decelerates while increasing the motor flux. 5: Overexcitation Deceleration 2. Adjust the deceleration rate according to the DC bus voltage.	Default: 1 Range: 0 to 5 <2>	295
L3-05 (493)	Stall Prevention Selection during Run	<input checked="" type="radio"/> V/f <input checked="" type="radio"/> V/f w PG <input type="radio"/> OLV <input type="radio"/> CLV <input checked="" type="radio"/> OLV/PM <input type="radio"/> AOLV/PM <input type="radio"/> CLV/PM 0: Disabled. Drive runs at a set frequency. A heavy load may cause speed loss. 1: Decel time 1. Uses the deceleration time set to C1-02 while Stall Prevention is performed. 2: Decel time 2. Uses the deceleration time set to C1-04 while Stall Prevention is performed.	Default: 1 Range: 0 to 2	296

Parameter List

B

B.10 L: Protection Function

No. (Addr. Hex)	Name	Description	Values	Page
L3-06 (494)	Stall Prevention Level during Run	<p><input checked="" type="radio"/> V/f <input checked="" type="radio"/> V/f w PG <input type="radio"/> OLV <input type="radio"/> CLV</p> <p><input checked="" type="radio"/> OLV/PM <input type="radio"/> AOLV/PM <input type="radio"/> CLV/PM</p> <p>Enabled when L3-05 is set to 1 or 2. 100% is equal to the drive rated current.</p>	Default: <1> Min.: 30% Max.: 150% <1>	297
L3-11 (4C7)	Overvoltage Suppression Function Selection	<p><input checked="" type="radio"/> All Modes</p> <p>Enables or disables the ov suppression function, which allows the drive to change the output frequency as the load changes to prevent an ov fault. 0: Disabled 1: Enabled</p>	Default: 0 Range: 0, 1	297
L3-17 (462)	Target DC Bus Voltage for Overvoltage Suppression and Stall Prevention	<p><input checked="" type="radio"/> All Modes</p> <p>Sets the desired value for the DC bus voltage during overvoltage suppression and Stall Prevention during deceleration.</p>	Default: 375 Vdc <3> <8> Min.: 150 Max.: 400 <8>	297
L3-20 (465)	DC Bus Voltage Adjustment Gain	<p><input checked="" type="radio"/> All Modes</p> <p>Sets the proportional gain for KEB Ride-Thru, Stall Prevention, and overvoltage suppression.</p>	Default: <4> Min.: 0.00 Max.: 5.00	298
L3-21 (466)	Accel/Decel Rate Calculation Gain	<p><input checked="" type="radio"/> All Modes</p> <p>Sets the proportional gain used to calculate the deceleration rate during KEB Ride-Thru, ov suppression function, and Stall Prevention during deceleration (L3-04 = 2).</p>	Default: 1.00 Min.: 0.10 Max.: 10.00	298
L3-22 (4F9)	Deceleration Time at Stall Prevention during Acceleration	<p><input type="radio"/> V/f <input type="radio"/> V/f w PG <input type="radio"/> OLV <input type="radio"/> CLV</p> <p><input checked="" type="radio"/> OLV/PM <input type="radio"/> AOLV/PM <input type="radio"/> CLV/PM</p> <p>Sets the deceleration time used for Stall Prevention during acceleration in OLV/PM.</p>	Default: 0.0 s Min.: 0.0 Max.: 6000.0	295
L3-23 (4FD)	Automatic Reduction Selection for Stall Prevention during Run	<p><input checked="" type="radio"/> V/f <input checked="" type="radio"/> V/f w PG <input type="radio"/> OLV <input type="radio"/> CLV</p> <p><input type="radio"/> OLV/PM <input type="radio"/> AOLV/PM <input type="radio"/> CLV/PM</p> <p>0: Sets the Stall Prevention level set in L3-04 that is used throughout the entire frequency range. 1: Automatic Stall Prevention level reduction in the constant output range. The lower limit value is 40% of L3-06.</p>	Default: 0 Range: 0, 1	297
L3-24 (46E)	Motor Acceleration Time for Inertia Calculations	<p><input checked="" type="radio"/> All Modes</p> <p>Sets the time needed to accelerate the uncoupled motor at rated torque from stop to the maximum frequency.</p>	Default: <5> <6> <7> Min: 0.001 s Max: 10.000 s	298
L3-25 (46F)	Load Inertia Ratio	<p><input type="radio"/> V/f <input type="radio"/> V/f w PG <input checked="" type="radio"/> OLV <input type="radio"/> CLV</p> <p><input checked="" type="radio"/> OLV/PM <input type="radio"/> AOLV/PM <input type="radio"/> CLV/PM</p> <p>Sets the ratio between the motor and machine inertia.</p>	Default: 1.0 Min.: 1.0 Max.: 1000.0	299
L3-26 (455)	Additional DC Bus Capacitors	<p><input checked="" type="radio"/> All Modes</p> <p>When DC bus capacitors have been added externally, be sure to add those values to the internal capacitor table for proper DC bus calculations.</p>	Default: 0 μF Min: 0 Max: 65000	299
L3-27 (456)	Stall Prevention Detection Time	<p><input type="radio"/> V/f <input type="radio"/> V/f w PG <input checked="" type="radio"/> OLV <input type="radio"/> CLV</p> <p><input checked="" type="radio"/> OLV/PM <input type="radio"/> AOLV/PM <input type="radio"/> CLV/PM</p> <p>Sets the time the current must exceed the Stall Prevention level to activate Stall Prevention.</p>	Default: 50 ms Min.: 0 Max.: 5000	299
L3-34 (16F)	Torque Limit Delay Time	<p><input type="radio"/> V/f <input type="radio"/> V/f w PG <input type="radio"/> OLV <input type="radio"/> CLV</p> <p><input type="radio"/> OLV/PM <input checked="" type="radio"/> AOLV/PM <input checked="" type="radio"/> CLV/PM</p> <p>Sets the filter time constant in seconds for the torque limit value to return to set value when the Power KEB Ride-Thru is enabled (L2-29 = 1). If oscillation occurs during Power KEB Ride-Thru, then gradually increase this setting in increments of 0.010 s.</p> <p>Note: This parameter is not available in models 4A0930 and 4A1200.</p>	Default: <9> Min.: 0.000 Max.: 1.000	299

<1> Upper limit is dependent on parameters C6-01, Drive Duty Selection, and L8-38, Frequency Reduction Selection.

<2> The setting range is 0 to 2 in OLV/PM control mode. The setting range is 0 and 1 in CLV or AOLV/PM control modes.

<3> Default setting is dependent on parameter E1-01, Input voltage Setting.

<4> Default setting is determined by parameter A1-02, Control Mode Setting.

<5> Parameter value changes automatically if E2-11 is manually changed or changed by Auto-Tuning.

<6> Default setting is dependent on parameters C6-01, Drive Duty Selection, and o2-04, Drive Model Selection.

- <7> Default setting is dependent on parameter E5-01, Motor Code Selection.
- <8> Values shown are specific to 200 V class drives. Double the value for 400 V class drives. Multiply the value by 2.875 for 600 V class drives, but set the value below 1040 Vdc (overvoltage protection level).
- <9> Default setting is dependent on parameter A1-02, Control Method Selection.

◆ L4: Speed Detection

No. (Addr. Hex)	Name	Description	Values	Page
L4-01 (499)	Speed Agreement Detection Level	All Modes L4-01 sets the frequency detection level for digital output functions H2-□□ = 2, 3, 4, 5.	Default: 0.0 Hz Min.: 0.0 Max.: 400.0	300
L4-02 (49A)	Speed Agreement Detection Width	All Modes L4-02 sets the hysteresis or allowable margin for speed detection.	Default: <7> Min.: 0.0 Max.: 20.0	300
L4-03 (49B)	Speed Agreement Detection Level (+/-)	All Modes L4-03 sets the frequency detection level for digital output functions H2-□□ = 13, 14, 15, 16.	Default: 0.0 Hz Min.: -400.0 Max.: 400.0	300
L4-04 (49C)	Speed Agreement Detection Width (+/-)	All Modes L4-04 sets the hysteresis or allowable margin for speed detection.	Default: <7> Min.: 0.0 Max.: 20.0	300
L4-05 (49D)	Frequency Reference Loss Detection Selection	All Modes 0: Stop. Drive stops when the frequency reference is lost. 1: Run. Drive runs at a reduced speed when the frequency reference is lost.	Default: 0 Range: 0, 1	300
L4-06 (4C2)	Frequency Reference at Reference Loss	All Modes Sets the percentage of the frequency reference that the drive should run with when the frequency reference is lost.	Default: 80.0% Min.: 0.0 Max.: 100.0	300
L4-07 (470)	Speed Agreement Detection Selection	All Modes 0: No detection during baseblock. 1: Detection always enabled.	Default: 0 Range: 0, 1	301

- <1> Default setting is dependent on parameter A1-02, Control Method Selection.

◆ L5: Fault Restart

No. (Addr. Hex)	Name	Description	Values	Page
L5-01 (49E)	Number of Auto Restart Attempts	All Modes Sets the number of times the drive may attempt to restart after the following faults occur: GF, LF, oC, ov, PF, rH, rr, oL1, oL2, oL3, oL4, STo, Uv1.	Default: 0 Min.: 0 Max.: 10	301
L5-02 (49F)	Auto Restart Fault Output Operation Selection	All Modes 0: Fault output not active. 1: Fault output active during restart attempt.	Default: 0 Range: 0, 1	301
L5-04 (46C)	Fault Reset Interval Time	All Modes Sets the amount of time to wait between performing fault restarts.	Default: 10.0 s Min.: 0.5 Max.: 600.0	302
L5-05 (467)	Fault Reset Operation Selection	All Modes 0: Continuously attempt to restart while incrementing restart counter only at a successful restart (same as F7 and G7). 1: Attempt to restart with the interval time set in L5-04 and increment the restart counter with each attempt (same as V7).	Default: 0 Range: 0, 1	302

◆ L6: Torque Detection

No. (Addr. Hex)	Name	Description	Values	Page
L6-01 (4A1)	Torque Detection Selection 1	<p>All Modes</p> <p>0: Disabled 1: oL3 detection only active during speed agree, operation continues after detection 2: oL3 detection always active during run, operation continues after detection 3: oL3 detection only active during speed agree, output shuts down on an oL3 fault 4: oL3 detection always active during run, output shuts down on an oL3 fault 5: UL3 detection only active during speed agree, operation continues after detection 6: UL3 detection always active during run, operation continues after detection 7: UL3 detection only active during speed agree, output shuts down on an oL3 fault 8: UL3 detection always active during run, output shuts down on an oL3 fault</p>	Default: 0 Range: 0 to 8	303
L6-02 (4A2)	Torque Detection Level 1	<p>All Modes</p> <p>Sets the overtorque and undertorque detection level.</p>	Default: 150% Min.: 0 Max.: 300	303
L6-03 (4A3)	Torque Detection Time 1	<p>All Modes</p> <p>Sets the time an overtorque or undertorque condition must exist to trigger torque detection 1.</p>	Default: 0.1 s Min.: 0.0 Max.: 10.0	304
L6-04 (4A4)	Torque Detection Selection 2	<p>All Modes</p> <p>0: Disabled 1: oL4 detection only active during speed agree, operation continues after detection 2: oL4 detection always active during run, operation continues after detection 3: oL4 detection only active during speed agree, output shuts down on an oL4 fault 4: oL4 detection always active during run, output shuts down on an oL4 fault 5: UL4 detection only active during speed agree, operation continues after detection 6: UL4 detection always active during run, operation continues after detection 7: UL4 detection only active during speed agree, output shuts down on an oL4 fault 8: UL4 detection always active during run, output shuts down on an oL4 fault</p>	Default: 0 Range: 0 to 8	303
L6-05 (4A5)	Torque Detection Level 2	<p>All Modes</p> <p>Sets the overtorque and undertorque detection level.</p>	Default: 150% Min.: 0 Max.: 300	303
L6-06 (4A6)	Torque Detection Time 2	<p>All Modes</p> <p>Sets the time an overtorque or undertorque condition must exist to trigger torque detection 2.</p>	Default: 0.1 s Min.: 0.0 Max.: 10.0	304
L6-08 (468)	Mechanical Weakening Detection Operation	<p>All Modes</p> <p>This function can detect an overtorque or undertorque in a certain speed range as a result of machine fatigue. It is triggered by a specified operation time and uses the oL1 detection settings (L6-01 and L6-03). 0: Mechanical Weakening Detection disabled. 1: Continue running (alarm only). Detected when the speed (signed) is greater than L6-09. 2: Continue running (alarm only). Detected when the speed (not signed) is greater than L6-09. 3: Interrupt drive output (fault). Detected when the speed (signed) is greater than L6-09. 4: Interrupt drive output (fault). Detected when the speed (not signed) is greater than L6-09. 5: Continue running (alarm only). Detected when the speed (signed) is less than L6-09. 6: Continue running (alarm only). Detected when the speed (not signed) is less than L6-09. 7: Interrupt drive output (fault). Detected when the speed (signed) is less than L6-09. 8: Interrupt drive output (fault). Detected when the speed (not signed) is less than L6-09.</p>	Default: 0 Range: 0 to 8	304

No. (Addr. Hex)	Name	Description	Values	Page
L6-09 (469)	Mechanical Weakening Detection Speed Level	All Modes Sets the speed that triggers Mechanical Weakening Detection. When L6-08 is set for an unsigned value, the absolute value is used if the setting is negative.	Default: 110.0% Min.: -110.0 Max.: 110.0	304
L6-10 (46A)	Mechanical Weakening Detection Time	All Modes Sets the time mechanical weakening has to be detected before an alarm or fault is triggered.	Default: 0.1 s Min.: 0.0 Max.: 10.0	305
L6-11 (46B)	Mechanical Weakening Detection Start Time	All Modes Sets the operation time (U1-04) required before Mechanical Weakening Detection is active.	Default: 0 h Min.: 0 Max.: 65535	305

◆ L7: Torque Limit

No. (Addr. Hex)	Name	Description	Values	Page
L7-01 (4A7)	Forward Torque Limit	<input type="checkbox"/> V/f <input type="checkbox"/> V/f w PG <input checked="" type="checkbox"/> OLV <input type="checkbox"/> CLV <input type="checkbox"/> OLV/PM <input type="checkbox"/> AOLV/PM <input checked="" type="checkbox"/> CLV/PM	Default: 200% Min.: 0 Max.: 300	305
L7-02 (4A8)	Reverse Torque Limit	Sets the torque limit value as a percentage of the motor rated torque. Four individual quadrants can be set. 	Default: 200% Min.: 0 Max.: 300	305
L7-03 (4A9)	Forward Regenerative Torque Limit		Default: 200% Min.: 0 Max.: 300	305
L7-04 (4AA)	Reverse Regenerative Torque Limit		Default: 200% Min.: 0 Max.: 300	305
L7-06 (4AC)	Torque Limit Integral Time Constant		<input type="checkbox"/> V/f <input type="checkbox"/> V/f w PG <input checked="" type="checkbox"/> OLV <input type="checkbox"/> CLV <input type="checkbox"/> OLV/PM <input type="checkbox"/> AOLV/PM <input type="checkbox"/> CLV/PM	Default: 200 ms Min.: 5 Max.: 10000
L7-07 (4C9)	Torque Limit Control Method Selection during Accel/Decel	<input type="checkbox"/> V/f <input type="checkbox"/> V/f w PG <input checked="" type="checkbox"/> OLV <input type="checkbox"/> CLV <input type="checkbox"/> OLV/PM <input type="checkbox"/> AOLV/PM <input type="checkbox"/> CLV/PM	Default: 0 Range: 0, 1	306

◆ L8: Drive Protection

No. (Addr. Hex)	Name	Description	Values	Page
L8-01 (4AD)	Internal Dynamic Braking Resistor Protection Selection (ERF type)	All Modes 0: Resistor overheat protection disabled 1: Resistor overheat protection enabled Note: This parameter is not available in models 4A0930 and 4A1200.	Default: 0 Range: 0, 1	306
L8-02 (4AE)	Overheat Alarm Level	All Modes An overheat alarm occurs when heatsink temperature exceeds the L8-02 level.	Default: <I> Min.: 50 °C Max.: 150 °C	306
L8-03 (4AF)	Overheat Pre-Alarm Operation Selection	All Modes 0: Ramp to stop. A fault is triggered. 1: Coast to stop. A fault is triggered. 2: Fast Stop. Decelerate to stop using the deceleration time in C1-09. A fault is triggered. 3: Continue operation. An alarm is triggered. 4: Continue operation at reduced speed as set in L8-19.	Default: 3 Range: 0 to 4	307

B.10 L: Protection Function

No. (Addr. Hex)	Name	Description	Values	Page
L8-05 (4B1)	Input Phase Loss Protection Selection	All Modes Selects the detection of input current phase loss, power supply voltage imbalance, or main circuit electrolytic capacitor deterioration. 0: Disabled 1: Enabled	Default: 1 Range: 0, 1	308
L8-07 (4B3)	Output Phase Loss Protection Selection	All Modes 0: Disabled 1: Enabled (triggered by a single phase loss) 2: Enabled (triggered when two phases are lost)	Default: 1 Range: 0 to 2	308
L8-09 (4B5)	Output Ground Fault Detection Selection	All Modes 0: Disabled 1: Enabled	Default: <1> Range: 0, 1	308
L8-10 (4B6)	Heatsink Cooling Fan Operation Selection	All Modes 0: During run only. Fan operates only during run for L8-11 seconds after stop. 1: Fan always on. Cooling fan operates whenever the drive is powered up.	Default: 0 Range: 0, 1	308
L8-11 (4B7)	Heatsink Cooling Fan Off Delay Time	All Modes Sets a delay time to shut off the cooling fan after the Run command is removed when L8-10 = 0.	Default: 60 s Min.: 0 Max.: 300	309
L8-12 (4B8)	Ambient Temperature Setting	All Modes Enter the ambient temperature. This value adjusts the oL2 detection level.	Default: 40 °C Min.: -10 Max.: 50	309
L8-15 (4BB)	oL2 Characteristics Selection at Low Speeds	All Modes 0: No oL2 level reduction below 6 Hz. 1: oL2 level is reduced linearly below 6 Hz. It is halved at 0 Hz.	Default: 1 Range: 0, 1	309
L8-18 (4BE)	Software Current Limit Selection	V/f V/f w PG OLV CLV OLV/PM AOLV/PM CLV/PM 0: Disabled 1: Enabled	Default: 0 Range: 0, 1	309
L8-19 (4BF)	Frequency Reduction Rate during Overheat Pre-Alarm	All Modes Specifies the frequency reference reduction gain at overheat pre-alarm when L8-03 = 4.	Default: 0.8 Min.: 0.1 Max.: 0.9	307
L8-27 (4DD)	Overcurrent Detection Gain	V/f V/f w PG OLV CLV OLV/PM AOLV/PM CLV/PM Sets the gain for overcurrent detection as a percentage of the motor rated current. Overcurrent is detected using the lower value between the overcurrent level of the drive or the value set to L8-27.	Default: 300.0% Min.: 0.0 Max.: 400.0 <2>	309
L8-29 (4DF)	Current Unbalance Detection (LF2)	V/f V/f w PG OLV CLV OLV/PM AOLV/PM CLV/PM 0: Disabled 1: Enabled	Default: 1 Range: 0, 1	310
L8-32 (4E2)	Main Contactor and Cooling Fan Power Supply Failure Selection	All Modes Determines drive response when a fault occurs with the internal cooling fan. 0: Ramp to stop 1: Coast to stop 2: Fast stop (Decelerate to stop using the deceleration time set to C1-09) 3: Alarm only ("FAN" will flash) 4: Continue operation at reduced speed as set to L8-19.	Default: 1 Range: 0 to 4	310
L8-35 (4EC)	Installation Method Selection	All Modes 0: IP00/Open-Chassis enclosure 1: Side-by-Side mounting 2: IP20/NEMA Type 1 enclosure 3: Finless model drive or external heatsink installation	Default: <2> <3> <1> Range: 0 to 3	310
L8-38 (4EF)	Carrier Frequency Reduction	V/f V/f w PG OLV CLV OLV/PM AOLV/PM CLV/PM 0: Disabled 1: Enabled below 6 Hz 2: Enabled for the entire speed range	Default: <2> Range: 0 to 2	311

No. (Addr. Hex)	Name	Description	Values	Page
L8-40 (4F1)	Carrier Frequency Reduction Off Delay Time	<p>V/f V/f w PG OLV CLV OLV/PM AOLV/PM CLV/PM</p> <p>Sets the time that the drive continues running with reduced carrier frequency after the carrier reduction condition is gone. Setting 0.00 s disables the carrier frequency reduction time.</p>	Default: <6> Min.: 0.00 s Max.: 2.00 s	311
L8-41 (4F2)	High Current Alarm Selection	<p>All Modes</p> <p>0: Disabled 1: Enabled. An alarm is triggered at output currents above 150% of drive rated current.</p>	Default: 0 Range: 0, 1	311
L8-55 (45F)	Internal Braking Transistor Protection	<p>All Modes</p> <p>0: Disabled. Disable when using a regen converter or optional braking unit. 1: Protection enabled.</p> <p>Note: This parameter is not available in models 4A0930 and 4A1200.</p>	Default: 1 Range: 0, 1	311
L8-78 (2CC)	Power Unit Output Phase Loss Protection	<p>All Modes</p> <p>Enables motor protection in the event of output phase loss. 0: Disabled 1: Enabled</p> <p>Note: This parameter is only available in models 4A0930 and 4A1200.</p>	Default: 1 Range: 0, 1	311
L8-93 (73C)	LSO Detection Time at Low Speed	<p>V/f V/f w PG OLV CLV OLV/PM AOLV/PM CLV/PM</p> <p>Sets the amount of time until baseblock is executed after detecting pull-out at low speed.</p>	Default: 1.0 s Min.: 0.0 Max.: 10.0	312
L8-94 (73D)	LSO Detection Level at Low Speed	<p>V/f V/f w PG OLV CLV OLV/PM AOLV/PM CLV/PM</p> <p>Determines the detection level of pull-out at low speed.</p>	Default: 3% Min.: 0 Max.: 10	312
L8-95 (73D)	Average LSO Frequency at Low Speed	<p>V/f V/f w PG OLV CLV OLV/PM AOLV/PM CLV/PM</p> <p>Sets the average number of times pull-out can occur at low speed.</p>	Default: 10 times Min.: 1 Max.: 50	312

- <1> Default setting is dependent on parameters C6-01, Drive Duty Selection, and o2-04, Drive Model Selection.
- <2> The setting range is 0.0 to 300.0% for models 4A0930 and 4A1200.
- <3> Parameter setting value is not reset to the default value when the drive is initialized.
- <4> Default setting is determined by the drive model:
 Setting 2: Model code 2A0004 to 2A0211, 4A0002 to 4A0165, and 5A0003 to 5A0242
 Setting 0: Model code 2A0250 to 2A0415 and 4A0208 to 4A1200
- <5> Default setting is dependent on parameters A1-02, Control Method Selection, and o2-04, Drive Model Selection.
- <6> Default setting is dependent on parameter A1-02, Control Method Selection.

B.11 n: Special Adjustment

The n parameters adjust more advanced performance characteristics such as Hunting Prevention, speed feedback detection, High Slip Braking, and Online Tuning for motor line-to-line resistance.

◆ n1: Hunting Prevention

No. (Addr. Hex)	Name	Description	Values	Page
n1-01 (580)	Hunting Prevention Selection	<p><input checked="" type="radio"/> V/f <input checked="" type="radio"/> V/f w PG <input type="radio"/> OLV <input type="radio"/> CLV</p> <p><input type="radio"/> OLV/PM <input type="radio"/> AOLV/PM <input type="radio"/> CLV/PM</p> <p>0: Disabled 1: Enabled</p>	Default: 1 Range: 0, 1	313
n1-02 (581)	Hunting Prevention Gain Setting	<p><input checked="" type="radio"/> V/f <input checked="" type="radio"/> V/f w PG <input type="radio"/> OLV <input type="radio"/> CLV</p> <p><input type="radio"/> OLV/PM <input type="radio"/> AOLV/PM <input type="radio"/> CLV/PM</p> <p>If the motor vibrates while lightly loaded, increase the gain by 0.1 until vibration ceases. If the motor stalls, decrease the gain by 0.1 until the stalling ceases.</p>	Default: 1.00 Min.: 0.00 Max.: 2.50	313
n1-03 (582)	Hunting Prevention Time Constant	<p><input checked="" type="radio"/> V/f <input checked="" type="radio"/> V/f w PG <input type="radio"/> OLV <input type="radio"/> CLV</p> <p><input type="radio"/> OLV/PM <input type="radio"/> AOLV/PM <input type="radio"/> CLV/PM</p> <p>Sets the time constant used for Hunting Prevention.</p>	Default: <I> Min.: 0 ms Max.: 500 ms	313
n1-05 (530)	Hunting Prevention Gain while in Reverse	<p><input checked="" type="radio"/> V/f <input checked="" type="radio"/> V/f w PG <input type="radio"/> OLV <input type="radio"/> CLV</p> <p><input type="radio"/> OLV/PM <input type="radio"/> AOLV/PM <input type="radio"/> CLV/PM</p> <p>Sets the gain used for Hunting Prevention. If set to 0, the gain set to n1-02 is used for operation in reverse.</p>	Default: 0.00 Min.: 0.00 Max.: 2.50	313

<I> Default setting is dependent on parameter o2-04, Drive Model Selection.

◆ n2: Speed Feedback Detection Control (AFR) Tuning

No. (Addr. Hex)	Name	Description	Values	Page
n2-01 (584)	Speed Feedback Detection Control (AFR) Gain	<p><input type="radio"/> V/f <input type="radio"/> V/f w PG <input checked="" type="radio"/> OLV <input type="radio"/> CLV</p> <p><input type="radio"/> OLV/PM <input type="radio"/> AOLV/PM <input type="radio"/> CLV/PM</p> <p>Sets the internal speed feedback detection control gain in the automatic frequency regulator (AFR). If hunting occurs, increase the set value. If response is low, decrease the set value.</p>	Default: 1.00 Min.: 0.00 Max.: 10.00	314
n2-02 (585)	Speed Feedback Detection Control (AFR) Time Constant 1	<p><input type="radio"/> V/f <input type="radio"/> V/f w PG <input checked="" type="radio"/> OLV <input type="radio"/> CLV</p> <p><input type="radio"/> OLV/PM <input type="radio"/> AOLV/PM <input type="radio"/> CLV/PM</p> <p>Sets the time constant used for speed feedback detection control (AFR).</p>	Default: 50 ms Min.: 0 Max.: 2000	314
n2-03 (586)	Speed Feedback Detection Control (AFR) Time Constant 2	<p><input type="radio"/> V/f <input type="radio"/> V/f w PG <input checked="" type="radio"/> OLV <input type="radio"/> CLV</p> <p><input type="radio"/> OLV/PM <input type="radio"/> AOLV/PM <input type="radio"/> CLV/PM</p> <p>Sets the AFR time constant to be used during Speed Search and during regen.</p>	Default: 750 ms Min.: 0 Max.: 2000	314

◆ n3: High Slip Braking (HSB) and Overexcitation Braking

No. (Addr. Hex)	Name	Description	Values	Page
n3-01 (588)	High-Slip Braking Deceleration Frequency Width	<p><input checked="" type="radio"/> V/f <input checked="" type="radio"/> V/f w PG <input type="radio"/> OLV <input type="radio"/> CLV</p> <p><input type="radio"/> OLV/PM <input type="radio"/> AOLV/PM <input type="radio"/> CLV/PM</p> <p>Sets the output frequency reduction step width for when the drive stops the motor using HSB. Set as a percentage of the maximum output frequency. Increase this setting if overvoltage occurs during HSB.</p>	Default: 5% Min.: 1 Max.: 20	314
n3-02 (589)	High-Slip Braking Current Limit	<p><input checked="" type="radio"/> V/f <input checked="" type="radio"/> V/f w PG <input type="radio"/> OLV <input type="radio"/> CLV</p> <p><input type="radio"/> OLV/PM <input type="radio"/> AOLV/PM <input type="radio"/> CLV/PM</p> <p>Sets the current limit during HSB as a percentage of the motor rated current.</p>	Default: <I> Min.: 100% Max.: 200%	315

No. (Addr. Hex)	Name	Description	Values	Page
n3-03 (58A)	High-Slip Braking Dwell Time at Stop	<p>V/f V/f w PG <input type="checkbox"/> OLV <input type="checkbox"/> CLV</p> <p><input type="checkbox"/> OLV/PM <input type="checkbox"/> AOLV/PM <input type="checkbox"/> CLV/PM</p> <p>Sets the time the drive will run with minimum frequency (E1-09) at the end of deceleration. If this time is set too low, the machine inertia can cause the motor to rotate slightly after HSB.</p>	Default: 1.0 s Min.: 0.0 Max.: 10.0	315
n3-04 (58B)	High-Slip Braking Overload Time	<p>V/f V/f w PG <input type="checkbox"/> OLV <input type="checkbox"/> CLV</p> <p><input type="checkbox"/> OLV/PM <input type="checkbox"/> AOLV/PM <input type="checkbox"/> CLV/PM</p> <p>Sets the time required for an HSB overload fault (oL7) to occur when the drive output frequency does not change during an HSB stop. This parameter does not typically require adjustment.</p>	Default: 40 s Min.: 30 Max.: 1200	315
n3-13 (531)	Overexcitation Deceleration Gain	<p>V/f V/f w PG OLV CLV</p> <p><input type="checkbox"/> OLV/PM <input type="checkbox"/> AOLV/PM <input type="checkbox"/> CLV/PM</p> <p>Sets the gain applied to the V/f pattern during Overexcitation Deceleration (L3-04 = 4).</p>	Default: 1.10 Min.: 1.00 Max.: 1.40	316
n3-14 (532)	High Frequency Injection during Overexcitation Deceleration	<p>V/f V/f w PG OLV <input type="checkbox"/> CLV</p> <p><input type="checkbox"/> OLV/PM <input type="checkbox"/> AOLV/PM <input type="checkbox"/> CLV/PM</p> <p>0: Disabled 1: Enabled</p>	Default: 0 Range: 0, 1	316
n3-21 (579)	High-Slip Suppression Current Level	<p>V/f V/f w PG OLV CLV</p> <p><input type="checkbox"/> OLV/PM <input type="checkbox"/> AOLV/PM <input type="checkbox"/> CLV/PM</p> <p>Sets output current level at which the drive will start reducing the overexcitation gain in order to prevent a too high motor slip during Overexcitation Deceleration. Set as a percentage of the drive rated current.</p>	Default: 100% Min.: 0 Max.: 150	316
n3-23 (57B)	Overexcitation Operation Selection	<p>V/f V/f w PG OLV CLV</p> <p><input type="checkbox"/> OLV/PM <input type="checkbox"/> AOLV/PM <input type="checkbox"/> CLV/PM</p> <p>0: Enabled in both directions 1: Enabled only when rotating forward 2: Enabled only when in reverse</p>	Default: 0 Range: 0 to 2	316

<1> Default setting is dependent on parameters C6-01, Drive Duty Selection, and L8-38, Frequency Reduction Selection.

◆ n5: Feed Forward Control

No. (Addr. Hex)	Name	Description	Values	Page
n5-01 (5B0)	Feed Forward Control Selection	<p><input type="checkbox"/> V/f <input type="checkbox"/> V/f w PG <input type="checkbox"/> OLV CLV</p> <p><input type="checkbox"/> OLV/PM AOLV/PM CLV/PM</p> <p>0: Disabled 1: Enabled</p>	Default: 0 Range: 0, 1	317
n5-02 (5B1)	Motor Acceleration Time	<p><input type="checkbox"/> V/f <input type="checkbox"/> V/f w PG <input type="checkbox"/> OLV CLV</p> <p><input type="checkbox"/> OLV/PM AOLV/PM CLV/PM</p> <p>Sets the time required to accelerate the motor at the rated torque from stop to rated speed.</p>	Default: <1> <2> Min.: 0.001 s Max.: 10.000 s	317
n5-03 (5B2)	Feed Forward Control Gain	<p><input type="checkbox"/> V/f <input type="checkbox"/> V/f w PG <input type="checkbox"/> OLV CLV</p> <p><input type="checkbox"/> OLV/PM AOLV/PM CLV/PM</p> <p>Sets the ratio between motor and load inertia. Lower this setting if overshoot occurs at the end of acceleration.</p>	Default: 1.00 Min.: 0.00 Max.: 100.00	318

<1> Default setting is dependent on parameter E5-01, Motor Code Selection.

<2> Default setting is dependent on parameters C6-01, Drive Duty Selection, and o2-04, Drive Model Selection.

◆ n6: Online Tuning

No. (Addr. Hex)	Name	Description	Values	Page
n6-01 (570)	Online Tuning Selection	<p> <input type="radio"/> V/f <input type="radio"/> V/f w PG <input checked="" type="radio"/> OLV <input type="radio"/> CLV <input type="radio"/> OLV/PM <input type="radio"/> AOLV/PM <input type="radio"/> CLV/PM </p> <p>0: Disabled 1: Line-to-line resistance tuning 2: Voltage correction. Setting not possible when Energy Saving is enabled (b8-01).</p>	Default: 0 Range: 0 to 2	319
n6-05 (5C7)	Online Tuning Gain	<p> <input type="radio"/> V/f <input type="radio"/> V/f w PG <input checked="" type="radio"/> OLV <input type="radio"/> CLV <input type="radio"/> OLV/PM <input type="radio"/> AOLV/PM <input type="radio"/> CLV/PM </p> <p>Decrease this setting for motors with a relatively large rotor time constant. If overload occurs, increase this setting slowly in increments of 0.10.</p>	Default: 1.0 Min.: 0.1 Max.: 50.0	319

◆ n8: PM Motor Control Tuning

No. (Addr. Hex)	Name	Description	Values	Page
n8-01 (540)	Initial Rotor Position Estimation Current	<p> <input type="radio"/> V/f <input type="radio"/> V/f w PG <input type="radio"/> OLV <input type="radio"/> CLV <input type="radio"/> OLV/PM <input checked="" type="radio"/> AOLV/PM <input checked="" type="radio"/> CLV/PM </p> <p>Sets the current used for initial rotor position estimation as a percentage of the motor rated current (E5-03). If the motor nameplate lists an “Si” value, that value should be entered here.</p>	Default: 50% Min.: 0 Max.: 100	319
n8-02 (541)	Pole Attraction Current	<p> <input type="radio"/> V/f <input type="radio"/> V/f w PG <input type="radio"/> OLV <input type="radio"/> CLV <input type="radio"/> OLV/PM <input checked="" type="radio"/> AOLV/PM <input type="radio"/> CLV/PM </p> <p>Sets the current during initial polar attraction as a percentage of the motor rated current. Enter a high value when attempting to increase starting torque.</p>	Default: 80% Min.: 0 Max.: 150	319
n8-35 (562)	Initial Rotor Position Detection Selection	<p> <input type="radio"/> V/f <input type="radio"/> V/f w PG <input type="radio"/> OLV <input type="radio"/> CLV <input type="radio"/> OLV/PM <input checked="" type="radio"/> AOLV/PM <input checked="" type="radio"/> CLV/PM </p> <p>0: Pull-in 1: High frequency injection 2: Pulse injection</p>	Default: 1 Range: 0 to 2	319
n8-45 (538)	Speed Feedback Detection Control Gain	<p> <input type="radio"/> V/f <input type="radio"/> V/f w PG <input type="radio"/> OLV <input type="radio"/> CLV <input checked="" type="radio"/> OLV/PM <input type="radio"/> AOLV/PM <input type="radio"/> CLV/PM </p> <p>Increase this setting if hunting occurs. Decrease to lower the response.</p>	Default: 0.80 Min.: 0.00 Max.: 10.00	320
n8-47 (53A)	Pull-In Current Compensation Time Constant	<p> <input type="radio"/> V/f <input type="radio"/> V/f w PG <input type="radio"/> OLV <input type="radio"/> CLV <input checked="" type="radio"/> OLV/PM <input type="radio"/> AOLV/PM <input type="radio"/> CLV/PM </p> <p>Sets the time constant to make the pull-in current reference and actual current value agree. Decrease the value if the motor begins to oscillate, and increase the value if it takes too long for the current reference to equal the output current.</p>	Default: 5.0 s Min.: 0.0 Max.: 100.0	320
n8-48 (53B)	Pull-In Current	<p> <input type="radio"/> V/f <input type="radio"/> V/f w PG <input type="radio"/> OLV <input type="radio"/> CLV <input checked="" type="radio"/> OLV/PM <input type="radio"/> AOLV/PM <input type="radio"/> CLV/PM </p> <p>Defines the d-Axis current reference during no-load operation at a constant speed. Set as a percentage of the motor rated current. Increase this setting if hunting occurs while running at constant speed.</p>	Default: 30% Min.: 20 Max.: 200	320
n8-49 (53C)	d-Axis Current for High Efficiency Control	<p> <input type="radio"/> V/f <input type="radio"/> V/f w PG <input type="radio"/> OLV <input type="radio"/> CLV <input checked="" type="radio"/> OLV/PM <input type="radio"/> AOLV/PM <input type="radio"/> CLV/PM </p> <p>Sets the d-Axis current reference when running a high load at constant speed. Set as a percentage of the motor rated current.</p>	Default: <-I> Min.: -200.0% Max.: 0.0%	320
n8-51 (53E)	Acceleration/Deceleration Pull-In Current	<p> <input type="radio"/> V/f <input type="radio"/> V/f w PG <input type="radio"/> OLV <input type="radio"/> CLV <input checked="" type="radio"/> OLV/PM <input type="radio"/> AOLV/PM <input type="radio"/> CLV/PM </p> <p>Sets the d-Axis current reference during acceleration/deceleration as a percentage of the motor rated current. Set to a high value when more starting torque is needed.</p>	Default: 50% Min.: 0 Max.: 200	321

No. (Addr. Hex)	Name	Description	Values	Page
n8-54 (56D)	Voltage Error Compensation Time Constant	<p>V/f V/f w PG OLV CLV</p> <p>OLV/PM AOLV/PM CLV/PM</p> <p>Adjusts the value when hunting occurs at low speed. If hunting occurs with sudden load changes, increase n8-54 in increments of 0.1. Reduce this setting if oscillation occurs at start.</p>	Default: 1.00 s Min.: 0.00 Max.: 10.00	321
n8-55 (56E)	Load Inertia	<p>V/f V/f w PG OLV CLV</p> <p>OLV/PM AOLV/PM CLV/PM</p> <p>Sets the ratio between motor and machine inertia. 0: Below 1:10 1: Between 1:10 and 1:30 2: Between 1:30 and 1:50 3: Beyond 1:50</p>	Default: 0 Min.: 0 Max.: 3	321
n8-57 (574)	High Frequency Injection	<p>V/f V/f w PG OLV CLV</p> <p>OLV/PM AOLV/PM CLV/PM</p> <p>0: Disabled. Disable when using an SPM motor. 1: Enabled. Use this setting to enhance the speed control range when using an IPM motor.</p>	Default: 0 Range: 0, 1	321
n8-62 (57D)	Output Voltage Limit	<p>V/f V/f w PG OLV CLV</p> <p>OLV/PM AOLV/PM CLV/PM</p> <p>Prevents output voltage saturation. Should be set just below the voltage provided by the input power supply.</p>	Default: 200.0 V <2> Min.: 0.0 Max.: 230.0 <2>	322
n8-65 (65C)	Speed Feedback Detection Control Gain during ov Suppression	<p>V/f V/f w PG OLV CLV</p> <p>OLV/PM AOLV/PM CLV/PM</p> <p>Sets the gain used for internal speed feedback detection during ov suppression.</p>	Default: 1.50 Min.: 0.00 Max.: 10.00	322
n8-69 (65D)	Speed Calculation Gain	<p>V/f V/f w PG OLV CLV</p> <p>OLV/PM AOLV/PM CLV/PM</p> <p>Sets the proportional gain for PLL control of an extended observer. There is normally no need to change this parameter from the default value. Note: This parameter is not available in models 4A0930 and 4A1200.</p>	Default: 1.00 Min.: 0.00 Max.: 20.00	322
n8-84 (2D3)	Polarity Judge Current	<p>V/f V/f w PG OLV CLV</p> <p>OLV/PM AOLV/PM CLV/PM</p> <p>Sets the current to determine polarity for the initial polarity calculation as a percentage of the motor rated current. 100% = Motor rated current</p>	Default: 100% Min.: 0 Max.: 150	322

<1> Default setting is dependent on parameter E5-01, Motor Code Selection.

<2> Values shown are specific to 200 V class drives. Double the value for 400 V class drives. Multiply the value by 2.875 for 600 V class drives.

B.12 o: Operator-Related Settings

The o parameters set up the digital operator displays.

◆ o1: Digital Operator Display Selection

No. (Addr. Hex)	Name	Description	Values	Page
o1-01 (500) 	Drive Mode Unit Monitor Selection	All Modes Selects the content of the last monitor that is shown when scrolling through Drive Mode display. Enter the last three digits of the monitor parameter number to be displayed: U□-□□.	Default: 106 (Monitor U1-06) Range: 104 to 809	324
o1-02 (501) 	User Monitor Selection after Power Up	All Modes 1: Frequency reference (U1-01) 2: Direction 3: Output frequency (U1-02) 4: Output current (U1-03) 5: User-selected monitor (set by o1-01)	Default: 1 Range: 1 to 5	324
o1-03 (502)	Digital Operator Display Selection	All Modes Sets the units the drive should use to display the frequency reference and motor speed monitors. 0: 0.01 Hz 1: 0.01% (100% = E1-04) 2: r/min (calculated using the number of motor poles setting in E2-04, E4-04, or E5-04) 3: User-selected units (set by o1-10 and o1-11)	Default: <1> Range: 0 to 3	324
o1-04 (503)	V/f Pattern Display Unit	 0: Hz 1: r/min	Default: <1> Range: 0, 1	325
o1-10 (520)	User-Set Display Units Maximum Value	All Modes These settings define the display values when o1-03 is set to 3.	Default: <2> Range: 1 to 60000	325
o1-11 (521)	User-Set Display Units Decimal Display	o1-10 sets the display value that is equal to the maximum output frequency. o1-11 sets the position of the decimal position.	Default: <2> Range: 0 to 3	325

<1> Default setting is dependent on parameter A1-02, Control Method Selection.

<2> Default setting is dependent on parameter o1-03, Digital Operator Display Selection.

◆ o2: Digital Operator Keypad Functions

No. (Addr. Hex)	Name	Description	Values	Page
o2-01 (505)	LO/RE Key Function Selection	All Modes 0: Disabled 1: Enabled. LO/RE key switches between LOCAL and REMOTE operation.	Default: 1 Range: 0, 1	325
o2-02 (506)	STOP Key Function Selection	All Modes 0: Disabled. STOP key is disabled in REMOTE operation. 1: Enabled. STOP key is always enabled.	Default: 1 Range: 0, 1	326
o2-03 (507)	User Parameter Default Value	All Modes 0: No change. 1: Set defaults. Saves parameter settings as default values for a User Initialization. 2: Clear all. Clears the default settings that have been saved for a User Initialization.	Default: 0 Range: 0 to 2	326
o2-04 (508)	Drive Model Selection	All Modes Enter the drive model. Setting required only if installing a new control board.	Default: Determined by drive capacity	326

No. (Addr. Hex)	Name	Description	Values	Page
o2-05 (509)	Frequency Reference Setting Method Selection	All Modes 0: ENTER key must be pressed to enter a frequency reference. 1: ENTER key is not required. The frequency reference can be adjusted using the up and down arrow keys only.	Default: 0 Range: 0, 1	326
o2-06 (50A)	Operation Selection when Digital Operator is Disconnected	All Modes 0: The drive continues operating if the digital operator is disconnected. 1: An oPr fault is triggered and the motor coasts to stop.	Default: 1 Range: 0, 1	327
o2-07 (527)	Motor Direction at Power Up when Using Operator	All Modes 0: Forward 1: Reverse This parameter requires assigning drive operation to the digital operator.	Default: 0 Range: 0, 1	327
o2-09 (50D)	–	Factory use.	–	–

◆ o3: Copy Function

No. (Addr. Hex)	Name	Description	Values	Page
o3-01 (515)	Copy Function Selection	All Modes 0: No action 1: Read parameters from the drive, saving them onto the digital operator. 2: Copy parameters from the digital operator, writing them to the drive. 3: Verify parameter settings on the drive to check if they match the data saved on the operator.	Default: 0 Range: 0 to 3	327
o3-02 (516)	Copy Allowed Selection	All Modes 0: Read operation prohibited 1: Read operation allowed	Default: 0 Range: 0, 1	328

◆ o4: Maintenance Monitor Settings

No. (Addr. Hex)	Name	Description	Values	Page
o4-01 (50B)	Cumulative Operation Time Setting	All Modes Sets the value for the cumulative operation time of the drive in units of 10 h.	Default: 0 Min.: 0 Max.: 9999	328
o4-02 (50C)	Cumulative Operation Time Selection	All Modes 0: Logs power-on time 1: Logs operation time when the drive output is active (output operation time).	Default: 0 Range: 0, 1	328
o4-03 (50E)	Cooling Fan Operation Time Setting	All Modes Sets the value of the fan operation time monitor U4-03 in units of 10 h.	Default: 0 Min.: 0 Max.: 9999	328
o4-05 (51D)	Capacitor Maintenance Setting	All Modes Sets the value of the Maintenance Monitor for the capacitors. See U4-05 to check when the capacitors may need to be replaced.	Default: 0% Min.: 0 Max.: 150	328
o4-07 (523)	DC Bus Pre-Charge Relay Maintenance Setting	All Modes Sets the value of the Maintenance Monitor for the soft charge bypass relay. See U4-06 to check when the bypass relay may need to be replaced.	Default: 0% Min.: 0 Max.: 150	329
o4-09 (525)	IGBT Maintenance Setting	All Modes Sets the value of the Maintenance Monitor for the IGBTs. See U4-07 for IGBT replacement times.	Default: 0% Min.: 0 Max.: 150	329
o4-11 (510)	U2, U3 Initialization	All Modes 0: U2-□□ and U3-□□ monitor data is not reset when the drive is initialized (A1-03). 1: U2-□□ and U3-□□ monitor data is reset when the drive is initialized (A1-03).	Default: 0 Range: 0, 1	329

B.12 o: Operator-Related Settings

No. (Addr. Hex)	Name	Description	Values	Page
o4-12 (512)	kWh Monitor Initialization	<p>All Modes</p> <p>0: U4-10 and U4-11 monitor data is not reset when the drive is initialized (A1-03). 1: U4-10 and U4-11 monitor data is reset when the drive is initialized (A1-03).</p>	Default: 0 Range: 0, 1	329
o4-13 (528)	Number of Run Commands Counter Initialization	<p>All Modes</p> <p>0: Number of Run commands counter is not reset when the drive is initialized (A1-03). 1: Number of Run commands counter is reset when the drive is initialized (A1-03).</p>	Default: 0 Range: 0, 1	329

B.13 DriveWorksEZ Parameters

◆ q: DriveWorksEZ Parameters

No. (Addr. Hex)	Name	Description	Values	Page
q1-01 to q6-07 (1600 to 1746)	DriveWorksEZ Parameters	All Modes Reserved for DriveWorksEZ	Refer to Help in the DWEZ software.	330

◆ r: DriveWorksEZ Connection Parameters

No. (Addr. Hex)	Name	Description	Values	Page
r1-01 to r1-40 (1840 to 1867)	DriveWorksEZ Connection Parameters 1 to 20 (upper/lower)	All Modes DriveWorksEZ Connection Parameters 1 to 20 (upper/lower)	Default: 0 Min.: 0 Max.: FFFF	330

B.14 T: Motor Tuning

Enter data into the following parameters to tune the motor and drive for optimal performance.

◆ T1: Induction Motor Auto-Tuning

No. (Addr. Hex)	Name	Description	Values	Page
T1-00 (700)	Motor 1/Motor 2 Selection	<p><input checked="" type="radio"/> V/f <input checked="" type="radio"/> V/f w PG <input checked="" type="radio"/> OLV <input checked="" type="radio"/> CLV</p> <p><input type="radio"/> OLV/PM <input type="radio"/> AOLV/PM <input type="radio"/> CLV/PM</p> <p>1: Motor 1 (sets E1-□□, E2-□□) 2: Motor 2 (sets E3-□□, E4-□□)</p>	Default: 1 Range: 1, 2	141
T1-01 (701) <I>	Auto-Tuning Mode Selection	<p><input checked="" type="radio"/> V/f <input checked="" type="radio"/> V/f w PG <input checked="" type="radio"/> OLV <input checked="" type="radio"/> CLV</p> <p><input type="radio"/> OLV/PM <input type="radio"/> AOLV/PM <input type="radio"/> CLV/PM</p> <p>0: Rotational Auto-Tuning 1: Stationary Auto-Tuning 1 2: Stationary Auto-Tuning for Line-to-Line Resistance 3: Rotational Auto-Tuning for V/f Control (necessary for Energy Savings and Speed Estimation Speed Search) 4: Stationary Auto-Tuning 2 8: Inertia Tuning (perform Rotational Auto-Tuning prior to Inertia Tuning) 9: ASR Gain Tuning (perform Rotational Auto-Tuning prior to ASR Gain Auto-Tuning)</p>	Default: 0 Range: 0 to 4; 8, 9 <I>	142
T1-02 (702)	Motor Rated Power	<p><input checked="" type="radio"/> V/f <input checked="" type="radio"/> V/f w PG <input checked="" type="radio"/> OLV <input checked="" type="radio"/> CLV</p> <p><input type="radio"/> OLV/PM <input type="radio"/> AOLV/PM <input type="radio"/> CLV/PM</p> <p>Sets the motor rated power as specified on the motor nameplate.</p> <p>Note: Use the following formula to convert horsepower into kilowatts: 1HP = 0.746 kW.</p>	Default: <I> Min.: 0.00 kW Max.: 650.00 kW	142
T1-03 (703)	Motor Rated Voltage	<p><input checked="" type="radio"/> V/f <input checked="" type="radio"/> V/f w PG <input checked="" type="radio"/> OLV <input checked="" type="radio"/> CLV</p> <p><input type="radio"/> OLV/PM <input type="radio"/> AOLV/PM <input type="radio"/> CLV/PM</p> <p>Sets the motor rated voltage as specified on the motor nameplate.</p>	Default: 200.0 V <I> Min: 0.0 Max: 255.0 <I>	142
T1-04 (704)	Motor Rated Current	<p><input checked="" type="radio"/> V/f <input checked="" type="radio"/> V/f w PG <input checked="" type="radio"/> OLV <input checked="" type="radio"/> CLV</p> <p><input type="radio"/> OLV/PM <input type="radio"/> AOLV/PM <input type="radio"/> CLV/PM</p> <p>Sets the motor rated current as specified on the motor nameplate.</p>	Default: <I> Min.: 10% of drive rated current Max.: 200% of drive rated current	142
T1-05 (705)	Motor Base Frequency	<p><input checked="" type="radio"/> V/f <input checked="" type="radio"/> V/f w PG <input checked="" type="radio"/> OLV <input checked="" type="radio"/> CLV</p> <p><input type="radio"/> OLV/PM <input type="radio"/> AOLV/PM <input type="radio"/> CLV/PM</p> <p>Sets the rated frequency of the motor as specified on the motor nameplate.</p>	Default: 60.0 Hz Min.: 0.0 Max.: 400.0	142
T1-06 (706)	Number of Motor Poles	<p><input checked="" type="radio"/> V/f <input checked="" type="radio"/> V/f w PG <input checked="" type="radio"/> OLV <input checked="" type="radio"/> CLV</p> <p><input type="radio"/> OLV/PM <input type="radio"/> AOLV/PM <input type="radio"/> CLV/PM</p> <p>Sets the number of motor poles as specified on the motor nameplate.</p>	Default: 4 Min.: 2 Max.: 48	142
T1-07 (707)	Motor Base Speed	<p><input checked="" type="radio"/> V/f <input checked="" type="radio"/> V/f w PG <input checked="" type="radio"/> OLV <input checked="" type="radio"/> CLV</p> <p><input type="radio"/> OLV/PM <input type="radio"/> AOLV/PM <input type="radio"/> CLV/PM</p> <p>Sets the rated speed of the motor as specified on the motor nameplate.</p>	Default: 1750 r/min Min.: 0 Max.: 24000	142
T1-08 (708)	PG Number of Pulses Per Revolution	<p><input type="radio"/> V/f <input type="radio"/> V/f w PG <input type="radio"/> OLV <input checked="" type="radio"/> CLV</p> <p><input type="radio"/> OLV/PM <input type="radio"/> AOLV/PM <input type="radio"/> CLV/PM</p> <p>Sets the number of pulses per revolution for the PG being used (pulse generator or encoder).</p>	Default: 1024 ppr Min.: 1 Max.: 60000	142
T1-09 (709)	Motor No-Load Current (Stationary Auto-Tuning)	<p><input type="radio"/> V/f <input type="radio"/> V/f w PG <input checked="" type="radio"/> OLV <input checked="" type="radio"/> CLV</p> <p><input type="radio"/> OLV/PM <input type="radio"/> AOLV/PM <input type="radio"/> CLV/PM</p> <p>Sets the no-load current for the motor. After setting the motor capacity to T1-02 and the motor rated current to T1-04, this parameter will automatically display the no-load current for a standard 4-pole Yaskawa motor. Enter the no-load current as indicated on the motor test report.</p>	Default: – Min.: 0 A Max.: T1-04	143

No. (Addr. Hex)	Name	Description	Values	Page
T1-10 (70A)	Motor Rated Slip (Stationary Auto-Tuning)	<div style="display: flex; justify-content: space-between; align-items: center;"> V/f V/f w PG OLV CLV </div> <div style="display: flex; justify-content: space-between; align-items: center;"> OLV/PM AOLV/PM CLV/PM </div> <p>Sets the motor rated slip. After setting the motor capacity to T1-02, this parameter will automatically display the motor slip for a standard 4-pole Yaskawa motor. Enter the motor slip as indicated on the motor test report.</p>	Default: – Min.: 0.00 Hz Max.: 20.00 Hz	143
T1-11 (70B)	Motor Iron Loss	<div style="display: flex; justify-content: space-between; align-items: center;"> V/f V/f w PG OLV CLV </div> <div style="display: flex; justify-content: space-between; align-items: center;"> OLV/PM AOLV/PM CLV/PM </div> <p>Sets the iron loss for determining the Energy Saving coefficient. The value is set to E2-10 (motor iron loss) set when the power is cycled. If T1-02 is changed, a default value appropriate for the motor capacity that was entered will appear.</p>	Default: 14 W <5> Min.: 0 Max.: 65535	143

- <1> The availability of certain Auto-Tuning methods depends on the control mode selected for the drive.
- <2> Default setting is determined by parameter A1-02, Control Method Setting.
- <3> Default setting is dependent on parameter o2-04, Drive Model Selection.
- <4> Values shown are specific to 200 V class drives. Double the value for 400 V class drives. Multiply the value by 2.875 for 600 V class drives.
- <5> Default setting value differs depending on the motor code value and motor parameter settings.

◆ T2: PM Motor Auto-Tuning

No. (Addr. Hex)	Name	Description	Values	Page
T2-01 (750)	PM Motor Auto-Tuning Mode Selection	<div style="display: flex; justify-content: space-between; align-items: center;"> V/f V/f w PG OLV CLV </div> <div style="display: flex; justify-content: space-between; align-items: center;"> OLV/PM AOLV/PM CLV/PM </div> <p>0: PM Motor Parameter Settings 1: PM Stationary Auto-Tuning 2: PM Stationary Auto-Tuning for Stator Resistance 3: Z Pulse Offset Tuning 8: Inertia Tuning 9: ASR Gain Auto-Tuning 11: Back EMF Constant Tuning <1></p> <ul style="list-style-type: none"> Perform Auto-Tuning for motor data (T2-01 = 0, 1, or 2) Set the motor code to E5-01. Verify all motor data entered to the drive with the motor nameplate or the motor test report. 	Default: 0 Range: 0 to 3; 8, 9, 11 <2>	143
T2-02 (751)	PM Motor Code Selection	<div style="display: flex; justify-content: space-between; align-items: center;"> V/f V/f w PG OLV CLV </div> <div style="display: flex; justify-content: space-between; align-items: center;"> OLV/PM AOLV/PM CLV/PM </div> <p>Enter the motor code when using a Yaskawa PM motor. After entering the motor code, the drive automatically sets parameters T2-03 through T2-14. When using a motor without a supported motor code or a non-Yaskawa motor, set FFFF and adjust the other T2 parameters according to the motor nameplate or the motor test report.</p>	Default: <3> Min: 0000 Max: FFFF	144
T2-03 (752)	PM Motor Type	<div style="display: flex; justify-content: space-between; align-items: center;"> V/f V/f w PG OLV CLV </div> <div style="display: flex; justify-content: space-between; align-items: center;"> OLV/PM AOLV/PM CLV/PM </div> <p>0: IPM motor 1: SPM motor. Parameter T2-17 will not be displayed with this setting.</p>	Default: 1 Range: 0, 1	144
T2-04 (730)	PM Motor Rated Power	<div style="display: flex; justify-content: space-between; align-items: center;"> V/f V/f w PG OLV CLV </div> <div style="display: flex; justify-content: space-between; align-items: center;"> OLV/PM AOLV/PM CLV/PM </div> <p>Sets the motor rated power.</p> <p>Note: Use the following formula to convert horsepower into kilowatts: 1HP = 0.746 kW.</p>	Default: <4> Min.: 0.00 kW Max.: 650.00 kW	144
T2-05 (732)	PM Motor Rated Voltage	<div style="display: flex; justify-content: space-between; align-items: center;"> V/f V/f w PG OLV CLV </div> <div style="display: flex; justify-content: space-between; align-items: center;"> OLV/PM AOLV/PM CLV/PM </div> <p>Enter the motor rated voltage as indicated on the motor nameplate.</p>	Default: 200.0 V <5> Min.: 0.0 Max.: 255.0 <5>	144

B.14 T: Motor Tuning

No. (Addr. Hex)	Name	Description	Values	Page
T2-06 (733)	PM Motor Rated Current	<input type="button" value="V/f"/> <input type="button" value="V/f w PG"/> <input type="button" value="OLV"/> <input type="button" value="CLV"/> <input type="button" value="OLV/PM"/> <input type="button" value="AOLV/PM"/> <input type="button" value="CLV/PM"/> <p>Enter the motor rated current as indicated on the motor nameplate.</p>	Default: <4> Min.: 10% of drive rated current Max.: 200% of drive rated current	144
T2-07 (753)	PM Motor Base Frequency	<input type="button" value="V/f"/> <input type="button" value="V/f w PG"/> <input type="button" value="OLV"/> <input type="button" value="CLV"/> <input type="button" value="OLV/PM"/> <input type="button" value="AOLV/PM"/> <input type="button" value="CLV/PM"/> <p>Enter the motor base frequency as indicated on the motor nameplate.</p>	Default: 87.5 Hz Min.: 0.0 Max.: 400.0	145
T2-08 (734)	Number of PM Motor Poles	<input type="button" value="V/f"/> <input type="button" value="V/f w PG"/> <input type="button" value="OLV"/> <input type="button" value="CLV"/> <input type="button" value="OLV/PM"/> <input type="button" value="AOLV/PM"/> <input type="button" value="CLV/PM"/> <p>Enter the number of motor poles for the PM motor as indicated on the motor nameplate.</p>	Default: 6 Min.: 2 Max.: 48	145
T2-09 (731)	PM Motor Base Speed	<input type="button" value="V/f"/> <input type="button" value="V/f w PG"/> <input type="button" value="OLV"/> <input type="button" value="CLV"/> <input type="button" value="OLV/PM"/> <input type="button" value="AOLV/PM"/> <input type="button" value="CLV/PM"/> <p>Enter the base speed for the PM motor as indicated on the motor nameplate.</p>	Default: 1750 r/min Min.: 0 Max.: 24000	145
T2-10 (754)	PM Motor Stator Resistance	<input type="button" value="V/f"/> <input type="button" value="V/f w PG"/> <input type="button" value="OLV"/> <input type="button" value="CLV"/> <input type="button" value="OLV/PM"/> <input type="button" value="AOLV/PM"/> <input type="button" value="CLV/PM"/> <p>Enter the rotor resistance for the PM motor as indicated on the motor nameplate.</p>	Default: <6> Min.: 0.000 Ω Max.: 65.000 Ω	145
T2-11 (735)	PM Motor d-Axis Inductance	<input type="button" value="V/f"/> <input type="button" value="V/f w PG"/> <input type="button" value="OLV"/> <input type="button" value="CLV"/> <input type="button" value="OLV/PM"/> <input type="button" value="AOLV/PM"/> <input type="button" value="CLV/PM"/> <p>Enter the d-axis inductance for the PM motor as indicated on the motor nameplate.</p>	Default: <6> Min.: 0.00 mH Max.: 600.00 mH	145
T2-12 (736)	PM Motor q-Axis Inductance	<input type="button" value="V/f"/> <input type="button" value="V/f w PG"/> <input type="button" value="OLV"/> <input type="button" value="CLV"/> <input type="button" value="OLV/PM"/> <input type="button" value="AOLV/PM"/> <input type="button" value="CLV/PM"/> <p>Enter the q-axis inductance for the PM motor as indicated on the motor nameplate.</p>	Default: <6> Min.: 0.00 mH Max.: 600.00 mH	145
T2-13 (755)	Induced Voltage Constant Unit Selection	<input type="button" value="V/f"/> <input type="button" value="V/f w PG"/> <input type="button" value="OLV"/> <input type="button" value="CLV"/> <input type="button" value="OLV/PM"/> <input type="button" value="AOLV/PM"/> <input type="button" value="CLV/PM"/> <p>0: mV/(r/min). E5-09 will automatically be set to 0.0, and E5-24 will be used. 1: mV/(rad/sec). E5-24 will automatically be set to 0.0, and E5-09 will be used.</p>	Default: 1 Range: 0, 1	145
T2-14 (737)	PM Motor Induced Voltage Constant	<input type="button" value="V/f"/> <input type="button" value="V/f w PG"/> <input type="button" value="OLV"/> <input type="button" value="CLV"/> <input type="button" value="OLV/PM"/> <input type="button" value="AOLV/PM"/> <input type="button" value="CLV/PM"/> <p>Enter the induced voltage coefficient for the PM motor as indicated on the motor nameplate.</p>	Default: <6> Min.: 0.1 Max.: 2000.0	145
T2-15 (756)	Pull-In Current Level for PM Motor Tuning	<input type="button" value="V/f"/> <input type="button" value="V/f w PG"/> <input type="button" value="OLV"/> <input type="button" value="CLV"/> <input type="button" value="OLV/PM"/> <input type="button" value="AOLV/PM"/> <input type="button" value="CLV/PM"/> <p>Sets the amount of pull-in current to use for Auto-Tuning as a percentage of the motor rated current. Increase this setting for high inertia loads.</p>	Default: 30% Min.: 0 Max.: 120	146
T2-16 (738)	PG Number of Pulses Per Revolution for PM Motor Tuning	<input type="button" value="V/f"/> <input type="button" value="V/f w PG"/> <input type="button" value="OLV"/> <input type="button" value="CLV"/> <input type="button" value="OLV/PM"/> <input type="button" value="AOLV/PM"/> <input type="button" value="CLV/PM"/> <p>Sets the number of pulses per revolution for the PG being used (pulse generator or encoder).</p>	Default: 1024 ppr Min.: 1 Max.: 15000	146
T2-17 (757)	Encoder Z-Pulse Offset	<input type="button" value="V/f"/> <input type="button" value="V/f w PG"/> <input type="button" value="OLV"/> <input type="button" value="CLV"/> <input type="button" value="OLV/PM"/> <input type="button" value="AOLV/PM"/> <input type="button" value="CLV/PM"/> <p>Sets the offset between encoder offset and the rotor magnetic axis.</p>	Default: 0.0 deg Min.: -180.0 Max.: 180.0	146

<1> Available in drive software versions 1015 and later.

<2> The setting range is determined by parameter A1-02, Control Method Selection.

<3> Default setting is dependent on parameters A1-02, Control Method Selection, and o2-04, Drive Model Selection.

<4> Default setting is dependent on parameter o2-04, Drive Model Selection.

<5> Values shown are specific to 200 V class drives. Double the value for 400 V class drives. Multiply the value by 2.875 for 600 V class drives.

<6> Default setting is dependent on parameter T2-02, PM Motor Code Selection, and the drive capacity.

◆ T3: ASR and Inertia Tuning

No. (Addr. Hex)	Name	Description	Values	Page
T3-01 (760) <>	Test Signal Frequency	<input type="radio"/> V/f <input type="radio"/> V/f w PG <input type="radio"/> OLV <input checked="" type="radio"/> CLV <input type="radio"/> OLV/PM <input type="radio"/> AOLV/PM <input checked="" type="radio"/> CLV/PM Sets the frequency of the test signal used during Inertia Tuning and ASR Gain Auto-Tuning. Reduce this value if the inertia is large or if a fault occurs.	Default: 3.0 Hz Min.: 0.1 Max.: 20.0	146
T3-02 (761) <>	Test Signal Amplitude	<input type="radio"/> V/f <input type="radio"/> V/f w PG <input type="radio"/> OLV <input checked="" type="radio"/> CLV <input type="radio"/> OLV/PM <input type="radio"/> AOLV/PM <input checked="" type="radio"/> CLV/PM Sets the amplitude of the test signal used during Inertia and ASR Gain Auto-Tuning. Reduce this value if the inertia is too large or if a fault occurs.	Default: 0.5 rad Min.: 0.1 Max.: 10.0	146
T3-03 (762) <>	Motor Inertia	<input type="radio"/> V/f <input type="radio"/> V/f w PG <input type="radio"/> OLV <input checked="" type="radio"/> CLV <input type="radio"/> OLV/PM <input type="radio"/> AOLV/PM <input checked="" type="radio"/> CLV/PM Sets the motor inertia. Default setting is the inertia of a Yaskawa motor.	Default: <> <> Min.: 0.0001 kgm ² Max.: 600.00 kgm ²	147
T3-04 (763) <>	System Response Frequency	<input type="radio"/> V/f <input type="radio"/> V/f w PG <input type="radio"/> OLV <input checked="" type="radio"/> CLV <input type="radio"/> OLV/PM <input type="radio"/> AOLV/PM <input checked="" type="radio"/> CLV/PM Sets the response frequency of the mechanical system connected to the motor. Oscillation may result if set too high.	Default: 10.0 Hz Min.: 0.1 Max.: 50.0	147

<1> Displayed only when performing Inertia Tuning or ASR Gain Auto-Tuning (T1-01 = 8 or T2-01 = 9).

<2> Default setting is dependent on parameter E5-01, Motor Code Selection.

<3> Default setting is dependent on parameters C6-01, Drive Duty Selection, and o2-04, Drive Model Selection.

B.15 U: Monitors

Monitor parameters allow the user to view drive status, fault information, and other data concerning drive operation.

◆ U1: Operation Status Monitors

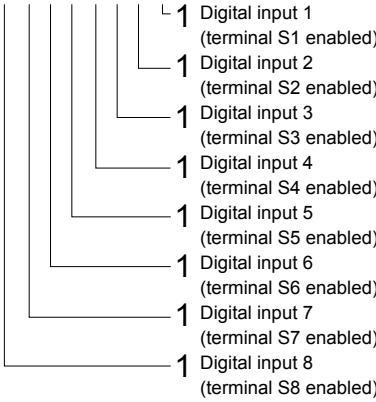
No. (Addr. Hex)	Name	Description	Analog Output Level	Unit
U1-01 (40)	Frequency Reference	All Modes Monitors the frequency reference. Display units are determined by o1-03.	10 V: Max frequency	0.01 Hz
U1-02 (41)	Output Frequency	All Modes Displays the output frequency. Display units are determined by o1-03.	10 V: Max frequency	0.01 Hz
U1-03 (42)	Output Current	All Modes Displays the output current. Note: The unit is expressed in 1 A for models 4A0930 and 4A1200.	10 V: Drive rated current	<> <>
U1-04 (43)	Control Method	All Modes 0: V/f Control 1: V/f Control with PG 2: Open Loop Vector Control 3: Closed Loop Vector Control	No signal output available	—
U1-05 (44)	Motor Speed	<input type="radio"/> V/f <input checked="" type="radio"/> V/f w PG <input checked="" type="radio"/> OLV <input checked="" type="radio"/> CLV <input type="radio"/> OLV/PM <input checked="" type="radio"/> AOLV/PM <input checked="" type="radio"/> CLV/PM Displays the motor speed feedback. Display units are determined by o1-03.	10 V: Max frequency	0.01 Hz
U1-06 (45)	Output Voltage Reference	All Modes Displays the output voltage.	10 V: 200 Vrms <>	0.1 Vac
U1-07 (46)	DC Bus Voltage	All Modes Displays the DC bus voltage.	10 V: 400 V <>	1 Vdc
U1-08 (47)	Output Power	All Modes Displays the output power (this value is calculated internally).	10 V: Drive capacity (motor capacity) kW	<>
U1-09 (48)	Torque Reference	<input type="radio"/> V/f <input type="radio"/> V/f w PG <input checked="" type="radio"/> OLV <input checked="" type="radio"/> CLV <input type="radio"/> OLV/PM <input checked="" type="radio"/> AOLV/PM <input checked="" type="radio"/> CLV/PM Monitors the internal torque reference.	10 V: Motor rated torque	0.1%
U1-10 (49)	Input Terminal Status	All Modes Displays the input terminal status. U1 - 10 = 00000000 	No signal output available	—

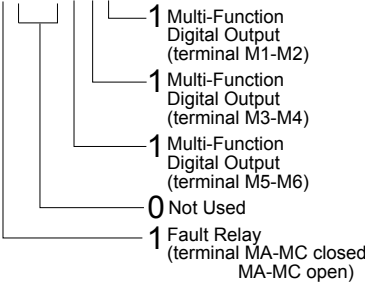
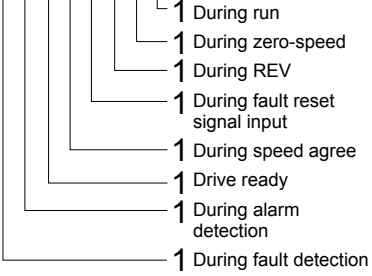
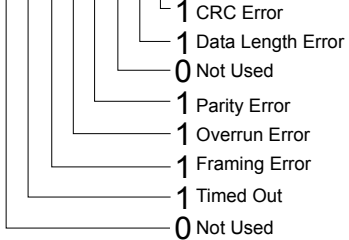
No. (Addr. Hex)	Name	Description	Analog Output Level	Unit
U1-11 (4A)	Output Terminal Status	<p>All Modes Displays the output terminal status.</p> <p>U1 - 11 = 00000000</p> 	No signal output available	-
U1-12 (4B)	Drive Status	<p>All Modes Verifies the drive operation status.</p> <p>U1 - 12 = 00000000</p> 	No signal output available	-
U1-13 (4E)	Terminal A1 Input Level	<p>All Modes Displays the signal level to analog input terminal A1.</p>	10 V: 100%	0.1%
U1-14 (4F)	Terminal A2 Input Level	<p>All Modes Displays the signal level to analog input terminal A2.</p>	10 V: 100%	0.1%
U1-15 (50)	Terminal A3 Input Level	<p>All Modes Displays the signal level to analog input terminal A3.</p>	10 V: 100%	0.1%
U1-16 (53)	Output Frequency after Soft Starter	<p>All Modes Displays output frequency with ramp time and S-curves. Units determined by o1-03.</p>	10 V: Max frequency	0.01 Hz
U1-17 (58)	DI-A3 Input Status	<p>All Modes Displays the reference value input from the DI-A3 option card. Display will appear in hexadecimal as determined by the digital card input selection in F3-01. 3FFFF: Set (1 bit) + sign (1 bit) + 16 bit</p>	No signal output available	-
U1-18 (61)	oPE Fault Parameter	<p>All Modes Displays the parameter number that caused the oPE02 or oPE08 operation error.</p>	No signal output available	-
U1-19 (66)	MEMOBUS/Modbus Error Code	<p>All Modes Displays the contents of a MEMOBUS/Modbus error.</p> <p>U1 - 19 = 00000000</p> 	No signal output available	-

Parameter List

B

B.15 U: Monitors

No. (Addr. Hex)	Name	Description	Analog Output Level	Unit
U1-21 (77)	AI-A3 Terminal V1 Input Voltage Monitor	All Modes Displays the input voltage to terminal V1 on analog input card AI-A3.	10 V: 100%	0.1%
U1-22 (72A)	AI-A3 Terminal V2 Input Voltage Monitor	All Modes Displays the input voltage to terminal V2 on analog input card AI-A3.	10 V: 100%	0.1%
U1-23 (72B)	AI-A3 Terminal V3 Input Voltage Monitor	All Modes Displays the input voltage to terminal V3 on analog input card AI-A3.	10 V: 100%	0.1%
U1-24 (7D)	Input Pulse Monitor	All Modes Displays the frequency to pulse train input terminal RP.	Determined by H6-02	1 Hz
U1-25 (4D)	Software Number (Flash)	All Modes FLASH ID	No signal output available	–
U1-26 (5B)	Software No. (ROM)	All Modes ROM ID	No signal output available	–
U1-29 (7AA)	Software No. (PWM)	All Modes PWM ID Note: This parameter is only available in models 4A0930 and 4A1200.	No signal output available	–

- <1> The number of decimal places in the parameter value depends on the drive model and the ND/HD selection in parameter C6-01. This value has two decimal places (0.01 A) if the drive is set for a maximum applicable motor capacity up to and including 11 kW, and one decimal place (0.1 A) if the maximum applicable motor capacity is higher than 11 kW.
- <2> When reading the value of this monitor via MEMOBUS/Modbus, a value of 8192 is equal to 100% of the drive rated output current.
- <3> Values shown are specific to 200 V class drives. Double the value for 400 V class drives. Multiply the value by 2.875 for 600 V class drives.
- <4> The display resolution depends on the ND/HD selection in parameter C6-01. This value has two decimal places (0.01 kW) if the drive is set for a maximum applicable motor capacity up to and including 11 kW, and one decimal place (0.1 kW) if the maximum applicable motor capacity is higher than 11 kW.

◆ U2: Fault Trace

No. (Addr. Hex)	Name	Description	Analog Output Level	Unit
U2-01 (80)	Current Fault	All Modes Displays the current fault.	No signal output available	–
U2-02 (81)	Previous Fault	All Modes Displays the previous fault.	No signal output available	–
U2-03 (82)	Frequency Reference at Previous Fault	All Modes Displays the frequency reference at the previous fault.	No signal output available	0.01 Hz
U2-04 (83)	Output Frequency at Previous Fault	All Modes Displays the output frequency at the previous fault.	No signal output available	0.01 Hz
U2-05 (84)	Output Current at Previous Fault	All Modes Displays the output current at the previous fault. Note: The unit is expressed in 1 A for models 4A0930 and 4A1200.	No signal output available	<1> <2>
U2-06 (85)	Motor Speed at Previous Fault	V/f V/f w PG OLV CLV OLV/PM AOLV/PM CLV/PM Displays the motor speed at the previous fault.	No signal output available	0.01 Hz
U2-07 (86)	Output Voltage at Previous Fault	All Modes Displays the output voltage at the previous fault.	No signal output available	0.1 Vac
U2-08 (87)	DC Bus Voltage at Previous Fault	All Modes Displays the DC bus voltage at the previous fault.	No signal output available	1 Vdc
U2-09 (88)	Output Power at Previous Fault	All Modes Displays the output power at the previous fault.	No signal output available	0.1 kW

No. (Addr. Hex)	Name	Description	Analog Output Level	Unit
U2-10 (89)	Torque Reference at Previous Fault	<div style="display: flex; justify-content: space-between; align-items: center;"> V/f V/f w PG OLV CLV </div> <div style="display: flex; justify-content: space-between; align-items: center;"> OLV/PM AOLV/PM CLV/PM </div> Displays the torque reference at the previous fault.	No signal output available	0.1%
U2-11 (8A)	Input Terminal Status at Previous Fault	<div style="display: flex; justify-content: space-between; align-items: center;"> All Modes </div> Displays the input terminal status at the previous fault. Displayed as in U1-10.	No signal output available	–
U2-12 (8B)	Output Terminal Status at Previous Fault	<div style="display: flex; justify-content: space-between; align-items: center;"> All Modes </div> Displays the output status at the previous fault. Displays the same status displayed in U1-11.	No signal output available	–
U2-13 (8C)	Drive Operation Status at Previous Fault	<div style="display: flex; justify-content: space-between; align-items: center;"> All Modes </div> Displays the operation status of the drive at the previous fault. Displays the same status displayed in U1-12.	No signal output available	–
U2-14 (8D)	Cumulative Operation Time at Previous Fault	<div style="display: flex; justify-content: space-between; align-items: center;"> All Modes </div> Displays the cumulative operation time at the previous fault.	No signal output available	1 h
U2-15 (7E0)	Soft Starter Speed Reference at Previous Fault	<div style="display: flex; justify-content: space-between; align-items: center;"> All Modes </div> Displays the speed reference for the soft starter at the previous fault.	No signal output available	0.01 Hz
U2-16 (7E1)	Motor q-Axis Current at Previous Fault	<div style="display: flex; justify-content: space-between; align-items: center;"> V/f V/f w PG OLV CLV </div> <div style="display: flex; justify-content: space-between; align-items: center;"> OLV/PM AOLV/PM CLV/PM </div> Displays the q-axis current for the motor at the previous fault.	No signal output available	0.10%
U2-17 (7E2)	Motor d-Axis Current at Previous Fault	<div style="display: flex; justify-content: space-between; align-items: center;"> V/f V/f w PG OLV CLV </div> <div style="display: flex; justify-content: space-between; align-items: center;"> OLV/PM AOLV/PM CLV/PM </div> Displays the d-axis current for the motor at the previous fault.	No signal output available	0.10%
U2-19 (7EC)	Rotor Deviation at Previous Fault	<div style="display: flex; justify-content: space-between; align-items: center;"> V/f V/f w PG OLV CLV </div> <div style="display: flex; justify-content: space-between; align-items: center;"> OLV/PM AOLV/PM CLV/PM </div> Displays the degree of rotor deviation when the most recent fault occurred (same status will appear as shown in U6-10).	No signal output available	0.1 deg
U2-20 (8E)	Heatsink Temperature at Previous Fault	<div style="display: flex; justify-content: space-between; align-items: center;"> All Modes </div> Displays the temperature of the heatsink when the most recent fault occurred.	No signal output available	1 °C
U2-27 (7FA)	Motor Temperature at Previous Fault (NTC)	<div style="display: flex; justify-content: space-between; align-items: center;"> All Modes </div> Displays the temperature of the motor when the most recent fault occurred. Note: This parameter is only available in models 4A0930 and 4A1200.	No signal output available	1 °C
U2-28 (7FC)	Malfunctioned Module	<div style="display: flex; justify-content: space-between; align-items: center;"> All Modes </div> Display the module where the previous fault occurred at a decimal number. Note: This parameter is only available in models 4A0930 and 4A1200.	No signal output available	–

<1> The number of decimal places in the parameter value depends on the drive model and the ND/HD selection in parameter C6-01. This value has two decimal places (0.01 A) if the drive is set for a maximum applicable motor capacity up to and including 11 kW, and one decimal place (0.1 A) if the maximum applicable motor capacity is higher than 11 kW.

<2> When reading the value of this monitor via MEMOBUS/Modbus, a value of 8192 is equal to 100% of the drive rated output current.

◆ U3: Fault History

No. (Addr. Hex)	Name	Description	Analog Output Level	Unit
U3-01 to U3-04 (90 to 93 (800 to 803))	First to 4th Most Recent Fault	All Modes Displays the first to the fourth most recent faults.	No signal output available	–
U3-05 to U3-10 (804 to 809)	5th to 10th Most Recent Fault	All Modes Displays the fifth to the tenth most recent faults. After ten faults, data for the oldest fault is deleted. The most recent fault appears in U3-01, with the next most recent fault appearing in U3-02. The data is moved to the next monitor parameter each time a fault occurs.	No signal output available	–
U3-11 to U3-14 (94 to 97 (80A to 80D))	Cumulative Operation Time at 1st to 4th Most Recent Fault	All Modes Displays the cumulative operation time when the first to the fourth most recent faults occurred.	No signal output available	1 h
U3-15 to U3-20 (80E to 813)	Cumulative Operation Time at 5th to 10th Most Recent Fault	All Modes Displays the cumulative operation time when the fifth to the tenth most recent faults occurred.	No signal output available	1 h

◆ U4: Maintenance Monitors

No. (Addr. Hex)	Name	Description	Analog Output Level	Unit
U4-01 (4C)	Cumulative Operation Time	All Modes Displays the cumulative operation time of the drive. The value for the cumulative operation time counter can be reset in parameter o4-01. Use parameter o4-02 to determine if the operation time should start as soon as the power is switched on or only while the Run command is present. The maximum number displayed is 99999, after which the value is reset to 0.	No signal output available	1 h
U4-02 (75)	Number of Run Commands	All Modes Displays the number of times the Run command is entered. Reset the number of Run commands using parameter o4-13. This value will reset to 0 and start counting again after reaching 65535.	No signal output available	1 Time
U4-03 (67)	Cooling Fan Operation Time	All Modes Displays the cumulative operation time of the cooling fan. The default value for the fan operation time is reset in parameter o4-03. This value will reset to 0 and start counting again after reaching 99999.	No signal output available	1 h
U4-04 (7E)	Cooling Fan Maintenance	All Modes Displays main cooling fan usage time as a percentage of its expected performance life. Parameter o4-03 can be used to reset this monitor. Replace the fan when this monitor reaches 90%.	No signal output available	1%
U4-05 (7C)	Capacitor Maintenance	All Modes Displays main circuit capacitor usage time as a percentage of their expected performance life. Parameter o4-05 can be used to reset this monitor. Replace the capacitor when this monitor reaches 90%.	No signal output available	1%
U4-06 (7D6)	Soft Charge Bypass Relay Maintenance	All Modes Displays the soft charge bypass relay maintenance time as a percentage of its estimated performance life. Parameter o4-07 can be used to reset this monitor. Replace the soft charge bypass relay when this monitor reaches 90%.	No signal output available	1%
U4-07 (7D7)	IGBT Maintenance	All Modes Displays IGBT usage time as a percentage of the expected performance life. Parameter o4-09 can be used to reset this monitor. Replace the IGBT when this monitor reaches 90%.	No signal output available	1%
U4-08 (68)	Heatsink Temperature	All Modes Displays the heatsink temperature.	10 V: 100 °C	1 °C

No. (Addr. Hex)	Name	Description	Analog Output Level	Unit
U4-09 (5E)	LED Check	All Modes Lights all segments of the LED to verify that the display is working properly.	No signal output available	–
U4-10 (5C)	kWh, Lower 4 Digits	All Modes Monitors the drive output power. The value is shown as a 9-digit number displayed across two monitor parameters, U4-10 and U4-11. Example: 12345678.9 kWh is displayed as: U4-10: 678.9 kWh U4-11: 12345 MWh	No signal output available	1 kWh
U4-11 (5D)	kWh, Upper 5 Digits		No signal output available	1 MWh
U4-13 (7CF)	Peak Hold Current	All Modes Displays the highest current value that occurred during run. Note: The unit is expressed in 1 A for models 4A0930 and 4A1200.	No signal output available	0.01 A <I>
U4-14 (7D0)	Peak Hold Output Frequency	All Modes Displays the output frequency when the current value shown in U4-13 occurred.	No signal output available	0.01 Hz
U4-16 (7D8)	Motor Overload Estimate (oL1)	All Modes Shows the value of the motor overload detection accumulator. 100% is equal to the oL1 detection level.	10 V: 100%	0.1%
U4-18 (7DA)	Frequency Reference Source Selection	All Modes Displays the source for the frequency reference as XY-nn. X: indicates which reference is used: 1 = Reference 1 (b1-01) 2 = Reference 2 (b1-15) Y-nn: indicates the reference source 0-01 = Digital operator 1-00 = Analog (Not displayed in models 4A0930 and 4A1200) 1-01 = Analog (terminal A1) 1-02 = Analog (terminal A2) 1-03 = Analog (terminal A3) 2-02 to 17 = Multi-step speed (d1-02 to 17) 3-01 = MEMOBUS/Modbus communications 4-01 = Communication option card 5-01 = Pulse input 7-01 = DWEZ 9-01 = Up/Down Command (Not displayed in models 4A0930 and 4A1200)	No signal output available	–
U4-19 (7DB)	Frequency Reference from MEMOBUS/Modbus Comm.	All Modes Displays the frequency reference provided by MEMOBUS/Modbus (decimal).	No signal output available	0.01%
U4-20 (7DC)	Option Frequency Reference	All Modes Displays the frequency reference input by an option card (decimal).	No signal output available	–

B.15 U: Monitors

No. (Addr. Hex)	Name	Description	Analog Output Level	Unit
U4-21 (7DD)	Run Command Source Selection	<p>All Modes</p> <p>Displays the source for the Run command as XY-nn. X: Indicates which Run source is used: 1 = Reference 1 (b1-02) 2 = Reference 2 (b1-16) Y: Input power supply data 0 = Digital operator 1 = External terminals 3 = MEMOBUS/Modbus communications 4 = Communication option card 7 = DWEZ nn: Run command limit status data 00: No limit status. 01: Run command was left on when stopped in the PRG mode 02: Run command was left on when switching from LOCAL to REMOTE operation 03: Waiting for soft charge bypass contactor after power up (Uv or Uv1 flashes after 10 s) 04: Waiting for “Run command prohibited” time period to end 05: Fast Stop (digital input, digital operator) 06: b1-17 (Run command given at power-up) 07: During baseblock while coast to stop with timer 08: Frequency reference is below minimal reference during baseblock 09: Waiting for Enter command</p>	No signal output available	–
U4-22 (7DE)	MEMOBUS/Modbus Communications Reference	<p>All Modes</p> <p>Displays the drive control data set by MEMOBUS/Modbus communications register no. 0001H as a four-digit hexadecimal number.</p>	No signal output available	–
U4-23 (7DF)	Communication Option Card Reference	<p>All Modes</p> <p>Displays drive control data set by an option card as a four-digit hexadecimal number.</p>	No signal output available	–
U4-32 (7FB)	Motor Temperature (NTC)	<p>All Modes</p> <p>Displays the motor temperature (NTC). U4-32 will display “20 °C” when a multi-function analog input is not set for motor thermistor input (H1-□□ = 17H). Note: This parameter is displayed in models 4A0930 and 4A1200.</p>	200 °C	1 °C
U4-37 (1044)	oH Alarm Location Monitor	<p>All Modes</p> <p>Displays the module where the oH alarm occurred as a binary number. Note: This parameter is displayed in models 4A0930 and 4A1200.</p>	No signal output available	–
U4-38 (1045)	FAn Alarm Location Monitor	<p>All Modes</p> <p>Displays the module where the FAn alarm occurred as a binary number. Note: This parameter is displayed in models 4A0930 and 4A1200.</p>	No signal output available	–
U4-39 (1046)	voF Alarm Location Monitor	<p>All Modes</p> <p>Displays the module where the voF alarm occurred as a binary number. Note: This parameter is displayed in models 4A0930 and 4A1200.</p>	No signal output available	–

<1> When reading the value of this monitor via MEMOBUS/Modbus, a value of 8192 is equal to 100% of the drive rated output current.

◆ U5: PID Monitors

No. (Addr. Hex)	Name	Description	Analog Output Level	Unit
U5-01 (57)	PID Feedback	<p>All Modes</p> <p>Displays the PID feedback value.</p>	10 V: 100%	0.01%
U5-02 (63)	PID Input	<p>All Modes</p> <p>Displays the amount of PID input (deviation between PID setpoint and feedback).</p>	10 V: 100%	0.01%
U5-03 (64)	PID Output	<p>All Modes</p> <p>Displays PID control output.</p>	10 V: 100%	0.01%

No. (Addr. Hex)	Name	Description	Analog Output Level	Unit
U5-04 (65)	PID Setpoint	All Modes Displays the PID setpoint.	10 V: 100%	0.01%
U5-05 (7D2)	PID Differential Feedback	All Modes Displays the 2nd PID feedback value if differential feedback is used (H3-□□ = 16).	10 V: 100%	0.01%
U5-06 (7D3)	PID Adjusted Feedback	All Modes Displays the difference of both feedback values if differential feedback is used (U5-01 - U5-05). If differential feedback is not used, then U5-01 and U5-06 will be the same.	10 V: 100%	0.01%
U5-21 (872) <1>	Automatically Calculated Energy Saving Coefficient Ki Value	<input type="radio"/> V/f <input type="radio"/> V/f w PG <input type="radio"/> OLV <input type="radio"/> CLV <input type="radio"/> OLV/PM <input checked="" type="radio"/> AOLV/PM <input checked="" type="radio"/> CLV/PM Displays the energy saving coefficient Ki value. Note: This parameter is not available in models 4A0930 and 4A1200.	No signal output available	0.01
U5-22 (873) <1>	Automatically Calculated Energy Saving Coefficient Kt Value	<input type="radio"/> V/f <input type="radio"/> V/f w PG <input type="radio"/> OLV <input type="radio"/> CLV <input type="radio"/> OLV/PM <input checked="" type="radio"/> AOLV/PM <input checked="" type="radio"/> CLV/PM Displays the energy saving coefficient Kt value.	No signal output available	0.01

<1> Available in drive software versions 1015 and later.

◆ U6: Operation Status Monitors

No. (Addr. Hex)	Name	Description	Analog Output Level	Unit
U6-01 (51)	Motor Secondary Current (Iq)	All Modes Displays the value of the motor secondary current (Iq). Motor rated secondary current is 100%.	10 V: Motor secondary rated current	0.1%
U6-02 (52)	Motor Excitation Current (Id)	<input type="radio"/> V/f <input type="radio"/> V/f w PG <input checked="" type="radio"/> OLV <input checked="" type="radio"/> CLV <input checked="" type="radio"/> OLV/PM <input checked="" type="radio"/> AOLV/PM <input checked="" type="radio"/> CLV/PM Displays the value calculated for the motor excitation current (Id). Motor rated secondary current is 100%.	10 V: Motor secondary rated current	0.1%
U6-03 (54)	ASR Input	<input type="radio"/> V/f <input checked="" type="radio"/> V/f w PG <input type="radio"/> OLV <input checked="" type="radio"/> CLV <input type="radio"/> OLV/PM <input checked="" type="radio"/> AOLV/PM <input checked="" type="radio"/> CLV/PM	10 V: Max frequency	0.01%
U6-04 (55)	ASR Output	Displays the input and output values when using ASR control.	10 V: Motor secondary rated current	
U6-05 (59)	Output Voltage Reference (Vq)	<input type="radio"/> V/f <input type="radio"/> V/f w PG <input checked="" type="radio"/> OLV <input checked="" type="radio"/> CLV <input checked="" type="radio"/> OLV/PM <input checked="" type="radio"/> AOLV/PM <input checked="" type="radio"/> CLV/PM Output voltage reference (Vq) for the q-Axis.	10 V: 200 Vrms <1>	0.1 Vac
U6-06 (5A)	Output Voltage Reference (Vd)	<input type="radio"/> V/f <input type="radio"/> V/f w PG <input checked="" type="radio"/> OLV <input checked="" type="radio"/> CLV <input checked="" type="radio"/> OLV/PM <input checked="" type="radio"/> AOLV/PM <input checked="" type="radio"/> CLV/PM Output voltage reference (Vd) for the d-Axis.	10 V: 200 Vrms <1>	0.1 Vac
U6-07 (5F)	q-Axis ACR Output	<input type="radio"/> V/f <input type="radio"/> V/f w PG <input checked="" type="radio"/> OLV <input checked="" type="radio"/> CLV <input type="radio"/> OLV/PM <input checked="" type="radio"/> AOLV/PM <input checked="" type="radio"/> CLV/PM Displays the output value for current control relative to motor secondary current (q-Axis).	10 V: 200 Vrms <1>	0.1%
U6-08 (60)	d-Axis ACR Output	<input type="radio"/> V/f <input type="radio"/> V/f w PG <input checked="" type="radio"/> OLV <input checked="" type="radio"/> CLV <input type="radio"/> OLV/PM <input checked="" type="radio"/> AOLV/PM <input checked="" type="radio"/> CLV/PM Displays the output value for current control relative to motor secondary current (d-Axis).	110 V: 200 Vrms <1>	0.1%
U6-09 (7C0)	Advance Phase Compensation (Δθ)	<input type="radio"/> V/f <input type="radio"/> V/f w PG <input type="radio"/> OLV <input type="radio"/> CLV <input type="radio"/> OLV/PM <input checked="" type="radio"/> AOLV/PM <input type="radio"/> CLV/PM Displays the degree of forward phase correction after calculating the deviation of Δθ _{comp} .	10 V: 180 deg -10 V: -180 deg	0.1 deg

Parameter List

B

B.15 U: Monitors

No. (Addr. Hex)	Name	Description	Analog Output Level	Unit
U6-10 (7C1)	Control Axis Deviation ($\Delta\theta$)	<input type="radio"/> V/f <input type="radio"/> V/f w PG <input type="radio"/> OLV <input type="radio"/> CLV <input type="radio"/> OLV/PM <input checked="" type="radio"/> AOLV/PM <input type="radio"/> CLV/PM Displays the amount of deviation between the actual d-Axis / q-Axis and the γ -Axis / δ -Axis used for motor control.	10 V: 180 deg -10 V: -180 deg	0.1 deg
U6-13 (7CA)	Flux Position Detection (sensor)	<input type="radio"/> V/f <input type="radio"/> V/f w PG <input type="radio"/> OLV <input type="radio"/> CLV <input type="radio"/> OLV/PM <input type="radio"/> AOLV/PM <input checked="" type="radio"/> CLV/PM Monitors the value of the flux position detection (sensor).	10 V: 180 deg -10 V: -180 deg	0.1 deg
U6-14 (7CB)	Flux Position Estimation (observer)	<input type="radio"/> V/f <input type="radio"/> V/f w PG <input type="radio"/> OLV <input type="radio"/> CLV <input type="radio"/> OLV/PM <input checked="" type="radio"/> AOLV/PM <input type="radio"/> CLV/PM Monitors the value of the flux position estimation.	10 V: 180 deg -10 V: -180 deg	0.1 deg
U6-18 (7CD)	Speed Detection PG1 Counter	<input checked="" type="radio"/> All Modes Monitors the number of pulses for speed detection (PG1).	10 V: 65536	1 pulse
U6-19 (7E5)	Speed Detection PG2 Counter	<input checked="" type="radio"/> All Modes Monitors the number of pulses for speed detection (PG2).	10 V: 65536	1 pulse
U6-20 (7D4)	Frequency Reference Bias (Up/Down 2)	<input checked="" type="radio"/> All Modes Displays the bias value used to adjust the frequency reference.	10 V: Max frequency	0.1%
U6-21 (7D5)	Offset Frequency	<input checked="" type="radio"/> All Modes Displays the frequency added to the main frequency reference.	–	0.1%
U6-22 (62)	Zero Servo Pulse Movement	<input type="radio"/> V/f <input type="radio"/> V/f w PG <input type="radio"/> OLV <input checked="" type="radio"/> CLV <input type="radio"/> OLV/PM <input type="radio"/> AOLV/PM <input checked="" type="radio"/> CLV/PM Displays how far the rotor has moved from its last position in PG pulses (multiplied by 4).	10 V: No. of pulses per revolution	1
U6-25 (6B)	Feedback Control Output	<input type="radio"/> V/f <input type="radio"/> V/f w PG <input type="radio"/> OLV <input checked="" type="radio"/> CLV <input type="radio"/> OLV/PM <input type="radio"/> AOLV/PM <input checked="" type="radio"/> CLV/PM Output monitor for the ASR speed loop.	10 V: Motor secondary rated current	0.01%
U6-26 (6C)	Feed Forward Control Output	<input type="radio"/> V/f <input type="radio"/> V/f w PG <input type="radio"/> OLV <input checked="" type="radio"/> CLV <input type="radio"/> OLV/PM <input type="radio"/> AOLV/PM <input checked="" type="radio"/> CLV/PM Output monitor for Feed Forward control.	10 V: Motor secondary rated current	0.01%
U6-57 (7C4)	Integrated Current Deviation during Judging Polarity	<input type="radio"/> V/f <input type="radio"/> V/f w PG <input type="radio"/> OLV <input type="radio"/> CLV <input type="radio"/> OLV/PM <input checked="" type="radio"/> AOLV/PM <input checked="" type="radio"/> CLV/PM Displays the deviation from the integrated current when judging motor polarity. If this value is lower than 819, then increase the value set to n8-84. The value 8192 is equivalent to the motor rated current.	No signal output available	1

<1> Values shown are specific to 200 V class drives. Double the values for 400 V class drives. Multiply the values by 2.875 for 600 V class drives.

Note: Fault histories are not kept when CPF00, CPF01, CPF06, CPF24, oFA00, oFb00, oFC00, Uv1, Uv2, or Uv3 occur.

◆ U8: DriveWorksEZ Monitors

No. (Addr. Hex)	Name	Description	Analog Output Level	Unit
U8-01 to U8-10 (1950 to 1959)	DriveWorksEZ Custom Monitor 1 to 10	<input checked="" type="radio"/> All Modes DriveWorksEZ Custom Monitor 1 to 10	10 V: 100%	0.01%
U8-11 to U8-13 (195A to 195C)	DriveWorksEZ Version Control Monitor 1 to 3	<input checked="" type="radio"/> All Modes DriveWorksEZ Version Control Monitor 1 to 3	No signal output available	–

B.16 Control Mode Dependent Parameter Default Values

The tables below list parameters that depend on the control mode selection (A1-02 for motor 1, E3-01 for motor 2). Changing the control mode initializes these parameters to the values shown here.

◆ A1-02 (Motor 1 Control Mode) Dependent Parameters

Table B.3 A1-02 (Motor 1 Control Mode) Dependent Parameters and Default Values

No.	Name	Setting Range	Resolution	Control Modes (A1-02)			
				V/f (0)	V/f w/PG (1)	OLV (2)	CLV (3)
b2-01	DC Injection Braking Start Frequency	0.0 to 10.0	0.1 Hz	0.5	0.5	0.5	0.5
b2-04	DC Injection Braking Time at Stop	0.00 to 10.00	0.01 s	0.50	0.50	0.50	0.50
b3-01	Speed Search Selection at Start	0 to 1	–	0	1	0	1
b3-02	Speed Search Deactivation Current	0 to 200	1%	120	–	100	–
b3-08	Current Control Gain during Speed Search (Speed Estimation Type)	0.00 to 6.00	–	0.8	0.8	0.8	0.8
b3-14	Bi-Directional Speed Search Selection	0 to 1	1	1	0	1	1
b5-15	PID Sleep Function Start Level	0.0 to 400.0	0.1	0.0 Hz	0.0 Hz	0.0 Hz	0.0 Hz
b6-01	Dwell Reference at Start	0.0 to 400.0	0.1	0.0 Hz	0.0 Hz	0.0 Hz	0.0 Hz
b6-03	Dwell Reference at Stop	0.0 to 400.0	0.1	0.0 Hz	0.0 Hz	0.0 Hz	0.0 Hz
b8-01	Energy Saving Control Selection	0 to 1	–	0	0	0	0
b8-02	Energy Saving Gain	0.0 to 10.0	0.1	–	–	0.7	1.0
b8-03	Energy Saving Control Filter Time Constant	0.00 to 10.00	0.01 s	–	–	0.50 <I>	0.01 <I>
C1-11	Accel/Decel Time Switching Frequency	0.0 to 400.0	0.1	0.0 Hz	0.0 Hz	0.0 Hz	0.0 Hz
C2-01	S-Curve Time at Acceleration Start	0.00 to 10.00	0.01 s	0.20	0.20	0.20	0.20
C3-01	Slip Compensation Gain	0.0 to 2.5	0.1	0.0	–	1.0	1.0
C3-02	Slip Compensation Primary Delay Time	0 to 10000	1 ms	2000	–	200	–
C4-01	Torque Compensation Gain	0.00 to 2.50	0.01	1.00	1.00	1.00	–
C4-02	Torque Compensation Primary Delay Time	0 to 10000	1 ms	200 <2>	200 <2>	20	–
C5-01	ASR Proportional Gain 1	0.00 to 300.00 <3>	0.01	–	0.20	–	20.00
C5-02	ASR Integral Time 1	0.000 to 10.000	0.001 s	–	0.200	–	0.500
C5-03	ASR Proportional Gain 2	0.00 to 300.00	0.01	–	0.02	–	20.00
C5-04	ASR Integral Time 2	0.000 to 10.000	0.001 s	–	0.050	–	0.500
C5-06	ASR Primary Delay Time Constant	0.000 to 0.500	0.001 s	–	–	–	0.004
C5-07	ASR Gain Switching Frequency	0.0 to 400.0	0.1	–	–	–	0.0 Hz
C6-02	Carrier Frequency Selection	1 to F	–	7 <4>	7 <4>	7 <4>	7
d3-01	Jump Frequency 1	0.0 to 400.0	0.1	0.0 Hz	0.0 Hz	0.0 Hz	0.0 Hz
d3-02	Jump Frequency 2	0.0 to 400.0	0.1	0.0 Hz	0.0 Hz	0.0 Hz	0.0 Hz
d3-03	Jump Frequency 3	0.0 to 400.0	0.1	0.0 Hz	0.0 Hz	0.0 Hz	0.0 Hz
d3-04	Jump Frequency Width	0.0 to 20.0	0.1	1.0 Hz	1.0 Hz	1.0 Hz	1.0 Hz
d5-02	Torque Reference Delay Time	0 to 1000	1 ms	–	–	–	0
E1-04	Maximum Output Frequency	40.0 to 400.0	0.1 Hz	60.0	60.0	60.0	60.0
E1-05	Maximum Voltage	0.0 to 255.0 <5>	0.1 V	575 <6>	575 <6>	575	575
E1-06	Base Frequency	0.0 to 400.0	0.1 Hz	60.0	60.0	60.0	60.0
E1-07	Middle Output Frequency	0.0 to 400.0	0.1 Hz	3.0	3.0	3.0	3.0
E1-08	Middle Output Frequency Voltage	0.0 to 255.0 <5>	0.1 V	15.0 <6>	15.0 <6>	15.0	15.0
E1-09	Minimum Output Frequency	0.0 to 400.0	0.1 Hz	1.5	1.5	0.5	0.0
E1-10	Minimum Output Frequency Voltage	0.0 to 255.0 <5>	0.1 V	9.0	9.0	2.0	0.0
F1-01	PG 1 Pulses Per Revolution	0 to 60000	1 ppr	–	600	–	600
F1-05	PG 1 Rotation Selection	0 to 1	–	–	0	–	0
F1-09	Overspeed Detection Delay Time	0.0 to 2.0	0.1 s	–	1.0	–	0.0
L1-01	Motor Overload Protection Selection	0 to 4	–	1	1	1	1
L3-20	DC Bus Voltage Adjustment Gain	0.00 to 5.00	0.01	1.00	1.00	0.30	0.30

B.16 Control Mode Dependent Parameter Default Values

No.	Name	Setting Range	Resolution	Control Modes (A1-02)			
				V/f (0)	V/f w/PG (1)	OLV (2)	CLV (3)
L3-21	Accel/Decel Rate Calculation Gain	0.10 to 10.00	0.01	1.00	1.00	1.00	1.00
L3-34	Torque Limit Delay Time	0.000 to 1.000	0.001 s	–	–	–	–
L4-01	Speed Agreement Detection Level	0.0 to 400.0	0.1	0.0 Hz	0.0 Hz	0.0 Hz	0.0 Hz
L4-02	Speed Agreement Detection Width	0.0 to 20.0	0.1 Hz	2.0	2.0	2.0	2.0
L4-03	Speed Agreement Detection Level (+/-)	-400.0 to 400.0	0.1	0.0 Hz	0.0 Hz	0.0 Hz	0.0 Hz
L4-04	Speed Agreement Detection Width (+/-)	0.0 to 20.0	0.1 Hz	2.0	2.0	2.0	2.0
L8-38	Carrier Frequency Reduction Selection	0 to 2	–	<4>	<4>	<4>	<4>
L8-40	Carrier Frequency Reduction Off Delay Time	0.00 to 2.00	0.01 s	0.50	0.50	0.50	0.50
o1-03	Digital Operator Display Selection	0 to 3	–	0	0	0	0
o1-04	V/f Pattern Display Unit	0 to 1	–	—	—	—	0

<1> This setting value depends on a Maximum Applicable Motor Capacity in models 2A0250 to 2A0415, 4A0139 to 4A1200, and 5A0099 to 5A0242: 2.00 in Open Loop Vector Control, 0.05 in Closed Loop Vector Control.

<2> This setting value depends on a Maximum Applicable Motor Capacity: 1000 ms in models 2A0138 to 2A0415, 4A0139 to 4A1200, and 5A0099 to 5A0242

<3> In AOLV/PM and CLV/PM control modes, the setting range is 1.00 to 300.00.

<4> Default setting is dependent on parameter C6-01, Drive Duty Selection.

<5> Values shown are specific to 200 V class drives. Double the values for 400 V class drives. Multiply the values by 2.875 for 600 V class drives.

<6> This setting value depends on a Maximum Applicable Motor Capacity and V/f pattern selection in parameter E1-03.

Table B.4 A1-02 (Motor 1 Control Mode) Dependent Parameters and Default Values

No.	Name	Setting Range	Resolution	Control Modes (A1-02)		
				OLV/PM (5)	AOLV/PM (6)	CLV/PM (7)
b2-01	DC Injection Braking Start Frequency	0.0 to 10.0	0.1 Hz	0.5 Hz	1.0% <4>	0.5% <4>
b2-04	DC Injection Braking Time at Stop	0.00 to 10.00	0.01 s	0.00	0.00	0.00
b3-01	Speed Search Selection at Start	0 to 1	–	0	0	1
b3-02	Speed Search Deactivation Current	0 to 200	1%	–	–	–
b3-08	Current Control Gain during Speed Search (Speed Estimation Type)	0.00 to 6.00	–	0.3	0.3	0.3
b3-14	Bi-Directional Speed Search Selection	0 to 1	–	1	1	1
b5-15	PID Sleep Function Start Level	0.0 to 400.0 Hz <4>	0.1	0.0 Hz	0.0%	0.0%
b6-01	Dwell Reference at Start	0.0 to 400.0 Hz <4>	0.1	0.0 Hz	0.0%	0.0%
b6-03	Dwell Reference at Stop	0.0 to 400.0 Hz <4>	0.1	0.0 Hz	0.0%	0.0%
b8-01	Energy Saving Control Selection	0 to 1	–	–	1	1
b8-02	Energy Saving Gain	0.0 to 10.0	0.1	–	–	–
b8-03	Energy Saving Control Filter Time Constant	0.00 to 10.00	0.01 s	–	–	–
C1-11	Accel/Decel Time Switching Frequency	0.0 to 400.0 Hz <4>	0.1	0.0 Hz	0.0%	0.0%
C2-01	S-Curve Time at Acceleration Start	0.00 to 10.00	0.01 s	1.00	0.20	0.20
C3-01	Slip Compensation Gain	0.0 to 2.5	0.1	–	–	–
C3-02	Slip Compensation Primary Delay Time	0 to 10000	1 ms	–	–	–
C4-01	Torque Compensation Gain	0.00 to 2.50	0.01	0.00	–	–
C4-02	Torque Compensation Primary Delay Time	0 to 10000	1 ms	100	–	–
C5-01	ASR Proportional Gain 1	0.00 to 300.00 <4>	0.01	–	10.00	20.00
C5-02	ASR Integral Time 1	0.000 to 10.000	0.001 s	–	0.500	0.500
C5-03	ASR Proportional Gain 2	0.00 to 300.00 <4>	0.01	–	10.00	20.00
C5-04	ASR Integral Time 2	0.000 to 10.000	0.001 s	–	0.500	0.500
C5-06	ASR Primary Delay Time Constant	0.000 to 0.500	0.001 s	–	0.016	0.004
C5-07	ASR Gain Switching Frequency	0.0 to 400.0 Hz <4>	0.1	0.0 Hz	0.0%	0.0%
C6-02	Carrier Frequency Selection	1 to F	–	2	2	2
d3-01	Jump Frequency 1	0.0 to 400.0 Hz <4>	0.1	0.0 Hz	0.0%	0.0%
d3-02	Jump Frequency 2	0.0 to 400.0 Hz <4>	0.1	0.0 Hz	0.0%	0.0%

B.16 Control Mode Dependent Parameter Default Values

No.	Name	Setting Range	Resolution	Control Modes (A1-02)		
				OLV/PM (5)	AOLV/PM (6)	CLV/PM (7)
d3-03	Jump Frequency 3	0.0 to 400.0 Hz <2>	0.1	0.0 Hz	0.0%	0.0%
d3-04	Jump Frequency Width	0.0 to 20.0 <4>	0.1	1.0 Hz	1.0%	1.0%
d5-02	Torque Reference Delay Time	0 to 1000	1 ms	–	–	–
E1-04	Maximum Output Frequency	40.0 to 400.0	0.1 Hz	<5>	<5>	<5>
E1-05	Maximum Voltage	0.0 to 377.1 <6>	0.1 V	<5>	<5>	<5>
E1-06	Base Frequency	0.0 to 400.0	0.1 Hz	<5>	<5>	<5>
E1-07	Middle Output Frequency	0.0 to 400.0	0.1 Hz	–	–	–
E1-08	Middle Output Frequency Voltage	0.0 to 377.1 <6>	0.1 V	–	–	–
E1-09	Minimum Output Frequency	0.0 to 400.0	0.1 Hz	<5>	<5>	0.0
E1-10	Minimum Output Frequency Voltage	0.0 to 377.1 <6>	0.1 V	–	–	–
F1-01	PG 1 Pulses Per Revolution	0 to 60000	1 ppr	–	–	1024
F1-05	PG 1 Rotation Selection	0 to 1	–	1	1	1
F1-09	Overspeed Detection Delay Time	0.0 to 2.0	0.1 s	–	0.0	0.0
L1-01	Motor Overload Protection Selection	0 to 6	–	4	4	5
L3-20	DC Bus Voltage Adjustment Gain	0.00 to 5.00	0.01	0.65	0.65	0.65
L3-21	Accel/Decel Rate Calculation Gain	0.10 to 10.00	0.01	1.00	1.00	1.00
L3-34	Torque Limit Delay Time	0.000 to 1.000	0.001 s	–	0.200	0.020
L4-01	Speed Agreement Detection Level	0.0 to 400.0 Hz <2>	0.1	0.0 Hz	0.0%	0.0%
L4-02	Speed Agreement Detection Width	0.0 to 20.0	0.1 Hz	2.0 Hz	4.0% <1>	4.0% <1>
L4-03	Speed Agreement Detection Level (+/-)	0.0 to 400.0 Hz <7>	0.1	0.0 Hz	0.0%	0.0%
L4-04	Speed Agreement Detection Width (+/-)	0.0 to 20.0	0.1 Hz	2.0 Hz	4.0% <1>	4.0% <1>
L8-38	Carrier Frequency Reduction Selection	0 to 2	–	0	–	0
L8-40	Carrier Frequency Reduction Off Delay Time	0.00 to 2.00	0.01 s	0.00	–	0.00
o1-03	Digital Operator Display Selection	0 to 3	–	0	1	1
o1-04	V/f Pattern Display Unit	0 to 1	–	–	1	1

- <1> Value calculated as a percentage of the maximum output frequency.
- <2> In AOLV/PM and CLV/PM control modes, the setting units and range are expressed as a percentage (0.0 to 100.0%) instead of in Hz.
- <3> The setting range is 1.00 to 300.00 in AOLV/PM and CLV/PM control modes.
- <4> In AOLV/PM and CLV/PM control modes, the setting units and range are expressed as a percentage (0.0 to 40.0%) instead of in Hz.
- <5> Default setting is dependent on parameter E5-01, Motor Code Selection.
- <6> Values shown are specific to 200 V class drives. Double the values for 400 V class drives. Multiply the values by 2.875 for 600 V class drives.
- <7> In AOLV/PM and CLV/PM control modes, the setting units and range are expressed as a percentage (-100.0 to 100.0%) instead of in Hz.

B.16 Control Mode Dependent Parameter Default Values

◆ E3-01 (Motor 2 Control Mode) Dependent Parameters

Table B.5 E3-01 (Motor 2 Control Mode) Dependent Parameters and Default Values

No.	Name	Setting Range	Resolution	Control Modes (E3-01)			
				V/f (0)	V/f w/P.G (1)	OLV (2)	CLV (3)
C3-21	Motor 2 Slip Compensation Gain	0.0 to 2.5	0.1	0.0	–	1.0	1.0
C3-22	Motor 2 Slip Compensation Primary Delay Time	0 to 10000	1 ms	2000	–	200	–
C5-21	Motor 2 ASR Proportional Gain 1	0.00 to 300.00	0.01	–	0.20	–	20.00
C5-22	Motor 2 ASR Integral Time 1	0.000 to 10.000	0.001 s	–	0.200	–	0.500
C5-23	Motor 2 Proportional Gain 2	0.00 to 300.00	0.01	–	0.02	–	20.00
C5-24	Motor 2 ASR Integral Time 2	0.000 to 10.000	0.001 s	–	0.050	–	0.500
C5-26	Motor 2 Carrier Frequency Selection	1 to F	–	7 <1>	7 <1>	7 <1>	7 <1>
E3-04	Motor 2 Maximum Output Frequency	40.0 to 400.0	0.1 Hz	60.0	60.0	60.0	60.0
E3-05	Motor 2 Maximum Output Voltage <2>	0.0 to 255.0	0.1 V	200.0	200.0	200.0	200.0
E3-06	Motor 2 Base Frequency	0.0 to 400.0	0.1 Hz	60.0	60.0	60.0	60.0
E3-07	Motor 2 Mid Output Frequency	0.0 to 400.0	0.1 Hz	3.0	3.0	3.0	0.0
E3-08	Motor 2 Mid Output Frequency Voltage <2>	0.0 to 255.0	0.1 V	15.0	15.0	11.0	0.0
E3-09	Motor 2 Minimum Output Frequency	0.0 to 400.0	0.1 Hz	1.5	1.5	0.5	0.0
E3-10	Motor 2 Minimum Output Voltage <2>	0.0 to 255.0	0.1 V	9.0	9.0	2.0	0.0

<1> Default setting is determined by parameters o2-04, Drive Model Selection, and C6-01, Drive Duty Selection.

<2> Values shown here are specific to 200 V class drives. Double the value for 400 V class drives. Multiply the value by 2.875 for 600 V class drives.

B.17 V/f Pattern Default Values

The following tables show the V/f pattern setting default values depending on the control mode (A1-02) and the V/f pattern selection (E1-03 in V/f Control).

Table B.6 E1-03 V/f Pattern Settings for Drive Capacity: Models 2A0004 to 2A0021, 4A0002 to 4A0011, and 5A0003 to 5A0009

No.	Unit	V/f Control																OLV	CLV
		0	1	2	3	4	5	6	7	8	9	A	B	C	D	E	F <1>		
E1-03	-	0	1	2	3	4	5	6	7	8	9	A	B	C	D	E	F <1>	OLV	CLV
E1-04	Hz	50.0	60.0	60.0	72.0	50.0	50.0	60.0	60.0	50.0	50.0	60.0	60.0	90.0	120.0	180.0	60.0	60.0	60.0
E1-05 <2>	V	200.0	200.0	200.0	200.0	200.0	200.0	200.0	200.0	200.0	200.0	200.0	200.0	200.0	200.0	200.0	230.0	230.0	230.0
E1-06	Hz	50.0	60.0	50.0	60.0	50.0	50.0	60.0	60.0	50.0	50.0	60.0	60.0	60.0	60.0	60.0	60.0	60.0	-
E1-07	Hz	2.5	3.0	3.0	3.0	25.0	25.0	30.0	30.0	2.5	2.5	3.0	3.0	3.0	3.0	3.0	3.0	3.0	-
E1-08 <2>	V	15.0	15.0	15.0	15.0	35.0	50.0	35.0	50.0	19.0	24.0	19.0	24.0	15.0	15.0	15.0	17.3	13.8	-
E1-09	Hz	1.3	1.5	1.5	1.5	1.3	1.3	1.5	1.5	1.3	1.3	1.5	1.5	1.5	1.5	1.5	1.5	0.5	-
E1-10 <2>	V	9.0	9.0	9.0	9.0	8.0	9.0	8.0	9.0	11.0	13.0	11.0	15.0	9.0	9.0	9.0	10.2	2.9	-

<1> This value determines the default values for E1-04 through E1-10 (E3-04 through E3-10 for motor 2).

<2> Values shown here are specific to 200 V class drives. Double the value for 400 V class drives. Multiply the value by 2.875 for 600 V class drives.

Table B.7 E1-03 V/f Pattern Settings for Drive Capacity: Models 2A0030 to 2A0211, 4A0018 to 4A0103, and 5A0011 to 5A0077

No.	Unit	V/f Control																OLV	CLV
		0	1	2	3	4	5	6	7	8	9	A	B	C	D	E	F <1>		
E1-03	-	0	1	2	3	4	5	6	7	8	9	A	B	C	D	E	F <1>	OLV	CLV
E1-04	Hz	50.0	60.0	60.0	72.0	50.0	50.0	60.0	60.0	50.0	50.0	60.0	60.0	90.0	120.0	180.0	60.0	60.0	60.0
E1-05 <2>	V	200.0	200.0	200.0	200.0	200.0	200.0	200.0	200.0	200.0	200.0	200.0	200.0	200.0	200.0	200.0	230.0	230.0	230.0
E1-06	Hz	50.0	60.0	50.0	60.0	50.0	50.0	60.0	60.0	50.0	50.0	60.0	60.0	60.0	60.0	60.0	60.0	60.0	-
E1-07	Hz	2.5	3.0	3.0	3.0	25.0	25.0	30.0	30.0	2.5	2.5	3.0	3.0	3.0	3.0	3.0	3.0	3.0	-
E1-08 <2>	V	14.0	14.0	14.0	14.0	35.0	50.0	35.0	50.0	18.0	23.0	18.0	23.0	14.0	14.0	14.0	16.1	12.7	-
E1-09	Hz	1.3	1.5	1.5	1.5	1.3	1.3	1.5	1.5	1.3	1.3	1.5	1.5	1.5	1.5	1.5	1.5	0.5	-
E1-10 <2>	V	7.0	7.0	7.0	7.0	6.0	7.0	6.0	7.0	9.0	11.0	9.0	13.0	7.0	7.0	7.0	8.1	2.3	-

<1> This value determines the default values for E1-04 through E1-10 (E3-04 through E3-10 for motor 2).

<2> Values shown here are specific to 200 V class drives. Double the value for 400 V class drives. Multiply the value by 2.875 for 600 V class drives.

Table B.8 E1-03 V/f Pattern Settings for Drive Capacity: Models 2A0250 to 2A0415, 4A0139 to 4A1200, and 5A0099 to 5A0242

No.	Unit	V/f Control																OLV	CLV
		0	1	2	3	4	5	6	7	8	9	A	B	C	D	E	F <1>		
E1-03	-	0	1	2	3	4	5	6	7	8	9	A	B	C	D	E	F <1>	OLV	CLV
E1-04	Hz	50.0	60.0	60.0	72.0	50.0	50.0	60.0	60.0	50.0	50.0	60.0	60.0	90.0	120.0	180.0	60.0	60.0	60.0
E1-05 <2>	V	200.0	200.0	200.0	200.0	200.0	200.0	200.0	200.0	200.0	200.0	200.0	200.0	200.0	200.0	200.0	230.0	230.0	230.0
E1-06	Hz	50.0	60.0	50.0	60.0	50.0	50.0	60.0	60.0	50.0	50.0	60.0	60.0	60.0	60.0	60.0	60.0	60.0	-
E1-07	Hz	2.5	3.0	3.0	3.0	25.0	25.0	30.0	30.0	2.5	2.5	3.0	3.0	3.0	3.0	3.0	3.0	3.0	-
E1-08 <2>	V	12.0	12.0	12.0	12.0	35.0	50.0	35.0	50.0	15.0	20.0	15.0	20.0	12.0	12.0	12.0	13.8	12.7	-
E1-09	Hz	1.3	1.5	1.5	1.5	1.3	1.3	1.5	1.5	1.3	1.3	1.5	1.5	1.5	1.5	1.5	1.5	0.5	-

B.17 V/f Pattern Default Values

No.	Unit	V/f Control																OLV	CLV
		0	1	2	3	4	5	6	7	8	9	A	B	C	D	E	F <1>		
E1-03	-	0	1	2	3	4	5	6	7	8	9	A	B	C	D	E	F <1>	OLV	CLV
E1-10 <2>	V	6.0	6.0	6.0	6.0	5.0	6.0	5.0	6.0	7.0	9.0	7.0	11.0	6.0	6.0	6.0	6.9	2.3	-

<1> This value determines the default values for E1-04 through E1-10 (E3-04 through E3-10 for motor 2).

<2> Values shown here are specific to 200 V class drives. Double the value for 400 V class drives. Multiply the value by 2.875 for 600 V class drives.

B.18 Defaults by Drive Model and Duty Rating ND/HD

The following tables show parameters and default settings that change with the drive model selection (o2-04) and drive duty selection (C6-01). Parameter numbers shown in parenthesis are valid for motor 2.

Table B.9 200 V Class Drives Default Settings by Drive Model Selection and ND/HD settings

No.	Name	Unit	Default Settings							
			Drive Model		2A0004		2A0006		2A0008	
C6-01	Drive Duty Selection	–	HD	ND	HD	ND	HD	ND	HD	ND
o2-04	Drive Model Selection	Hex.	62		63		64		65	
E2-11 (E4-11)	Motor Rated Output	kW (HP)	0.4 (0.75)	0.75 (0.75)	0.75 (1)	1.1 (1)	1.1 (2)	1.5 (2)	1.5 (2)	2.2 (3)
b3-04	V/f Gain during Speed Search	%	100	100	100	100	100	100	100	100
b3-06	Output Current 1 during Speed Search	–	1	1	0.5	0.5	0.5	0.5	0.5	0.5
b3-07 </>	Output Current 2 during Speed Search (Speed Estimation Type)	–	–	–	–	–	–	–	–	–
b3-26 </>	Start Speed Search Select	–	–	–	–	–	–	–	–	–
b8-03	Energy Saving Control Filter Time Constant	s	0.50	0.50	0.50	0.50	0.50	0.50	0.50	0.50
b8-04	Energy Saving Coefficient Value	–	288.2	223.7	223.7	196.6	196.6	169.4	169.4	156.8
C5-17 (C5-37)	Motor Inertia	kgm ²	0.0015	0.0028	0.0028	0.0068	0.0068	0.0068	0.0068	0.0088
C6-02	Carrier Frequency Selection	–	1	7	1	7	1	7	1	7
E2-01 (E4-01)	Motor Rated Current	A	1.9	3.3	3.3	4.9	4.9	6.2	6.2	8.5
E2-02 (E4-02)	Motor Rated Slip	Hz	2.9	2.5	2.5	2.6	2.6	2.6	2.6	2.9
E2-03 (E4-03)	Motor No-Load Current	A	1.2	1.8	1.8	2.3	2.3	2.8	2.8	3
E2-05 (E4-05)	Motor Line-to-Line Resistance	Ω	9.842	5.156	5.156	3.577	3.577	1.997	1.997	1.601
E2-06 (E4-06)	Motor Leakage Inductance	%	18.2	13.8	13.8	18.5	18.5	18.5	18.5	18.4
E2-10 (E4-10)	Motor Iron Loss for Torque Compensation	W	14	26	26	38	38	53	53	77
E5-01	Motor Code Selection	Hex.	1202	1202	1203	1203	FFFF	FFFF	1205	1205
L2-02	Momentary Power Loss Ride-Thru Time	s	0.1	0.1	0.2	0.2	0.3	0.3	0.3	0.3
L2-03	Momentary Power Loss Minimum Baseblock Time	s	0.2	0.3	0.3	0.4	0.4	0.4	0.4	0.5
L2-04	Momentary Power Loss Voltage Recovery Time	s	0.3	0.3	0.3	0.3	0.3	0.3	0.3	0.3
L3-24	Motor Acceleration Time for Inertia Calculations	s	0.178	0.142	0.142	0.142	0.142	0.166	0.166	0.145
L8-02	Overheat Alarm Level	°C	115	115	115	115	115	115	115	115
L8-35	Installation Method Selection	–	2	2	2	2	2	2	2	2
L8-38	Carrier Frequency Reduction Selection	–	2	2	2	2	2	2	2	2
n1-03	Hunting Prevention Time Constant	ms	10	10	10	10	10	10	10	10
n5-02	Motor Acceleration Time	s	0.178	0.142	0.142	0.142	0.142	0.166	0.166	0.145

<1> This parameter is available in models 4A0930 and 4A1200.

B.18 Defaults by Drive Model and Duty Rating ND/HD

No.	Name	Unit	Default Settings							
			2A0012		2A0018		2A0021		2A0030	
–	Drive Model	–	HD	ND	HD	ND	HD	ND	HD	ND
C6-01	Drive Duty Selection	–	HD	ND	HD	ND	HD	ND	HD	ND
o2-04	Drive Model Selection	Hex.	66		67		68		6A	
E2-11 (E4-11)	Motor Rated Output	kW (HP)	2.2 (3)	3.0 (3)	3.0 (3)	3.7 (5)	3.7 (5)	5.5 (7.5)	5.5 (7.5)	7.5 (10)
b3-04	V/f Gain during Speed Search	%	100	100	100	100	100	100	100	100
b3-06	Output Current 1 during Speed Search	–	0.5	0.5	0.5	0.5	0.5	0.5	0.5	0.5
b3-07 <1>	Output Current 2 during Speed Search (Speed Estimation Type)	–	–	–	–	–	–	–	–	–
b3-26 <1>	Start Speed Search Select	–	–	–	–	–	–	–	–	–
b8-03	Energy Saving Control Filter Time Constant	s	0.50	0.50	0.50	0.50	0.50	0.50	0.50	0.50
b8-04	Energy Saving Coefficient Value	–	156.8	136.4	136.4	122.9	122.9	94.75	94.75	72.69
C5-17 (C5-37)	Motor Inertia	kgm ²	0.0088	0.0158	0.0158	0.0158	0.0158	0.0255	0.026	0.037
C6-02	Carrier Frequency Selection	–	1	7	1	7	1	7	1	7
E2-01 (E4-01)	Motor Rated Current	A	8.5	11.4	11.4	14	14	19.6	19.6	26.6
E2-02 (E4-02)	Motor Rated Slip	Hz	2.9	2.7	2.7	2.73	2.73	1.5	1.5	1.3
E2-03 (E4-03)	Motor No-Load Current	A	3	3.7	3.7	4.5	4.5	5.1	5.1	8
E2-05 (E4-05)	Motor Line-to-Line Resistance	Ω	1.601	1.034	1.034	0.771	0.771	0.399	0.399	0.288
E2-06 (E4-06)	Motor Leakage Inductance	%	18.4	19	19	19.6	19.6	18.2	18.2	15.5
E2-10 (E4-10)	Motor Iron Loss for Torque Compensation	W	77	91	91	112	112	172	172	262
E5-01	Motor Code Selection	Hex.	1206	1206	FFFF	FFFF	1208	1208	120A	120A
L2-02	Momentary Power Loss Ride-Thru Time	s	0.5	0.5	1	1	1	1	1	1
L2-03	Momentary Power Loss Minimum Baseblock Time	s	0.5	0.5	0.5	0.6	0.6	0.7	0.7	0.8
L2-04	Momentary Power Loss Voltage Recovery Time	s	0.3	0.3	0.3	0.3	0.3	0.3	0.3	0.3
L3-24	Motor Acceleration Time for Inertia Calculations	s	0.145	0.145	0.145	0.154	0.154	0.168	0.168	0.175
L8-02	Overheat Alarm Level	°C	125	125	110	110	110	110	120	120
L8-35	Installation Method Selection	–	2	2	2	2	2	2	2	2
L8-38	Carrier Frequency Reduction Selection	–	2	2	2	2	2	2	2	2
n1-03	Hunting Prevention Time Constant	ms	10	10	10	10	10	10	10	10
n5-02	Motor Acceleration Time	s	0.145	0.145	0.145	0.154	0.154	0.168	0.168	0.175

<1> This parameter is available in models 4A0930 and 4A1200.

B.18 Defaults by Drive Model and Duty Rating ND/HD

No.	Name	Unit	Default Settings							
			2A0040		2A0056		2A0069		2A0081	
–	Drive Model	–	HD	ND	HD	ND	HD	ND	HD	ND
C6-01	Drive Duty Selection	–	HD	ND	HD	ND	HD	ND	HD	ND
o2-04	Drive Model Selection	Hex.	6B		6D		6E		6F	
E2-11 (E4-11)	Motor Rated Power	kW (HP)	7.5 (10)	11 (15)	11 (15)	15 (20)	15 (20)	18.5 (25)	18.5 (25)	22 (30)
b3-04	V/f Gain during Speed Search	%	100	100	100	100	100	100	100	100
b3-06	Output Current 1 during Speed Search	–	0.5	0.5	0.5	0.5	0.5	0.5	0.5	0.5
b3-07 <1>	Output Current 2 during Speed Search (Speed Estimation Type)	–	–	–	–	–	–	–	–	–
b3-26 <1>	Start Speed Search Select	–	–	–	–	–	–	–	–	–
b8-03	Energy Saving Control Filter Time Constant	s	0.50	0.50	0.50	0.50	0.50	0.50	0.50	0.50
b8-04	Energy Saving Coefficient Value	–	72.69	70.44	70.44	63.13	63.13	57.87	57.87	51.79
C5-17 (C5-37)	Motor Inertia	kgm ²	0.037	0.053	0.053	0.076	0.076	0.138	0.138	0.165
C6-02	Carrier Frequency Selection	–	1	7	1	7	1	7	1	7
E2-01 (E4-01)	Motor Rated Current	A	26.6	39.7	39.7	53	53	65.8	65.8	77.2
E2-02 (E4-02)	Motor Rated Slip	Hz	1.3	1.7	1.7	1.6	1.6	1.67	1.67	1.7
E2-03 (E4-03)	Motor No-Load Current	A	8	11.2	11.2	15.2	15.2	15.7	15.7	18.5
E2-05 (E4-05)	Motor Line-to-Line Resistance	Ω	0.288	0.23	0.23	0.138	0.138	0.101	0.101	0.079
E2-06 (E4-06)	Motor Leakage Inductance	%	15.5	19.5	19.5	17.2	17.2	15.7	20.1	19.5
E2-10 (E4-10)	Motor Iron Loss for Torque Compensation	W	262	245	245	272	272	505	505	538
E5-01	Motor Code Selection	Hex.	120B	120B	120D	120D	120E	120E	120F	120F
L2-02	Momentary Power Loss Ride-Thru Time	s	1	1	2	2	2	2	2	2
L2-03	Momentary Power Loss Minimum Baseblock Time	s	0.8	0.9	0.9	1	1	1	1	1
L2-04	Momentary Power Loss Voltage Recovery Time	s	0.3	0.3	0.3	0.6	0.6	0.6	0.6	0.6
L3-24	Motor Acceleration Time for Inertia Calculations	s	0.175	0.265	0.265	0.244	0.244	0.317	0.317	0.355
L8-02	Overheat Alarm Level	°C	125	125	120	120	120	120	125	125
L8-35	Installation Method Selection	–	2	2	2	2	2	2	2	2
L8-38	Carrier Frequency Reduction Selection	–	2	2	2	2	2	2	2	2
n1-03	Hunting Prevention Time Constant	ms	10	10	10	10	10	10	10	10
n5-02	Motor Acceleration Time	s	0.175	0.265	0.265	0.244	0.244	0.317	0.317	0.355

<1> This parameter is available in models 4A0930 and 4A1200.

B.18 Defaults by Drive Model and Duty Rating ND/HD

No.	Name	Unit	Default Settings							
			2A0110		2A0138		2A0169		2A0211	
–	Drive Model	–	HD	ND	HD	ND	HD	ND	HD	ND
C6-01	Drive Duty Selection	–	HD	ND	HD	ND	HD	ND	HD	ND
o2-04	Drive Model Selection	Hex.	70		72		73		74	
E2-11 (E4-11)	Motor Rated Power	kW (HP)	22 (30)	30 (40)	30 (40)	37 (50)	37 (50)	45 (60)	45 (60)	55 (75)
b3-04	V/f Gain during Speed Search	%	100	80	80	80	80	80	80	80
b3-06	Output Current 1 during Speed Search	–	0.5	0.5	0.5	0.5	0.5	0.5	0.5	0.5
b3-07 <1>	Output Current 2 during Speed Search (Speed Estimation Type)	–	–	–	–	–	–	–	–	–
b3-26 <1>	Start Speed Search Select	–	–	–	–	–	–	–	–	–
b8-03	Energy Saving Control Filter Time Constant	s	0.50	0.50	0.50	0.50	0.50	0.50	0.50	2.00
b8-04	Energy Saving Coefficient Value	–	51.79	46.27	46.27	38.16	38.16	35.78	35.78	31.35
C5-17 (C5-37)	Motor Inertia	kgm ²	0.165	0.220	0.220	0.273	0.273	0.333	0.333	0.490
C6-02	Carrier Frequency Selection	–	1	7	1	7	1	7	1	7
E2-01 (E4-01)	Motor Rated Current	A	77.2	105	105	131	131	160	160	190
E2-02 (E4-02)	Motor Rated Slip	Hz	1.7	1.8	1.8	1.33	1.33	1.6	1.6	1.43
E2-03 (E4-03)	Motor No-Load Current	A	18.5	21.9	21.9	38.2	38.2	44	44	45.6
E2-05 (E4-05)	Motor Line-to-Line Resistance	Ω	0.079	0.064	0.064	0.039	0.039	0.03	0.03	0.022
E2-06 (E4-06)	Motor Leakage Inductance	%	19.5	20.8	20.8	18.8	18.8	20.2	20.2	20.5
E2-10 (E4-10)	Motor Iron Loss for Torque Compensation	W	538	699	699	823	823	852	852	960
E5-01	Motor Code Selection	Hex.	1210	1210	1212	1212	1213	1213	1214	1214
L2-02	Momentary Power Loss Ride-Thru Time	s	2	2	2	2	2	2	2	2
L2-03	Momentary Power Loss Minimum Baseblock Time	s	1	1.1	1.1	1.1	1.1	1.2	1.2	1.3
L2-04	Momentary Power Loss Voltage Recovery Ramp Time	s	0.6	0.6	0.6	0.6	0.6	1	1	1
L3-24	Motor Acceleration Time for Inertia Calculations	s	0.355	0.323	0.323	0.32	0.32	0.387	0.387	0.317
L8-02	Overheat Alarm Level	°C	130	130	130	130	130	130	125	125
L8-35	Installation Method Selection	–	0	0	0	0	0	0	0	0
L8-38	Carrier Frequency Reduction Selection	–	2	2	2	2	2	2	2	2
n1-03	Hunting Prevention Time Constant	ms	10	10	10	10	10	10	10	10
n5-02	Motor Acceleration Time	s	0.355	0.323	0.323	0.32	0.32	0.387	0.387	0.317

<1> This parameter is available in models 4A0930 and 4A1200.

B.18 Defaults by Drive Model and Duty Rating ND/HD

No.	Name	Unit	Default Settings							
			2A0250		2A0312		2A0360		2A0415	
–	Drive Model	–	HD	ND	HD	ND	HD	ND	HD	ND
C6-01	Drive Duty Selection	–	HD	ND	HD	ND	HD	ND	HD	ND
o2-04	Drive Model Selection	Hex.	75		76		77		78	
E2-11 (E4-11)	Motor Rated Power	kW (HP)	22 (75)	30 (100)	30 (100)	37 (125)	37 (125)	45 (150)	45 (150)	55 (175)
b3-04	V/f Gain during Speed Search	%	80	80	80	80	80	80	80	80
b3-06	Output Current 1 during Speed Search	–	0.5	0.7	0.7	0.7	0.7	0.7	0.7	0.7
b3-07 <1>	Output Current 2 during Speed Search (Speed Estimation Type)	–	–	–	–	–	–	–	–	–
b3-26 <1>	Start Speed Search Select	–	–	–	–	–	–	–	–	–
b8-03	Energy Saving Control Filter Time Constant	s	2.00	2.00	2.00	2.00	2.00	2.00	2.00	2.00
b8-04	Energy Saving Coefficient Value	–	31.35	23.1	23.1	20.65	20.65	18.12	18.12	18.12
C5-17 (C5-37)	Motor Inertia	kgm ²	0.49	0.90	0.90	1.10	1.10	1.90	1.90	1.90
C6-02	Carrier Frequency Selection	–	1	7	1	7	1	7	1	7
E2-01 (E4-01)	Motor Rated Current	A	190	260	260	260	260	260	260	260
E2-02 (E4-02)	Motor Rated Slip	Hz	1.43	1.39	1.39	1.39	1.39	1.39	1.39	1.39
E2-03 (E4-03)	Motor No-Load Current	A	45.6	72	72	72	72	72	72	72
E2-05 (E4-05)	Motor Line-to-Line Resistance	Ω	0.022	0.023	0.023	0.023	0.023	0.023	0.023	0.023
E2-06 (E4-06)	Motor Leakage Inductance	%	20.5	20	20	20	20	20	20	20
E2-10 (E4-10)	Motor Iron Loss for Torque Compensation	W	960	1200	1200	1200	1200	1200	1200	1200
E5-01	Motor Code Selection	Hex.	1215	1215	1216	1216	FFFF	FFFF	FFFF	FFFF
L2-02	Momentary Power Loss Ride-Thru Time	s	2	2	2	2	2	2	2	2
L2-03	Momentary Power Loss Minimum Baseblock Time	s	1.3	1.5	1.5	1.5	1.5	1.7	1.7	1.7
L2-04	Momentary Power Loss Voltage Recovery Ramp Time	s	1	1	1	1	1	1	1	1
L3-24	Motor Acceleration Time for Inertia Calculations	s	0.317	0.533	0.533	0.592	0.592	0.646	0.646	0.646
L8-02	Overheat Alarm Level	°C	115	115	120	120	120	120	120	120
L8-35	Installation Method Selection	–	0	0	0	0	0	0	0	0
L8-38	Carrier Frequency Reduction Selection	–	2	2	2	2	2	2	2	2
n1-03	Hunting Prevention Time Constant	ms	10	10	10	10	100	100	100	100
n5-02	Motor Acceleration Time	s	0.317	0.533	0.533	0.592	0.592	0.646	0.646	0.646

<1> This parameter is available in models 4A0930 and 4A1200.

B.18 Defaults by Drive Model and Duty Rating ND/HD

Table B.10 400 V Class Drives Default Settings by Drive Capacity and ND/HD Setting

No.	Name	Unit	Default Settings							
			4A0002		4A0004		4A0005		4A0007	
–	Drive Model	–	HD	ND	HD	ND	HD	ND	HD	ND
C6-01	Drive Duty Selection	–	HD	ND	HD	ND	HD	ND	HD	ND
o2-04	Drive Model Selection	Hex.	92		93		94		95	
E2-11 (E4-11)	Motor rated power	kW (HP)	0.4 (0.75)	0.75 (0.75)	0.75 (2)	1.5 (2)	1.5 (3)	2.2 (3)	2.2 (3)	3.0 (3)
b3-04	V/f Gain during Speed Search	%	100	100	100	100	100	100	100	100
b3-06	Output Current 1 during Speed Search	–	0.5	0.5	0.5	0.5	0.5	0.5	0.5	0.5
b3-07 <1>	Output Current 2 during Speed Search (Speed Estimation Type)	–	–	–	–	–	–	–	–	–
b3-26 <1>	Start Speed Search Select	–	–	–	–	–	–	–	–	–
b8-03	Energy Saving Control Filter Time Constant	s	0.50	0.50	0.50	0.50	0.50	0.50	0.50	0.50
b8-04	Energy Saving Coefficient Value	–	576.4	447.4	447.4	338.8	338.8	313.6	313.6	265.7
C5-17 (C5-37)	Motor Inertia	kgm ²	0.0015	0.0028	0.0028	0.0068	0.0068	0.0088	0.0088	0.0158
C6-02	Carrier Frequency Selection	–	1	7	1	7	1	7	1	7
E2-01 (E4-01)	Motor Rated Current	A	1	1.6	1.6	3.1	3.1	4.2	4.2	5.7
E2-02 (E4-02)	Motor Rated Slip	Hz	2.9	2.6	2.6	2.5	2.5	3	3	2.7
E2-03 (E4-03)	Motor No-Load Current	A	0.6	0.8	0.8	1.4	1.4	1.5	1.5	1.9
E2-05 (E4-05)	Motor Line-to-Line Resistance	Ω	38.198	22.459	22.459	10.1	10.1	6.495	6.495	4.360
E2-06 (E4-06)	Motor Leakage Inductance	%	18.2	14.3	14.3	18.3	18.3	18.7	18.7	19
E2-10 (E4-10)	Motor Iron Loss for Torque Compensation	W	14	26	26	53	53	77	77	105
E5-01	Motor Code Selection	Hex.	1232	1232	1233	1233	1235	1235	1236	1236
L2-02	Momentary Power Loss Ride-Thru Time	s	0.1	0.1	0.2	0.2	0.3	0.3	0.5	0.5
L2-03	Momentary Power Loss Min. Baseblock Time	s	0.2	0.3	0.3	0.4	0.4	0.5	0.5	0.5
L2-04	Momentary Power Loss Voltage Recovery Time	s	0.3	0.3	0.3	0.3	0.3	0.3	0.3	0.3
L3-24	Motor Acceleration Time for Inertia Calculations	s	0.178	0.142	0.142	0.166	0.166	0.145	0.145	0.145
L8-02	Overheat Alarm Level	°C	110	110	110	110	110	110	110	110
L8-35	Installation Method Selection	–	2	2	2	2	2	2	2	2
L8-38	Carrier Frequency Reduction Selection	–	2	2	2	2	2	2	2	2
n1-03	Hunting Prevention Time Constant	ms	10	10	10	10	10	10	10	10
n5-02	Motor Acceleration Time	s	0.178	0.142	0.142	0.166	0.166	0.145	0.145	0.145

<1> This parameter is available in models 4A0930 and 4A1200.

B.18 Defaults by Drive Model and Duty Rating ND/HD

No.	Name	Unit	Default Settings							
			4A0009		4A0011		4A0018		4A0023	
–	Drive Model	–	HD	ND	HD	ND	HD	ND	HD	ND
C6-01	Drive Duty Selection	–	HD	ND	HD	ND	HD	ND	HD	ND
o2-04	Drive Model Selection	Hex.	96		97		99		9A	
E2-11 (E4-11)	Motor Rated Power	kW (HP)	3.0 (5)	3.7 (5)	3.7 (5)	5.5 (7.5)	5.5 (7.5)	7.5 (10)	7.5 (10)	11 (15)
b3-04	V/f Gain during Speed Search	%	100	100	100	100	100	100	100	100
b3-06	Output Current 1 during Speed Search	–	0.5	0.5	0.5	0.5	0.5	0.5	0.5	0.5
b3-07 <1>	Output Current 2 during Speed Search (Speed Estimation Type)	–	–	–	–	–	–	–	–	–
b3-26 <1>	Start Speed Search Select	–	–	–	–	–	–	–	–	–
b8-03	Energy Saving Control Filter Time Constant	s	0.50	0.50	0.50	0.50	0.50	0.50	0.50	0.50
b8-04	Energy Saving Coefficient Value	–	265.7	245.8	245.8	189.5	189.5	145.38	145.38	140.88
C5-17 (C5-37)	Motor Inertia	kgm ²	0.0158	0.0158	0.0158	0.0255	0.026	0.037	0.037	0.053
C6-02	Carrier Frequency Selection	–	1	7	1	7	1	7	1	7
E2-01 (E4-01)	Motor Rated Current	A	5.7	7	7	9.8	9.8	13.3	13.3	19.9
E2-02 (E4-02)	Motor Rated Slip	Hz	2.7	2.7	2.7	1.5	1.5	1.3	1.3	1.7
E2-03 (E4-03)	Motor No-Load Current	A	1.9	2.3	2.3	2.6	2.6	4	4	5.6
E2-05 (E4-05)	Motor Line-to-Line Resistance	Ω	4.360	3.333	3.333	1.595	1.595	1.152	1.152	0.922
E2-06 (E4-06)	Motor Leakage Inductance	%	19	19.3	19.3	18.2	18.2	15.5	15.5	19.6
E2-10 (E4-10)	Motor Iron Loss for Torque Compensation	W	105	130	130	193	193	263	263	385
E5-01	Motor Code Selection	Hex.	FFFF	FFFF	1238	1238	123A	123A	123B	123B
L2-02	Momentary Power Loss Ride-Thru Time	s	0.5	0.5	0.5	0.5	0.8	0.8	1	1
L2-03	Momentary Power Loss Min. Baseblock Time	s	0.5	0.6	0.6	0.7	0.7	0.8	0.8	0.9
L2-04	Momentary Power Loss Voltage Recovery Time	s	0.3	0.3	0.3	0.3	0.3	0.3	0.3	0.3
L3-24	Motor Acceleration Time for Inertia Calculations	s	0.145	0.154	0.154	0.168	0.168	0.175	0.175	0.265
L8-02	Overheat Alarm Level	°C	110	110	110	110	110	110	115	115
L8-35	Installation Method Selection	–	2	2	2	2	2	2	2	2
L8-38	Carrier Frequency Reduction Selection	–	2	2	2	2	2	2	2	2
n1-03	Hunting Prevention Time Constant	ms	10	10	10	10	10	10	10	10
n5-02	Motor Acceleration Time	s	0.145	0.154	0.154	0.168	0.168	0.175	0.175	0.265

<1> This parameter is available in models 4A0930 and 4A1200.

B.18 Defaults by Drive Model and Duty Rating ND/HD

No.	Name	Unit	Default Settings							
			4A0031		4A0038		4A0044		4A0058	
–	Drive Model	–	HD	ND	HD	ND	HD	ND	HD	ND
C6-01	Drive Duty Selection	–	HD	ND	HD	ND	HD	ND	HD	ND
o2-04	Drive Model Selection	Hex.	9C		9D		9E		9F	
E2-11 (E4-11)	Motor Rated Power	kW (HP)	11 (15)	15 (20)	15 (20)	18.5 (25)	18.5 (25-30)	22 (30)	22 (25-30)	30 (40)
b3-04	V/f Gain during Speed Search	%	100	100	100	100	100	100	100	100
b3-06	Output Current 1 during Speed Search	–	0.5	0.5	0.5	0.5	0.5	0.5	0.5	0.5
b3-07 <1>	Output Current 2 during Speed Search (Speed Estimation Type)	–	–	–	–	–	–	–	–	–
b3-26 <1>	Start Speed Search Select	–	–	–	–	–	–	–	–	–
b8-03	Energy Saving Control Filter Time Constant	s	0.50	0.50	0.50	0.50	0.50	0.50	0.50	0.50
b8-04	Energy Saving Coefficient Value	–	140.88	126.26	126.26	115.74	115.74	103.58	103.58	92.54
C5-17 (C5-37)	Motor Inertia	kgm ²	0.053	0.076	0.076	0.138	0.138	0.165	0.165	0.220
C6-02	Carrier Frequency Selection	–	1	7	1	7	1	7	1	7
E2-01 (E4-01)	Motor Rated Current	A	19.9	26.5	26.5	32.9	32.9	38.6	38.6	52.3
E2-02 (E4-02)	Motor Rated Slip	Hz	1.7	1.6	1.6	1.67	1.67	1.7	1.7	1.8
E2-03 (E4-03)	Motor No-Load Current	A	5.6	7.6	7.6	7.8	7.8	9.2	9.2	10.9
E2-05 (E4-05)	Motor Line-to-Line Resistance	Ω	0.922	0.55	0.55	0.403	0.403	0.316	0.316	0.269
E2-06 (E4-06)	Motor Leakage Inductance	%	19.6	17.2	17.2	20.1	20.1	23.5	23.5	20.7
E2-10 (E4-10)	Motor Iron Loss for Torque Compensation	W	385	440	440	508	508	586	586	750
E5-01	Motor Code Selection	Hex.	123D	123D	123E	123E	123F	123F	1240	1240
L2-02	Momentary Power Loss Ride-Thru Time	s	2	2	2	2	2	2	2	2
L2-03	Momentary Power Loss Minimum Baseblock Time	s	0.9	1	1	1	1	1	1	1.1
L2-04	Momentary Power Loss Voltage Recovery Time	s	0.3	0.6	0.6	0.6	0.6	0.6	0.6	0.6
L3-24	Motor Acceleration Time for Inertia Calculations	s	0.265	0.244	0.244	0.317	0.317	0.355	0.355	0.323
L8-02	Overheat Alarm Level	°C	120	120	120	120	115	115	120	120
L8-35	Installation Method Selection	–	2	2	2	2	2	2	0	0
L8-38	Carrier Frequency Reduction Selection	–	2	2	2	2	2	2	2	2
n1-03	Hunting Prevention Time Constant	ms	10	10	10	10	10	10	10	10
n5-02	Motor Acceleration Time	s	0.265	0.244	0.244	0.317	0.317	0.355	0.355	0.323

<1> This parameter is available in models 4A0930 and 4A1200.

B.18 Defaults by Drive Model and Duty Rating ND/HD

No.	Name	Unit	Default Settings							
			4A0072		4A0088		4A0103		4A0139	
–	Drive Model	–	HD	ND	HD	ND	HD	ND	HD	ND
C6-01	Drive Duty Selection	–	HD	ND	HD	ND	HD	ND	HD	ND
o2-04	Drive Model Selection	Hex.	A1		A2		A3		A4	
E2-11 (E4-11)	Motor rated power	kW (HP)	30 (40)	37 (50)	37 (50-60)	45 (60)	45 (50-60)	55 (75)	55 (75)	75 (100)
b3-04	V/f Gain during Speed Search	%	100	100	100	100	100	80	80	60
b3-06	Output Current 1 during Speed Search	–	0.5	0.5	0.5	0.5	0.5	0.5	0.5	0.7
b3-07 <1>	Output Current 2 during Speed Search (Speed Estimation Type)	–	–	–	–	–	–	–	–	–
b3-26 <1>	Start Speed Search Select	–	–	–	–	–	–	–	–	–
b8-03	Energy Saving Control Filter Time Constant	s	0.50	0.50	0.50	0.50	0.50	2.00	2.00	2.00
b8-04	Energy Saving Coefficient Value	–	92.54	76.32	76.32	71.56	71.56	67.2	67.2	46.2
C5-17 (C5-37)	Motor Inertia	kgm ²	0.220	0.273	0.273	0.333	0.333	0.490	0.490	0.90
C6-02	Carrier Frequency Selection	–	1	7	1	7	1	7	1	7
E2-01 (E4-01)	Motor Rated Current	A	52.3	65.6	65.6	79.7	79.7	95	95	130
E2-02 (E4-02)	Motor Rated Slip	Hz	1.8	1.33	1.33	1.6	1.6	1.46	1.46	1.39
E2-03 (E4-03)	Motor No-Load Current	A	10.9	19.1	19.1	22	22	24	24	36
E2-05 (E4-05)	Motor Line-to-Line Resistance	Ω	0.269	0.155	0.155	0.122	0.122	0.088	0.088	0.092
E2-06 (E4-06)	Motor Leakage Inductance	%	20.7	18.8	18.8	19.9	19.9	20	20	20
E2-10 (E4-10)	Motor Iron Loss for Torque Compensation	W	750	925	925	1125	1125	1260	1260	1600
E5-01	Motor Code Selection	Hex.	1242	1242	1243	1243	1244	1244	1245	1245
L2-02	Momentary Power Loss Ride-Thru Time	s	2	2	2	2	2	2	2	2
L2-03	Momentary Power Loss Min. Basebl. Time	s	1.1	1.1	1.1	1.2	1.2	1.2	1.2	1.3
L2-04	Momentary Power Loss Volt. Recov. Time	s	0.6	0.6	0.6	0.6	0.6	1	1	1
L3-24	Motor Acceleration Time for Inertia Calculations	s	0.323	0.32	0.32	0.387	0.387	0.317	0.317	0.533
L8-02	Overheat Alarm Level	°C	120	120	110	110	120	120	130	130
L8-35	Installation Method Selection	–	0	0	0	0	0	0	0	0
L8-38	Carrier Frequency Reduction Selection	–	2	2	2	2	2	2	2	2
n1-03	Hunting Prevention Time Constant	ms	10	10	10	10	10	10	30	30
n5-02	Motor Acceleration Time	s	0.323	0.32	0.32	0.387	0.387	0.317	0.317	0.533

<1> This parameter is available in models 4A0930 and 4A1200.

B.18 Defaults by Drive Model and Duty Rating ND/HD

No.	Name	Unit	Default Settings							
			4A0165		4A0208		4A0250		4A0296	
–	Drive Model	–	HD	ND	HD	ND	HD	ND	HD	ND
C6-01	Drive Duty Selection	–	HD	ND	HD	ND	HD	ND	HD	ND
o2-04	Drive Model Selection	Hex.	A5		A6		A7		A8	
E2-11 (E4-11)	Motor rated power	kW (HP)	75 (100)	90 (125)	90 (125-150)	110 (150)	110 (150)	132 (200)	132 (200)	160 (250)
b3-04	V/f Gain during Speed Search	%	60	60	60	60	60	60	60	60
b3-06	Output Current 1 during Speed Search	–	0.7	0.7	0.7	0.7	0.7	0.7	0.7	0.7
b3-07 <1>	Output Current 2 during Speed Search (Speed Estimation Type)	–	–	–	–	–	–	–	–	–
b3-26 <1>	Start Speed Search Select	–	–	–	–	–	–	–	–	–
b8-03	Energy Saving Control Filter Time Constant	s	2.00	2.00	2.00	2.00	2.00	2.00	2.00	2.00
b8-04	Energy Saving Coefficient Value	–	46.2	38.91	38.91	36.23	36.23	32.79	32.79	30.13
C5-17 (C5-37)	Motor Inertia	kgm ²	0.90	1.10	1.10	1.90	1.90	2.10	2.10	3.30
C6-02	Carrier Frequency Selection	–	1	7	1	7	1	7	1	7
E2-01 (E4-01)	Motor Rated Current	A	130	156	156	190	190	223	223	270
E2-02 (E4-02)	Motor Rated Slip	Hz	1.39	1.4	1.4	1.4	1.4	1.38	1.38	1.35
E2-03 (E4-03)	Motor No-Load Current	A	36	40	40	49	49	58	58	70
E2-05 (E4-05)	Motor Line-to-Line Resistance	Ω	0.092	0.056	0.056	0.046	0.046	0.035	0.035	0.029
E2-06 (E4-06)	Motor Leakage Inductance	%	20	20	20	20	20	20	20	20
E2-10 (E4-10)	Motor Iron Loss for Torque Compensation	W	1600	1760	1760	2150	2150	2350	2350	2850
E5-01	Motor Code Selection	Hex.	1246	1246	1247	1247	1248	1248	1249	1249
L2-02	Momentary Power Loss Ride-Thru Time	s	2	2	2	2	2	2	2	2
L2-03	Momentary Power Loss Min. Basebl. Time	s	1.3	1.5	1.5	1.7	1.7	1.7	1.7	1.8
L2-04	Momentary Power Loss Volt. Recov. Time	s	1	1	1	1	1	1	1	1
L3-24	Motor Acceleration Time for Inertia Calculations	s	0.533	0.592	0.592	0.646	0.646	0.673	0.673	0.777
L8-02	Overheat Alarm Level	°C	130	130	120	120	120	120	125	125
L8-35	Installation Method Selection	–	0	0	0	0	0	0	0	0
L8-38	Carrier Frequency Reduction Selection	–	2	2	2	2	2	2	2	2
n1-03	Hunting Prevention Time Constant	ms	30	30	30	30	30	30	30	30
n5-02	Motor Acceleration Time	s	0.533	0.592	0.592	0.646	0.646	0.673	0.673	0.777

<1> This parameter is available in models 4A0930 and 4A1200.

B.18 Defaults by Drive Model and Duty Rating ND/HD

No.	Name	Unit	Default Settings					
			4A0362		4A0414		4A0515	
–	Drive Model	–	HD	ND	HD	ND	HD	ND
C6-01	Drive Duty Selection	–	HD	ND	HD	ND	HD	ND
o2-04	Drive Model Selection	Hex.	A9		AA		AC	
E2-11 (E4-11)	Motor rated power	kW (HP)	160 (250)	185 (300)	185 (300)	220 (350)	220 (350)	250 (400-450)
b3-04	V/f Gain during Speed Search	%	60	60	60	60	60	60
b3-06	Output Current 1 during Speed Search	–	0.7	0.7	0.7	0.7	0.7	0.7
b3-07 <1>	Output Current 2 during Speed Search (Speed Estimation Type)	–	–	–	–	–	–	–
b3-26 <1>	Start Speed Search Select	–	–	–	–	–	–	–
b8-03	Energy Saving Control Filter Time Constant	s	2.00	2.00	2.00	2.00	2.00	2.00
b8-04	Energy Saving Coefficient Value	–	30.13	30.57	30.57	27.13	27.13	21.76
C5-17 (C5-37)	Motor Inertia	kgm ²	3.30	3.60	3.60	4.10	4.10	6.50
C6-02	Carrier Frequency Selection	–	1	7	1	7	1	7
E2-01 (E4-01)	Motor Rated Current	A	270	310	310	370	370	500
E2-02 (E4-02)	Motor Rated Slip	Hz	1.35	1.3	1.3	1.3	1.3	1.25
E2-03 (E4-03)	Motor No-Load Current	A	70	81	81	96	96	130
E2-05 (E4-05)	Motor Line-to-Line Resistance	Ω	0.029	0.025	0.025	0.02	0.02	0.014
E2-06 (E4-06)	Motor Leakage Inductance	%	20	20	20	20	20	20
E2-10 (E4-10)	Motor Iron Loss for Torque Compensation	W	2850	3200	3200	3700	3700	4700
E5-01	Motor Code Selection	Hex.	124A	124A	FFFF	FFFF	FFFF	FFFF
L2-02	Momentary Power Loss Ride-Thru Time	s	2	2	2	2	2	2
L2-03	Momentary Power Loss Min. Basebl. Time	s	1.8	1.9	1.9	2	2	2.1
L2-04	Momentary Power Loss Volt. Recov. Time	s	1	1	1	1	1	1
L3-24	Motor Acceleration Time for Inertia Calculations	s	0.777	0.864	0.864	0.91	0.91	1.392
L8-02	Overheat Alarm Level	°C	130	130	140	140	140	140
L8-35	Installation Method Selection	–	0	0	0	0	0	0
L8-38	Carrier Frequency Reduction Selection	–	2	2	2	2	2	2
n1-03	Hunting Prevention Time Constant	ms	30	30	100	100	100	100
n5-02	Motor Acceleration Time	s	0.777	0.864	0.864	0.91	0.91	1.392

<1> This parameter is available in models 4A0930 and 4A1200.

B.18 Defaults by Drive Model and Duty Rating ND/HD

No.	Name	Unit	Default Settings					
			4A0675		4A0930		4A1200	
–	Drive Model	–	HD	ND	HD	ND	HD	ND
C6-01	Drive Duty Selection	–	HD	ND	HD	ND	HD	ND
o2-04	Drive Model Selection	Hex.	AE		B0		B2	
E2-11 (E4-11)	Motor rated power	kW (HP)	315 (400 -450 -500)	355 (500 -550)	450 (650)	500 (750)	560 (900)	630 (1000)
b3-04	V/f Gain during Speed Search	%	60	60	60	60	60	60
b3-06	Output Current 1 during Speed Search	–	0.7	0.7	0.7	0.7	0.7	0.7
b3-07 <1>	Output Current 2 during Speed Search (Speed Estimation Type)	–	–	–	3.0	2.0	3.0	2.0
b3-26 <1>	Start Speed Search Select	–	–	–	1000	1000	1000	1000
b8-03	Energy Saving Control Filter Time Constant	s	2.00	2.00	2.00	2.00	2.00	2.00
b8-04	Energy Saving Coefficient Value	–	21.76	23.84	21.4	20.26	18.12	17.06
C5-17 (C5-37)	Motor Inertia	kgm ²	11.00	12.00	13.00	14.00	18.00	18.00
C6-02	Carrier Frequency Selection	–	1	7	1	7	1	7
E2-01 (E4-01)	Motor Rated Current	A	500	650	800	900	1090	1200
E2-02 (E4-02)	Motor Rated Slip	Hz	1.25	1	1	0.9	0.8	0.7
E2-03 (E4-03)	Motor No-Load Current	A	130	130	160	180	218	240
E2-05 (E4-05)	Motor Line-to-Line Resistance	Ω	0.014	0.012	0.01	0.009	0.007	0.006
E2-06 (E4-06)	Motor Leakage Inductance	%	20	20	20	20	20	20
E2-10 (E4-10)	Motor Iron Loss for Torque Compensation	W	4700	5560	7050	7833	9870	11123
E5-01	Motor Code Selection	Hex.	FFFF	FFFF	FFFF	FFFF	FFFF	FFFF
L2-02	Momentary Power Loss Ride-Thru Time	s	2	2	2	2	2	2
L2-03	Momentary Power Loss Min. Basebl. Time	s	2.1	2.3	2.8	3.1	4	4.6
L2-04	Momentary Power Loss Volt. Recov. Time	s	1	1	2.6	3	3.8	4.5
L3-24	Motor Acceleration Time for Inertia Calculations	s	1.392	1.667	2	2.222	2.857	3.333
L8-02	Overheat Alarm Level	°C	140	140	140	140	140	140
L8-35	Installation Method Selection	–	0	0	0	0	0	0
L8-38	Carrier Frequency Reduction Selection	–	2	2	2	2	2	2
n1-03	Hunting Prevention Time Constant	ms	100	100	100	100	100	100
n5-02	Motor Acceleration Time	s	1.392	1.667	2	2.222	2.857	3.333

<1> This parameter is available in models 4A0930 and 4A1200.

Table B.11 600 V Class Drives Default Settings by Drive Model and ND/HD Setting

No.	Name	Unit	Default Settings									
			5A0003		5A0004		5A0006		5A0009		5A0011	
–	Drive Model	–	HD	ND	HD	ND	HD	ND	HD	ND	HD	ND
C6-01	Drive Duty Selection	–	0	1	0	1	0	1	0	1	0	1
o2-04	Drive Model Selection	Hex	C3		C4		C5		C7		C9	
E2-11 (E4-11)	Motor Rated Power	kW (HP)	0.75 (1)	1.5 (2)	1.5 (2)	2.2 (3)	2.2 (3)	3.7 (5)	3.7 (5)	5.5 (7.5)	5.5 (7.5)	7.5 (10)
b3-04	V/f Gain during Speed Search	%	100	100	100	100	100	100	100	100	100	100
b3-06	Output Current 1 during Speed Search	–	0.5	0.5	0.5	0.5	0.5	0.5	0.5	0.5	0.5	0.5
b3-07 <1>	Output Current 2 during Speed Search (Speed Estimation Type)	–	–	–	–	–	–	–	–	–	–	–
b3-26 <1>	Start Speed Search Select	–	–	–	–	–	–	–	–	–	–	–
b8-03	Energy Saving Control Filter Time Constant	s	0.50	0.50	0.50	0.50	0.50	0.50	0.50	0.50	0.50	0.50
b8-04	Energy Saving Coefficient Value	–	541.9	494.4	494.4	415.3	415.3	320.2	320.2	239.95	239.95	199.86
C5-17 (C5-37)	Motor Inertia	kgm ²	0.0028	0.0068	0.0068	0.0088	0.0088	0.0158	0.0158	0.0255	0.026	0.037
C6-02	Carrier Frequency Selection	–	1	7	1	7	1	7	1	7	1	7
E2-01 (E4-01)	Motor Rated Current	A	1.7	2.7	2.7	3.9	3.9	6.1	6.1	9	9	11
E2-02 (E4-02)	Motor Rated Slip	Hz	2.5	2.5	2.5	3.0	3.0	2.7	2.7	1.5	1.5	1.3
E2-03 (E4-03)	Motor No-Load Current	A	0.8	0.8	0.8	1.2	1.2	1.8	1.8	2.7	2.7	3.3
E2-05 (E4-05)	Motor Line-to-Line Resistance	Ω	21.9	13.72	13.72	8.825	8.825	4.936	4.936	2.601	2.601	1.446
E2-06 (E4-06)	Motor Leakage Inductance	%	18.3	18.3	18.3	18.7	18.7	19.3	19.3	18.2	18.2	15.5
E2-10 (E4-10)	Motor Iron Loss for Torque Compensation	W	53	53	53	77	77	130	130	193	193	263
L2-02	Momentary Power Loss Ride-Thru Time	s	0.2	0.2	0.3	0.3	0.5	0.5	0.5	0.5	0.8	0.8
L2-03	Momentary Power Loss Minimum Baseblock Time	s	0.5	0.5	0.5	0.5	0.5	0.8	0.8	0.8	0.8	1
L2-04	Momentary Power Loss Voltage Recovery Time	s	0.5	0.5	0.5	0.5	0.5	0.6	0.6	0.7	0.7	0.8
L3-24	Motor Acceleration Time for Inertia Calculations	s	0.142	0.166	0.166	0.145	0.145	0.154	0.154	0.168	0.168	0.175
L8-02	Overheat Alarm Level	°C	110	110	110	110	110	110	110	110	115	115
L8-35	Installation Method Selection	–	2	2	2	2	2	2	2	2	2	2
L8-38	Carrier Frequency Reduction Selection	–	2	2	2	2	2	2	2	2	2	2
n1-03	Hunting Prevention Time Constant	ms	10	10	10	10	10	10	10	10	10	10
n5-02	Motor Acceleration Time	s	0.142	0.166	0.166	0.145	0.145	0.154	0.154	0.168	0.168	0.175

<1> This parameter is available in models 4A0930 and 4A1200.

B.18 Defaults by Drive Model and Duty Rating ND/HD

No.	Name	Unit	Default Settings							
			5A0017		5A0022		5A0027		5A0032	
–	Drive Model	–	HD	ND	HD	ND	HD	ND	HD	ND
C6-01	Drive Duty Selection	–	0	1	0	1	0	1	0	1
o2-04	Drive Model Selection	Hex.	CA		CC		CD		CE	
E2-11 (E4-11)	Motor Rated Power	kW (HP)	7.5 (10)	11 (15)	11 (15)	15 (20)	15 (20)	18.5 (25)	18.5 (25)	22 (30)
b3-04	V/f Gain during Speed Search	%	100	100	100	100	100	100	100	100
b3-06	Output Current 1 during Speed Search	–	0.5	0.5	0.5	0.5	0.5	0.5	0.5	0.5
b3-07 <1>	Output Current 2 during Speed Search (Speed Estimation Type)	–	–	–	–	–	–	–	–	–
b3-26 <1>	Start Speed Search Select	–	–	–	–	–	–	–	–	–
b8-03	Energy Saving Control Filter Time Constant	s	0.5	0.5	0.5	0.5	0.5	0.5	0.5	0.5
b8-04	Energy Saving Coefficient Value	–	200	172	172	154	154	140	140	129
C5-17 (C5-37)	Motor Inertia	kgm ²	0.037	0.053	0.053	0.076	0.076	0.138	0.138	0.165
C6-02	Carrier Frequency Selection	–	1	7	1	7	1	7	1	7
E2-01 (E4-01)	Motor Rated Current	A	11	17	17	22	22	27	27	32
E2-02 (E4-02)	Motor Rated Slip	Hz	1.3	1.7	1.7	1.6	1.6	1.67	1.67	1.7
E2-03 (E4-03)	Motor No-Load Current	A	3.3	5.1	5.1	6.6	6.6	8.1	8.1	9.6
E2-05 (E4-05)	Motor Line-to-Line Resistance	Ω	1.45	1.17	1.17	0.9	0.9	0.66	0.66	0.52
E2-06 (E4-06)	Motor Leakage Inductance	%	15.5	19.6	19.6	17.2	17.2	20.1	20.1	23.5
E2-10 (E4-10)	Motor Iron Loss for Torque Compensation	W	263	385	385	440	440	508	508	586
L2-02	Momentary Power Loss Ride-Thru Time	s	1	1	2	2	2	2	2	2
L2-03	Momentary Power Loss Minimum Baseblock Time	s	1	1	1	1.2	1.2	1.2	1.2	1.2
L2-04	Momentary Power Loss Voltage Recovery Time	s	0.8	0.9	0.9	1	1	1	1	1
L3-24	Motor Acceleration Time for Inertia Calculations	s	0.18	0.27	0.27	0.24	0.24	0.32	0.32	0.36
L8-02	Overheat Alarm Level	°C	120	120	120	120	115	115	115	115
L8-35	Installation Method Selection	–	2	2	2	2	2	2	2	2
L8-38	Carrier Frequency Reduction Selection	–	2	2	2	2	2	2	2	2
n1-03	Hunting Prevention Time Constant	ms	10	10	10	10	10	10	10	10
n5-02	Motor Acceleration Time	s	0.18	0.27	0.27	0.24	0.24	0.32	0.32	0.36

<1> This parameter is available in models 4A0930 and 4A1200.

B.18 Defaults by Drive Model and Duty Rating ND/HD

No.	Name	Unit	Default Settings					
			5A0041		5A0052		5A0062	
–	Drive Model	–	HD	ND	HD	ND	HD	ND
C6-01	Drive Duty Selection	–	0	1	0	1	0	1
o2-04	Drive Model Selection	Hex.	CF		D1		D2	
E2-11 (E4-11)	Motor Rated Power	kW (HP)	22 (25-30)	30 (40)	30 (40)	37 (50)	37 (50-60)	45 (60)
b3-04	V/f Gain during Speed Search	%	100	80	80	80	80	80
b3-06	Output Current 1 during Speed Search	–	0.5	0.5	0.5	0.5	0.5	0.5
b3-07 <1>	Output Current 2 during Speed Search (Speed Estimation Type)	–	–	–	–	–	–	–
b3-26 <1>	Start Speed Search Select	–	–	–	–	–	–	–
b8-03	Energy Saving Control Filter Time Constant	s	0.5	0.5	0.5	0.5	0.5	0.5
b8-04	Energy Saving Coefficient Value	–	128.65	115.57	115.57	97.01	97.01	90.07
C5-17 (C5-37)	Motor Inertia	kgm ²	0.165	0.220	0.220	0.273	0.273	0.333
C6-02	Carrier Frequency Selection	–	1	7	1	7	1	7
E2-01 (E4-01)	Motor Rated Current	A	32	41	41	52	52	62
E2-02 (E4-02)	Motor Rated Slip	Hz	1.7	1.8	1.8	1.33	1.33	1.6
E2-03 (E4-03)	Motor No-Load Current	A	9.6	12.3	12.3	15.6	15.6	18.8
E2-05 (E4-05)	Motor Line-to-Line Resistance	Ω	0.516	0.438	0.438	0.267	0.267	0.21
E2-06 (E4-06)	Motor Leakage Inductance	%	23.5	20.7	20.7	18.8	18.8	19.9
E2-10 (E4-10)	Motor Iron Loss for Torque Compensation	W	586	750	750	925	925	1125
L2-02	Momentary Power Loss Ride-Thru Time	s	2	2	2	2	2	2
L2-03	Momentary Power Loss Minimum Baseblock Time	s	1.2	1.2	1.2	1.2	1.2	1.5
L2-04	Momentary Power Loss Voltage Recovery Time	s	1	1.1	1.1	1.2	1.2	1.3
L3-24	Motor Acceleration Time for Inertia Calculations	s	0.355	0.323	0.323	0.32	0.32	0.387
L8-02	Overheat Alarm Level	°C	110	110	110	110	110	110
L8-35	Installation Method Selection	–	2	2	2	2	2	2
L8-38	Carrier Frequency Reduction Selection	–	2	2	2	2	2	2
n1-03	Hunting Prevention Time Constant	ms	10	10	10	10	10	10
n5-02	Motor Acceleration Time	s	0.355	0.323	0.323	0.32	0.32	0.387

<1> This parameter is available in models 4A0930 and 4A1200.

B.18 Defaults by Drive Model and Duty Rating ND/HD

No.	Name	Unit	Default Settings			
			5A0077		5A0099	
–	Drive Model	–	HD	ND	HD	ND
C6-01	Drive Duty Selection	–	0	1	0	1
o2-04	Drive Model Selection	Hex.	D3		D4	
E2-11 (E4-11)	Motor Rated Power	kW (HP)	45 (50-60)	55 (75)	55 (75)	75 (100)
b3-04	V/f Gain during Speed Search	%	80	80	80	80
b3-06	Output Current 1 during Speed Search	–	0.5	0.5	0.5	0.5
b3-07 <1>	Output Current 2 during Speed Search (Speed Estimation Type)	–	–	–	–	–
b3-26 <1>	Start Speed Search Select	–	–	–	–	–
b8-03	Energy Saving Control Filter Time Constant	s	0.5	2	2	2
b8-04	Energy Saving Coefficient Value	–	90.07	80.87	80.87	70.07
C5-17 (C5-37)	Motor Inertia	kgm ²	0.333	0.490	0.49	0.90
C6-02	Carrier Frequency Selection	–	1	7	1	7
E2-01 (E4-01)	Motor Rated Current	A	62	77	77	99
E2-02 (E4-02)	Motor Rated Slip	Hz	1.6	1.46	1.46	1.39
E2-03 (E4-03)	Motor No-Load Current	A	18.8	23.1	23.1	29.7
E2-05 (E4-05)	Motor Line-to-Line Resistance	Ω	0.21	0.15	0.15	0.099
E2-06 (E4-06)	Motor Leakage Inductance	%	19.9	20	20	20
E2-10 (E4-10)	Motor Iron Loss for Torque Compensation	W	1125	1260	1260	1600
L2-02	Momentary Power Loss Ride-Thru Time	s	2	2	2	2
L2-03	Momentary Power Loss Minimum Baseblock Time	s	1.5	1.8	1.8	1.8
L2-04	Momentary Power Loss Voltage Recovery Time	s	1.3	1.5	1.5	1.6
L3-24	Motor Acceleration Time for Inertia Calculations	s	0.387	0.317	0.317	0.533
L8-02	Overheat Alarm Level	°C	110	110	110	110
L8-35	Installation Method Selection	–	2	2	2	2
L8-38	Carrier Frequency Reduction Selection	–	2	2	2	2
n1-03	Hunting Prevention Time Constant	ms	10	10	30	30
n5-02	Motor Acceleration Time	s	0.387	0.317	0.317	0.533

<1> This parameter is available in models 4A0930 and 4A1200.

B.18 Defaults by Drive Model and Duty Rating ND/HD

No.	Name	Unit	Default Settings							
			5A0125		5A0145		5A0192		5A0242	
–	Drive Model	–	HD	ND	HD	ND	HD	ND	HD	ND
C6-01	Drive Duty Selection	–	0	1	0	1	0	1	0	1
o2-04	Drive Model Selection	Hex.	D5		D6		D7		D9	
E2-11 (E4-11)	Motor Rated Power	kW (HP)	75 (100)	90 (125)	90 (125)	110 (150)	110 (150)	160 (200)	160 (200)	185 (250)
b3-04	V/f Gain during Speed Search	%	80	80	80	80	80	80	80	80
b3-06	Output Current 1 during Speed Search	–	0.5	0.5	0.5	0.5	0.5	0.5	0.5	0.5
b3-07 <1>	Output Current 2 during Speed Search (Speed Estimation Type)	–	–	–	–	–	–	–	–	–
b3-26 <1>	Start Speed Search Select	–	–	–	–	–	–	–	–	–
b8-03	Energy Saving Control Filter Time Constant	s	2.00	2.00	2.00	2.00	2.00	2.00	2.00	2.00
b8-04	Energy Saving Coefficient Value	–	70.07	61.50	61.50	58.67	58.67	49.90	49.90	42.90
C5-17 (C5-37)	Motor Inertia	kgm ²	0.90	1.10	1.10	1.90	1.90	2.10	3.30	4.10
C6-02	Carrier Frequency Selection	–	1	7	1	7	1	7	1	7
E2-01 (E4-01)	Motor Rated Current	A	99	125	130	145	172	192	200	242
E2-02 (E4-02)	Motor Rated Slip	Hz	1.39	1.39	1.39	1.40	1.40	1.35	1.35	1.35
E2-03 (E4-03)	Motor No-Load Current	A	29.7	37.5	37.5	43.2	43.2	57.6	57.6	57.6
E2-05 (E4-05)	Motor Line-to-Line Resistance	Ω	0.099	0.079	0.079	0.060	0.060	0.037	0.037	0.037
E2-06 (E4-06)	Motor Leakage Inductance	%	20.0	20.0	20.0	20.0	20.0	20.0	20.0	20.0
E2-10 (E4-10)	Motor Iron Loss for Torque Compensation	W	1600	2150	2150	2150	2150	2850	2850	2850
L2-02	Momentary Power Loss Ride-Thru Time	s	2.0	2.0	2.0	2.0	2.0	2.0	2.0	2.0
L2-03	Momentary Power Loss Minimum Baseblock Time	s	1.8	2.0	2.0	2.0	2.0	2.0	2.0	2.0
L2-04	Momentary Power Loss Voltage Recovery Time	s	1.6	1.7	1.7	1.8	1.8	2.0	2.0	2.0
L3-24	Motor Acceleration Time for Inertia Calculations	s	0.533	0.592	0.592	0.646	0.646	0.673	0.777	0.864
L8-02	Overheat Alarm Level	°C	110	110	110	110	110	110	110	110
L8-35	Installation Method Selection	–	0	0	0	0	0	0	0	0
L8-38	Carrier Frequency Reduction Selection	–	2	2	2	2	2	2	2	2
n1-03	Hunting Prevention Time Constant	ms	30	30	30	30	30	30	30	30
n5-02	Motor Acceleration Time	s	0.533	0.592	0.592	0.646	0.646	0.673	0.777	0.864

<1> This parameter is available in models 4A0930 and 4A1200.

B.19 Parameters Changed by Motor Code Selection

The following tables show parameters and default settings that change with the motor code selection E5-01 when Open Loop Vector for PM motors is used.

◆ Yaskawa SMRA Series SPM Motor

Table B.12 200 V, 1800 r/min Type Yaskawa SMRA Series SPM Motor Settings

No.	Name	Unit	Default Settings				
E5-01	Motor Code Selection	–	0002	0003	0005	0006	0008
	Voltage Class	V	200	200	200	200	200
	Rated Power	kW	0.4	0.75	1.5	2.2	3.7
	Rated Speed	r/min	1800	1800	1800	1800	1800
E5-02	Motor Rated Power	kW	0.4	0.75	1.5	2.2	3.7
E5-03	Motor Rated Current	A	2.1	4.0	6.9	10.8	17.4
E5-04	Number of Motor Poles	–	8	8	8	8	8
E5-05	Motor Stator Resistance (r1)	Ω	2.47	1.02	0.679	0.291	0.169
E5-06	Motor d-Axis Inductance (Ld)	mH	12.7	4.8	3.9	3.6	2.5
E5-07	Motor q-Axis Inductance (Lq)	mH	12.7	4.8	3.9	3.6	2.5
E5-09	Motor Induction Voltage Constant 1 (Ke)	mVs /rad	0	0	0	0	0
E5-24	Motor Induction Voltage Constant 2 (Ke)	mV/ (r/min)	62.0	64.1	73.4	69.6	72.2
E1-04	Maximum Output Frequency	Hz	120	120	120	120	120
E1-05	Maximum Voltage	V	200.0	200.0	200.0	200.0	200.0
E1-06	Base Frequency	Hz	120	120	120	120	120
E1-09	Minimum Output Frequency	Hz	6	6	6	6	6
C5-17	Motor Inertia	kgm ²	0.0007	0.0014	0.0021	0.0032	0.0046
L3-24 <1>	Motor Acceleration Time for Inertia Calculations	s	0.064	0.066	0.049	0.051	0.044
n5-02	Motor Acceleration Time	s	0.064	0.066	0.049	0.051	0.044
n8-49	d-Axis Current for High Efficiency Control (OLV/PM)	%	0	0	0	0	0

<1> Default setting value varies depending on parameter o2-04, Drive Model Selection.

Table B.13 200 V, 3600 r/min Type Yaskawa SMRA Series SPM Motor Settings

No.	Name	Unit	Default Settings			
E5-01	Motor Code Selection	–	0103	0105	0106	0108
	Voltage Class	V	200	200	200	200
	Rated Power	kW	0.75	1.5	2.2	3.7
	Rated Speed	r/min	3600	3600	3600	3600
E5-02	Motor Rated Power	kW	0.75	1.5	2.2	3.7
E5-03	Motor Rated Current	A	4.1	8.0	10.5	16.5
E5-04	Number of Motor Poles	–	8	8	8	8
E5-05	Motor Stator Resistance (r1)	Ω	0.538	0.20	0.15	0.097
E5-06	Motor d-Axis Inductance (Ld)	mH	3.2	1.3	1.1	1.1
E5-07	Motor q-Axis Inductance (Lq)	mH	3.2	1.3	1.1	1.1
E5-09	Motor Induction Voltage Constant 1 (Ke)	mVs /rad	0	0	0	0
E5-24	Motor Induction Voltage Constant 2 (Ke)	mV/ (r/min)	32.4	32.7	36.7	39.7
E1-04	Maximum Output Frequency	Hz	240	240	240	240
E1-05	Maximum Voltage	V	200.0	200.0	200.0	200.0
E1-06	Base Frequency	Hz	240	240	240	240
E1-09	Minimum Output Frequency	Hz	12	12	12	12
C5-17	Motor Inertia	kgm ²	0.0007	0.0014	0.0021	0.0032

B.19 Parameters Changed by Motor Code Selection

No.	Name	Unit	Default Settings			
L3-24 <1>	Motor Acceleration Time for Inertia Calculations	s	0.137	0.132	0.132	0.122
n5-02	Motor Acceleration Time	s	0.137	0.132	0.132	0.122
n8-49	d-Axis Current for High Efficiency Control (OLV/PM)	%	0	0	0	0

<1> Default setting value varies depending on parameter o2-04, Drive Model Selection.

◆ Yaskawa SSR1 Series IPM Motor (For Derated Torque)

Table B.14 200 V, 1750 r/min Type Yaskawa SSR1 Series IPM Motor

No.	Name	Unit	Default Settings							
E5-01	Motor Code Selection	–	1202	1203	1205	1206	1208	120A	120B	120D
	Voltage Class	V	200	200	200	200	200	200	200	200
	Rated Power	kW	0.4	0.75	1.5	2.2	3.7	5.5	7.5	11
	Rated Speed	r/min	1750	1750	1750	1750	1750	1750	1750	1750
E5-02	Motor Rated Power	kW	0.4	0.75	1.5	2.2	3.7	5.5	7.5	11.0
E5-03	Motor Rated Current	A	1.77	3.13	5.73	8.44	13.96	20.63	28.13	41.4
E5-04	Number of Motor Poles	–	6	6	6	6	6	6	6	6
E5-05	Motor Stator Resistance (r1)	Ω	8.233	2.284	1.470	0.827	0.455	0.246	0.198	0.094
E5-06	Motor d-Axis Inductance (Ld)	mH	54.84	23.02	17.22	8.61	7.20	4.86	4.15	3.40
E5-07	Motor q-Axis Inductance (Lq)	mH	64.10	29.89	20.41	13.50	10.02	7.43	5.91	3.91
E5-09	Motor Induction Voltage Constant 1 (Ke)	mVs/rad	223.7	220.3	240.8	238.0	238.7	239.6	258.2	239.3
E5-24	Motor Induction Voltage Constant 2 (Ke)	mV/(r/min)	0.0	0.0	0.0	0.0	0.0	0.0	0.0	0.0
E1-04	Maximum Output Frequency	Hz	87.5	87.5	87.5	87.5	87.5	87.5	87.5	87.5
E1-05	Maximum Voltage	V	190.0	190.0	190.0	190.0	190.0	190.0	190.0	190.0
E1-06	Base Frequency	Hz	87.5	87.5	87.5	87.5	87.5	87.5	87.5	87.5
E1-09	Minimum Output Frequency	Hz	4.4	4.4	4.4	4.4	4.4	4.4	4.4	4.4
C5-17	Motor Inertia	kgm ²	0.0011	0.0017	0.0023	0.0043	0.0083	0.014	0.017	0.027
L3-24 <1>	Motor Acceleration Time for Inertia Calculations	s	0.092	0.076	0.052	0.066	0.075	0.083	0.077	0.084
n5-02	Motor Acceleration Time	s	0.092	0.076	0.052	0.066	0.075	0.083	0.077	0.084
n8-49	d-Axis Current for High Efficiency Control (OLV/PM)	%	-7.6	-11.5	-9.1	-19.0	-18.7	-23.4	-18.5	-10.9

<1> Default setting value varies depending on parameter o2-04, Drive Model Selection.

Table B.15 200 V, 1750 r/min Type Yaskawa SSR1 Series IPM Motor

No.	Name	Unit	Default Settings							
E5-01	Motor Code Selection	–	120E	120F	1210	1212	1213	1214	1215	1216
	Voltage Class	V	200	200	200	200	200	200	200	200
	Rated Power	kW	15	18	22	30	37	45	55	75
	Rated Speed	r/min	1750	1750	1750	1750	1750	1750	1750	1750
E5-02	Motor Rated Power	kW	15.0	18.00	22.00	30.00	37.00	45.00	55.00	75.00
E5-03	Motor Rated Current	A	55.4	68.2	80.6	105.2	131.3	153.1	185.4	257.3
E5-04	Number of Motor Poles	–	6	6	6	6	6	6	6	6
E5-05	Motor Stator Resistance (r1)	Ω	0.066	0.051	0.037	0.030	0.020	0.014	0.012	0.006
E5-06	Motor d-Axis Inductance (Ld)	mH	2.45	2.18	1.71	1.35	0.99	0.83	0.79	0.44
E5-07	Motor q-Axis Inductance (Lq)	mH	3.11	2.55	2.05	1.82	1.28	1.01	0.97	0.56

B.19 Parameters Changed by Motor Code Selection

No.	Name	Unit	Default Settings							
E5-09	Motor Induction Voltage Constant 1 (Ke)	mVs /rad	248.1	253.6	250.0	280.9	264.2	280.4	311.9	268.0
E5-24	Motor Induction Voltage Constant 2 (Ke)	mV/(r/min)	0.0	0.0	0.0	0.0	0.0	0.0	0.0	0.0
E1-04	Maximum Output Frequency	Hz	87.5	87.5	87.5	87.5	87.5	87.5	87.5	87.5
E1-05	Maximum Voltage	V	190.0	190.0	190.0	190.0	190.0	190.0	190.0	190.0
E1-06	Base Frequency	Hz	87.5	87.5	87.5	87.5	87.5	87.5	87.5	87.5
E1-09	Minimum Output Frequency	Hz	4.4	4.4	4.4	4.4	4.4	4.4	4.4	4.4
C5-17	Motor Inertia	kgm ²	0.046	0.55	0.064	0.116	0.140	0.259	0.31	0.42
L3-24 <1>	Motor Acceleration Time for Inertia Calculations	s	0.102	0.101	0.098	0.130	0.127	0.193	0.191	0.187
n5-02	Motor Acceleration Time	s	0.102	0.101	0.098	0.130	0.127	0.193	0.191	0.187
n8-49	d-Axis Current for High Efficiency Control (OLV/PM)	%	-16.5	-11.3	-12.8	-16.8	-15.6	-10.7	-9.6	-13.3

<1> Default setting value varies depending on parameter o2-04, Drive Model Selection.

Table B.16 400 V, 1750 r/min Type Yaskawa SSR1 Series IPM Motor

No.	Name	Unit	Default Settings							
E5-01	Motor Code Selection	–	1232	1233	1235	1236	1238	123A	123B	123D
	Voltage Class	V	400	400	400	400	400	400	400	400
	Rated Power	kW	0.4	0.75	1.5	2.2	3.7	5.5	7.5	11
	Rated Speed	r/min	1750	1750	1750	1750	1750	1750	1750	1750
E5-02	Motor Rated Power	kW	0.4	0.75	1.5	2.2	3.7	5.5	7.5	11.0
E5-03	Motor Rated Current	A	0.89	1.56	2.81	4.27	7.08	10.31	13.65	20.7
E5-04	Number of Motor Poles	–	6	6	6	6	6	6	6	6
E5-05	Motor Stator Resistance (r1)	Ω	25.370	9.136	6.010	3.297	1.798	0.982	0.786	0.349
E5-06	Motor d-Axis Inductance (Ld)	mH	169.00	92.08	67.71	34.40	32.93	22.7	16.49	13.17
E5-07	Motor q-Axis Inductance (Lq)	mH	197.50	119.56	81.71	54.00	37.70	26.80	23.46	15.60
E5-09	Motor Induction Voltage Constant 1 (Ke)	mVs /rad	392.6	440.6	478.3	466.3	478.8	478.1	520.0	481.5
E5-24	Motor Induction Voltage Constant 2 (Ke)	mV/(r/min)	0.0	0.0	0.0	0.0	0.0	0.0	0.0	0.0
E1-04	Maximum Output Frequency	Hz	87.5	87.5	87.5	87.5	87.5	87.5	87.5	87.5
E1-05	Maximum Voltage	V	380.0	380.0	380.0	380.0	380.0	380.0	380.0	380.0
E1-06	Base Frequency	Hz	87.5	87.5	87.5	87.5	87.5	87.5	87.5	87.5
E1-09	Minimum Output Frequency	Hz	4.4	4.4	4.4	4.4	4.4	4.4	4.4	4.4
C5-17	Motor Inertia	kgm ²	0.0011	0.0017	0.0023	0.0043	0.0083	0.014	0.017	0.027
L3-24 <1>	Motor Acceleration Time for Inertia Calculations	s	0.092	0.076	0.052	0.066	0.075	0.083	0.077	0.084
n5-02	Motor Acceleration Time	s	0.092	0.076	0.052	0.066	0.075	0.083	0.077	0.084
n8-49	d-Axis Current for High Efficiency Control (OLV/PM)	%	-8.6	-11.5	-10.3	-19.8	-8.5	-11.0	-18.6	-12.5

<1> Default setting value varies depending on parameter o2-04, Drive Model Selection.

Table B.17 400 V, 1750 r/min Type Yaskawa SSR1 Series IPM Motor

No.	Name	Unit	Default Settings							
E5-01	Motor Code Selection	–	123E	123F	1240	1242	1243	1244	1245	1246
	Voltage Class	V	400	400	400	400	400	400	400	400
	Rated Power	kW	15	18	22	30	37	45	55	75
	Rated Speed	r/min	1750	1750	1750	1750	1750	1750	1750	1750
E5-02	Motor Rated Power	kW	15	18.50	22.00	30.00	37.00	45.00	55.00	75.00

B.19 Parameters Changed by Motor Code Selection

No.	Name	Unit	Default Settings							
E5-03	Motor Rated Current	A	27.5	33.4	39.8	52.0	65.8	77.5	92.7	126.6
E5-04	Number of Motor Poles	–	6	6	6	6	6	6	6	6
E5-05	Motor Stator Resistance (r1)	Ω	0.272	0.207	0.148	0.235	0.079	0.054	0.049	0.029
E5-06	Motor d-Axis Inductance (Ld)	mH	10.30	8.72	6.81	5.4	4.08	3.36	3.16	2.12
E5-07	Motor q-Axis Inductance (Lq)	mH	12.77	11.22	8.47	7.26	5.12	3.94	3.88	2.61
E5-09	Motor Induction Voltage Constant 1 (Ke)	mVs /rad	498.8	509.5	503.9	561.7	528.5	558.1	623.8	594.5
E5-24	Motor Induction Voltage Constant 2 (Ke)	mV/(r/min)	0.0	0.0	0.0	0.0	0.0	0.0	0.0	0.0
E1-04	Maximum Output Frequency	Hz	87.5	87.5	87.5	87.5	87.5	87.5	87.5	87.5
E1-05	Maximum Voltage	V	380.0	380.0	380.0	380.0	380.0	380.0	380.0	380.0
E1-06	Base Frequency	Hz	87.5	87.5	87.5	87.5	87.5	87.5	87.5	87.5
E1-09	Minimum Output Frequency	Hz	4.4	4.4	4.4	4.4	4.4	4.4	4.4	4.4
C5-17	Motor Inertia	kgm ²	0.046	0.055	0.064	0.116	0.140	0.259	0.31	0.42
L3-24 <1>	Motor Acceleration Time for Inertia Calculations	s	0.102	0.101	0.098	0.130	0.127	0.193	0.191	0.187
n5-02	Motor Acceleration Time	s	0.102	0.101	0.098	0.130	0.127	0.193	0.191	0.187
n8-49	d-Axis Current for High Efficiency Control (OLV/PM)	%	-15.5	-17.9	-15.1	-16.8	-14.1	-8.8	-9.6	-10.3

<1> Default setting value varies depending on parameter o2-04, Drive Model Selection.

Table B.18 400 V, 1750 r/min Type Yaskawa SSR1 Series IPM Motor

No.	Name	Unit	Default Settings							
E5-01	Motor Code Selection	–	1247	1248	1249	124A	1302	1303	1305	1306
	Voltage Class	V	400	400	400	400	200	200	200	200
	Rated Power	kW	90	110	132	160	0.4	0.75	1.5	2.2
	Rated Speed	r/min	1750	1750	1750	1750	1450	1450	1450	1450
E5-02	Motor Rated Power	kW	90.00	110.00	132.00	160.00	0.4	0.75	1.5	2.2
E5-03	Motor Rated Current	A	160.4	183.3	222.9	267.7	1.88	3.13	5.63	8.33
E5-04	Number of Motor Poles	–	6	6	6	6	6	6	6	6
E5-05	Motor Stator Resistance (r1)	Ω	0.019	0.017	0.012	0.008	3.190	1.940	1.206	0.665
E5-06	Motor d-Axis Inductance (Ld)	mH	1.54	1.44	1.21	0.97	32.15	26.12	14.72	12.27
E5-07	Motor q-Axis Inductance (Lq)	mH	2.06	2.21	1.46	1.28	41.74	34.30	20.15	14.77
E5-09	Motor Induction Voltage Constant 1 (Ke)	mVs /rad	524.1	583.7	563.6	601.2	264.3	269.6	284.3	287.1
E5-24	Motor Induction Voltage Constant 2 (Ke)	mV/(r/min)	0.0	0.0	0.0	0.0	0.0	0.0	0.0	0.0
E1-04	Maximum Output Frequency	Hz	87.5	87.5	87.5	87.5	72.5	72.5	72.5	72.5
E1-05	Maximum Voltage	V	380.0	380.0	380.0	380.0	190.0	190.0	190.0	190.0
E1-06	Base Frequency	Hz	87.5	87.5	87.5	87.5	72.5	72.5	72.5	72.5
E1-09	Minimum Output Frequency	Hz	4.4	4.4	4.4	4.4	3.6	3.6	3.6	3.6
C5-17	Motor Inertia	kgm ²	0.56	0.83	0.96	1.61	0.0017	0.0023	0.0043	0.0083
L3-24 <1>	Motor Acceleration Time for Inertia Calculations	s	0.208	0.254	0.243	0.338	0.098	0.071	0.066	0.087
n5-02	Motor Acceleration Time	s	0.208	0.254	0.243	0.338	0.098	0.071	0.066	0.087
n8-49	d-Axis Current for High Efficiency Control (OLV/PM)	%	-17.0	-21.7	-10.9	-13.2	-6.6	-10.9	-13.5	-9.0

<1> Default setting value varies depending on parameter o2-04, Drive Model Selection.

B.19 Parameters Changed by Motor Code Selection

Table B.19 200 V, 1450 r/min Type Yaskawa SSR1 Series IPM Motor

No.	Name	Unit	Default Settings							
E5-01	Motor Code Selection	–	1308	130A	130B	130D	130E	130F	1310	1312
	Voltage Class	V	200	200	200	200	200	200	200	200
	Rated Power	kW	3.7	5.5	7.5	11	15	18	22	30
	Rated Speed	r/min	1450	1450	1450	1450	1450	1450	1450	1450
E5-02	Motor Rated Power	kW	3.7	5.5	7.5	11.0	15.00	18.00	22.00	30.00
E5-03	Motor Rated Current	A	14.17	20.63	27.71	39.6	55.5	65.6	75.1	105.2
E5-04	Number of Motor Poles	–	6	6	6	6	6	6	6	6
E5-05	Motor Stator Resistance (r1)	Ω	0.341	0.252	0.184	0.099	0.075	0.057	0.041	0.034
E5-06	Motor d-Axis Inductance (Ld)	mH	8.27	6.49	6.91	4.07	3.29	2.53	1.98	1.75
E5-07	Motor q-Axis Inductance (Lq)	mH	9.81	7.74	7.66	4.65	3.84	3.01	2.60	2.17
E5-09	Motor Induction Voltage Constant 1 (Ke)	mVs /rad	284.5	298.0	335.0	303.9	311.2	300.9	327.7	354.2
E5-24	Motor Induction Voltage Constant 2 (Ke)	mV/ (r/min)	0.0	0.0	0.0	0.0	0.0	0.0	0.0	0.0
E1-04	Maximum Output Frequency	Hz	72.5	72.5	72.5	72.5	72.5	72.5	72.5	72.5
E1-05	Maximum Voltage	V	190.0	190.0	190.0	190.0	190.0	190.0	190.0	190.0
E1-06	Base Frequency	Hz	72.5	72.5	72.5	72.5	72.5	72.5	72.5	72.5
E1-09	Minimum Output Frequency	Hz	3.6	3.6	3.6	3.6	3.6	3.6	3.6	3.6
C5-17	Motor Inertia	kgm ²	0.0136	0.017	0.027	0.046	0.055	0.064	0.116	0.140
L3-24 <1>	Motor Acceleration Time for Inertia Calculations	s	0.085	0.072	0.084	0.096	0.085	0.080	0.122	0.108
n5-02	Motor Acceleration Time	s	0.085	0.072	0.084	0.096	0.085	0.080	0.122	0.108
n8-49	d-Axis Current for High Efficiency Control (OLV/PM)	%	-9.5	-10.1	-6.0	-9.3	-10.7	-13.2	-15.7	-11.5

<1> Default setting value varies depending on parameter o2-04, Drive Model Selection.

Table B.20 200 V, 1450 r/min Type Yaskawa SSR1 Series IPM Motor

No.	Name	Unit	Default Settings							
E5-01	Motor Code Selection	–	1313	1314	1315	1332	1333	1335	1336	1338
	Voltage Class	V	200	200	200	400	400	400	400	400
	Rated Power	kW	37	45	55	0.4	0.75	1.5	2.2	3.7
	Rated Speed	r/min	1450	1450	1450	1450	1450	1450	1450	1450
E5-02	Motor Rated Power	kW	37.00	45.00	55.00	0.4	0.75	1.5	2.2	3.7
E5-03	Motor Rated Current	A	126.0	153.1	186.5	0.94	1.56	2.81	4.27	6.98
E5-04	Number of Motor Poles	–	6	6	6	6	6	6	6	6
E5-05	Motor Stator Resistance (r1)	Ω	0.023	0.015	0.012	12.760	7.421	4.825	2.656	1.353
E5-06	Motor d-Axis Inductance (Ld)	mH	1.48	1.04	0.87	128.60	85.11	58.87	46.42	31.73
E5-07	Motor q-Axis Inductance (Lq)	mH	1.70	1.31	1.10	166.96	113.19	80.59	60.32	40.45
E5-09	Motor Induction Voltage Constant 1 (Ke)	mVs /rad	369.6	351.6	374.7	528.6	544.2	568.5	572.8	562.9
E5-24	Motor Induction Voltage Constant 2 (Ke)	mV/ (r/min)	0.0	0.0	0.0	0.0	0.0	0.0	0.0	0.0
E1-04	Maximum Output Frequency	Hz	72.5	72.5	72.5	72.5	72.5	72.5	72.5	72.5
E1-05	Maximum Voltage	V	190.0	190.0	190.0	380.0	380.0	380.0	380.0	380.0
E1-06	Base Frequency	Hz	72.5	72.5	72.5	72.5	72.5	72.5	72.5	72.5
E1-09	Minimum Output Frequency	Hz	3.6	3.6	3.6	3.6	3.6	3.6	3.6	3.6
C5-17	Motor Inertia	kgm ²	0.259	0.312	0.42	0.0017	0.0023	0.0043	0.0083	0.0136
L3-24 <1>	Motor Acceleration Time for Inertia Calculations	s	0.161	0.160	0.175	0.098	0.071	0.066	0.087	0.085
n5-02	Motor Acceleration Time	s	0.161	0.160	0.175	0.098	0.071	0.066	0.087	0.085
n8-49	d-Axis Current for High Efficiency Control (OLV/PM)	%	-7.0	-11.8	-10.2	-6.6	-9.2	-13.5	-12.1	-13.7

<1> Default setting value varies depending on parameter o2-04, Drive Model Selection.

Table B.21 400 V, 1450 r/min Type Yaskawa SSR1 Series IPM Motor

No.	Name	Unit	Default Settings							
			133A	133B	133D	133E	133F	1340	1342	1343
E5-01	Motor Code Selection	–	133A	133B	133D	133E	133F	1340	1342	1343
	Voltage Class	V	400	400	400	400	400	400	400	400
	Rated Power	kW	5.5	7.5	11	15	18	22	30	37
	Rated Speed	r/min	1450	1450	1450	1450	1450	1450	1450	1450
E5-02	Motor Rated Power	kW	5.5	7.5	11.0	15	18.50	22.00	30.00	37.00
E5-03	Motor Rated Current	A	10.21	13.85	19.5	27.4	32.9	37.6	52.5	63.2
E5-04	Number of Motor Poles	–	6	6	6	6	6	6	6	6
E5-05	Motor Stator Resistance (r1)	Ω	0.999	0.713	0.393	0.295	0.223	0.164	0.137	0.093
E5-06	Motor d-Axis Inductance (Ld)	mH	26.20	27.06	15.51	12.65	9.87	7.90	7.01	5.93
E5-07	Motor q-Axis Inductance (Lq)	mH	30.94	33.45	19.63	15.87	12.40	10.38	8.68	6.79
E5-09	Motor Induction Voltage Constant 1 (Ke)	mVs /rad	587.6	670.1	612.7	624.6	610.4	655.4	708.4	739.2
E5-24	Motor Induction Voltage Constant 2 (Ke)	mV/ (r/min)	0.0	0.0	0.0	0.0	0.0	0.0	0.0	0.0
E1-04	Maximum Output Frequency	Hz	72.5	72.5	72.5	72.5	72.5	72.5	72.5	72.5
E1-05	Maximum Voltage	V	380.0	380.0	380.0	380.0	380.0	380.0	380.0	380.0
E1-06	Base Frequency	Hz	72.5	72.5	72.5	72.5	72.5	72.5	72.5	72.5
E1-09	Minimum Output Frequency	Hz	3.6	3.6	3.6	3.6	3.6	3.6	3.6	3.6
C5-17	Motor Inertia	kgm ²	0.017	0.027	0.046	0.055	0.064	0.116	0.140	0.259
L3-24 <1>	Motor Acceleration Time for Inertia Calculations	s	0.072	0.084	0.096	0.085	0.080	0.122	0.108	0.161
n5-02	Motor Acceleration Time	s	0.072	0.084	0.096	0.085	0.080	0.122	0.108	0.161
n8-49	d-Axis Current for High Efficiency Control (OLV/ PM)	%	-10.1	-12.2	-15.5	-15.1	-16.0	-15.7	-11.5	-6.8

<1> Default setting value varies depending on parameter o2-04, Drive Model Selection.

Table B.22 400 V, 1450 r/min Type Yaskawa SSR1 Series IPM Motor

No.	Name	Unit	Default Settings							
			1344	1345	1346	1347	1348	1349	1402	1403
E5-01	Motor Code Selection	–	1344	1345	1346	1347	1348	1349	1402	1403
	Voltage Class	V	400	400	400	400	400	400	200	200
	Rated Power	kW	45	55	75	90	110	132	0.4	0.75
	Rated Speed	r/min	1450	1450	1450	1450	1450	1450	1150	1150
E5-02	Motor Rated Power	kW	45.00	55.00	75.00	90.00	110.00	132.00	0.4	0.75
E5-03	Motor Rated Current	A	76.4	96.1	124.0	153.1	186.5	226.0	1.88	3.02
E5-04	Number of Motor Poles	–	6	6	6	6	6	6	6	6
E5-05	Motor Stator Resistance (r1)	Ω	0.059	0.048	0.028	0.024	0.015	0.011	4.832	2.704
E5-06	Motor d-Axis Inductance (Ld)	mH	4.17	3.11	2.32	2.20	1.45	1.23	48.68	32.31
E5-07	Motor q-Axis Inductance (Lq)	mH	5.22	4.55	2.97	3.23	1.88	1.67	63.21	40.24
E5-09	Motor Induction Voltage Constant 1 (Ke)	mVs /rad	703.0	747.1	639.3	708.0	640.7	677.0	320.4	327.1
E5-24	Motor Induction Voltage Constant 2 (Ke)	mV/ (r/min)	0.0	0.0	0.0	0.0	0.0	0.0	0.0	0.0
E1-04	Maximum Output Frequency	Hz	72.5	72.5	72.5	72.5	72.5	72.5	57.5	57.5
E1-05	Maximum Voltage	V	380.0	380.0	380.0	380.0	380.0	380.0	190.0	190.0
E1-06	Base Frequency	Hz	72.5	72.5	72.5	72.5	72.5	72.5	57.5	57.5
E1-09	Minimum Output Frequency	Hz	3.6	3.6	3.6	3.6	3.6	3.6	2.9	2.9
C5-17	Motor Inertia	kgm ²	0.312	0.42	0.56	0.83	0.96	1.61	0.0017	0.0023
L3-24 <1>	Motor Acceleration Time for Inertia Calculations	s	0.160	0.175	0.171	0.213	0.201	0.281	0.062	0.044
n5-02	Motor Acceleration Time	s	0.160	0.175	0.171	0.213	0.201	0.281	0.062	0.044

B.19 Parameters Changed by Motor Code Selection

No.	Name	Unit	Default Settings							
n8-49	d-Axis Current for High Efficiency Control (OLV/PM)	%	-11.5	-14.8	-15.8	-19.6	-14.9	-15.1	-8.8	-9.9

<1> Default setting value varies depending on parameter o2-04, Drive Model Selection.

Table B.23 200 V, 1150 r/min Type Yaskawa SSR1 Series IPM Motor

No.	Name	Unit	Default Settings							
E5-01	Motor Code Selection	–	1405	1406	1408	140A	140B	140D	140E	140F
	Voltage Class	V	200	200	200	200	200	200	200	200
	Rated Power	kW	1.5	2.2	3.7	5.5	7.5	11.0	15	18.00
	Rated Speed	r/min	1150	1150	1150	1150	1150	1150	1150	1150
E5-02	Motor Rated Power	kW	1.5	2.2	3.7	5.5	7.5	11	15	18.5
E5-03	Motor Rated Current	A	6.00	8.85	14.27	20.21	26.67	39.9	55.6	63.5
E5-04	Number of Motor Poles	–	6	6	6	6	6	6	6	6
E5-05	Motor Stator Resistance (r1)	Ω	1.114	0.511	0.412	0.303	0.165	0.113	0.084	0.066
E5-06	Motor d-Axis Inductance (Ld)	mH	19.22	12.15	7.94	11.13	6.59	4.96	3.83	3.33
E5-07	Motor q-Axis Inductance (Lq)	mH	24.38	15.35	11.86	14.06	8.55	6.12	4.65	4.5
E5-09	Motor Induction Voltage Constant 1 (Ke)	mVs /rad	364.4	344.4	357.5	430.8	391.5	384.4	372.1	421.3
E5-24	Motor Induction Voltage Constant 2 (Ke)	mV/(r/min)	0.0	0.0	0.0	0.0	0.0	0.0	0.0	0.0
E1-04	Maximum Output Frequency	Hz	57.5	57.5	57.5	57.5	57.5	57.5	57.5	57.5
E1-05	Maximum Voltage	V	190.0	190.0	190.0	190.0	190.0	190.0	190.0	190.0
E1-06	Base Frequency	Hz	57.5	57.5	57.5	57.5	57.5	57.5	57.5	57.5
E1-09	Minimum Output Frequency	Hz	2.9	2.9	2.9	2.9	2.9	2.9	2.9	2.9
C5-17	Motor Inertia	kgm ²	0.0083	0.0136	0.0171	0.027	0.046	0.055	0.064	0.116
L3-24 <1>	Motor Acceleration Time for Inertia Calculations	s	0.080	0.090	0.067	0.072	0.088	0.073	0.062	0.091
n5-02	Motor Acceleration Time	s	0.080	0.090	0.067	0.072	0.088	0.073	0.062	0.091
n8-49	d-Axis Current for High Efficiency Control (OLV/PM)	%	-9.3	-10.0	-17.7	-12.3	-15.3	-13.9	-14.4	-17.9

<1> Default setting value varies depending on parameter o2-04, Drive Model Selection.

Table B.24 200 V, 1150 r/min Type Yaskawa SSR1 Series IPM Motor

No.	Name	Unit	Default Settings							
E5-01	Motor Code Selection	–	1410	1412	1413	1414	1432	1433	1435	1436
	Voltage Class	V	200	200	200	200	400	400	400	400
	Rated Power	kW	22.00	30.00	37.00	45.00	0.4	0.75	1.5	2.2
	Rated Speed	r/min	1150	1150	1150	1150	1150	1150	1150	1150
E5-02	Motor Rated Power	kW	22	30	37	45	0.4	0.75	1.5	2.2
E5-03	Motor Rated Current	A	74.4	104.2	129.6	154.2	0.94	1.51	3.00	4.43
E5-04	Number of Motor Poles	–	6	6	6	6	6	6	6	6
E5-05	Motor Stator Resistance (r1)	Ω	0.048	0.035	0.023	0.016	19.320	10.800	4.456	2.044
E5-06	Motor d-Axis Inductance (Ld)	mH	2.38	2.04	1.53	1.16	194.70	129.20	76.88	48.60
E5-07	Motor q-Axis Inductance (Lq)	mH	3.15	2.86	2.27	1.54	252.84	160.90	97.52	61.40
E5-09	Motor Induction Voltage Constant 1 (Ke)	mVs /rad	410.9	436.1	428.8	433.3	640.9	654.1	728.8	688.9
E5-24	Motor Induction Voltage Constant 2 (Ke)	mV/(r/min)	0.0	0.0	0.0	0.0	0.0	0.0	0.0	0.0
E1-04	Maximum Output Frequency	Hz	57.5	57.5	57.5	57.5	57.5	57.5	57.5	57.5
E1-05	Maximum Voltage	V	190.0	190.0	190.0	190.0	380.0	380.0	380.0	380.0
E1-06	Base Frequency	Hz	57.5	57.5	57.5	57.5	57.5	57.5	57.5	57.5
E1-09	Minimum Output Frequency	Hz	2.9	2.9	2.9	2.9	2.9	2.9	2.9	2.9
C5-17	Motor Inertia	kgm ²	0.14	0.259	0.312	0.418	0.0017	0.0023	0.0083	0.0136
L3-24 <1>	Motor Acceleration Time for Inertia Calculations	s	0.092	0.125	0.122	0.135	0.062	0.044	0.080	0.090

B.19 Parameters Changed by Motor Code Selection

No.	Name	Unit	Default Settings							
n5-02	Motor Acceleration Time	s	0.092	0.125	0.122	0.135	0.062	0.044	0.080	0.090
n8-49	d-Axis Current for High Efficiency Control (OLV/PM)	%	-15.9	-17.9	-20.1	-13.7	-8.8	-9.9	-9.3	-10.0

<1> Default setting value varies depending on parameter o2-04, Drive Model Selection.

Table B.25 400 V, 1150 r/min Type Yaskawa SSR1 Series IPM Motor

No.	Name	Unit	Default Settings							
E5-01	Motor Code Selection	–	1438	143A	143B	143D	143E	143F	1440	1442
	Voltage Class	V	400	400	400	400	400	400	400	400
	Rated Power	kW	3.7	5.5	7.5	11	15	18	22	30
	Rated Speed	r/min	1150	1150	1150	1150	1150	1150	1150	1150
E5-02	Motor Rated Power	kW	3.7	5.5	7.5	11.0	15	18.50	22.00	30.00
E5-03	Motor Rated Current	A	7.08	10.10	13.33	19.9	27.8	31.8	37.2	52.1
E5-04	Number of Motor Poles	–	6	6	6	6	6	6	6	6
E5-05	Motor Stator Resistance (r1)	Ω	1.483	1.215	0.660	0.443	0.331	0.264	0.192	0.140
E5-06	Motor d-Axis Inductance (Ld)	mH	37.58	44.54	26.36	19.10	15.09	13.32	9.52	8.16
E5-07	Motor q-Axis Inductance (Lq)	mH	47.65	56.26	34.20	24.67	18.56	18.00	12.60	11.40
E5-09	Motor Induction Voltage Constant 1 (Ke)	mVs /rad	702.0	861.5	783.0	762.2	749.6	842.7	821.8	872.3
E5-24	Motor Induction Voltage Constant 2 (Ke)	mV/ (r/min)	0.0	0.0	0.0	0.0	0.0	0.0	0.0	0.0
E1-04	Maximum Output Frequency	Hz	57.5	57.5	57.5	57.5	57.5	57.5	57.5	57.5
E1-05	Maximum Voltage	V	380.0	380.0	380.0	380.0	380.0	380.0	380.0	380.0
E1-06	Base Frequency	Hz	57.5	57.5	57.5	57.5	57.5	57.5	57.5	57.5
E1-09	Minimum Output Frequency	Hz	2.9	2.9	2.9	2.9	2.9	2.9	2.9	2.9
C5-17	Motor Inertia	kgm ²	0.0171	0.027	0.046	0.055	0.064	0.116	0.140	0.259
L3-24 <1>	Motor Acceleration Time for Inertia Calculations	s	0.067	0.072	0.088	0.073	0.062	0.091	0.092	0.125
n5-02	Motor Acceleration Time	s	0.067	0.072	0.088	0.073	0.062	0.091	0.092	0.125
n8-49	d-Axis Current for High Efficiency Control (OLV/PM)	%	-12.8	-12.3	-15.3	-16.7	-14.9	-17.9	-15.9	-17.7

<1> Default setting value varies depending on parameter o2-04, Drive Model Selection.

Table B.26 400 V, 1150 r/min Type Yaskawa SSR1 Series IPM Motor

No.	Name	Unit	Default Settings							
E5-01	Motor Code Selection	–	1443	1444	1445	1446	1447	1448		
	Voltage Class	V	400	400	400	400	400	400	400	
	Rated Power	kW	37	45	55	75	90	110		
	Rated Speed	r/min	1150	1150	1150	1150	1150	1150	1150	
E5-02	Motor Rated Power	kW	37.00	45.00	55.00	75.00	90.00	110.00		
E5-03	Motor Rated Current	A	64.8	76.6	92.0	127.1	150.5	185.4		
E5-04	Number of Motor Poles	–	6	6	6	6	6	6	6	
E5-05	Motor Stator Resistance (r1)	Ω	0.093	0.063	0.051	0.033	0.027	0.015		
E5-06	Motor d-Axis Inductance (Ld)	mH	6.13	4.63	3.96	3.03	2.60	1.89		
E5-07	Motor q-Axis Inductance (Lq)	mH	9.10	6.15	5.00	5.14	3.28	2.33		
E5-09	Motor Induction Voltage Constant 1 (Ke)	mVs /rad	857.7	866.6	854.0	823.1	853.4	829.2		
E5-24	Motor Induction Voltage Constant 2 (Ke)	mV/ (r/min)	0.0	0.0	0.0	0.0	0.0	0.0		
E1-04	Maximum Output Frequency	Hz	57.5	57.5	57.5	57.5	57.5	57.5		
E1-05	Maximum Voltage	V	380.0	380.0	380.0	380.0	380.0	380.0		
E1-06	Base Frequency	Hz	57.5	57.5	57.5	57.5	57.5	57.5		
E1-09	Minimum Output Frequency	Hz	2.9	2.9	2.9	2.9	2.9	2.9		
C5-17	Motor Inertia	kgm ²	0.312	0.418	0.56	0.83	0.96	1.61		

B.19 Parameters Changed by Motor Code Selection

No.	Name	Unit	Default Settings					
L3-24 </>	Motor Acceleration Time for Inertia Calculations	s	0.122	0.135	0.147	0.161	0.154	0.212
n5-02	Motor Acceleration Time	s	0.122	0.135	0.147	0.161	0.154	0.212
n8-49	d-Axis Current for High Efficiency Control (OLV/PM)	%	-20.1	-13.8	-12.5	-28.8	-13.3	-11.6

<1> Default setting value varies depending on parameter o2-04, Drive Model Selection.

◆ Yaskawa SST4 Series IPM Motor (For Constant Torque)

Table B.27 200 V, 1750 r/min Type Yaskawa SST4 Series IPM Motor

No.	Name	Unit	Default Settings							
E5-01	Motor Code Selection	-	2202	2203	2205	2206	2208	220A	220B	220D
	Voltage Class	V	200	200	200	200	200	200	200	200
	Rated Power	kW	0.4	0.75	1.5	2.2	3.7	5.5	7.5	11
	Rated Speed	r/min	1750	1750	1750	1750	1750	1750	1750	1750
E5-02	Motor Rated Power	kW	0.4	0.75	1.5	2.2	3.7	5.5	7.5	11.0
E5-03	Motor Rated Current	A	1.77	3.54	6.56	8.96	14.79	20.94	29.58	41.1
E5-04	Number of Motor Poles	-	6	6	6	6	6	6	6	6
E5-05	Motor Stator Resistance (r1)	Ω	2.247	1.132	0.774	0.479	0.242	0.275	0.161	0.111
E5-06	Motor d-Axis Inductance (Ld)	mH	22.32	12.38	8.90	7.39	5.06	5.82	3.86	3.59
E5-07	Motor q-Axis Inductance (Lq)	mH	32.50	15.72	11.96	9.63	6.42	6.74	4.66	4.32
E5-09	Motor Induction Voltage Constant 1 (Ke)	mVs/rad	215.2	203.9	219.3	230.6	235.1	251.7	235.7	252.0
E5-24	Motor Induction Voltage Constant 2 (Ke)	mV/(r/min)	0.0	0.0	0.0	0.0	0.0	0.0	0.0	0.0
E1-04	Maximum Output Frequency	Hz	87.5	87.5	87.5	87.5	87.5	87.5	87.5	87.5
E1-05	Maximum Voltage	V	190.0	190.0	190.0	190.0	190.0	190.0	190.0	190.0
E1-06	Base Frequency	Hz	87.5	87.5	87.5	87.5	87.5	87.5	87.5	87.5
E1-09	Minimum Output Frequency	Hz	4.4	4.4	4.4	4.4	4.4	4.4	4.4	4.4
C5-17	Motor Inertia	kgm ²	0.0016	0.0022	0.0042	0.0081	0.0133	0.013	0.017	0.027
L3-24 </>	Motor Acceleration Time for Inertia Calculations	s	0.134	0.099	0.094	0.124	0.121	0.081	0.075	0.082
n5-02	Motor Acceleration Time	s	0.134	0.099	0.094	0.124	0.121	0.081	0.075	0.082
n8-49	d-Axis Current for High Efficiency Control (OLV/PM)	%	-9.3	-6.4	-10.0	-9.9	-9.7	-8.4	-11.5	-13.1

<1> Default setting value varies depending on parameter o2-04, Drive Model Selection.

Table B.28 200 V, 1750 r/min Type Yaskawa SST4 Series IPM Motor

No.	Name	Unit	Default Settings							
E5-01	Motor Code Selection	-	220E	220F	2210	2212	2213	2214	2215	2216
	Voltage Class	V	200	200	200	200	200	200	200	200
	Rated Power	kW	15	18	22	30	37	45	55	75
	Rated Speed	r/min	1750	1750	1750	1750	1750	1750	1750	1750
E5-02	Motor Rated Power	kW	15	18.50	22.00	30.00	37.00	45.00	55.00	75.00
E5-03	Motor Rated Current	A	54.2	68.2	78.6	104.2	129.2	153.1	205.2	260.4
E5-04	Number of Motor Poles	-	6	6	6	6	6	6	6	6
E5-05	Motor Stator Resistance (r1)	Ω	0.071	0.049	0.040	0.030	0.020	0.013	0.009	0.006
E5-06	Motor d-Axis Inductance (Ld)	mH	2.67	1.98	1.69	1.31	0.88	0.77	0.55	0.40
E5-07	Motor q-Axis Inductance (Lq)	mH	3.1	2.41	2.12	1.61	1.14	1.04	0.69	0.50
E5-09	Motor Induction Voltage Constant 1 (Ke)	mVs/rad	253.7	244.6	256.3	283.1	266.3	260	261.5	259.3
E5-24	Motor Induction Voltage Constant 2 (Ke)	mV/(r/min)	0.0	0.0	0.0	0.0	0.0	0.0	0.0	0.0
E1-04	Maximum Output Frequency	Hz	87.5	87.5	87.5	87.5	87.5	87.5	87.5	87.5
E1-05	Maximum Voltage	V	190.0	190.0	190.0	190.0	190.0	190.0	190.0	190.0

B.19 Parameters Changed by Motor Code Selection

No.	Name	Unit	Default Settings							
E1-06	Base Frequency	Hz	87.5	87.5	87.5	87.5	87.5	87.5	87.5	87.5
E1-09	Minimum Output Frequency	Hz	4.4	4.4	4.4	4.4	4.4	4.4	4.4	4.4
C5-17	Motor Inertia	kgm ²	0.044	0.054	0.063	0.113	0.137	0.252	0.30	0.41
L3-24 </>	Motor Acceleration Time for Inertia Calculations	s	0.099	0.098	0.096	0.127	0.124	0.188	0.186	0.184
n5-02	Motor Acceleration Time	s	0.099	0.098	0.096	0.127	0.124	0.188	0.186	0.184
n8-49	d-Axis Current for High Efficiency Control (OLV/PM)	%	-10.9	-14.3	-15.1	-11.3	-14.1	-18.8	-11.4	-12.2

<1> Default setting value varies depending on parameter o2-04, Drive Model Selection.

Table B.29 400 V, 1750 r/min Type Yaskawa SST4 Series IPM Motor

No.	Name	Unit	Default Settings							
E5-01	Motor Code Selection	-	2232	2233	2235	2236	2238	223A	223B	223D
	Voltage Class	V	400	400	400	400	400	400	400	400
	Rated Power	kW	0.4	0.75	1.5	2.2	3.7	5.5	7.5	11
	Rated Speed	r/min	1750	1750	1750	1750	1750	1750	1750	1750
E5-02	Motor Rated Power	kW	0.4	0.75	1.5	2.2	3.7	5.5	7.5	11.0
E5-03	Motor Rated Current	A	0.92	1.77	3.33	4.48	7.50	10.42	14.27	20.5
E5-04	Number of Motor Poles	-	6	6	6	6	6	6	6	6
E5-05	Motor Stator Resistance (r1)	Ω	8.935	4.570	3.096	1.906	0.972	1.103	0.630	0.429
E5-06	Motor d-Axis Inductance (Ld)	mH	80.14	48.04	35.60	30.31	20.03	23.41	14.86	14.34
E5-07	Motor q-Axis Inductance (Lq)	mH	110.76	64.88	47.84	38.36	24.97	28.70	17.25	17.25
E5-09	Motor Induction Voltage Constant 1 (Ke)	mVs /rad	416.5	399.4	438.5	475.5	463.7	485.8	470.4	513.4
E5-24	Motor Induction Voltage Constant 2 (Ke)	mV/ (r/min)	0.0	0.0	0.0	0.0	0.0	0.0	0.0	0.0
E1-04	Maximum Output Frequency	Hz	87.5	87.5	87.5	87.5	87.5	87.5	87.5	87.5
E1-05	Maximum Voltage	V	380.0	380.0	380.0	380.0	380.0	380.0	380.0	380.0
E1-06	Base Frequency	Hz	87.5	87.5	87.5	87.5	87.5	87.5	87.5	87.5
E1-09	Minimum Output Frequency	Hz	4.4	4.4	4.4	4.4	4.4	4.4	4.4	4.4
C5-17	Motor Inertia	kgm ²	0.0016	0.0022	0.0042	0.0081	0.0133	0.013	0.017	0.027
L3-24 </>	Motor Acceleration Time for Inertia Calculations	s	0.134	0.099	0.094	0.124	0.121	0.081	0.075	0.082
n5-02	Motor Acceleration Time	s	0.134	0.099	0.094	0.124	0.121	0.081	0.075	0.082
n8-49	d-Axis Current for High Efficiency Control (OLV/PM)	%	-7.5	-8.5	-9.8	-8.2	-9.1	-13.1	-9.2	-12.4

<1> Default setting value varies depending on parameter o2-04, Drive Model Selection.

Table B.30 400 V, 1750 r/min Type Yaskawa SST4 Series IPM Motor

No.	Name	Unit	Default Settings							
E5-01	Motor Code Selection	-	223E	223F	2240	2242	2243	2244	2245	2246
	Voltage Class	V	400	400	400	400	400	400	400	400
	Rated Power	kW	15	18	22	30	37	45	55	75
	Rated Speed	r/min	1750	1750	1750	1750	1750	1750	1750	1750
E5-02	Motor Rated Power	kW	15	18.50	22.00	30.00	37.00	45.00	55.00	75.00
E5-03	Motor Rated Current	A	26.4	34.2	38.8	52.2	65.4	77.6	99.3	130.2
E5-04	Number of Motor Poles	-	6	6	6	6	6	6	6	6
E5-05	Motor Stator Resistance (r1)	Ω	0.275	0.196	0.160	0.120	0.077	0.052	0.036	0.023
E5-06	Motor d-Axis Inductance (Ld)	mH	9.99	7.92	6.82	5.24	3.57	2.98	1.59	1.59
E5-07	Motor q-Axis Inductance (Lq)	mH	12.37	9.64	8.51	6.44	4.65	3.75	2.78	1.97
E5-09	Motor Induction Voltage Constant 1 (Ke)	mVs /rad	505.3	489.2	509.5	566.2	531.6	530.6	515.2	515.2

B.19 Parameters Changed by Motor Code Selection

No.	Name	Unit	Default Settings							
E5-24	Motor Induction Voltage Constant 2 (Ke)	mV/(r/min)	0.0	0.0	0.0	0.0	0.0	0.0	0.0	0.0
E1-04	Maximum Output Frequency	Hz	87.5	87.5	87.5	87.5	87.5	87.5	87.5	87.5
E1-05	Maximum Voltage	V	380.0	380.0	380.0	380.0	380.0	380.0	380.0	380.0
E1-06	Base Frequency	Hz	87.5	87.5	87.5	87.5	87.5	87.5	87.5	87.5
E1-09	Minimum Output Frequency	Hz	4.4	4.4	4.4	4.4	4.4	4.4	4.4	4.4
C5-17	Motor Inertia	kgm ²	0.044	0.054	0.063	0.113	0.137	0.252	0.30	0.41
L3-24 <1>	Motor Acceleration Time for Inertia Calculations	s	0.099	0.098	0.096	0.127	0.124	0.188	0.186	0.184
n5-02	Motor Acceleration Time	s	0.099	0.098	0.096	0.127	0.124	0.188	0.186	0.184
n8-49	d-Axis Current for High Efficiency Control (OLV/PM)	%	-15.1	-14.3	-15.3	-11.3	-14.5	-13.2	-22.6	-11.9

<1> Default setting value varies depending on parameter o2-04, Drive Model Selection.

Table B.31 400 V, 1750 r/min Type Yaskawa SST4 Series IPM Motor

No.	Name	Unit	Default Settings							
E5-01	Motor Code Selection	-	2247	2248	2249	224A	224C	224D	224E	2302
	Voltage Class	V	400	400	400	400	400	400	400	200
	Rated Power	kW	90.00	110	132	160	200	220	300	0.4
	Rated Speed	r/min	1750	1750	1750	1750	1750	1750	1750	1450
E5-02	Motor Rated Power	kW	90.00	110.00	132.00	160.00	200.00	250.00	300.00	0.4
E5-03	Motor Rated Current	A	153.1	184.4	229.2	269.8	346.9	421.9	520.8	1.77
E5-04	Number of Motor Poles	-	6	6	6	6	6	6	6	6
E5-05	Motor Stator Resistance (r1)	Ω	0.019	0.017	0.012	0.008	0.005	0.004	0.002	3.154
E5-06	Motor d-Axis Inductance (Ld)	mH	1.51	1.43	1.13	0.96	0.65	0.67	0.40	28.46
E5-07	Motor q-Axis Inductance (Lq)	mH	1.76	1.92	1.54	1.26	0.88	0.74	0.52	39.29
E5-09	Motor Induction Voltage Constant 1 (Ke)	mVs/rad	538.3	590.9	548.2	603.9	556.8	593.1	495.4	268.8
E5-24	Motor Induction Voltage Constant 2 (Ke)	mV/(r/min)	0.0	0.0	0.0	0.0	0.0	0.0	0.0	0.0
E1-04	Maximum Output Frequency	Hz	87.5	87.5	87.5	87.5	87.5	87.5	87.5	72.5
E1-05	Maximum Voltage	V	380.0	380.0	380.0	380.0	380.0	380.0	380.0	190.0
E1-06	Base Frequency	Hz	87.5	87.5	87.5	87.5	87.5	87.5	87.5	72.5
E1-09	Minimum Output Frequency	Hz	4.4	4.4	4.4	4.4	4.4	4.4	4.4	3.6
C5-17	Motor Inertia	kgm ²	0.55	0.82	0.96	1.60	1.95	2.82	3.70	0.0016
L3-24 <1>	Motor Acceleration Time for Inertia Calculations	s	0.205	0.250	0.244	0.336	0.327	0.379	0.414	0.092
n5-02	Motor Acceleration Time	s	0.205	0.250	0.244	0.336	0.327	0.379	0.414	0.092
n8-49	d-Axis Current for High Efficiency Control (OLV/PM)	%	-8.6	-14.8	-17.5	-12.5	-14.7	-5.1	-16.3	-7.5

<1> Default setting value varies depending on parameter o2-04, Drive Model Selection.

Table B.32 200 V, 1450 r/min Type Yaskawa SST4 Series IPM Motor

No.	Name	Unit	Default Settings							
E5-01	Motor Code Selection	-	2302	2303	2305	2306	2308	230A	230B	230D
	Voltage Class	V	200	200	200	200	200	200	200	200
	Rated Power	kW	0.4	0.75	1.5	2.2	3.7	5.5	7.5	11
	Rated Speed	r/min	1450	1450	1450	1450	1450	1450	1450	1450
E5-02	Motor Rated Power	kW	0.4	0.75	1.5	2.2	3.7	5.5	7.5	11.0
E5-03	Motor Rated Current	A	1.77	3.33	5.94	9.48	14.17	20.42	27.92	39.6
E5-04	Number of Motor Poles	-	6	6	6	6	6	6	6	6
E5-05	Motor Stator Resistance (r1)	Ω	3.154	1.835	0.681	0.308	0.405	0.278	0.180	0.098

B.19 Parameters Changed by Motor Code Selection

No.	Name	Unit	Default Settings							
E5-06	Motor d-Axis Inductance (Ld)	mH	28.46	19.46	10.00	6.88	8.15	5.77	6.32	3.34
E5-07	Motor q-Axis Inductance (Lq)	mH	39.29	25.89	15.20	9.25	10.76	8.60	8.80	4.61
E5-09	Motor Induction Voltage Constant 1 (Ke)	mVs /rad	268.8	256.9	271.9	260.2	286.8	314.9	300.8	292.3
E5-24	Motor Induction Voltage Constant 2 (Ke)	mV/(r/min)	0.0	0.0	0.0	0.0	0.0	0.0	0.0	0.0
E1-04	Maximum Output Frequency	Hz	72.5	72.5	72.5	72.5	72.5	72.5	72.5	72.5
E1-05	Maximum Voltage	V	190.0	190.0	190.0	190.0	190.0	190.0	190.0	190.0
E1-06	Base Frequency	Hz	72.5	72.5	72.5	72.5	72.5	72.5	72.5	72.5
E1-09	Minimum Output Frequency	Hz	3.6	3.6	3.6	3.6	3.6	3.6	3.6	3.6
C5-17	Motor Inertia	kgm ²	0.0016	0.0022	0.0081	0.0133	0.0133	0.017	0.027	0.044
L3-24 <1>	Motor Acceleration Time for Inertia Calculations	s	0.092	0.068	0.125	0.139	0.083	0.070	0.082	0.092
n5-02	Motor Acceleration Time	s	0.092	0.068	0.125	0.139	0.083	0.070	0.082	0.092
n8-49	d-Axis Current for High Efficiency Control (OLV/PM)	%	-7.5	-9.4	-13.9	-10.0	-15.0	-17.9	-22.7	-20.5

<1> Default setting value varies depending on parameter o2-04, Drive Model Selection.

Table B.33 200 V, 1450 r/min Type Yaskawa SST4 Series IPM Motor

No.	Name	Unit	Default Settings							
E5-01	Motor Code Selection	–	230E	230F	2310	2312	2313	2314	2315	2316
	Voltage Class	V	200	200	200	200	200	200	200	200
	Rated Power	kW	15	18	22	30	37	45	55	75
	Rated Speed	r/min	1450	1450	1450	1450	1450	1450	1450	1450
E5-02	Motor Rated Power	kW	15.0	18.50	22.00	30.00	37.00	45.00	55.00	75.00
E5-03	Motor Rated Current	A	54.2	68.3	75.2	102.0	131.3	160.4	191.7	257.3
E5-04	Number of Motor Poles	–	6	6	6	6	6	6	6	6
E5-05	Motor Stator Resistance (r1)	Ω	0.073	0.055	0.048	0.034	0.023	0.016	0.012	0.007
E5-06	Motor d-Axis Inductance (Ld)	mH	2.94	2.23	2.08	1.67	1.39	0.94	0.82	0.56
E5-07	Motor q-Axis Inductance (Lq)	mH	3.65	2.85	2.66	2.04	1.73	1.22	1.06	0.76
E5-09	Motor Induction Voltage Constant 1 (Ke)	mVs /rad	305.1	297.6	355.8	355.4	324.0	302.4	337.2	323.4
E5-24	Motor Induction Voltage Constant 2 (Ke)	mV/(r/min)	0.0	0.0	0.0	0.0	0.0	0.0	0.0	0.0
E1-04	Maximum Output Frequency	Hz	72.5	72.5	72.5	72.5	72.5	72.5	72.5	72.5
E1-05	Maximum Voltage	V	190.0	190.0	190.0	190.0	190.0	190.0	190.0	190.0
E1-06	Base Frequency	Hz	72.5	72.5	72.5	72.5	72.5	72.5	72.5	72.5
E1-09	Minimum Output Frequency	Hz	3.6	3.6	3.6	3.6	3.6	3.6	3.6	3.6
C5-17	Motor Inertia	kgm ²	0.054	0.063	0.113	0.137	0.252	0.304	0.41	0.55
L3-24 <1>	Motor Acceleration Time for Inertia Calculations	s	0.083	0.079	0.118	0.105	0.157	0.156	0.172	0.169
n5-02	Motor Acceleration Time	s	0.083	0.079	0.118	0.105	0.157	0.156	0.172	0.169
n8-49	d-Axis Current for High Efficiency Control (OLV/PM)	%	-14.6	-16.4	-11.8	-10.5	-14.5	-17.4	-13.9	-17.5

<1> Default setting value varies depending on parameter o2-04, Drive Model Selection.

Table B.34 400 V, 1450 r/min Type Yaskawa SST4 Series IPM Motor

No.	Name	Unit	Default Settings							
E5-01	Motor Code Selection	-	2332	2333	2335	2336	2338	233A	233B	233D
	Voltage Class	V	400	400	400	400	400	400	400	400
	Rated Power	kW	0.4	0.75	1.5	2.2	3.7	5.5	7.5	11
	Rated Speed	r/min	1450	1450	1450	1450	1450	1450	1450	1450
E5-02	Motor Rated Power	kW	0.4	0.75	1.5	2.2	3.7	5.5	7.5	11.0
E5-03	Motor Rated Current	A	0.91	1.67	3.02	4.74	7.08	10.21	13.96	20.5
E5-04	Number of Motor Poles	–	6	6	6	6	6	6	6	6

B.19 Parameters Changed by Motor Code Selection

No.	Name	Unit	Default Settings							
E5-05	Motor Stator Resistance (r1)	Ω	12.616	7.340	2.724	1.232	1.509	1.112	0.720	0.393
E5-06	Motor d-Axis Inductance (Ld)	mH	113.84	77.84	40.00	27.52	31.73	23.09	25.28	13.36
E5-07	Motor q-Axis Inductance (Lq)	mH	157.16	103.56	60.80	37.00	40.88	34.39	35.20	18.44
E5-09	Motor Induction Voltage Constant 1 (Ke)	mVs /rad	490.8	513.8	543.7	520.3	580.8	602.7	601.5	584.6
E5-24	Motor Induction Voltage Constant 2 (Ke)	mV/ (r/min)	0.0	0.0	0.0	0.0	0.0	0.0	0.0	0.0
E1-04	Maximum Output Frequency	Hz	72.5	72.5	72.5	72.5	72.5	72.5	72.5	72.5
E1-05	Maximum Voltage	V	380.0	380.0	380.0	380.0	380.0	380.0	380.0	380.0
E1-06	Base Frequency	Hz	72.5	72.5	72.5	72.5	72.5	72.5	72.5	72.5
E1-09	Minimum Output Frequency	Hz	3.6	3.6	3.6	3.6	3.6	3.6	3.6	3.6
C5-17	Motor Inertia	kgm ²	0.0016	0.0022	0.0081	0.0133	0.0133	0.017	0.027	0.044
L3-24 <1>	Motor Acceleration Time for Inertia Calculations	s	0.092	0.068	0.125	0.139	0.083	0.070	0.082	0.092
n5-02	Motor Acceleration Time	s	0.092	0.068	0.125	0.139	0.083	0.070	0.082	0.092
n8-49	d-Axis Current for High Efficiency Control (OLV/PM)	%	-9.5	-9.4	-13.7	-10.0	-12.9	-19.9	-22.8	-19.8

<1> Default setting value varies depending on parameter o2-04, Drive Model Selection.

Table B.35 400 V, 1450 r/min Type Yaskawa SST4 Series IPM Motor

No.	Name	Unit	Default Settings							
E5-01	Motor Code Selection	-	233E	233F	2340	2342	2343	2344	2345	2346
	Voltage Class	V	400	400	400	400	400	400	400	400
	Rated Power	kW	15	18	22	30	37	45	55	75
	Rated Speed	r/min	1450	1450	1450	1450	1450	1450	1450	1450
E5-02	Motor Rated Power	kW	15	18.50	22.00	30.00	37.00	45.00	55.00	75.00
E5-03	Motor Rated Current	A	27.1	34.2	37.6	50.9	65.4	80.2	96.1	129.2
E5-04	Number of Motor Poles	-	6	6	6	6	6	6	6	6
E5-05	Motor Stator Resistance (r1)	Ω	0.291	0.220	0.192	0.136	0.091	0.064	0.048	0.028
E5-06	Motor d-Axis Inductance (Ld)	mH	11.77	8.94	8.32	6.68	5.30	3.76	3.09	2.24
E5-07	Motor q-Axis Inductance (Lq)	mH	14.60	11.40	10.64	8.16	6.80	4.88	4.75	3.03
E5-09	Motor Induction Voltage Constant 1 (Ke)	mVs /rad	610.3	595.2	711.6	710.8	652.7	604.8	669.1	646.8
E5-24	Motor Induction Voltage Constant 2 (Ke)	mV/ (r/min)	0.0	0.0	0.0	0.0	0.0	0.0	0.0	0.0
E1-04	Maximum Output Frequency	Hz	72.5	72.5	72.5	72.5	72.5	72.5	72.5	72.5
E1-05	Maximum Voltage	V	380.0	380.0	380.0	380.0	380.0	380.0	380.0	380.0
E1-06	Base Frequency	Hz	72.5	72.5	72.5	72.5	72.5	72.5	72.5	72.5
E1-09	Minimum Output Frequency	Hz	3.6	3.6	3.6	3.6	3.6	3.6	3.6	3.6
C5-17	Motor Inertia	kgm ²	0.054	0.063	0.113	0.137	0.252	0.304	0.41	0.55
L3-24 <1>	Motor Acceleration Time for Inertia Calculations	s	0.083	0.079	0.118	0.105	0.157	0.156	0.172	0.169
n5-02	Motor Acceleration Time	s	0.083	0.079	0.118	0.105	0.157	0.156	0.172	0.169
n8-49	d-Axis Current for High Efficiency Control (OLV/PM)	%	-14.5	-16.1	-11.8	-10.5	-15.6	-17.4	-21.7	-17.3

<1> Default setting value varies depending on parameter o2-04, Drive Model Selection.

Table B.36 400 V, 1450 r/min Type Yaskawa SST4 Series IPM Motor

No.	Name	Unit	Default Settings					
E5-01	Motor Code Selection	-	2347	2348	2349	234A	234C	234D
	Voltage Class	V	400	400	400	400	400	400
	Rated Power	kW	90	110	132	160	200	250
	Rated Speed	r/min	1450	1450	1450	1450	1450	1450
E5-02	Motor Rated Power	kW	90.00	110.00	132.00	160.00	200.00	250.00
E5-03	Motor Rated Current	A	153.1	191.7	226.0	268.8	331.3	422.9

B.19 Parameters Changed by Motor Code Selection

No.	Name	Unit	Default Settings					
E5-04	Number of Motor Poles	–	6	6	6	6	6	6
E5-05	Motor Stator Resistance (r1)	Ω	0.024	0.015	0.011	0.007	0.006	0.003
E5-06	Motor d-Axis Inductance (Ld)	mH	2.20	1.34	1.23	0.92	0.84	0.61
E5-07	Motor q-Axis Inductance (Lq)	mH	3.23	2.16	1.67	1.30	1.25	0.89
E5-09	Motor Induction Voltage Constant 1 (Ke)	mVs /rad	708.0	637.8	677.0	661.7	687.1	655.9
E5-24	Motor Induction Voltage Constant 2 (Ke)	mV/ (r/min)	0.0	0.0	0.0	0.0	0.0	0.0
E1-04	Maximum Output Frequency	Hz	72.5	72.5	72.5	72.5	72.5	72.5
E1-05	Maximum Voltage	V	380.0	380.0	380.0	380.0	380.0	380.0
E1-06	Base Frequency	Hz	72.5	72.5	72.5	72.5	72.5	72.5
E1-09	Minimum Output Frequency	Hz	3.6	3.6	3.6	3.6	3.6	3.6
C5-17	Motor Inertia	kgm ²	0.82	0.96	1.60	1.95	2.82	3.70
L3-24 </>	Motor Acceleration Time for Inertia Calculations	s	0.210	0.201	0.279	0.281	0.325	0.341
n5-02	Motor Acceleration Time	s	0.210	0.201	0.279	0.281	0.325	0.341
n8-49	d-Axis Current for High Efficiency Control (OLV/PM)	%	-19.6	-24.1	-15.1	-17.0	-19.8	-19.3

<1> Default setting value varies depending on parameter o2-04, Drive Model Selection.

Table B.37 200 V, 1150 r/min Type Yaskawa SST4 Series IPM Motor

No.	Name	Unit	Default Settings							
E5-01	Motor Code Selection	–	2402	2403	2405	2406	2408	240A	240B	240D
	Voltage Class	V	200	200	200	200	200	200	200	200
	Rated Power	kW	0.4	0.75	1.5	2.2	3.7	5.5	7.5	11
	Rated Speed	r/min	1150	1150	1150	1150	1150	1150	1150	1150
E5-02	Motor Rated Power	kW	0.4	0.75	1.5	2.2	3.7	5.5	7.5	11.0
E5-03	Motor Rated Current	A	1.77	3.44	5.94	9.17	14.79	20.21	27.40	39.0
E5-04	Number of Motor Poles	–	6	6	6	6	6	6	6	6
E5-05	Motor Stator Resistance (r1)	Ω	2.680	1.520	1.071	0.542	0.362	0.295	0.162	0.115
E5-06	Motor d-Axis Inductance (Ld)	mH	30.55	15.29	17.48	11.98	8.60	9.54	5.31	4.44
E5-07	Motor q-Axis Inductance (Lq)	mH	42.71	24.28	22.51	15.51	10.69	13.84	8.26	5.68
E5-09	Motor Induction Voltage Constant 1 (Ke)	mVs /rad	313.1	313.1	345.3	342.9	363.8	384.3	379.9	370.2
E5-24	Motor Induction Voltage Constant 2 (Ke)	mV/ (r/min)	0.0	0.0	0.0	0.0	0.0	0.0	0.0	0.0
E1-04	Maximum Output Frequency	Hz	57.5	57.5	57.5	57.5	57.5	57.5	57.5	57.5
E1-05	Maximum Voltage	V	190.0	190.0	190.0	190.0	190.0	190.0	190.0	190.0
E1-06	Base Frequency	Hz	57.5	57.5	57.5	57.5	57.5	57.5	57.5	57.5
E1-09	Minimum Output Frequency	Hz	2.9	2.9	2.9	2.9	2.9	2.9	2.9	2.9
C5-17	Motor Inertia	kgm ²	0.0022	0.0042	0.0081	0.0133	0.0168	0.027	0.044	0.054
L3-24 </>	Motor Acceleration Time for Inertia Calculations	s	0.080	0.081	0.078	0.088	0.066	0.070	0.085	0.071
n5-02	Motor Acceleration Time	s	0.080	0.081	0.078	0.088	0.066	0.070	0.085	0.071
n8-49	d-Axis Current for High Efficiency Control (OLV/PM)	%	-8.4	-11.0	-10.7	-10.7	-9.4	-22.5	-22.2	-16.7

<1> Default setting value varies depending on parameter o2-04, Drive Model Selection.

Table B.38 200 V, 1150 r/min Type Yaskawa SST4 Series IPM Motor

No.	Name	Unit	Default Settings							
E5-01	Motor Code Selection	–	240E	240F	2410	2412	2413	2414	2415	2416
	Voltage Class	V	200	200	200	200	200	200	200	200
	Rated Power	kW	15	18	22	30	37	45	55	75
	Rated Speed	r/min	1150	1150	1150	1150	1150	1150	1150	1150
E5-02	Motor Rated Power	kW	15	18.50	22.00	30.00	37.00	45.00	55.00	75.00

B.19 Parameters Changed by Motor Code Selection

No.	Name	Unit	Default Settings							
E5-03	Motor Rated Current	A	55.9	65.4	77.0	103.5	126.0	153.1	188.5	260.4
E5-04	Number of Motor Poles	–	6	6	6	6	6	6	6	6
E5-05	Motor Stator Resistance (r1)	Ω	0.083	0.065	0.052	0.035	0.026	0.019	0.013	0.009
E5-06	Motor d-Axis Inductance (Ld)	mH	3.50	2.92	2.55	2.03	1.59	1.24	0.98	0.70
E5-07	Motor q-Axis Inductance (Lq)	mH	4.23	3.79	3.22	2.46	1.92	1.64	1.37	0.97
E5-09	Motor Induction Voltage Constant 1 (Ke)	mVs /rad	364.5	404.5	445.1	444.4	447.3	470.8	422.4	418.3
E5-24	Motor Induction Voltage Constant 2 (Ke)	mV/(r/min)	0.0	0.0	0.0	0.0	0.0	0.0	0.0	0.0
E1-04	Maximum Output Frequency	Hz	57.5	57.5	57.5	57.5	57.5	57.5	57.5	57.5
E1-05	Maximum Voltage	V	190.0	190.0	190.0	190.0	190.0	190.0	190.0	190.0
E1-06	Base Frequency	Hz	57.5	57.5	57.5	57.5	57.5	57.5	57.5	57.5
E1-09	Minimum Output Frequency	Hz	2.9	2.9	2.9	2.9	2.9	2.9	2.9	2.9
C5-17	Motor Inertia	kgm ²	0.063	0.113	0.137	0.252	0.304	0.410	0.55	0.82
L3-24 <1>	Motor Acceleration Time for Inertia Calculations	s	0.061	0.089	0.090	0.122	0.119	0.132	0.145	0.159
n5-02	Motor Acceleration Time	s	0.061	0.089	0.090	0.122	0.119	0.132	0.145	0.159
n8-49	d-Axis Current for High Efficiency Control (OLV/PM)	%	-13.7	-15.2	-10.9	-9.8	-9.3	-11.5	-17.7	-17.1

<1> Default setting value varies depending on parameter o2-04, Drive Model Selection.

Table B.39 400 V, 1150 r/min Type Yaskawa SST4 Series IPM Motor

No.	Name	Unit	Default Settings							
E5-01	Motor Code Selection	–	2432	2433	2435	2436	2438	243A	243B	
	Voltage Class	V	400	400	400	400	400	400	400	
	Rated Power	kW	0.4	0.75	1.5	2.2	3.7	5.5	7.5	
	Rated Speed	r/min	1150	1150	1150	1150	1150	1150	1150	
E5-02	Motor Rated Power	kW	0.4	0.75	1.5	2.2	3.7	5.5	7.5	
E5-03	Motor Rated Current	A	0.89	1.72	3.02	4.58	7.40	10.21	13.75	
E5-04	Number of Motor Poles	–	6	6	6	6	6	6	6	
E5-05	Motor Stator Resistance (r1)	Ω	10.720	6.080	4.336	2.143	1.428	1.199	0.648	
E5-06	Motor d-Axis Inductance (Ld)	mH	122.20	61.16	70.24	46.20	33.87	41.67	21.24	
E5-07	Motor q-Axis Inductance (Lq)	mH	170.80	97.12	90.04	60.28	42.98	69.15	33.04	
E5-09	Motor Induction Voltage Constant 1 (Ke)	mVs /rad	626.1	626.1	703.1	727.6	699.0	861.5	759.7	
E5-24	Motor Induction Voltage Constant 2 (Ke)	mV/(r/min)	0.0	0.0	0.0	0.0	0.0	0.0	0.0	
E1-04	Maximum Output Frequency	Hz	57.5	57.5	57.5	57.5	57.5	57.5	57.5	
E1-05	Maximum Voltage	V	380.0	380.0	380.0	380.0	380.0	380.0	380.0	
E1-06	Base Frequency	Hz	57.5	57.5	57.5	57.5	57.5	57.5	57.5	
E1-09	Minimum Output Frequency	Hz	2.9	2.9	2.9	2.9	2.9	2.9	2.9	
C5-17	Motor Inertia	kgm ²	0.0022	0.0042	0.0081	0.0133	0.0168	0.027	0.044	
L3-24 <1>	Motor Acceleration Time for Inertia Calculations	s	0.080	0.081	0.078	0.088	0.066	0.070	0.085	
n5-02	Motor Acceleration Time	s	0.080	0.081	0.078	0.088	0.066	0.070	0.085	
n8-49	d-Axis Current for High Efficiency Control (OLV/PM)	%	-8.4	-11.0	-9.9	-9.0	-11.4	-23.2	-22.1	

<1> Default setting value varies depending on parameter o2-04, Drive Model Selection.

Table B.40 400 V, 1150 r/min Type Yaskawa SST4 Series IPM Motor

No.	Name	Unit	Default Settings						
E5-01	Motor Code Selection	–	243D	243E	243F	2440	2442	2443	2444
	Voltage Class	V	400	400	400	400	400	400	400
	Rated Power	kW	11	15	18	22	30	37	45
	Rated Speed	r/min	1150	1150	1150	1150	1150	1150	1150

B.19 Parameters Changed by Motor Code Selection

No.	Name	Unit	Default Settings						
E5-02	Motor Rated Power	kW	11.0	15	18.50	22.00	30.00	37.00	45.00
E5-03	Motor Rated Current	A	19.5	27.7	32.7	39.2	51.8	63.0	76.6
E5-04	Number of Motor Poles	–	6	6	6	6	6	6	6
E5-05	Motor Stator Resistance (r1)	Ω	0.460	0.325	0.260	0.209	0.140	0.106	0.076
E5-06	Motor d-Axis Inductance (Ld)	mH	17.76	12.83	11.68	10.09	8.12	6.43	4.96
E5-07	Motor q-Axis Inductance (Lq)	mH	22.72	17.19	15.16	16.25	9.84	7.71	6.56
E5-09	Motor Induction Voltage Constant 1 (Ke)	mVs /rad	740.4	716.6	809.1	786.2	888.8	857.7	941.6
E5-24	Motor Induction Voltage Constant 2 (Ke)	mV/ (r/min)	0.0	0.0	0.0	0.0	0.0	0.0	0.0
E1-04	Maximum Output Frequency	Hz	57.5	57.5	57.5	57.5	57.5	57.5	57.5
E1-05	Maximum Voltage	V	380.0	380.0	380.0	380.0	380.0	380.0	380.0
E1-06	Base Frequency	Hz	57.5	57.5	57.5	57.5	57.5	57.5	57.5
E1-09	Minimum Output Frequency	Hz	2.9	2.9	2.9	2.9	2.9	2.9	2.9
C5-17	Motor Inertia	kgm ²	0.054	0.063	0.113	0.137	0.252	0.304	0.410
L3-24 <1>	Motor Acceleration Time for Inertia Calculations	s	0.071	0.061	0.089	0.090	0.122	0.119	0.132
n5-02	Motor Acceleration Time	s	0.071	0.061	0.089	0.090	0.122	0.119	0.132
n8-49	d-Axis Current for High Efficiency Control (OLV/PM)	%	-16.7	-20.2	-15.2	-27.7	-9.8	-10.2	-11.5

<1> Default setting value varies depending on parameter o2-04, Drive Model Selection.

Table B.41 400 V, 1150 r/min Type Yaskawa SST4 Series IPM Motor

No.	Name	Unit	Default Settings						
E5-01	Motor Code Selection	–	2445	2446	2447	2448	2449	244A	244C
	Voltage Class	V	400	400	400	400	400	400	400
	Rated Power	kW	55	75	90k	110	132	160	200
	Rated Speed	r/min	1150	1150	1150	1150	1150	1150	1150
E5-02	Motor Rated Power	kW	55.00	75.00	90.00	110.00	132.00	160.00	200.00
E5-03	Motor Rated Current	A	93.1	128.1	153.1	186.5	221.9	269.8	336.5
E5-04	Number of Motor Poles	–	6	6	6	6	6	6	6
E5-05	Motor Stator Resistance (r1)	Ω	0.051	0.032	0.026	0.015	0.012	0.009	0.007
E5-06	Motor d-Axis Inductance (Ld)	mH	3.99	2.97	2.44	1.87	1.49	1.41	1.22
E5-07	Motor q-Axis Inductance (Lq)	mH	5.39	3.90	3.23	2.46	2.08	1.88	1.51
E5-09	Motor Induction Voltage Constant 1 (Ke)	mVs /rad	853.8	829.6	835.6	833.4	848.6	889.1	915.0
E5-24	Motor Induction Voltage Constant 2 (Ke)	mV/ (r/min)	0.0	0.0	0.0	0.0	0.0	0.0	0.0
E1-04	Maximum Output Frequency	Hz	57.5	57.5	57.5	57.5	57.5	57.5	57.5
E1-05	Maximum Voltage	V	380.0	380.0	380.0	380.0	380.0	380.0	380.0
E1-06	Base Frequency	Hz	57.5	57.5	57.5	57.5	57.5	57.5	57.5
E1-09	Minimum Output Frequency	Hz	2.9	2.9	2.9	2.9	2.9	2.9	2.9
C5-17	Motor Inertia	kgm ²	0.55	0.82	0.96	1.60	1.95	2.82	3.70
L3-24 <1>	Motor Acceleration Time for Inertia Calculations	s	0.145	0.159	0.155	0.211	0.214	0.256	0.268
n5-02	Motor Acceleration Time	s	0.145	0.159	0.155	0.211	0.214	0.256	0.268
n8-49	d-Axis Current for High Efficiency Control (OLV/PM)	%	-16.0	-15.7	-15.7	-14.7	-16.5	-14.1	-10.4

<1> Default setting value varies depending on parameter o2-04, Drive Model Selection.

This Page Intentionally Blank

Appendix: C

MEMOBUS/Modbus Communications

C.1	MEMOBUS/MODBUS CONFIGURATION.....	612
C.2	COMMUNICATION SPECIFICATIONS.....	613
C.3	CONNECTING TO A NETWORK.....	614
C.4	MEMOBUS/MODBUS SETUP PARAMETERS.....	616
C.5	DRIVE OPERATIONS BY MEMOBUS/MODBUS.....	619
C.6	COMMUNICATIONS TIMING.....	620
C.7	MESSAGE FORMAT.....	621
C.8	MESSAGE EXAMPLES.....	623
C.9	MEMOBUS/MODBUS DATA TABLE.....	625
C.10	ENTER COMMAND.....	641
C.11	COMMUNICATION ERRORS.....	642
C.12	SELF-DIAGNOSTICS.....	643

C.1 MEMOBUS/Modbus Configuration

Drives can be controlled from a PLC or other master device via serial communications using the MEMOBUS/Modbus protocol. MEMOBUS/Modbus communications can be configured using one master (PLC) and up to 255 slaves. The drive has slave functionality only, and serial communication is normally initiated from the master and responded to by the slaves.

The master communicates with the specified slave drive. The address or node for each slave must be set prior so the master can communicate with the slave at that address. A slave that receives a command from the master will perform the specified function and send a response back to the master.

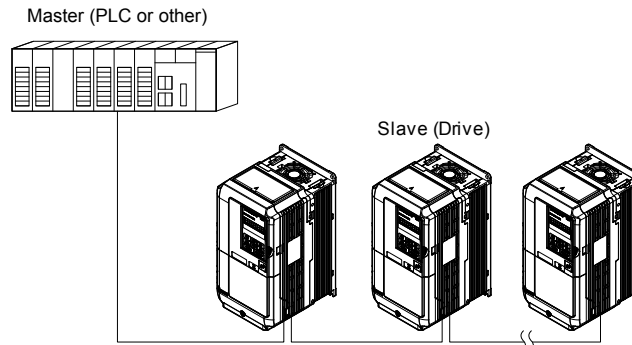

Figure C.1 Connecting Multiple Drives to a PLC

C.2 Communication Specifications

MEMOBUS/Modbus specifications appear in *Table C.1*:

Table C.1 MEMOBUS/Modbus Communications Specifications

Item	Specifications	
Interface	RS-422, RS-485	
Communications Cycle	Asynchronous (Start-stop synchronization)	
Communication Parameters	Communication Speeds Available	1.2; 2.4; 4.8; 9.6; 19.2; 38.4; 57.6; 76.8; 115.2 kbps
	Data length	8-bit (fixed)
	Parity	Select even, odd, or none
	Stop bit	1-bit (fixed)
Protocol	MEMOBUS/Modbus (using RTU mode only)	
Max Number of Slaves	31 drives (RS-485)	

C.3 Connecting to a Network

This section explains how to connect the drive to a MEMOBUS/Modbus network and the network termination required for a connection.

◆ Network Cable Connection

Follow the instructions below to connect the drive to a MEMOBUS/Modbus network.

1. With the power shut off, connect the communications cable to the drive and the master. Use terminals TB5 for MEMOBUS/Modbus.

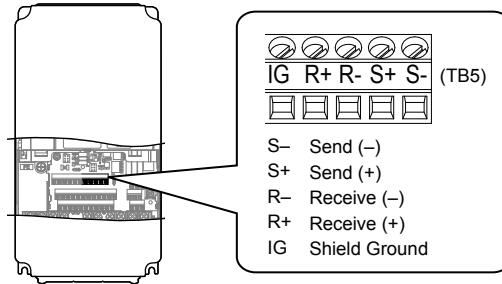

Figure C.2 Serial Communications Cable Connection Terminals (TB5)

Note: Separate the communications cables from the main circuit cables and other wiring and power cables. Use shielded cables for the communications cables, and properly shielded clamps to prevent problems with noise. When using RS-485 communications, connect S+ to R+, and S- to R- as shown in the diagram below.

2. Check or set the termination resistor selection at all slaves. Use the description in [Network Termination](#) on page 615 for slaves that are A1000 drives.
3. Switch the power on.
4. Set the parameters needed for serial communications (H5-01 through H5-12) using the digital operator.
5. Shut the power off and wait until the display on the digital operator goes out completely.
6. Turn the power back on.
7. The drive is now ready to begin communicating with the master.

◆ Wiring Diagram for Multiple Connections

[Figure C.3](#) and [Figure C.4](#) explain the wiring diagrams for multiple connections using MEMOBUS/Modbus communication.

■ RS-485 Interface

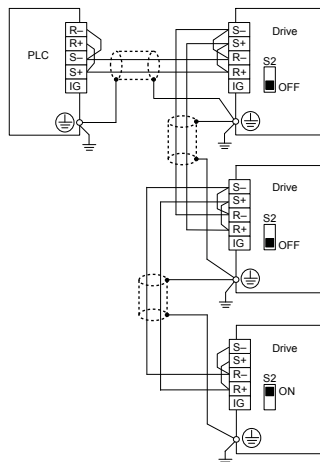

Figure C.3 RS-485 Interface

- Note:**
1. Turn on the DIP switch on the drive that is located at the end of the network. All other slave devices must have this DIP switch set to the OFF position.
 2. Set H5-07 to 1 when using the RS-485 interface.

■ RS-422 Interface

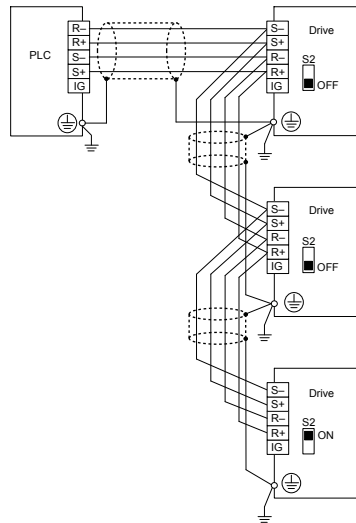

Figure C.4 RS-422 Interface

- Note:**
1. Turn on the DIP switch on the drive that is located at the end of the network. All other slave devices must have this DIP switch set to the OFF position.
 2. Set H5-07 to 0 when using the RS-485 interface.
Set H5-07 to 1 when using the RS-422 interface in a multi-drop circuit. Set H5-07 to 0 when using the RS-422 in a point-to-point circuit.

◆ Network Termination

The two ends of the MEMOBUS/Modbus network line have to be terminated. The drive has a built in termination resistor that can be enabled or disabled using DIP switch S2. If a drive is located at the end of a network line, enable the termination resistor by setting DIP switch S2 to the ON position. Disable the termination resistor on all slaves that are not located at the network line end.

C.4 MEMOBUS/Modbus Setup Parameters

◆ MEMOBUS/Modbus Serial Communication

This section describes parameters necessary to set up MEMOBUS/Modbus communications.

■ H5-01: Drive Slave Address

Sets the drive slave address used for communications.

Note: Cycle the power after changing this parameter to enable the new setting.

No.	Name	Setting Range	Default
H5-01	Drive Slave Address	0 to FFH <1>	1FH

<1> If the address is set to 0, no response will be provided during communications.

Each slave drive must be assigned a unique slave address for serial communications to work. Setting H5-01 to any value besides 0 assigns the drive its address in the network. Slave addresses do not need to be assigned in sequential order, but no two drives may share the same address.

■ H5-02: Communication Speed Selection

Sets the MEMOBUS/Modbus communications speed.

Note: Cycle the power after changing this parameter to enable the new setting.

No.	Name	Setting Range	Default
H5-02	Communication Speed Selection	0 to 5	3

H5-02	Communication Speed	H5-02	Communication Speed
0	1200 bps	5	38400 bps
1	2400 bps	6	57600 bps
2	4800 bps	7	76800 bps
3	9600 bps	8	115200 bps
4	19200 bps		

■ H5-03: Communication Parity Selection

Sets the parity used for communications.

Note: Cycle the power after changing this parameter to enable the new setting.

No.	Name	Setting Range	Default
H5-03	Communication Parity Selection	0 to 2	0

Setting 0: No parity

Setting 1: Even parity

Setting 2: Odd parity

■ H5-04: Stopping Method after Communication Error

Selects the stopping method after a communications error (CE) has occurred.

No.	Name	Setting Range	Default
H5-04	Stopping Method after CE	0 to 3	3

Setting 0: Ramp to stop (uses the deceleration time currently enabled)

Setting 1: Coast to stop

Setting 2: Fast Stop

Setting 3: Alarm only (continue operation)

■ H5-05: Communication Fault Detection Selection

Enables or disables the CE detection for communications.

No.	Name	Setting Range	Default
H5-05	Communication Fault Detection Selection	0 or 1	1

Setting 0: Disabled

No communication error detection. The drive continues operation.

Setting 1: Enabled

If the drive does not receive data from the master for longer than the time set to H5-09, then a CE fault will be triggered and the drive will operate as determined by parameter H5-04.

■ **H5-06: Drive Transmit Wait Time**

Sets the time the drive waits after receiving data from a master until responding data.

No.	Name	Setting Range	Default
H5-06	Drive Transmit Wait Time	5 to 65 ms	5 ms

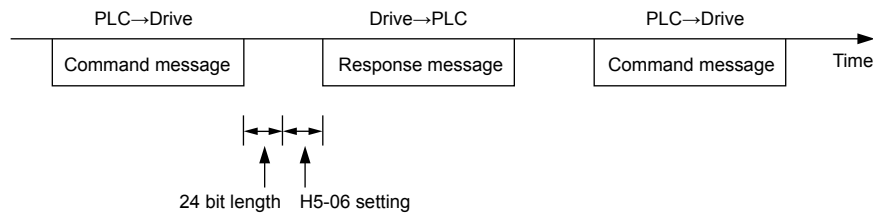

Figure C.5 Drive Transmit Wait Time Setting

■ **H5-07: RTS Control Selection**

Enables or disables RTS control.

No.	Name	Setting Range	Default
H5-07	RTS Control Selection	0 or 1	1

Setting 0: Disabled. RTS is always on.

Use this setting with point-to-point or multi-drop RS-422 communications.

Setting 1: Enabled. RTS switches while sending.

Use this setting when using RS-485 signals for communications or when using the RS-422 signals for point-to-point communications.

■ **H5-09: Communications Fault Detection Time**

Sets the time the communications must be lost before the drive triggers a CE fault.

No.	Name	Setting Range	Default
H5-09	Communications Fault Detection Time	0.0 to 10.0 s	2.0 s

■ **H5-10: Unit Selection for MEMOBUS/Modbus Register 0025H**

Sets the unit for the output voltage monitor value in MEMOBUS/Modbus register 0025H.

No.	Name	Setting Range	Default
H5-10	Unit Selection for MEMOBUS/Modbus Register 0025H	0 or 1	0

Setting 0: 0.1 V units

Setting 1: 1 V units

C.4 MEMOBUS/Modbus Setup Parameters

■ H5-11: Communications Enter Function Selection

Selects whether an Enter command is necessary to change parameter values via MEMOBUS/Modbus communications. *Refer to Enter Command on page 641.*

No.	Name	Setting Range	Default
H5-11	Communications Enter Function Selection	0 or 1	1

Setting 0: Enter command necessary

Parameter changes become effective after an Enter command. An Enter command must only be sent after the last parameter change, not for each single parameter.

Setting 1: Enter command not necessary

Parameter value changes become effective immediately without the need to send an Enter command.

■ H5-12: Run Command Method Selection

Selects the type of sequence used when the Run command source is set to MEMOBUS/Modbus communications (b1-02, b1-16 = 2).

No.	Name	Setting Range	Default
H5-12	Run Command Method Selection	0 or 1	0

Setting 0: FWD/Stop, REV/Stop

Setting bit 0 of MEMOBUS/Modbus register 0001H will start and stop the drive in the forward direction. Setting bit 1 will start and stop the drive in reverse.

Setting 1: Run/Stop, FWD/REV

Setting bit 0 of MEMOBUS/Modbus register 0001H will start and stop the drive. Setting bit 1 changes the direction.

C.5 Drive Operations by MEMOBUS/Modbus

The drive operations that can be performed by MEMOBUS/Modbus communication depend on drive parameter settings. This section explains the functions that can be used and related parameter settings.

◆ Observing the Drive Operation

A PLC can perform the following actions with MEMOBUS/Modbus communications at any time regardless of parameter settings (except for H5-□□parameters):

- observe drive status and drive control terminal status from a PLC.
- read and write parameters.
- set and reset faults.
- set multi-function inputs.

Note: Input settings from the input terminals (S1 to S8) and from MEMOBUS/Modbus communications are both linked by a logical OR operation.

◆ Controlling the Drive

Select an external reference and adjust the parameters in [Table C.2](#) accordingly to start and stop the drive or set the frequency reference using MEMOBUS/Modbus communications.

Table C.2 Setting Parameters for Drive Control from MEMOBUS/Modbus

Reference Source	Parameter	Name	Required Setting
External Reference 1	b1-01	Frequency Reference Selection 1	2
	b1-02	Run Command Selection 1	2
External Reference 2	b1-15	Frequency Reference Selection 2	2
	b1-16	Run Command Selection 2	2

Refer to b1-01: Frequency Reference Selection 1 on page 162 and Refer to b1-02: Run Command Selection 1 on page 163 for details on external reference parameter selections. Refer to Setting 2: External Reference 1/2 Selection on page 249 for instructions on selecting external references 1 and 2.

C.6 Communications Timing

To prevent a communications overrun in the slave drive, the master should wait a certain time between sending messages to the same drive. In the same way, the slave drive must wait before sending response messages to prevent an overrun in the master. This section explains the message timing.

◆ Command Messages from Master to Drive

The master must wait for a specified time between receiving a response and resending the same type of command to the same slave drive to prevent overrun and data loss. The minimum wait time depends on the command as shown in [Table C.3](#).

Table C.3 Minimum Wait Time for Sending Messages

Command Type	Example	Minimum Wait Time
1	<ul style="list-style-type: none"> Control command (Run, Stop) Set inputs/outputs Read monitors and parameter values 	5 ms </>
2	Write parameters	H5-11 = 0: 50 ms H5-11 = 1: 200 ms </>
3	Save changes using an Enter command	200 ms to 2 s, depending on the number of parameters that were changed </>
4	Enter with storage to drive EEPROM after initialization	5 s

<1> If the drive receives command type 1 data during the minimum wait time, it will perform the command and then respond. However, if it receives a command type 2 or 3 during that time, either a communication error will result or the command will be ignored.

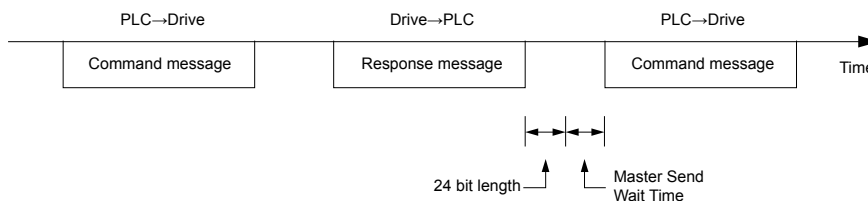

Figure C.6 Minimum Wait Time for Sending Messages

Set a timer in the master to check how long it takes for the slave drive(s) to respond to the master. If no response is received within a certain amount of time, the master should try resending the message.

◆ Response Messages from Drive to Master

If the drive receives a command from the master, it will process the data received and wait for the time set in H5-06 until it responds. Increase H5-06 if the drive response causes overrun in the master.

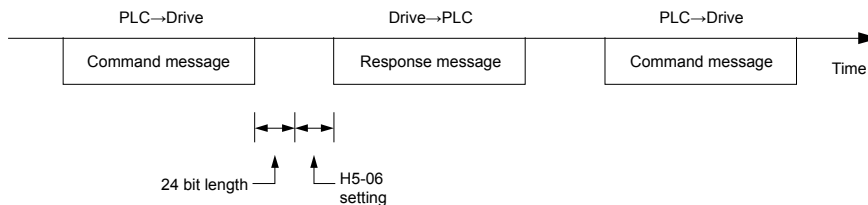

Figure C.7 Minimum Response Wait Time

C.7 Message Format

◆ Message Content

In MEMOBUS/Modbus communications, the master sends commands to the slave, and the slave responds. The message format is configured for both sending and receiving as shown below, and the length of data packets depends on the command (function) content.

SLAVE ADDRESS
FUNCTION CODE
DATA
ERROR CHECK

◆ Slave Address

The slave address in the message defines the note the message is sent to. Use addresses between 0 and FF (hex). If a message with slave address 0 is sent (broadcast), the command from the master will be received by all slaves. The slaves do not provide a response to a broadcast type message.

◆ Function Code

The three types of function codes are shown in the table below.

Function Code	Function Name	Data Length (bytes)			
		Command Message		Response Message	
		Minimum	Maximum	Minimum	Maximum
03H	Read MEMOBUS/Modbus registers	8	8	7	37
08H	Loopback test	8	8	8	8
10H	Write to multiple MEMOBUS/Modbus registers	11	41	8	8

◆ Data

Configure consecutive data by combining the MEMOBUS/Modbus register address (test code in case of a loopback test) and the data the register contains. The data length changes depending on the command details.

A drive MEMOBUS/Modbus register always has a data length of two bytes. Data written into drive registers must also always have a length of two bytes. Register data read out from the drive will always consist of two bytes.

◆ Error Check

The drive uses a CRC-16 (cyclic redundancy check, checksum method) for checking data validity. Use the procedure described below when calculating the CRC-16 checksum for command data or when verifying response data.

■ Command Data

When the drive receives data, it calculates the CRC-16 checksum from the data and compares it to the CRC-16 value received within the message. Both must match before a command is processed.

An initial value of FFFFH (i.e., all 16 bits equal 1) must be used for CRC-16 calculations in the MEMOBUS/Modbus protocol.

Calculate the CRC-16 checksum using the following steps:

1. The starting value is FFFFH.
2. Perform an XOR operation of this value and the slave address.
3. Right shift the result.
4. When the overflow bit of the shift operation becomes 1, perform an XOR operation of the result from step 3 above and the fix value A001H.
5. Repeat steps 3 and 4 until eight shift operations have been performed.
6. After eight shift operations, perform an XOR operation with the result and the next data in the message (function code, register address, data). Continue with steps 3 to 5 until the last data has been processed.
7. The result of the last shift or XOR operation is the checksum.

C.7 Message Format

The example in [Table C.4](#) shows the CRC-16 calculation of the slave address 02H and the function code 03H, yielding the result D140H.

Note: This example does not show the calculation for a complete MEMOBUS/Modbus command. Normally data would follow in the calculation.

Table C.4 CRC-16 Checksum Calculation Example

Description	Calculation	Overflow	Description	Calculation	Overflow	
Initial Value (FFFFH)	1111 1111 1111 1111		Function Code 03H	0000 0000 0000 0011		
Address 02H	0000 0000 0000 0010		XOR w result	1000 0001 0011 1101		
XOR w initial value	1111 1111 1111 1101		Shift 1	0100 0000 1001 1110	1	
Shift 1	0111 1111 1111 1110	1	XOR w A001H	1010 0000 0000 0001		
XOR w A001H	1010 0000 0000 0001		XOR result	1110 0000 1001 1111		
XOR result	1101 1111 1111 1111		Shift 2	0111 0000 0100 1111	1	
Shift 2	0110 1111 1111 1111	1	XOR w A001H	1010 0000 0000 0001		
XOR w A001H	1010 0000 0000 0001		XOR result	1101 0000 0100 1110		
XOR result	1100 1111 1111 1110		Shift 3	0110 1000 0010 0111	0	
Shift 3	0110 0111 1111 1111	0	Shift 4	0011 0100 0001 0011	1	
Shift 4	0011 0011 1111 1111	1	XOR w A001H	1010 0000 0000 0001		
XOR w A001H	1010 0000 0000 0001		XOR result	1001 0100 0001 0010		
XOR result	1001 0011 1111 1110		Shift 5	0100 1010 0000 1001	0	
Shift 5	0100 1001 1111 1111	0	Shift 6	0010 0101 0000 0100	1	
Shift 6	0010 0100 1111 1111	1	XOR w A001H	1010 0000 0000 0001		
XOR w A001H	1010 0000 0000 0001		XOR result	1000 0101 0000 0101		
XOR result	1000 0100 1111 1110		Shift 7	0100 0010 1000 0010	1	
Shift 7	0100 0010 0111 1111	0	XOR w A001H	1010 0000 0000 0001		
Shift 8	0010 0001 0011 1111	1	XOR result	1110 0010 1000 0011		
XOR w A001H	1010 0000 0000 0001		Shift 8	0111 0001 0100 0001	1	
XOR result	1000 0001 0011 1110		XOR w A001H	1010 0000 0000 0001		
Perform operations with next data (function code)			XOR result	1101 0001 0100 0000		
			CRC-16		1101 0001 0100 0000	
					D 1 4 0 (upper) (lower)	
			Continue from here with next data.			

■ Response Data

Perform a CRC-16 calculation on the response message data as described above as a validation check. The result should match the CRC-16 checksum received within the response message.

C.8 Message Examples

Below are some examples of command and response messages.

◆ Reading Drive MEMOBUS/Modbus Register Contents

Using the function code 03H (Read), a maximum of 16 MEMOBUS/Modbus registers can be read out at a time.

The following table shows message examples when reading status signals, error details, data link status, and frequency references from the slave 2 drive.

Command Message			Response Message (normal)			Response Message (fault)		
Slave Address		02H	Slave Address		02H	Slave Address		02H
Function Code		03H	Function Code		03H	Function Code		83H
Starting No.	Upper	00H	Data Quantity		08H	Error Code		03H
	Lower	20H	1st storage register	Upper	00H	CRC-16	Upper	F1H
Data Quantity	Upper	00H		Lower	65H		Lower	31H
	CRC-16	Lower	04H	Next storage register	Upper	00H		
Upper		45H	Lower		00H			
CRC-16	Lower	F0H	Next storage register	Upper	00H			
				Lower	00H			
			Next storage register	Upper	01H			
				Lower	F4H			
			CRC-16	Upper	AFH			
				Lower	82H			

◆ Loopback Test

Function code 08H performs a loopback test that returns a response message with exactly the same content as the command message. The response message can be used to check communications between the master and slave. User-defined test code and data values can also be set.

The following table shows a message example when performing a loopback test with the slave 1 drive.

Command Message			Response Message (normal)			Response Message (fault)		
Slave Address		01H	Slave Address		01H	Slave Address		01H
Function Code		08H	Function Code		08H	Function Code		88H
Test Code	Upper	00H	Test Code	Upper	00H	Error Code		01H
	Lower	00H		Lower	00H	CRC-16	Upper	86H
Data	Upper	A5H	Data	Upper	A5H		Lower	50H
	Lower	37H		Lower	37H			
CRC-16	Upper	DAH	CRC-16	Upper	DAH			
	Lower	8DH		Lower	8DH			

◆ Writing to Multiple Registers

Function code 10H allows the user to write multiple drive MEMOBUS/Modbus registers with one message. This process works similar to reading registers, in that the address of the first register to be written and the data quantity are set in the command message. The data to be written must be consecutive so that the register addresses are in order, starting from the specified address in the command message. The data order must be high byte then lower byte.

The following table shows an example of a message where a forward operation has been set with a frequency reference of 60.0 Hz for the slave 1 drive.

If parameter values are changed using the Write command, an Enter command may be necessary to activate or save the data depending on the setting of H5-11. *Refer to H5-11: Communications Enter Function Selection on page 618* and *Refer to Enter Command on page 641* for detailed descriptions.

Command Message			Response Message (normal)			Response Message (fault)		
Slave Address		01H	Slave Address		01H	Slave Address		01H
Function Code		10H	Function Code		10H	Function Code		90H
Starting No.	Upper	00H	Starting No.	Upper	00H	Error Code		02H
	Lower	01H		Lower	01H	CRC-16	Upper	CDH
Data Quantity	Upper	00H	Data Quantity	Upper	00H		Lower	C1H
	Lower	02H		Lower	02H			
Number of Bytes		04H	CRC-16	Upper	10H			
Starting Data	Upper	00H		Lower	08H			
	Lower	01H						
Next Data	Upper	02H						
	Lower	58H						
CRC-16	Upper	63H						
	Lower	39H						

Note: Double the number of the data quantity for the number of bytes in the command message.

C.9 MEMOBUS/Modbus Data Table

The table below lists all MEMOBUS/Modbus data. There are three types of data: command data, monitor data, and broadcast data.

◆ Command Data

It is possible to both read and write command data.

Note: Bits that are not used should be set to 0. Refrain from writing to reserved registers.

Register No.	Contents	
0000H	Reserved	
0001H	Operation Commands and Multi-function Inputs	
	bit 0	H5-12 = 0: Forward Run Command (0 = Stop, 1 = Forward Run) H5-12 = 1: Run Command (0 = Stop, 1 = Run)
	bit 1	H5-12 = 0: Reverse Run Command (0 = Stop, 1 = Reverse Run) H5-12 = 1: Forward/Reverse (0 = Forward, 1 = Reverse)
	bit 2	External Fault (EF0)
	bit 3	Fault Reset
	bit 4	Multi-Function Input 1 Function is ComRef when H1-01 = 40 (Forward/Stop). <i>Refer to d: Reference Settings on page 208</i> for ComRef explanations.
	bit 5	Multi-Function Input 2 Function is ComCtrl when H1-02 = 41 (Reverse/Stop).
	bit 6	Multi-Function Input 3
	bit 7	Multi-Function Input 4
	bit 8	Multi-Function Input 5
	bit 9	Multi-Function Input 6
	bit A	Multi-Function Input 7
	bit B	Multi-Function Input 8
	bit C to F	Reserved
0002H	Frequency Reference	Units are determined by parameter o1-03.
0003H	Output voltage gain/ Unit: 0.1% Range: 20 (2.0%) to 2000 (200.0%), Default when power on: 1000 (100.0%)	
0004H	Torque Reference/Torque Limit, 0.1% units, signed (Usable only if Torque Control is enabled)	
0005H	Torque Compensation, 0.1% units, signed (Usable only if Torque Control is enabled)	
0006H	PID Target, 0.01% units, signed	
0007H	Analog Output Terminal FM Setting (10 V / 4000 H)	
0008H	Analog Output Terminal AM Setting (10 V / 4000 H)	
0009H	Settings for Multi-Function Digital Outputs	
	bit 0	Multi-Function Contact Output 1 (terminal M1-M2)
	bit 1	Multi-Function Contact Output 2 (terminal M3-M4)
	bit 2	Multi-Function Contact Output 3 (terminal M5-M6)
	bit 3 to 5	Reserved
	bit 6	Enables the function in bit 7
	bit 7	Fault Contact Output (terminal MA/MB-MC)
bit 8 to F	Reserved	
000AH	Pulse Output Terminal MP Setting, 1 Hz units, Setting Range: 0 to 32000	
000BH to 000EH	Reserved	

C.9 MEMOBUS/Modbus Data Table

Register No.	Contents	
000FH	Control Selection Setting	
	bit 0	Reserved
	bit 1	PID Setpoint Input
	bit 2	Torque reference / torque limit input (enables the setting from MEMOBUS/Modbus)
	bit 3	Torque compensation input (enables the setting from MEMOBUS/Modbus)
	bit 4 to B	Reserved
	bit C	Enable Terminal S5 Input for Broadcast Data
	bit D	Enable Terminal S6 Input for Broadcast Data
	bit E	Enable Terminal S7 Input for Broadcast Data
bit F	Enable Terminal S8 Input for Broadcast Data	
0010H to 001AH	Reserved	
001BH	Analog Monitor Option AO-A3 Analog Output 1 (10 V/4000 H)	
001CH	Analog Monitor Option AO-A3 Analog Output 2 (10 V/4000 H)	
001DH	Digital Output Option DO-A3 Output (Binary)	
001EH to 001FH	Reserved	

◆ Monitor Data

Monitor data can be read only.

Register No.	Contents	
0020H	Drive Status 1	
	bit 0	During Run
	bit 1	During Reverse
	bit 2	Drive Ready
	bit 3	Fault
	bit 4	Data Setting Error
	bit 5	Multi-Function Contact Output (terminal M1-M2)
	bit 6	
	bit 7	
	bit 8 to bit D	Reserved
	bit E	ComRef status
bit F	ComCtrl status	
0021H	Fault Contents 1	
	bit 0	Overcurrent (oC), Ground fault (GF)
	bit 1	Overvoltage (ov)
	bit 2	Drive Overload (oL2)
	bit 3	Overheat 1 (oH1), Drive Overheat Warning (oH2)
	bit 4	Dynamic Braking Transistor Fault (rr), Braking Resistor Overheat (rH)
	bit 5	Reserved
	bit 6	PID Feedback Loss (FbL / FbH)
	bit 7	EF to EF8: External Fault
	bit 8	CPF□□: Hardware Fault (includes oFx)
	bit 9	Motor Overload (oL1), Overtorque Detection 1/2 (oL3/oL4), Undertorque Detection 1/2 (UL3/UL4)
	bit A	PG Disconnected (PGo), PG Hardware Fault (PGoH), Overspeed (oS), Excessive Speed Deviation (dEv)
	bit B	Main Circuit Undervoltage (Uv)
	bit C	Undervoltage (Uv1), Control Power Supply Undervoltage (Uv2), Soft Charge Circuit Fault (Uv3)
	bit D	Output Phase Loss (LF), Input Phase Loss (PF)
bit E	MEMOBUS/Modbus Communication Error (CE), Option Communication Error (bUS)	
bit F	Operator Connection Fault (oPr)	

Register No.	Contents	
0022H	Data Link Status	
	bit 0	Writing data or switching motors
	bit 1	Reserved
	bit 2	
	bit 3	Upper or lower limit error
	bit 4	Data conformity error
	bit 5	Writing to EEPROM
	bit 6 to bit F	Reserved
0023H	Frequency Reference </>	
0024H	Output Frequency </>	
0025H	Output Voltage Reference, 0.1 V units (units are determined by parameter H5-10)	
0026H	Output Current, 0.1 A units	
0027H	Output Power	
0028H	Torque Reference	
0029H	Fault Contents 2	
	bit 0	IGBT Short Circuit (SC)
	bit 1	Ground Fault (GF)
	bit 2	Input Phase Loss (PF)
	bit 3	Output Phase Loss (LF)
	bit 4	Braking Resistor Overheat (rH)
	bit 5	Reserved
	bit 6	Motor Overheat 2 (PTC input) (oH4)
bit 7 to bit F	Reserved	
002AH	Alarm Contents 1	
	bit 0, 1	Reserved
	bit 2	Run Command Input Error (EF)
	bit 3	Drive Baseblock (bb)
	bit 4	Overtorque Detection 1 (oL3)
	bit 5	Heatsink Overheat (oH)
	bit 6	Overvoltage (ov)
	bit 7	Undervoltage (Uv)
	bit 8	Cooling Fan Error (FAn)
	bit 9	MEMOBUS/Modbus Communication Error (CE)
	bit A	Option Communication Error (bUS)
	bit B	Undertorque Detection 1/2 (UL3/UL4)
	bit C	Motor Overheat (oH3)
	bit D	PID Feedback Loss (FbL, FbH)
	bit E	Reserved
bit F	Serial Communication Transmission Error (CALL)	
002BH	Input Terminal Status	
	bit 0	Terminal S1 Closed
	bit 1	Terminal S2 Closed
	bit 2	Terminal S3 Closed
	bit 3	Terminal S4 Closed
	bit 4	Terminal S5 Closed
	bit 5	Terminal S6 Closed
	bit 6	Terminal S7 Closed
	bit 7	Terminal S8 Closed
bit 8 to bit F	Reserved	

C.9 MEMOBUS/Modbus Data Table

Register No.	Contents	
002CH	Drive Status 2	
	bit 0	During Run
	bit 1	Zero Speed
	bit 2	Speed Agree
	bit 3	User Speed Agree
	bit 4	Frequency Detection 1
	bit 5	Frequency Detection 2
	bit 6	Drive Ready
	bit 7	During Undervoltage
	bit 8	During Baseblock
	bit 9	Frequency Reference from Operator Keypad
	bit A	Run Command from Operator Keypad
	bit B	Over/Undertorque 1, 2
	bit C	Frequency Reference Loss
	bit D	During Fault Restart
	bit E	Fault
bit F	Communication Timeout	
002DH	Output Terminal Status	
	bit 0	Multi-Function Contact Output 1 (terminal M1-M2)
	bit 1	
	bit 2	
	bit 3 to 6	Reserved
	bit 7	Fault Contact Output (terminal MA/MB-MC)
	bit 8 to F	Reserved
002EH	Reserved	
002FH	Frequency Reference Bias (from Up/Down 2 Function), 0.1% units	
0030H	Reserved	
0031H	DC Bus Voltage, 1 Vdc units	
0032H	Torque Reference (U1-09), 1% units	
0033H	Reserved	
0034H	Product Code 1 [ASCII], Product Type (A0 for A1000)	
0035H	Product Code 2 [ASCII], Region Code	
0036H, 0037H	Reserved	
0038H	PID Feedback, 0.1% units, unsigned, 100% / max. output frequency	
0039H	PID Input, 0.1% units, signed, 100% / max. output frequency	
003AH	PID Output, 0.1% units, signed, 100% / max. output frequency	
003BH, 003CH	Reserved	
003DH	Communications Error Contents <3>	
	bit 0	CRC Error
	bit 1	Data Length Error
	bit 2	Reserved
	bit 3	Parity Error
	bit 4	Overrun Error
	bit 5	Framing Error
	bit 6	Timeout
bit 7 to bit F	Reserved	
003EH	Output Frequency	r/min <4>
003FH		0.01% units
0040H to 004AH	Used for various monitors U1-□□. Refer to U: Monitors on page 562 for parameter details.	

Register No.	Contents	
004BH	Drive status (U1-12)	
	bit 0	During Run
	bit 1	During Zero Speed
	bit 2	During Reverse Run
	bit 3	During Fault Reset Signal Input
	bit 4	During Speed Agree
	bit 5	Drive Ready
	bit 6	Alarm
	bit 7	Fault
	bit 8	During Operation Error (oPE□□)
	bit 9	During Momentary Power Loss
	bit A	Motor 2 selected
	bit B	Reserved
	bit E	ComRef status, NetRef status
bit F	ComCtrl status, NetCtrl status	
004CH to 007EH	Used for various monitors U1-□□, U4-□□, U5-□□ and U6-□□. <i>Refer to U2: Fault Trace on page 564</i> and <i>Refer to U3: Fault History on page 566</i> for parameter details.	
007FH	Alarm Code, <i>Refer to Alarm Register Contents on page 640</i> for alarm codes.	
0080H to 0097H	Used for monitors U2-□□, U3-□□. <i>Refer to U: Monitors on page 562</i> for parameter details and <i>Refer to Fault Trace Contents on page 638</i> for register value descriptions.	
0098H	High Word of Accumulated Operation Time Monitor, 10 h units (U4-01)	
0099H	Low Word of Accumulated Operation Time Monitor, 1 h units (U4-01)	
009AH	High Word of Cooling Fan Operation Time Monitor (U4-03)	
009BH	Low Word of Cooling Fan Operation Time Monitor (U4-03)	
009CH to 00AAH	Reserved	
00ABH	Drive Rated Current <=>	
00ACH	Motor Speed (U1-05)	r/min units <=>
00ADH		0.01% units
00AEH, 00AFH	Reserved	
00B0H	Option Code Connected to CN5-A	Register contains ASCII code of the option card. DI-A3 = 0001H DO-A3 = 0002H AI-A3 = 0003H AO-A3 = 0004H PG-B3 = 0011H PG-X3 = 0012H PG-RT3 = 0023H Communication Option: Register contains ASCII code of first and third digit of the option card type number. Example: Register value is 5343H for “SC” if an SI-C3 option card is installed.
00B1H	Reserved	
00B2H	Option Code Connected to CN5-B	
00B3H	Option Code Connected to CN5-C	
00B4H	Reserved	
00B5H	Frequency Reference After Soft-starter (U1-16)	r/min units <=>
00B6H		0.01% units
00B7H	Frequency Reference	r/min <=>
00B8H		0.01% units
00B9H to 00BEH	Reserved	
00BFH	Lists the last two digits of operation error code oPE□□.	

C.9 MEMOBUS/Modbus Data Table

Register No.	Contents	
00C0H	Fault Contents 3	
	bit 1	Undervoltage (Uv1)
	bit 2	Control Power Supply Undervoltage (Uv2)
	bit 3	Soft Charge Circuit Fault (Uv3)
	bit 4	IGBT Short Circuit (SC)
	bit 5	Ground Fault (GF)
	bit 6	Overcurrent (oC)
	bit 7	Overvoltage (ov)
	bit 8	Heatsink Overheat (oH)
	bit 9	Heatsink Overheat (oH1)
	bit A	Motor Overload (oL1)
	bit B	Drive Overload (oL2)
	bit C	Overtorque Detection 1 (oL3)
	bit D	Overtorque Detection 2 (oL4)
	bit E	Dynamic Braking Transistor Fault (rr)
bit F	Braking Resistor Overheat (rH)	
00C1H	Fault Contents 4	
	bit 0	External Fault at input terminal S3 (EF3)
	bit 1	External Fault at input terminal S4 (EF4)
	bit 2	External Fault at input terminal S5 (EF5)
	bit 3	External Fault at input terminal S6 (EF6)
	bit 4	External Fault at input terminal S7 (EF7)
	bit 5	External Fault at input terminal S8 (EF8)
	bit 6	Cooling Fan Error (FAn)
	bit 7	Overspeed (os)
	bit 8	Excessive Speed Deviation (dEv)
	bit 9	PG Disconnected (PGo)
	bit A	Input Phase Loss (PF)
	bit B	Output Phase Loss (LF)
	bit C	Motor Overheat (PTC input) (oH3)
	bit D	Digital Operator Connection Fault (oPr)
bit E	EEPROM Write Error (Err)	
bit F	Motor Overheat Fault (PTC input) (oH4)	
00C2H	Fault Contents 5	
	bit 0	MEMOBUS/Modbus Communication Error (CE)
	bit 1	Option Communication Error (bUS)
	bit 2, 3	Reserved
	bit 4	Control Fault (CF)
	bit 5	Zero Servo Fault (SvE)
	bit 6	Option External Fault (EF0)
	bit 7	PID Feedback Loss (FbL)
	bit 8	Undertorque Detection 1 (UL3)
	bit 9	Undertorque Detection 2 (UL4)
	bit A	High Slip Braking Overload (oL7)
	bit B to E	Reserved
bit F	Hardware Fault (includes oFx)	

Register No.	Contents	
00C3H	Fault Contents 6	
	bit 0	Reserved
	bit 1	Z Pulse Fall Detection (dv1)
	bit 2	Z Pulse Noise Fault Detection (dv2)
	bit 3	Inversion Detection (dv3)
	bit 4	Inversion Prevention Detection (dv4)
	bit 5	Current Imbalance (LF2)
	bit 6	Pullout Detection (STo)
	bit 7	PG Hardware Fault (PGoH)
	bit 8	SI-T3 Watchdog Error (E5)
	bit 9	Reserved
	bit A	Too many speed search restarts (SEr)
bit B to F	Reserved	
00C4H	Fault Contents 7	
	bit 0	PID Feedback Loss (FbH)
	bit 1	External Fault 1, input terminal S1 (EF1)
	bit 2	External Fault 2, input terminal S2 (EF2)
	bit 3	Mechanical Weakening Detection 1 (oL5)
	bit 4	Mechanical Weakening Detection 2 (UL5)
	bit 5	Current Offset Fault (CoF)
	bit 6, 7	Reserved
	bit 8	DriveWorksEZ Fault (dWFL)
	bit 9 to B	Reserved
	bit C	Output Voltage Detection Fault (voF)
	bit D	Braking Resistor Fault (rF)
	bit E	Braking Transistor Overload Fault (boL)
bit F	Motor Overheat (NTC Input) (oH5)	
00C5H	Fault Contents 8	
	bit 0	Reserved
	bit 1	Node Setup Fault (nSE)
	bit 2	Thermistor Disconnect (THo)
	bit 3 to 9	Reserved
	bit A	Polarity Judge Timeout (dv7)
	bit B to D	Reserved
	bit E	Power Unit Output Phase Loss 3 (LF3)
bit F	Current Unbalance (UnbC)	
00C6H	Fault Contents 9	
	bit 0	Gate Drive Board Undervoltage (Uv4)
	bit 1 to F	Reserved
00C7H	Reserved	

C.9 MEMOBUS/Modbus Data Table

Register No.	Contents	
00C8H	Alarm Contents 2	
	bit 0	Undervoltage (Uv)
	bit 1	Overvoltage (ov)
	bit 2	Heatsink Overheat (oH)
	bit 3	Drive Overheat (oH2)
	bit 4	Overtorque 1 (oL3)
	bit 5	Overtorque 2 (oL4)
	bit 6	Run Commands Input Error (EF)
	bit 7	Drive Baseblock (bb)
	bit 8	External Fault 3, input terminal S3 (EF3)
	bit 9	External Fault 4, input terminal S4 (EF4)
	bit A	External Fault 5, input terminal S5 (EF5)
	bit B	External Fault 6, input terminal S6 (EF6)
	bit C	External Fault 7, input terminal S7 (EF7)
	bit D	External Fault 8, input terminal S8 (EF8)
	bit E	Cooling Fan Error (FAn)
bit F	Overspeed (oS)	
00C9H	Alarm Contents 3	
	bit 0	Excessive Speed Deviation (dEv)
	bit 1	PG Disconnected (PGo)
	bit 2	Digital Operator Connection Fault (oPr)
	bit 3	MEMOBUS/Modbus Communication Error (CE)
	bit 4	Option Communication Error (bUS)
	bit 5	Serial Communication Transmission Error (CALL)
	bit 6	Motor Overload (oL1)
	bit 7	Drive Overload (oL2)
	bit 8	Reserved
	bit 9	Option Card External fault (EF0)
	bit A	Motor 2 Switch command input during run (rUn)
	bit B	Reserved
	bit C	Serial Communication Transmission Error (CALL)
	bit D	Undertorque Detection 1 (UL3)
	bit E	Undertorque Detection 2 (UL4)
bit F	MEMOBUS/Modbus Test Mode Fault (SE)	
00CAH	Alarm Contents 4	
	bit 0	Reserved
	bit 1	Motor Overheat 1 (PTC Input) (oH3)
	bit 2 to 5	Reserved
	bit 6	PID Feedback Loss (FbL)
	bit 7	PID Feedback Loss (FbH)
	bit 9	Drive Disabled (dnE)
	bit A	PG Disconnected (PGo)
bit B to F	Reserved	

Register No.	Contents	
00CBH	Alarm Contents 5	
	bit 0	SI-T3 Watchdog Error (E5)
	bit 1	SI-T3 Station Address Setting Error (AEr)
	bit 2	SI-T3 Comm. Cycle Setting Error (CyC)
	bit 3	High Current Alarm (HCA)
	bit 4	Cooling Fan Maintenance Time (LT-1)
	bit 5	Soft Charge Bypass Relay Maintenance Time (LT-2)
	bit 6	Reserved
	bit 7	SI-S EEPROM Error (EEP)
	bit 8	External Fault 1 (input terminal S1) (EF1)
	bit 9	External Fault 2 (input terminal S2) (EF2)
	bit A	Safe Disable Input (HbbF) <>
	bit B	Safe Disable Input (Hbb) <>
	bit C	Mechanical Weakening Detection 1 (oL5)
	bit D	Mechanical Weakening Detection 2 (UL5)
bit E, F	Reserved	
00CCH	Alarm Contents 6	
	bit 0	Output Voltage Detection Fault (VoF)
	bit 1	IGBT Maintenance Time (90%) (TrPC)
	bit 2	Capacitor Maintenance Time (LT-3)
	bit 3	IGBT Maintenance Time (50%) (LT-4)
	bit 4	Braking Transistor Overload Fault (boL)
	bit 5 to 6	Reserved
	bit 7	Motor Overheat (NTC Input) (oH5)
	bit 8	DriveWorksEZ Alarm (dWAL)
	bit 9 to B	Reserved
	bit C	Thermistor Disconnect (THo)
bit D to F	Reserved	
00CDH to 00CFH	Reserved	
00D0H	CPF Contents 1	
	bit 0, 1	Reserved
	bit 2	A/D Conversion Error (CPF02)
	bit 3	PWM Data Fault (CPF03)
	bit 4, 5	Reserved
	bit 6	EEPROM Memory Data Error (CPF06)
	bit 7	Terminal Board Connection Error (CPF07)
	bit 8	EEPROM Serial Communications Fault (CPF08)
	bit 9, A	Reserved
	bit B	RAM Fault (CPF11)
	bit C	FLASH Memory Fault (CPF12)
	bit D	Watchdog Circuit Exception (CPF13)
bit E	Control Circuit Fault (CPF14)	
bit F	Reserved	

C.9 MEMOBUS/Modbus Data Table

Register No.	Contents	
00D1H	CPF Contents 2	
	bit 0	Clock Fault (CPF16)
	bit 1	Timing Fault (CPF17)
	bit 2	Control Circuit Fault (CPF18)
	bit 3	Control Circuit Fault (CPF19)
	bit 4	Hardware fault at power up (CPF20)
	bit 5	Hardware fault at communication start up (CPF21)
	bit 6	A/D Conversion Fault (CPF22)
	bit 7	PWM Feedback Fault (CPF23)
	bit 8	Drive Unit Signal Fault (CPF24)
	bit 9	Terminal board is not properly connected. (CPF25)
	bit A	ASIC BB Circuit Error (CPF26)
	bit B	ASIC PWM Setting Register Error (CPF27)
	bit C	ASIC PWM Pattern Error (CPF28)
	bit D	ASIC On-delay Error (CPF29)
	bit E	ASIC BBON Error (CPF30)
bit F	ASIC Code Error (CPF31)	
00D2H	bit 0	ASIC Start-up Error (CPF32)
	bit 1	Watch-dog Error (CPF33)
	bit 2	ASIC Power/Clock Error (CPF34)
	bit 3	External A/D Converter Error (CPF35)
	bit 4 to 7	Reserved
	bit 8	Control Circuit Error (CPF40)
	bit 9	Control Circuit Error (CPF41)
	bit A	Control Circuit Error (CPF42)
	bit B	Control Circuit Error (CPF43)
	bit C	Control Circuit Error (CPF44)
	bit D	Control Circuit Error (CPF45)
	bit E, F	Reserved
00D3H to 00D7H	oFA0x Contents (CN5-A)	
00D8H	oFA0x Contents (CN5-A)	
	bit 0	Option Compatibility Error (oFA00)
	bit 1	Option not properly connected (oFA01)
	bit 2	Same type of option card already connected (oFA02)
	bit 3, 4	Reserved
	bit 5	A/D Conversion Error (oFA05)
	bit 6	Option Response Error (oFA06)
	bit 7 to F	Reserved
00D9H	oFA1x Contents (CN5-A)	
	bit 0	Option RAM Fault (oFA10)
	bit 1	Option Operation Mode Fault (SLMOD) (oFA11)
	bit 2	Drive Receive CRC Error (oFA12)
	bit 3	Drive Receive Frame Error (oFA13)
	bit 4	Drive Receive Abort Error (oFA14)
	bit 5	Option Receive CRC Error (oFA15)
	bit 6	Option Receive Frame Error (oFA16)
	bit 7	Option Receive Abort Error (oFA17)
bit 8 to F	Reserved	
00DAH to 00DBH	Reserved	

Register No.	Contents	
00DBH	oFA3x Contents (CN5-A)	
	bit 0	Comm. ID Error (oFA30)
	bit 1	Model Code Error (oFA31)
	bit 2	Sumcheck Error (oFA32)
	bit 3	Comm. option timeout waiting for response (oFA33)
	bit 4	MEMOBUS Timeout (oFA34)
	bit 5	Drive timeout waiting for response (oFA35)
	bit 6	CI Check Error (oFA36)
	bit 7	Drive timeout waiting for response (oFA37)
	bit 8	Control Command Selection Error (oFA38)
	bit 9	Drive timeout waiting for response (oFA39)
	bit A	Control Response Selection 1 Error (oFA40)
	bit B	Drive timeout waiting for response (oFA41)
	bit C	Control Response Selection 2 Error (oFA42)
	bit D	Control Response Selection Error (oFA43)
bit E, F	Reserved	
00DCH	oFb0x Contents (CN5-B)	
	bit 0	Option compatibility error (oFb00)
	bit 1	Option not properly connected (oFb01)
	bit 2	Same type of option card already connected (oFb02)
	bit 3, 4	Reserved
	bit 5	A/D Conversion Fault (oFb05)
	bit 6	Option Response Error (oFb06)
bit 7 to F	Reserved	
00DDH	oFb1x Contents (CN5-B)	
	bit 0	Option RAM Fault (oFb10)
	bit 1	Option Operation Mode Fault (SLMOD) (oFb11)
	bit 2	Drive Receive CRC Error (oFb12)
	bit 3	Drive Receive Frame Error (oFb13)
	bit 4	Drive Receive Abort Error (oFb14)
	bit 5	Option Receive CRC Error (oFb15)
	bit 6	Option Receive Frame Error (oFb16)
bit 7	Option Receive Abort Error (oFb17)	
bit 8 to F	Reserved	
00DEH to 00DFH	Reserved	

C.9 MEMOBUS/Modbus Data Table

Register No.	Contents	
00E0H	oFb3x Contents (CN5-B)	
	bit 0	Comm. ID Error (oFb30)
	bit 1	Model Code Error (oFb31)
	bit 2	Sumcheck Error (oFb32)
	bit 3	Comm. option timeout waiting for response (oFb33)
	bit 4	MEMOBUS Timeout (oFb34)
	bit 5	Drive timeout waiting for response (oFb35)
	bit 6	CI Check Error (oFb36)
	bit 7	Drive timeout waiting for response (oFb37)
	bit 8	Control Command Selection Error (oFb38)
	bit 9	Drive timeout waiting for response (oFb39)
	bit A	Control Response Selection 1 Error (oFb40)
	bit B	Drive timeout waiting for response (oFb41)
	bit C	Control Response Selection 2 Error (oFb42)
	bit D	Control Response Selection Error (oFb43)
bit E, F	Reserved	
00E1H	oFC0x Contents (CN5-C)	
	bit 0	Option compatibility error (oFC00)
	bit 1	Option not properly connected (oFC01)
	bit 2	Same type of option card already connected (oFC02)
	bit 3, 4	Reserved
	bit 5	A/D Conversion Fault (oFC05)
	bit 6	Option Response Error (oFC06)
	bit 7 to F	Reserved
00E2H	oFC1x Contents (CN5-C)	
	bit 0	Option RAM Fault (oFC10)
	bit 1	Option Operation Mode Fault (SLMOD) (oFC11)
	bit 2	Drive Receive CRC Error (oFC12)
	bit 3	Drive Receive Frame Error (oFC13)
	bit 4	Drive Receive Abort Error (oFC14)
	bit 5	Option Receive CRC Error (oFC15)
	bit 6	Option Receive Frame Error (oFC16)
	bit 7	Option Receive Abort Error (oFC17)
bit 8 to F	Reserved	
00E3H, 00E4H	Reserved	

Register No.	Contents	
00E5H	oFC3x Contents (CN5-C)	
	bit 0	Comm. ID Error (oFC30)
	bit 1	Model Code Error (oFC31)
	bit 2	Sumcheck Error (oFC32)
	bit 3	Comm. option timeout waiting for response (oFC33)
	bit 4	MEMOBUS Timeout (oFC34)
	bit 5	Drive timeout waiting for response (oFC35)
	bit 6	CI Check Error (oFC36)
	bit 7	Drive timeout waiting for response (oFC37)
	bit 8	Control Command Selection Error (oFC38)
	bit 9	Drive timeout waiting for response (oFC39)
	bit A	Control Response Selection 1 Error (oFC40)
	bit B	Drive timeout waiting for response (oFC41)
	bit C	Control Response Selection 2 Error (oFC42)
	bit D	Control Response Selection Error (oFC43)
bit E, F	Reserved	
00E6H to 00FFH	Reserved	

<1> Parameter o1-03, Digital Operator Display Selection, determines the units.

<2> The number of decimal places in the parameter value depends on the drive model and the ND/HD selection in parameter C6-01. This value has two decimal places (0.01 A) if the drive is set for a maximum applicable motor capacity up to and including 11 kW, and one decimal place (0.1 A) if the maximum applicable motor capacity is higher than 11 kW. *Refer to Power Ratings on page 463.*

<3> Communication error contents are saved until the fault is reset.

<4> Set the number of motor poles to parameter E2-04, E4-04, or E5-05 depending on the motor being used.

<5>

◆ Broadcast Messages

Data can be written from the master to all slave devices at the same time.

The slave address in a broadcast command message must be set to 00H. All slaves will receive the message, but will not respond.

Register No.	Contents	
0001H	Digital Input Command	
	bit 0	Forward Run (0: Stop 1: Run)
	bit 1	Direction Command (0: Forward, 1: Reverse)
	bit 2, 3	Reserved
	bit 4	External Fault
	bit 5	Fault Reset
	bit 6 to B	Reserved
	bit C	Multi-Function Digital Input S5
	bit D	Multi-Function Digital Input S6
	bit E	Multi-Function Digital Input S7
	bit F	Multi-Function Digital Input S8
0002H	Frequency Reference	30000/100%

◆ Fault Trace Contents

The table below shows the fault codes that can be read out by MEMOBUS/Modbus commands from the U2-□□ monitor parameters.

Table C.5 Fault Trace / History Register Contents

Fault Code	Fault Name	Fault Code	Fault Name
0002H	Undervoltage (Uv1)	0037H	Pullout Detection (Sto)
0003H	Control Power Supply Undervoltage (Uv2)	0038H	PG Hardware Fault (PGoH)
0004H	Soft Charge Circuit Fault (Uv3)	003BH	Too Many Speed Search Restarts (SEr)
0005H </>	IGBT Short Circuit (SC)	0041H	PID Feedback Loss (FbH)
0006H	Ground Fault (GF)	0042H	External Fault 1, Input Terminal S1 (EF1)
0007H	Overcurrent (oC)	0043H	External Fault 2, Input Terminal S2 (EF2)
0008H	Overvoltage (ov)	0044H	Mechanical Weakening Detection 1 (oL5)
0009H	Heatsink Overheat (oH)	0045H	Mechanical Weakening Detection 2 (UL5)
000AH	Heatsink Overheat (oH1)	0046H	Current Offset Fault (CoF)
000BH	Motor Overload (oL1)	0047H	PLC Detection Error 1 (PE1)
000CH	Drive Overload (oL2)	0048H	PLC Detection Error 2 (PE2)
000DH	Overtorque Detection 1 (oL3)	0049H	DriveWorksEZ Fault (dWFL)
000EH	Overtorque Detection 2 (oL4)	004DH	Output Voltage Detection Fault (voF)
000FH	Dynamic Braking Transistor (rr)	004EH	Braking Resistor Transistor Fault (rF)
0010H	Braking Resistor Overheat (rH)	004FH	Braking Transistor Overload Fault (boL)
0011H	External Fault at Input Terminal S3 (EF3)	0050H	Motor Overheat (NTC Input) (oH5)
0012H	External Fault at Input Terminal S4 (EF4)	0051H	LSo Fault
0013H	External Fault at Input Terminal S5 (EF5)	0052H	Node Setup Fault (nSE)
0014H	External Fault at Input Terminal S6 (EF6)	0053H	Thermistor Disconnect (THo)
0015H	External Fault at Input Terminal S7 (EF7)	005BH </>	Polarity Judge Timeout (dv7)
0016H	External Fault at Input Terminal S8 (EF8)	005FH	Power Unit Output Phase Loss 3 (LF3)
0018H	Overspeed (oS)	0060H	Current Unbalance (UnbC)
0019H	Excessive Speed Deviation (dEv)	0061H	Power Supply Module Undervoltage (Uv4)
001AH	PG Disconnect (PGo)	0083H	A/D Conversion Error (CPF02)
001BH	Input Phase Loss (PF)	0084H	PWM Data Fault (CPF03)
001CH	Output Phase Loss (LF)	0087H	EEPROM Memory Data Error (CPF06)
001DH	Motor Overheat (PTC input) (oH3)	0088H	Terminal Board Connection Error (CPF07)
001EH	Digital Operator Connection (oPr)	0089H	EEPROM Serial Communication Fault (CPF08)
001FH	EEPROM Write Error (Err)	008CH	RAM Fault (CPF11)
0020H	Motor Overheat (PTC input) (oH4)	008DH	Flash Memory Circuit Exception (CPF12)
0021H	MEMOBUS/Modbus Communication Error (CE)	008EH	Watchdog Circuit Exception (CPF13)
0022H	Option Communication Error (bUS)	008FH	Control Circuit Fault (CPF14)
0025H	Control Fault (CF)	0091H	Clock Fault (CPF16)
0026H	Zero-Servo Fault (SvE)	0092H	Timing Fault (CPF17)
0027H	Option External Fault (EF0)	0093H	Control Circuit Fault (CPF18)
0028H	PID Feedback Loss (FbL)	0094H	Control Circuit Fault (CPF19)
0029H	Undertorque Detection 1 (UL3)	0095H	Hardware Fault at Power Up (CPF20)
002AH	Undertorque Detection 2 (UL4)	0096H	Hardware Fault at Communication Start Up (CPF21)
002BH	High Slip Braking Overload (oL7)	0097H	A/D Conversion Fault (CPF22)
0030H	Hardware Fault (including oFx)	0098H	PWM Feedback Fault (CPF23)
0032H	Z Pulse Fall Detection (dv1)	0099H	Drive Unit Signal Fault (CPF24)
0033H	Z Pulse Noise Fault Detection (dv2)	009AH	Terminal Board is Not Properly Connected. (CPF25)
0034H	Inversion Detection (dv3)	009BH	ASIC BB Circuit Error (CPF26)
0035H	Inversion Prevention Detection (dv4)	009CH	ASIC PWM Setting Register Error (CPF27)
0036H	Output Current Imbalance (LF2)	009DH	ASIC PWM Pattern Error (CPF28)

Fault Code	Fault Name	Fault Code	Fault Name
009EH	ASIC On-delay Error (CPF29)	013BH	Control Response Selection 1 Error (oFA40)
009FH	ASIC BBON Error (CPF30)	013CH	Drive Timeout Waiting for Response (oFA41)
00A0H	ASIC Code Error (CPF31)	013DH	Control Response Selection 2 Error (oFA42)
00A1H	ASIC Start-up Error (CPF32)	013EH	Control Response Selection Error (oFA43)
00A2H	Watch-dog Error (CPF33)	0201H	Option Connection Error (oFb01)
00A3H	ASIC Power/Clock Error (CPF34)	0202H	Same Type of Option Card Already Connected (oFb02)
00A4H	External A/D Converter Error (CPF35)	0205H	A/D Conversion Error (oFb05)
00A9H	Control Circuit Error (CPF40)	0206H	Option Response Error (oFb06)
00AAH	Control Circuit Error (CPF41)	0210H	Option RAM Fault (oFb10)
00ABH	Control Circuit Error (CPF42)	0211H	Option Operation Mode Fault (SLMOD) (oFb11)
00ACH	Control Circuit Error (CPF43)	0212H	Drive Receive CRC Error (oFb12)
00ADH	Control Circuit Error (CPF44)	0213H	Drive Receive Frame Error (oFb13)
00AEH	Control Circuit Error (CPF45)	0214H	Drive Receive Abort Error (oFb14)
0101H	Option Compatibility Error (oFA00)	0215H	Option Receive CRC Error (oFb15)
0102H	Option Not Properly Connected (oFA01)	0216H	Option Receive Frame Error (oFb16)
0103H	Same Type of Option Card Already Connected (oFA02)	0217H	Option Receive Abort Error (oFb17)
0106H	A/D Conversion Error (oFA05)	0231H	Comm. ID Error (oFb30)
0107H	Option Response Error (oFA06)	0232H	Model Code Error (oFb31)
0111H	Option RAM Fault (oFA10)	0233H	Sumcheck Error (oFb32)
0112H	Option Operation Mode Fault (SLMOD) (oFA11)	0234H	Comm. option Timeout Waiting for Response (oFb33)
0113H	Drive Receive CRC Error (oFA12)	0235H	MEMOBUS Timeout (oFb34)
0114H	Drive Receive Frame Error (oFA13)	0236H	Drive Timeout Waiting for Response (oFb35)
0115H	Drive Receive Abort Error (oFA14)	0237H	CI Check Error (oFb36)
0116H	Option Receive CRC Error (oFA15)	0238H	Drive Timeout Waiting for Response (oFb37)
0117H	Option Receive Frame Error (oFA16)	0239H	Control Command Selection Error (oFb38)
0118H	Option Receive Abort Error (oFA17)	023AH	Drive Timeout Waiting for Response (oFb39)
0131H	Comm. ID Error (oFA30)	023BH	Control Response Selection 1 Error (oFb40)
0132H	Model Code Error (oFA31)	023CH	Drive Timeout Waiting for Response (oFb41)
0133H	Sumcheck Error (oFA32)	023DH	Control Response Selection 2 Error (oFb42)
0134H	Comm. Option Timeout Waiting for Response (oFA33)	023EH	Control Response Selection Error (oFb43)
0135H	MEMOBUS Timeout (oFA34)	0300H	Option Compatibility Error (oFC00)
0136H	Drive Timeout Waiting for Response (oFA35)	0301H	Option Not Properly Connected (oFC01)
0137H	CI Check Error (oFA36)	0302H	Same Type of Option Card Already Connected (oFC02)
0138H	Drive Timeout Waiting for Response (oFA37)	0305H	A/D Conversion Error (oFC05)
0139H	Control Command Selection Error (oFA38)	0306H	Option Response Error (oFC06)
013AH	Drive Timeout Waiting for Response (oFA39)		

<1> Available in drive software versions 1015 and later.

◆ Alarm Register Contents

The table below shows the alarm codes that can be read out from MEMOBUS/Modbus register 007FH.

Table C.6 Alarm Register 007FH Contents

Fault Code	Fault Name	Fault Code	Fault Name
0001H	Undervoltage (Uv)	0022H	Motor Overheat (oH3)
0002H	Overvoltage (ov)	0027H	PID Feedback Loss (FbL)
0003H	Heatsink Overheat (oH)	0028H	PID Feedback Loss (FbH)
0004H	Drive Overheat (oH2)	002AH	Drive Disabled (dnE)
0005H	Overtorque 1 (oL3)	002BH	PG Disconnected (PGo)
0006H	Overtorque 2 (oL4)	0031H	SI-T3 Watchdog Error (E5)
0007H	Run commands input error (EF)	0032H	SI-T3 Station Address Setting Error (AEr)
0008H	Drive Baseblock (bb)	0033H	SI-T3 Comm. Cycle Setting Error (CyC)
0009H	External Fault 3, input terminal S3 (EF3)	0034H	High Current Alarm (HCA)
000AH	External Fault 4, input terminal S4 (EF4)	0035H	Cooling Fan Maintenance Time (LT-1)
000BH	External Fault 5, input terminal S5 (EF5)	0036H	Capacitor Maintenance Time (LT-2)
000CH	External Fault 6, input terminal S6 (EF6)	0038H	SI-S EEPROM Error (EEP)
000DH	External Fault 7, input terminal S7 (EF7)	0039H	External Fault (input terminal S1) (EF1)
000EH	External Fault 8, input terminal S8 (EF8)	003AH	External Fault (input terminal S2) (EF2)
000FH	Cooling Fan Error (FAn)	003BH	Safe Disable Input (HbbF) <1>
0010H	Overspeed (oS)	003CH	Safe Disable Input (Hbb) <1>
0011H	Excessive Speed Deviation (dEv)	003DH	Mechanical Weakening Detection 1 (oL5)
0012H	PG Disconnected (PGo)	003EH	Mechanical Weakening Detection 2 (UL5)
0014H	MEMOBUS/Modbus Communication Error (CE)	003FH	PLC Alarm (PA1)
0015H	Option Communication Error (bUS)	0040H	PLC Alarm (PA2)
0016H	Serial Communication Transmission Error (CALL)	0041H	Output Voltage Detection Fault (voF)
0017H	Motor Overload (oL1)	0042H	IGBT Maintenance Time (90%) (TrPC)
0018H	Drive Overload (oL2)	0043H	Soft Charge Bypass Relay Maintenance Time (LT-3)
001AH	Option Card External Fault (EF0)	0044H	IGBT Maintenance Time (50%) (LT-4)
001BH	Motor Switch command input during run (rUn)	0045H	Braking Transistor Overload (boL)
001DH	Serial Communication Transmission Error (CALL)	0048H	Motor Overheat (NTC Input) (oH5)
001EH	Undertorque Detection 1 (UL3)	0049H	DriveWorksEZ Alarm (dWAL)
001FH	Undertorque Detection 2 (UL4)		
0020H	MEMOBUS/Modbus Test Mode Fault (SE)		

<1> Terminals H1, H2, DM+, and DM- on 600 V class models are designed to the functionality, but are not certified to EN61800-5-1, ISO13849 Cat. 3, IEC/EN61508 SIL2, Insulation coordination: class 1.

C.10 Enter Command

When writing parameters to the drive from the PLC using MEMOBUS/Modbus communication, parameter H5-11 determines whether an Enter command must be issued to enable these parameters. This section describes the types and functions of the Enter commands.

◆ Enter Command Types

The drive supports two types of Enter commands as shown in [Table C.7](#). An Enter command is enabled by writing 0 to register numbers 0900H or 0910H. It is only possible to write to these registers; attempting to read from these registers will cause an error.

Table C.7 Enter Command Types

Register No.	Description
0900H	Simultaneously writes data into the EEPROM (non-volatile memory) of the drive and enables the data in RAM. Parameter changes remain after cycling power.
0910H	Writes data in the RAM only. Parameter changes are lost when the drive is shut off.

Note: The EEPROM can only be written to 100,000 times, so it is recommended to limit the number of times writing to the EEPROM. The Enter command registers are write-only and if these registers are read, the register address will be invalid (Error code: 02H). An Enter command is not required when reference or broadcast data are sent to the drive.

◆ Enter Command Settings when Upgrading the Drive

When replacing previous Yaskawa drive models with the A1000 and keeping the MEMOBUS/Modbus communications settings, set parameter H5-11 in accordance with the Enter command configuration in the older drive. H5-11 determines whether an Enter command is necessary to activate parameter changes in the drive.

- If upgrading from a G7 or F7 series drive to an A1000, set parameter H5-11 to 0.
- If upgrading from a V7 series drive to an A1000, set parameter H5-11 to 1.

■ H5-11 and the Enter Command

An enter command is not required when writing registers 0000H to 001FH. Changes to those registers take effect immediately, independent of the setting in parameter H5-11.

H5-11 Settings	H5-11 = 0	H5-11 = 1
Drive being replaced	G7, F7	V7
How parameter settings are enabled	When the Enter command is received from the master.	As soon as the value is changed.
Upper/lower limit check	Upper/lower limit check is performed, taking the settings of related parameters into account.	Checks only the upper/lower limits of the parameters that were changed.
Default value of related parameters	Not affected. The settings of related parameters remain unchanged. They must be changed manually if needed.	Default settings of related parameters are changed automatically.
Error handling when setting multiple parameters	Data is accepted even if one setting is invalid. The invalid setting will be discarded. No error message occurs.	Error occurs if only one setting is invalid. All data that was sent are discarded.

C.11 Communication Errors

◆ MEMOBUS/Modbus Error Codes

A list of MEMOBUS/Modbus errors appears below.

When an error occurs, remove whatever caused the error and restart communications.

Error Code	Error Name
	Cause
01H	Function Code Error
	<ul style="list-style-type: none"> Attempted to set a function code from a PLC other than 03H, 08H, and 10H.
02H	Register Number Error
	<ul style="list-style-type: none"> A register number specified in the command message does not exist. Attempted to send a broadcast message using other register numbers than 0001H or 0002H.
03H	Bit Count Error
	<ul style="list-style-type: none"> Read data or write data is greater than 16 bits. Invalid command message quantity. In a write message, the “Number of Data Items” contained within the message does not equal twice the amount of data words (i.e., the total of Data 1+ Data 2, etc.).
21H	Data Setting Error
	<ul style="list-style-type: none"> Control data or parameter write data is outside the allowable setting range. Attempted to write a contradictory parameter setting.
22H	Write Mode Error
	<ul style="list-style-type: none"> During run, the user attempted to write a parameter that cannot be written to during run. During an EEPROM memory data error (CPF06), the master attempted to write to a parameter other than A1-00 to A1-05, E1-03, or o2-04. Attempted to write to read-only data.
23H	DC Bus Undervoltage Write Error
	<ul style="list-style-type: none"> During an undervoltage situation, the master attempted to write to parameters that cannot be written to during undervoltage.
24H	Write Error During Parameter Process
	<ul style="list-style-type: none"> Master attempted writing to the drive while the drive was processing parameter data.

◆ Slave Not Responding

In the following situations, the slave drive will ignore the command message sent from the master, and not send a response message:

- When a communications error (overrun, framing, parity, or CRC-16) is detected in the command message.
- When the slave address in the command message and the slave address in the drive do not match (remember to set the slave address for the drive using H5-01).
- When the gap between two blocks (8-bit) of a message exceeds 24 bits.
- When the command message data length is invalid.

Note: If the slave address specified in the command message is 00H, all slaves execute the write function, but do not return response messages to the master.

C.12 Self-Diagnostics

The drive has a built-in self-diagnosing function of the serial communication interface circuits. To perform the self-diagnosis function, use the following procedure.

DANGER! Electrical Shock Hazard. Do not connect or disconnect wiring while the power is on. Failure to comply will result in death or serious injury. Before servicing, disconnect all power to the equipment. The internal capacitor remains charged even after the power supply is turned off. The charge indicator LED will extinguish when the DC bus voltage is below 50 Vdc. To prevent electric shock, wait at least one minute after all indicators are OFF and measure the DC bus voltage level to confirm safe level.

1. Turn on the power to the drive.
2. Note the present terminal S6 function selection setting (H1-06) and set it for the communications test mode (H1-06 = 67).
3. Turn off the power to the drive.
4. With the power off, wire the drive as shown in [Figure C.8](#), connecting terminals R+ and S+, R- and S-, and S6 and SC.

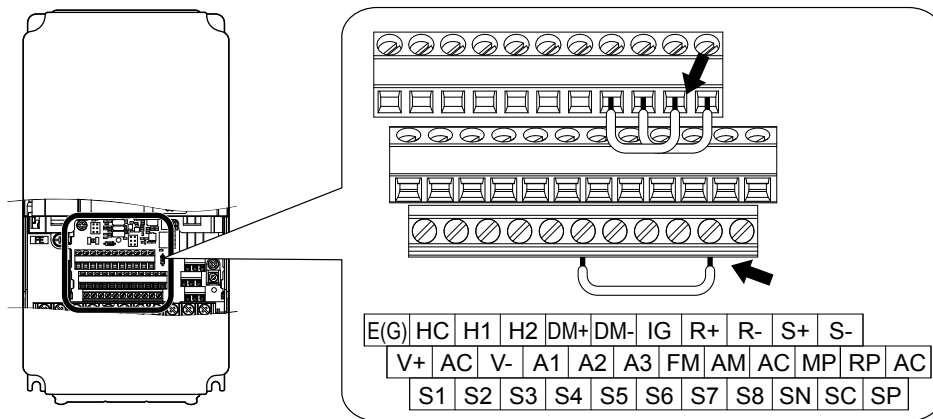

Figure C.8 Terminal Connections for Communication Self-Diagnostics

5. Set jumper S3 to source mode (internal power supply).
6. Turn the power to the drive back on.
7. During normal operation, the drive will display “Pass” to indicate that the communications test mode is operating normally.

When a fault occurs, the drive will display “CE” on the keypad display.

8. Turn off the power supply.
9. Remove the wire jumpers from terminal R+, R-, S+, S-, and S6-SC. Reset jumper S3 to its original position and set terminal S6 to its original function.
10. Return to normal operation.

This Page Intentionally Blank

Appendix: D

Standards Compliance

This appendix explains the guidelines and criteria for maintaining CE and UL standards.

D.1	SECTION SAFETY.....	646
D.2	EUROPEAN STANDARDS.....	648
D.3	UL AND CSA STANDARDS.....	656
D.4	SAFE DISABLE INPUT FUNCTION.....	675

D.1 Section Safety

WARNING

Electrical Shock Hazard

Do not connect or disconnect wiring while the power is on.

Failure to comply could result in death or serious injury.

Before servicing, disconnect all power to the equipment. The internal capacitor remains charged even after the power supply is turned off. The charge indicator LED will extinguish when the DC bus voltage is below 50 Vdc. To prevent electric shock, wait for at least the time specified on the warning label; After all indicators are OFF, measure the DC bus voltage level to confirm it has reached a safe level.

Do not operate equipment with covers removed.

Failure to comply could result in death or serious injury.

The diagrams in this section may show drives without covers or safety shields to show details. Be sure to reinstall covers or shields before operating the drives and run the drives according to the instructions described in this manual.

Always ground the motor-side grounding terminal.

Improper equipment grounding could result in death or serious injury by contacting the motor case.

Do not touch any terminals before the capacitors have fully discharged.

Failure to comply could result in death or serious injury.

Before wiring terminals, disconnect all power to the equipment. The internal capacitor remains charged even after the power supply is turned off. After shutting off the power, wait for at least the amount of time specified on the drive before touching any components.

Do not allow unqualified personnel to perform work on the drive.

Failure to comply could result in death or serious injury.

Installation, maintenance, inspection, and servicing must be performed only by authorized personnel familiar with installation, adjustment and maintenance of AC drives.

Do not perform work on the drive while wearing loose clothing, jewelry or without eye protection.

Failure to comply could result in death or serious injury.

Remove all metal objects such as watches and rings, secure loose clothing, and wear eye protection before beginning work on the drive.

Do not remove covers or touch circuit boards while the power is on.

Failure to comply could result in death or serious injury.

Fire Hazard

Tighten all terminal screws to the specified tightening torque.

Loose electrical connections could result in death or serious injury by fire due to overheating of electrical connections.

Do not use an improper voltage source.

Failure to comply could result in death or serious injury by fire.

Verify that the rated voltage of the drive matches the voltage of the incoming power supply before applying power.

Do not use improper combustible materials.

Failure to comply could result in death or serious injury by fire.

Attach the drive to metal or other noncombustible material.

NOTICE**Observe proper electrostatic discharge procedures (ESD) when handling the drive and circuit boards.**

Failure to comply may result in ESD damage to the drive circuitry.

Never connect or disconnect the motor from the drive while the drive is outputting voltage.

Improper equipment sequencing could result in damage to the drive.

Do not use unshielded wire for control wiring.

Failure to comply may cause electrical interference resulting in poor system performance. Use shielded twisted-pair wires and ground the shield to the ground terminal of the drive.

Do not allow unqualified personnel to use the product.

Failure to comply could result in damage to the drive or braking circuit.

Carefully review instruction manual TOBPC72060000 when connecting a braking option to the drive.

Do not modify the drive circuitry.

Failure to comply could result in damage to the drive and will void warranty.

Yaskawa is not responsible for modification of the product made by the user. This product must not be modified.

Check all the wiring to ensure that all connections are correct after installing the drive and connecting other devices.

Failure to comply could result in damage to the drive.

If a fuse is blown or a Ground Fault Circuit Interrupter (GFCI) is tripped, check the wiring and the selection of the peripheral devices.

Contact your supplier if the cause cannot be identified after checking the above.

Do not restart the drive immediately operate the peripheral devices if a fuse is blown or a GFCI is tripped.

Check the wiring and the selection of peripheral devices to identify the cause. Contact your supplier before restarting the drive or the peripheral devices if the cause cannot be identified.

D.2 European Standards



Figure D.1 CE Mark

The CE mark indicates compliance with European safety and environmental regulations. It is required for engaging in business and commerce in Europe.

European standards include the Machinery Directive for machine manufacturers, the Low Voltage Directive for electronics manufacturers, and the EMC guidelines for controlling noise.

This drive displays the CE mark based on the EMC guidelines and the Low Voltage Directive.

- **Low Voltage Directive:** 2006/95/EC
- **EMC Guidelines:** 2004/108/EC

Devices used in combination with this drive must also be CE certified and display the CE mark. When using drives displaying the CE mark in combination with other devices, it is ultimately the responsibility of the user to ensure compliance with CE standards. After setting up the device, verify that conditions meet European standards.

Note: 600 V class drives (models 5□□□□□□) are not compliant with European Standards.

◆ CE Low Voltage Directive Compliance

This drive has been tested according to European standard IEC61800-5-1, and it fully complies with the Low Voltage Directive. To comply with the Low Voltage Directive, be sure to meet the following conditions when combining this drive with other devices:

■ Area of Use

Do not use drives in areas with pollution higher than severity 2 and overvoltage category 3 in accordance with IEC664.

■ Factory Recommended Branch Circuit Protection

Yaskawa recommends installing one of the following types of branch circuit protection to maintain compliance with UL508C. Semiconductor protective type fuses are preferred. Alternate branch circuit protection devices are also listed in [Table D.1](#).

NOTICE: If a fuse is blown or a Ground Fault Circuit Interrupter (GFCI) is tripped, check the wiring and the selection of peripheral devices to identify the cause. Contact Yaskawa before restarting the drive or the peripheral devices if the cause cannot be identified.

Table D.1 Factory Recommended Drive Branch Circuit Protection

Drive Model	Fuse Type	
	Manufacturer: Bussmann	
	Model	Fuse Ampere Rating (A)
Three-Phase 200 V Class		
2A0004	FWH-70B	70
2A0006	FWH-70B	70
2A0008	FWH-70B	70
2A0010	FWH-70B	70
2A0012	FWH-70B	70
2A0018	FWH-90B	90
2A0021	FWH-90B	90
2A0030	FWH-100B	100
2A0040	FWH-200B	200
2A0056	FWH-200B	200
2A0069	FWH-200B	200
2A0081	FWH-300A	300
2A0110	FWH-300A	300
2A0138	FWH-350A	350

Drive Model	Fuse Type	
	Manufacturer: Bussmann	
	Model	Fuse Ampere Rating (A)
2A0169	FWH-400A	400
2A0211	FWH-400A	400
2A0250	FWH-600A	600
2A0312	FWH-700A	700
2A0360	FWH-800A	800
2A0415	FWH-1000A	1000
Three-Phase 400 V Class		
4A0002	FWH-40B	40
4A0004	FWH-50B	50
4A0005	FWH-70B	70
4A0007	FWH-70B	70
4A0009	FWH-90B	90
4A0011	FWH-90B	90
4A0018	FWH-80B	80
4A0023	FWH-100B	100
4A0031	FWH-125B	125
4A0038	FWH-200B	200
4A0044	FWH-250A	250
4A0058	FWH-250A	250
4A0072	FWH-250A	250
4A0088	FWH-250A	250
4A0103	FWH-250A	250
4A0139	FWH-350A	350
4A0165	FWH-400A	400
4A0208	FWH-500A	500
4A0250	FWH-600A	600
4A0296	FWH-700A	700
4A0362	FWH-800A	800
4A0414	FWH-800A	800
4A0515	FWH-1000A	1000
4A0675	FWH-1200A	1200
4A0930	FWH-1200A	1200
4A1200	FWH-1600A	1600
Three-Phase 600 V Class		
5A0003 </>	FWP-50B	50
5A0004 </>	FWP-50B	50
5A0006 </>	FWP-60B	60
5A0009 </>	FWP-60B	60
5A0011 </>	FWP-70B	70
5A0017 </>	FWP-100B	100
5A0022 </>	FWP-100B	100
5A0027 </>	FWP-125A	125
5A0032 </>	FWP-125A	125
5A0041 </>	FWP-175A	175
5A0052 </>	FWP-175A	175
5A0062 </>	FWP-250A	250

D.2 European Standards

Drive Model	Fuse Type	
	Manufacturer: Bussmann	
	Model	Fuse Ampere Rating (A)
5A0077 </>	FWP-250A	250
5A0099 </>	FWP-250A	250
5A0125 </>	FWP-350A	350
5A0145 </>	FWP-350A	350
5A0192 </>	FWP-600A	600
5A0242 </>	FWP-600A	600

<1> 600 V class drives are not compliant with European Standards.

■ Guarding Against Harmful Materials

When installing IP00/Open Type enclosure drives, use an enclosure that prevents foreign material from entering the drive from above or below.

■ Grounding

The drive is designed to be used in T-N (grounded neutral point) networks. If installing the drive in other types of grounded systems, contact your Yaskawa representative for instructions.

◆ EMC Guidelines Compliance

This drive is tested according to European standards EN61800-3: 2004.

■ EMC Filter Installation

The following conditions must be met to ensure continued compliance with guidelines. *Refer to EMC Filters on page 653* for EMC filter selection.

Installation Method

Verify the following installation conditions to ensure that other devices and machinery used in combination with this drive also comply with EMC guidelines.

1. Install an EMC noise filter to the input side specified by Yaskawa for compliance with European standards.
2. Place the drive and EMC noise filter in the same enclosure.
3. Use braided shield cable for the drive and motor wiring, or run the wiring through a metal conduit.
4. Keep wiring as short as possible. Ground the shield on both the drive side and the motor side.

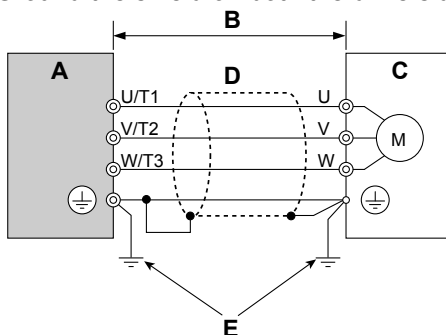

A – Drive

B – 10 m max cable length between drive and motor

C – Motor

D – Metal conduit

E – Ground wire should be as short as possible.

Figure D.2 Installation Method

5. Make sure the protective earthing conductor complies with technical standards and local safety regulations.

WARNING! Electrical Shock Hazard. Because the leakage current exceeds 3.5 mA in models 4A0414 to 4A1200, IEC 61800-5-1 states that either the power supply must be automatically disconnected in case of discontinuity of the protective earthing conductor, or a protective earthing conductor with a cross-section of at least 10 mm² (Cu) or 16 mm² (Al) must be used. Failure to comply may result in death or serious injury.

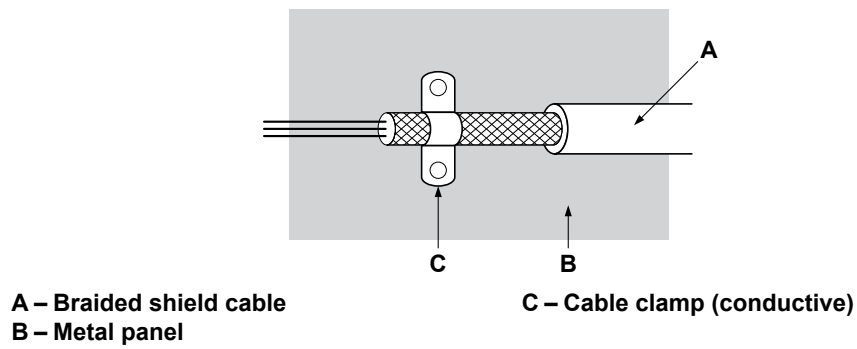
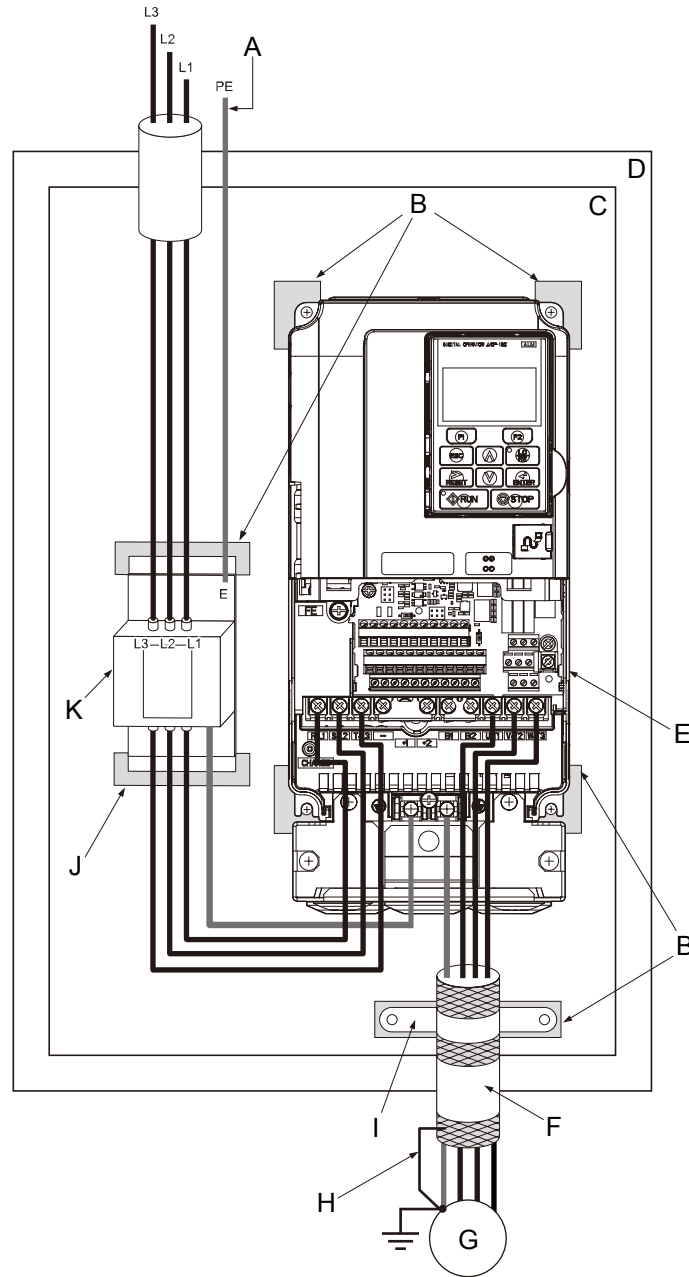

Figure D.3 Ground Area

6. Connect a DC link choke to minimize harmonic distortion. [Refer to DC Link Chokes for EN 61000-3-2 Compliance on page 655.](#)

Three-Phase 200 V / 400 V Class



- | | |
|--|--|
| A – Make sure the ground wire is grounded | G – Motor |
| B – Grounding surface (remove any paint or sealant) | H – Cable shield ground |
| C – Metal plate | I – Cable clamp |
| D – Enclosure panel | J – Ground plate (scrape off any visible paint) |
| E – Drive | K – EMC noise filter |
| F – Motor cable (braided shield cable, max. 10 m) | |

Figure D.4 EMC Filter and Drive Installation for CE Compliance (Three-Phase 200 V / 400 V Class)

■ EMC Filters

Install the drive with the EMC filters listed in [Table D.2](#) to comply with the EN61800-3 requirements.

Table D.2 EN61800-3 Filters

Drive Model	Filter Data (Manufacturer: Schaffner)					Figure
	Type	Rated Current (A)	Weight (lb)	Dimensions [W x D x H] (in)	Y x X (in)	
Three-Phase 200 V Class						
2A0004	FS5972-10-07	10	2.6	5.6 × 1.8 × 13.0	4.5 × 12.3	1
2A0006						
2A0008						
2A0010	FS5972-18-07	18	2.9	5.6 × 1.8 × 13.0	4.5 × 12.3	
2A0012						
2A0018						
2A0021	FS5972-35-07	35	4.6	8.1 × 2.0 × 14.0	6.9 × 13.2	
2A0030						
2A0040						
2A0056	FS5972-60-07	60	8.8	9.3 × 2.6 × 16.1	8.1 × 15.4	
2A0069	FS5972-100-35	100	7.5	3.5 × 5.9 × 13.0	2.6 × 10.0	2
2A0081						
2A0110						
2A0138	FS5972-170-40	170	13.2	4.7 × 6.7 × 17.8	4.0 × 14.4	
2A0169						
2A0211						
2A0250	FS5972-250-37	250	25.8	5.1 × 9.5 × 24.0	3.5 × 19.6	
2A0312						
2A0360						
2A0415	FS5972-410-99	410	23.1	10.2 × 4.5 × 15.2	9.3 × 4.7	3
2A0312	FS5972-600-99	600	24.3	10.2 × 5.3 × 15.2	9.3 × 4.7	
2A0415						
Three-Phase 400 V Class						
4A0002	FS5972-10-07	10	2.7	5.6 × 1.8 × 13.0	4.5 × 12.3	1
4A0004						
4A0005						
4A0007						
4A0009	FS5972-18-07	18	2.9	5.6 × 1.8 × 13.0	4.5 × 12.3	
4A0011						
4A0018	FS5972-35-07	35	4.6	8.1 × 2.0 × 14.0	6.9 × 13.2	
4A0023						
4A0031						
4A0038	FS5972-60-07	60	8.8	9.3 × 2.6 × 16.1	8.0 × 15.4	
4A0044						
4A0058						
4A0072	FS5972-100-35	100	16.5	3.5 × 5.9 × 13.0	2.6 × 10.0	2
4A0088						
4A0103						
4A0139	FS5972-170-35	170	10.4	4.7 × 6.7 × 17.8	4.0 × 14.4	
4A0165						
4A0208	FS5972-250-37	250	25.8	5.1 × 9.5 × 24.0	3.5 × 19.6	

D.2 European Standards

Drive Model	Filter Data (Manufacturer: Schaffner)					Figure
	Type	Rated Current (A)	Weight (lb)	Dimensions [W x D x H] (in)	Y x X (in)	
4A0250	FS5972-410-99	410	23.1	10.2 × 4.5 × 15.2	9.3 × 4.7	3
4A0296						
4A0362						
4A0414	FS5972-600-99	600	24.3	10.2 × 5.3 × 15.2	9.3 × 4.7	
4A0515						
4A0675	FS5972-800-99	800	69.4	11.8 × 6.3 × 28.2	10.8 × 8.3	
4A0930	FS5972-600-99 <1>	600	24.3	10.2 × 5.3 × 15.2	9.3 × 4.7	
4A1200	FS5972-800-99 <1>	800	69.4	11.8 × 28.2 × 6.3	10.8 × 8.3	

<1> Connect two of the same filters in parallel.

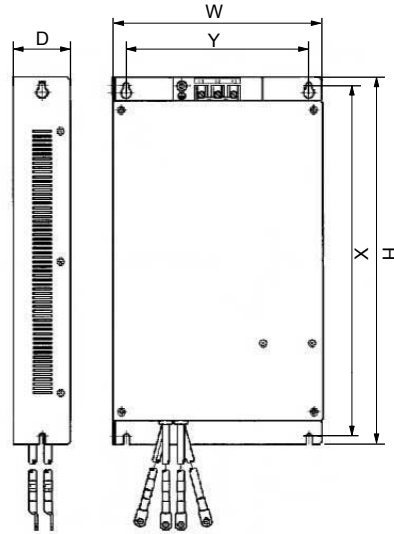

Figure 1

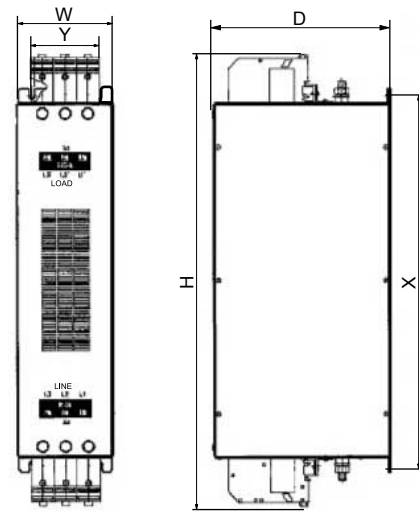

Figure 2

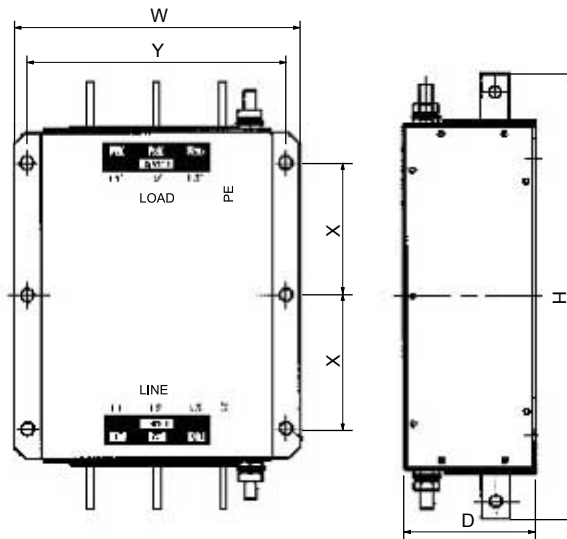

Figure 3

Figure D.5 EMC Filter Dimensions

■ DC Link Chokes for EN 61000-3-2 Compliance

Table D.3 DC Link Chokes for Harmonic Reduction

Drive Model	DC Link Chokes	
	Model	Rating
200 V Three-Phase Units		
2A0004	UZDA-B	5.4 A 8 mH
2A0006		
400 V Three-Phase Units		
4A0002	UZDA-B	3.2 A 28 mH
4A0004		

Note: DC link chokes are not required for other models to comply with EMC.

D.3 UL and CSA Standards

◆ UL Standards Compliance

The UL/cUL mark applies to products in the United States and Canada. It indicates that UL has performed product testing and evaluation, and determined that their stringent standards for product safety have been met. For a product to receive UL certification, all components inside that product must also receive UL certification.



Figure D.6 UL/cUL Mark

This drive is tested in accordance with UL standard UL508C and complies with UL requirements. The conditions described below must be met to maintain compliance when using this drive in combination with other equipment:

■ Installation Area

Do not install the drive to an area greater than pollution degree 2 (UL standard).

■ Ambient Temperature

-10 to +40 °C (IP20/NEMA Type 1 Enclosure)

-10 to +50 °C (IP00 Open Type Enclosure)

■ Main Circuit Terminal Wiring

Yaskawa recommends using closed-loop crimp terminals on all drive models. To maintain UL/cUL approval, UL-Listed closed-loop crimp terminals are specifically required when wiring the drive main circuit terminals on models 2A0110 to 2A0415, 4A0058 to 4A1200, and 5A0041 to 5A0242. Use only the tools recommended by the terminal manufacturer for crimping. [Refer to Closed-Loop Crimp Terminal Size on page 663](#) for closed-loop crimp terminal recommendations.

The wire gauges listed in the following tables are Yaskawa recommendations. Refer to local codes for proper wire gauge selections.

Note: The ⊕ mark indicates the terminals for protective ground connection as defined in IEC60417-5019.
 Grounding impedance:
 200 V: 100 Ω or less
 400 V: 10 Ω or less
 600 V: 10 Ω or less

Wire Gauges and Tightening Torques

Table D.4 Wire Gauge and Torque Specifications (Three-Phase 200 V Class)

Drive Model	Terminal	Recomm. Gauge AWG, kcmil	Wire Range AWG, kcmil	Screw Size	Tightening Torque N·m (lb.in.)
2A0004 2A0006 2A0008 2A0010	R/L1, S/L2, T/L3	14	14 to 10	M4	1.2 to 1.5 (10.6 to 13.3)
	U/T1, V/T2, W/T3	14	14 to 10		
	-, +1, +2	-	14 to 10		
	B1, B2	-	14 to 10		
	⊕	10 <I>	14 to 10		
2A0012	R/L1, S/L2, T/L3	12	14 to 10	M4	1.2 to 1.5 (10.6 to 13.3)
	U/T1, V/T2, W/T3	14	14 to 10		
	-, +1, +2	-	14 to 10		
	B1, B2	-	14 to 10		
	⊕	10 <I>	14 to 10		

Drive Model	Terminal	Recomm. Gauge AWG, kcmil	Wire Range AWG, kcmil	Screw Size	Tightening Torque N·m (lb.in.)
2A0018	R/L1, S/L2, T/L3	10	12 to 10	M4	1.2 to 1.5 (10.6 to 13.3)
	U/T1, V/T2, W/T3	10	14 to 10		
	-, +1, +2	-	14 to 10		
	B1, B2	-	14 to 10		
	⊕	10 $\langle \! / \! \rangle$	14 to 10		
2A0021	R/L1, S/L2, T/L3	10	12 to 10	M4	1.2 to 1.5 (10.6 to 13.3)
	U/T1, V/T2, W/T3	10	12 to 10		
	-, +1, +2	-	12 to 10		
	B1, B2	-	14 to 10		
	⊕	10 $\langle \! / \! \rangle$	12 to 10		
2A0030	R/L1, S/L2, T/L3	8	10 to 6	M4	2.1 to 2.3 (18.4 to 20.4)
	U/T1, V/T2, W/T3	8	10 to 6		
	-, +1, +2	-	10 to 6		
	B1, B2	-	14 to 10		
	⊕	8 $\langle \! / \! \rangle$	10 to 8	M5	2 to 2.5 (17.7 to 22.1)
2A0040	R/L1, S/L2, T/L3	6	8 to 6	M4	2.1 to 2.3 (18.4 to 20.4)
	U/T1, V/T2, W/T3	8	8 to 6		
	-, +1, +2	-	6		
	B1, B2	-	12 to 10		
	⊕	8 $\langle \! / \! \rangle$	10 to 8	M5	2 to 2.5 (17.7 to 22.1)
2A0056	R/L1, S/L2, T/L3	4	6 to 4	M6	5.4 to 6.0 (47.8 to 53.1)
	U/T1, V/T2, W/T3	4	6 to 4		
	-, +1, +2	-	6 to 4		
	B1, B2	-	10 to 6	M5	2.7 to 3.0 (23.9 to 26.6)
	⊕	6	8 to 6	M6	4 to 6 (35.4 to 53.1)
2A0069	R/L1, S/L2, T/L3	3	4 to 3	M8	9.9 to 11.0 (87.6 to 97.4)
	U/T1, V/T2, W/T3	3	4 to 3		
	-, +1, +2	-	4 to 3		
	B1, B2	-	8 to 6	M5	2.7 to 3.0 (23.9 to 26.6)
	⊕	6	6 to 4	M6	4 to 6 (35.4 to 53.1)
2A0081	R/L1, S/L2, T/L3	2	3 to 2	M8	9.9 to 11.0 (87.6 to 97.4)
	U/T1, V/T2, W/T3	2	3 to 2		
	-, +1, +2	-	3 to 2		
	B1, B2	-	6	M5	2.7 to 3.0 (23.9 to 26.6)
	⊕	6	6 to 4	M6	4 to 6 (35.4 to 53.1)
2A0110 $\langle \! / \! \rangle$	R/L1, S/L2, T/L3	1/0	3 to 1/0	M8	9 to 11 (79.7 to 97.4)
	U/T1, V/T2, W/T3	1/0	3 to 1/0		
	-, +1	-	2 to 1/0		
	B1, B2	-	6 to 1/0		
	⊕	6	6 to 4		
2A0138 $\langle \! / \! \rangle$	R/L1, S/L2, T/L3	2/0	1 to 2/0	M10	18 to 23 (159 to 204)
	U/T1, V/T2, W/T3	2/0	1 to 2/0		
	-, +1	-	1/0 to 3/0		
	B1, B2	-	4 to 2/0		
	⊕	4	4	M8	9 to 11 (79.7 to 97.4)

D.3 UL and CSA Standards

Drive Model	Terminal	Recomm. Gauge AWG, kcmil	Wire Range AWG, kcmil	Screw Size	Tightening Torque N-m (lb.in.)
2A0169 <2>	R/L1, S/L2, T/L3	4/0	2/0 to 4/0	M10	18 to 23 (159 to 204)
	U/T1, V/T2, W/T3	4/0	3/0 to 4/0		
	-, +1	-	1 to 4/0		
	+3	-	1/0 to 4/0		
	⊕	4	4 to 2		
2A0211 <2>	R/L1, S/L2, T/L3	1/0 × 2P	1/0 to 2/0	M10	18 to 23 (159 to 204)
	U/T1, V/T2, W/T3	1/0 × 2P	1/0 to 2/0		
	-, +1	-	1 to 4/0		
	+3	-	1/0 to 4/0		
	⊕	4	4 to 1/0		
2A0250 <2>	R/L1, S/L2, T/L3	3/0 × 2P	3/0 to 300	M12	32 to 40 (283 to 354)
	U/T1, V/T2, W/T3	3/0 × 2P	3/0 to 300		
	-, +1	-	3/0 to 300		
	+3	-	2 to 300	M10	18 to 23 (159 to 204)
	⊕	3	3 to 300	M12	32 to 40 (283 to 354)
2A0312 <2>	R/L1, S/L2, T/L3	4/0 × 2P	3/0 to 300	M12	32 to 40 (283 to 354)
	U/T1, V/T2, W/T3	3/0 × 2P	3/0 to 300		
	-, +1	-	3/0 to 300		
	+3	-	3/0 to 300	M10	18 to 23 (159 to 204)
	⊕	2	2 to 300	M12	32 to 40 (283 to 354)
2A0360 <2>	R/L1, S/L2, T/L3	250 × 2P	4/0 to 600	M12	32 to 40 (283 to 354)
	U/T1, V/T2, W/T3	4/0 × 2P	4/0 to 600		
	-, +1	-	250 to 600		
	+3	-	3/0 to 600	M10	18 to 23 (159 to 204)
	⊕	1	1 to 350	M12	32 to 40 (283 to 354)
2A0415 <2>	R/L1, S/L2, T/L3	350 × 2P	250 to 600	M12	32 to 40 (283 to 354)
	U/T1, V/T2, W/T3	300 × 2P	300 to 600		
	-, +1	-	300 to 600		
	+3	-	3/0 to 600	M10	18 to 23 (159 to 204)
	⊕	1	1 to 350	M12	32 to 40 (283 to 354)

<1> When installing an EMC filter, additional measures must be taken to comply with IEC61800-5-1. [Refer to EMC Filter Installation on page 650](#) for details.

<2> Drive models 2A0110 to 2A0415 require the use of UL-Listed closed-loop crimp terminals for UL/cUL compliance. Use only the tools recommended by the terminal manufacturer for crimping.

Table D.5 Wire Gauge and Torque Specifications (Three-Phase 400 V Class)

Drive Model	Terminal	Recomm. Gauge AWG, kcmil	Wire Range AWG, kcmil	Screw Size	Tightening Torque N·m (lb.in.)
4A0002 4A0004	R/L1, S/L2, T/L3	14	14 to 10	M4	1.2 to 1.5 (10.6 to 13.3)
	U/T1, V/T2, W/T3	14	14 to 10		
	-, +1, +2	-	14 to 10		
	B1, B2	-	14 to 10		
	⊕	12	14 to 12		
4A0005 4A0007 4A0009	R/L1, S/L2, T/L3	14	14 to 10	M4	1.2 to 1.5 (10.6 to 13.3)
	U/T1, V/T2, W/T3	14	14 to 10		
	-, +1, +2	-	14 to 10		
	B1, B2	-	14 to 10		
	⊕	10	14 to 10		
4A0011	R/L1, S/L2, T/L3	12	14 to 10	M4	1.2 to 1.5 (10.6 to 13.3)
	U/T1, V/T2, W/T3	14	14 to 10		
	-, +1, +2	-	14 to 10		
	B1, B2	-	14 to 10		
	⊕	10	14 to 10		
4A0018	R/L1, S/L2, T/L3	10	12 to 6	M4	2.1 to 2.3 (18.4 to 20.4)
	U/T1, V/T2, W/T3	10	12 to 6		
	-, +1, +2	-	12 to 6		
	B1, B2	-	12 to 10		
	⊕	10	14 to 10	M5	2 to 2.5 (17.7 to 22.1)
4A0023	R/L1, S/L2, T/L3	10	10 to 6	M4	2.1 to 2.3 (18.4 to 20.4)
	U/T1, V/T2, W/T3	10	10 to 6		
	-, +1, +2	-	12 to 6		
	B1, B2	-	12 to 10		
	⊕	10	12 to 10	M5	2 to 2.5 (17.7 to 22.1)
4A0031	R/L1, S/L2, T/L3	8	8 to 6	M5	2.7 to 3.0 (23.9 to 26.6)
	U/T1, V/T2, W/T3	8	10 to 6		
	-, +1, +2	-	10 to 6		
	B1, B2	-	10 to 8	M5	4 to 6 (35.4 to 53.1)
	⊕	8	10 to 8	M6	
4A0038	R/L1, S/L2, T/L3	6	8 to 6	M5	2.7 to 3.0 (23.9 to 26.6)
	U/T1, V/T2, W/T3	8	8 to 6		
	-, +1, +2	-	6		
	B1, B2	-	10 to 8	M5	4 to 6 (35.4 to 53.1)
	⊕	6	10 to 6	M6	
4A0044	R/L1, S/L2, T/L3	6	6 to 4	M6	5.4 to 6.0 (47.8 to 53.1)
	U/T1, V/T2, W/T3	6	6 to 4		
	-, +1, +2	-	6 to 4		
	B1, B2	-	10 to 8	M5	2.7 to 3.0 (23.9 to 26.6)
	⊕	6	8 to 6	M6	4 to 6 (35.4 to 53.1)
4A0058 <I>	R/L1, S/L2, T/L3	4	6 to 4	M8	9 to 11 (79.7 to 97.4)
	U/T1, V/T2, W/T3	4	6 to 4		
	-, +1	-	6 to 1		
	B1, B2	-	8 to 4		
	⊕	6	8 to 6		

D.3 UL and CSA Standards

Drive Model	Terminal	Recomm. Gauge AWG, kcmil	Wire Range AWG, kcmil	Screw Size	Tightening Torque N·m (lb.in.)
4A0072 < >	R/L1, S/L2, T/L3	3	4 to 3	M8	9 to 11 (79.7 to 97.4)
	U/T1, V/T2, W/T3	3	4 to 3		
	-, +1	-	4 to 1		
	B1, B2	-	6 to 3		
	⊕	6	6		
4A0088 < >	R/L1, S/L2, T/L3	2	3 to 1/0	M8	9 to 11 (79.7 to 97.4)
	U/T1, V/T2, W/T3	2	3 to 1/0		
	-, +1	-	3 to 1/0		
	+3	-	6 to 1/0		
	⊕	4	6 to 4		
4A0103 < >	R/L1, S/L2, T/L3	1/0	2 to 1/0	M8	9 to 11 (79.7 to 97.4)
	U/T1, V/T2, W/T3	1	2 to 1/0		
	-, +1	-	3 to 1/0		
	+3	-	4 to 1/0		
	⊕	4	6 to 4		
4A0139 < >	R/L1, S/L2, T/L3	3/0	1/0 to 4/0	M10	18 to 23 (159 to 204)
	U/T1, V/T2, W/T3	2/0	1/0 to 4/0		
	-, +1	-	1/0 to 4/0		
	+3	-	3 to 4/0		
	⊕	4	4		
4A0165 < >	R/L1, S/L2, T/L3	4/0	3/0 to 4/0	M10	18 to 23 (159 to 204)
	U/T1, V/T2, W/T3	4/0	3/0 to 4/0		
	-, +1	-	1 to 4/0		
	+3	-	1/0 to 4/0		
	⊕	4	4 to 2		
4A0208 < >	R/L1, S/L2, T/L3	300	2 to 300	M10	18 to 23 (159 to 204)
	U/T1, V/T2, W/T3	300	2 to 300		
	-, +1	-	1 to 250		
	+3	-	3 to 3/0		
	⊕	4	4 to 300		
4A0250 < >	R/L1, S/L2, T/L3	400	1 to 600	M10	18 to 23 (159 to 204)
	U/T1, V/T2, W/T3	400	1/0 to 600		
	-, +1	-	3/0 to 600		
	+3	-	1 to 325		
	⊕	2	2 to 350		
4A0296 < >	R/L1, S/L2, T/L3	500	2/0 to 600	M12	32 to 40 (283 to 354)
	U/T1, V/T2, W/T3	500	2/0 to 600		
	-, +1	-	3/0 to 600	M10	18 to 23 (159 to 204)
	+3	-	1 to 325		
	⊕	2	2 to 350		
4A0362 < >	R/L1, S/L2, T/L3	4/0 × 2P	3/0 to 600	M12	32 to 40 (283 to 354)
	U/T1, V/T2, W/T3	4/0 × 2P	3/0 to 600		
	-, +1	-	4/0 to 600	M10	18 to 23 (159 to 204)
	+3	-	3/0 to 600		
	⊕	1	1 to 350		

Drive Model	Terminal	Recomm. Gauge AWG, kcmil	Wire Range AWG, kcmil	Screw Size	Tightening Torque N·m (lb.in.)
4A0414 <1> <2>	R/L1, S/L2, T/L3	300 × 2P	4/0 to 300	M12	32 to 40 (283 to 354)
	U/T1, V/T2, W/T3	300 × 2P	4/0 to 300		
	-,+1	–	3/0 to 300		
	+3	–	3/0 to 300		
	⊕	1	1 to 3/0		
4A0515 <1> <2>	R/L1, S/L2, T/L3	3/0 × 4P	3/0 to 300	M12	32 to 40 (283 to 354)
	U/T1, V/T2, W/T3	4/0 × 4P	3/0 to 300		
	-,+1	–	1/0 to 300		
	+3	–	1/0 to 300		
	⊕	1/0	1/0 to 300		
4A0675 <1> <2>	R/L1, S/L2, T/L3	300 × 4P	4/0 to 300	M12	32 to 40 (283 to 354)
	U/T1, V/T2, W/T3	300 × 4P	4/0 to 300		
	-,+1	–	1/0 to 300		
	+3	–	1/0 to 300		
	⊕	2/0	2/0 to 300		
4A0930 <1> <2>	R/L1, S/L2, T/L3, R1/L11, S1/L21, T1/L31	4/0 × 4P×2	3/0 to 300	M12	32 to 40 (283 to 354)
	U/T1, V/T2, W/T3	4/0 × 4P×2	3/0 to 300		
	-,+1	–	4/0 to 300		
	+3	–	4/0 to 300		
	⊕	3/0	3/0 to 250		
4A1200 <1> <2>	R/L1, S/L2, T/L3, R1/L11, S1/L21, T1/L31	300 × 4P×2	4/0 to 300	M12	32 to 40 (283 to 354)
	U/T1, V/T2, W/T3	300 × 4P×2	4/0 to 300		
	-,+1	–	250 to 300		
	+3	–	4/0 to 300		
	⊕	4/0	4/0 to 250		

<1> Drive models 4A0058 to 4A1200 require the use of UL-Listed closed-loop crimp terminals for UL/cUL compliance. Use only the tools recommended by the terminal manufacturer for crimping.

<2> When installing an EMC filter, additional measures must be taken to comply with IEC61800-5-1. *Refer to EMC Filter Installation on page 650* for details.

D.3 UL and CSA Standards

Table D.6 Wire Gauge and Torque Specifications (Three-Phase 600 V Class)

Drive Model	Terminal	Recomm. Gauge AWG, kcmil	Wire Range AWG, kcmil	Screw Size	Tightening Torque N·m (lb.in.)
5A0003 5A0004 5A0006	R/L1, S/L2, T/L3	14	14 to 10	M4	1.2 to 1.5 (10.6 to 13.3)
	U/T1, V/T2, W/T3	14	14 to 10		
	-, +1, +2	-	14 to 10		
	B1, B2	-	14 to 10		
	⊕	10	14 to 10		
5A0009	R/L1, S/L2, T/L3	14	14 to 10	M4	1.2 to 1.5 (10.6 to 13.3)
	U/T1, V/T2, W/T3	14	14 to 10		
	-, +1, +2	-	14 to 10		
	B1, B2	-	14 to 10		
	⊕	10	12 to 10		
5A0011	R/L1, S/L2, T/L3	10	14 to 6	M4	1.2 to 1.5 (10.6 to 13.3)
	U/T1, V/T2, W/T3	14	14 to 6		
	-, +1, +2	-	14 to 6		
	B1, B2	-	14 to 10		
	⊕	8	12 to 8	M5	2 to 2.5 (17.7 to 22.1)
5A0017	R/L1, S/L2, T/L3	10	10 to 6	M5	2 to 2.5 (17.7 to 22.1)
	U/T1, V/T2, W/T3	10	10 to 6		
	-, +1, +2	-	10 to 6		
	B1, B2	-	10 to 8		
	⊕	8	12 to 8	M6	4 to 6 (35.4 to 53.1)
5A0022	R/L1, S/L2, T/L3	8	10 to 6	M5	2 to 2.5 (17.7 to 22.1)
	U/T1, V/T2, W/T3	10	10 to 6		
	-, +1, +2	-	10 to 6		
	B1, B2	-	10 to 8		
	⊕	8	10 to 6	M6	4 to 6 (35.4 to 53.1)
5A0027 5A0032	R/L1, S/L2, T/L3	6	6 to 4	M6	4 to 6 (35.4 to 53.1)
	U/T1, V/T2, W/T3	6	6 to 4		
	-, +1, +2	-	6 to 4		
	B1, B2	-	10 to 8	M5	2 to 2.5 (17.7 to 22.1)
	⊕	6	10 to 6	M6	4 to 6 (35.4 to 53.1)
5A0041	R/L1, S/L2, T/L3	6	10 to 3	M8	9 to 11 (79.7 to 97.4)
	U/T1, V/T2, W/T3	6	10 to 3		
	-, +1	-	6 to 1		
	B1, B2	-	12 to 3		
	⊕	6	6		
5A0052	R/L1, S/L2, T/L3	4	10 to 3	M8	9 to 11 (79.7 to 97.4)
	U/T1, V/T2, W/T3	6	10 to 3		
	-, +1	-	6 to 1		
	B1, B2	-	8 to 3		
	⊕	6	6		
5A0062	R/L1, S/L2, T/L3	4	10 to 4/0	M10	18 to 23 (159 to 204)
	U/T1, V/T2, W/T3	4	10 to 4/0		
	-, +1	-	4 to 4/0		
	+3	-	6 to 4/0		
	⊕	4	4		

Drive Model	Terminal	Recomm. Gauge AWG, kcmil	Wire Range AWG, kcmil	Screw Size	Tightening Torque N·m (lb.in.)
5A0077	R/L1, S/L2, T/L3	3	10 to 4/0	M10	18 to 23 (159 to 204)
	U/T1, V/T2, W/T3	3	10 to 4/0		
	-, +1	-	3 to 4/0		
	+3	-	6 to 4/0		
	⊕	4	4		
5A0099	R/L1, S/L2, T/L3	1/0	10 to 4/0	M10	18 to 23 (159 to 204)
	U/T1, V/T2, W/T3	1	10 to 4/0		
	-, +1	-	2 to 4/0		
	+3	-	4 to 4/0		
	⊕	4	4		
5A0125	R/L1, S/L2, T/L3	2/0	1 to 300	M10	18 to 23 (159 to 204)
	U/T1, V/T2, W/T3	2/0	1 to 300		
	-, +1	-	2/0 to 3/0		
	+3	-	1 to 1/0		
	⊕	3	4 to 300		
5A0145	R/L1, S/L2, T/L3	3/0	2/0 to 300	M10	18 to 23 (159 to 204)
	U/T1, V/T2, W/T3	3/0	2/0 to 300		
	-, +1	-	3/0 to 4/0		
	+3	-	1/0 to 2/0		
	⊕	3	4 to 300		
5A0192	R/L1, S/L2, T/L3	300	2/0 to 600	M12	32 to 40 (283 to 354)
	U/T1, V/T2, W/T3	250	2/0 to 600		
	-, +1	-	2/0 to 400	M10	18 to 23 (159 to 204)
	+3	-	2/0 to 250		
	⊕	1	1 to 350		
5A0242	R/L1, S/L2, T/L3	400	2/0 to 600	M12	32 to 40 (283 to 354)
	U/T1, V/T2, W/T3	350	2/0 to 600		
	-, +1	-	2/0 to 500		
	+3	-	250 to 300	M10	18 to 23 (159 to 204)
	⊕	1	1 to 350	M12	32 to 40 (283 to 354)

Closed-Loop Crimp Terminal Recommendations

Yaskawa recommends UL-listed crimp terminals made by JST and Tokyo DIP (or equivalent) for the insulation cap. [Table D.7](#) matches the wire gauges and terminal screw sizes with Yaskawa-recommended crimp terminals, tools, and insulation caps. Refer to the appropriate Wire Gauge and Torque Specifications table for the wire gauge and screw size for your drive model. Place orders with a Yaskawa representative or the Yaskawa sales department.

The closed-loop crimp terminal sizes and values listed in [Table D.7](#) are Yaskawa recommendations.

Wire gauge values shown in *bold italic* are the recommended values. Refer to local codes for proper selections.

Table D.7 Closed-Loop Crimp Terminal Size

Drive Model	Wire Gauge (AWG, kcmil)		Screw Size	Crimp Terminal Model Number	Tool		Insulation Cap Model No.	Code <1>
	R/L1, S/L2, T/L3	U/T1, V/T2, W/T3			Machine No.	Die Jaw		
200 V Class								
2A0004 2A0006 2A0008 2A0010	<i>14</i>		M4	R2-4	YA-4	AD-900	TP-003	100-054-028
	12			R5.5-4			TP-005	100-054-029
	10							

D.3 UL and CSA Standards

Drive Model	Wire Gauge (AWG, kcmil)		Screw Size	Crimp Terminal Model Number	Tool		Insulation Cap Model No.	Code <?>
	R/L1, S/L2, T/L3	U/T1, V/T2, W/T3			Machine No.	Die Jaw		
2A0012	14	14	M4	R2-4	YA-4	AD-900	TP-003	100-054-028
	12	12		R5.5-4			TP-005	100-054-029
	10							
2A0018	–	14	M4	R2-4	YA-4	AD-900	TP-003	100-054-028
	12			R5.5-4			TP-005	100-054-029
	10							
2A0021	12		M4	R5.5-4	YA-4	AD-900	TP-005	100-054-029
	10							
2A0030	10		M4	R5.5-4	YA-4	AD-900	TP-005	100-054-029
	8			8-4		AD-901	TP-008	100-054-031
	6			14-NK4		AD-902	TP-014	100-054-033
2A0040	8	8	M4	8-4	YA-4	AD-901	TP-008	100-054-031
	6	6		14-NK4		AD-902	TP-014	100-054-033
2A0056	6		M6	R14-6	YA-5	AD-952	TP-014	100-051-261
	4			R22-6		AD-953	TP-022	100-051-262
2A0069	4		M8	R22-8	YA-5	AD-953	TP-022	100-051-263
	3			R38-8		AD-954	TP-038	100-051-264
2A0081	3		M8	R38-8	YA-5	AD-954	TP-038	100-051-264
	2							
2A0110	3		M8	R38-8	YA-5	AD-954	TP-038	100-051-264
	2							
	1							
	1/0							
2A0138	1		M10	R38-10	YF-1 YET-300-1	TD-321, TD-311	TP-060	100-061-114
	1/0			R60-10				100-051-266
	2/0			70-10				TD-323, TD-312
2A0169	2/0	–	M10	70-10	YF-1 YET-300-1	TD-323, TD-312	TP-080	100-054-036
	3/0			80-10				100-051-267
	4/0			R100-10				TD-324, TD-312
2A0211	1/0 × 2P		M10	R60-10	YF-1 YET-300-1	TD-321, TD-311	TP-060	100-051-266
	2/0 × 2P			70-10				
2A0250	3/0 × 2P		M12	80-L12	YF-1 YET-300-1	TD-323, TD-312	TP-080	100-051-558
	4/0 × 2P			100-L12		TD-324, TD-312	TP-100	100-051-560
	–	250 × 2P		150-L12		TD-325, TD-313	TP-150	100-051-562
	250	–		R150-12			TP-150	100-051-273
	300							
2A0312	3/0 × 2P	3/0 × 2P	M12	80-L12	YF-1 YET-300-1	TD-323, TD-312	TP-080	100-051-558
	4/0 × 2P	4/0 × 2P		100-L12		TD-324, TD-312	TP-100	100-051-560
	250 × 2P			150-L12		TD-325, TD-313	TP-150	100-051-562
	300 × 2P							

Drive Model	Wire Gauge (AWG, kcmil)		Screw Size	Crimp Terminal Model Number	Tool		Insulation Cap Model No.	Code <1>
	R/L1, S/L2, T/L3	U/T1, V/T2, W/T3			Machine No.	Die Jaw		
2A0360	4/0 × 2P	4/0 × 2P	M12	100-L12	YF-1 YET-300-1	TD-324, TD-312	TP-100	100-051-560
	250 × 2P	250 × 2P		150-L12		TD-325, TD-313	TP-150	100-051-562
	300 × 2P			180-L12		TD-327, TD-314	TP-200	100-066-688
	350 × 2P			200-L12				100-051-564
	400 × 2P			325-12		TD-328, TD-315	TP-325	100-051-277
	500 × 2P							
2A0415	250 × 2P	–	M12	150-L12	YF-1 YET-300-1	TD-325, TD-313	TP-150	100-051-562
	300 × 2P	300 × 2P		180-L12		TD-327, TD-314	TP-200	100-066-688
	350 × 2P	350 × 2P		200-L12				100-051-564
	400 × 2P			325-12		TD-328, TD-315	TP-325	100-051-277
	500 × 2P							
	600 × 2P							
400 V Class								
4A0002 4A0004 4A0005 4A0007 4A0009	14		M4	R2-4	YA-4	AD-900	TP-003	100-054-028
12		R5.5-4		TP-005			100-054-029	
10								
4A0011	14	14	M4	R2-4	YA-4	AD-900	TP-003	100-054-028
	12	12		R5.5-4			TP-005	100-054-029
	10							
4A0018	12		M4	R5.5-4	YA-4	AD-900	TP-005	100-054-029
	10			8-4		AD-901	TP-008	100-054-031
	8			14-NK4		AD-902	TP-014	100-054-033
	6							
4A0023	10		M4	R5.5-4	YA-4	AD-900	TP-005	100-054-029
	8			8-4		AD-901	TP-008	100-054-031
	6			14-NK4		AD-902	TP-014	100-054-033
4A0031	–	10	M5	R5.5-5	YA-4	AD-900	TP-005	100-054-030
	8			R8-5		AD-901	TP-008	100-054-032
	6			R14-5		AD-902	TP-014	100-054-034
4A0038	8	8	M5	R8-5	YA-4	AD-901	TP-008	100-054-032
	6	6		R14-5		AD-902	TP-014	100-054-034
4A0044	6		M6	R14-6	YA-5	AD-952	TP-014	100-051-261
	4			R22-6		AD-953	TP-022	100-051-262
4A0058	6		M8	R14-8	YA-5	AD-952	TP-014	100-054-035
	4			R22-8		AD-953	TP-022	100-051-263
4A0072	4		M8	R22-8	YA-5	AD-953	TP-022	100-051-263
	3			R38-8		AD-954	TP-038	100-051-264
4A0088	3		M8	R38-8	YA-5	AD-954	TP-038	100-051-264
	2							
	1							
	1/0							
4A0103	2		M8	R38-8	YA-5	AD-954	TP-038	100-051-264
	1	1						
	1/0	1/0						

D.3 UL and CSA Standards

Drive Model	Wire Gauge (AWG, kcmil)		Screw Size	Crimp Terminal Model Number	Tool		Insulation Cap Model No.	Code <1>	
	R/L1, S/L2, T/L3	U/T1, V/T2, W/T3			Machine No.	Die Jaw			
4A0139	1/0		M10	R60-10	YF-1 YET-300-1	TD-321, TD-311	TP-060	100-051-266	
	2/0	2/0		70-10		TD-323, TD-312	TP-080	100-054-036	
	3/0	3/0		80-10				100-051-267	
	4/0			R100-10		TD-324, TD-312	TP-100	100-051-269	
4A0165	3/0		M10	80-10	YF-1 YET-300-1	TD-323, TD-312	TP-080	100-051-267	
	4/0			R100-10		TD-324, TD-312	TP-100	100-051-269	
4A0208	2 × 2P		M10	38-L10	YF-1 YET-150-1	TD-224, TD-212	TP-038	100-051-556	
	1 × 2P			80-L10		TD-227, TD-214	TP-080	100-051-557	
	3/0 × 2P			R100-10		TD-228, TD-214	TP-100	100-051-269	
	4/0			R150-10		TD-229, TD-215	TP-150	100-051-272	
	250								
	300								
4A0250	1 × 2P	–	M10	38-L10	YF-1 YET-150-1	TD-224, TD-212	TP-038	100-051-556	
	3/0 × 2P			80-L10		TD-227, TD-214	TP-080	100-051-557	
	4/0 × 2P			100-L10		TD-228, TD-214	TP-100	100-051-559	
	250 × 2P			150-L10		TD-229, TD-215	TP-150	100-051-561	
	300			R150-10			TP-150	100-051-272	
	350			180-10	YF-1 YET-300-1	TD-327, TD-314	TP-200	100-066-687	
	400			200-10		TD-328, TD-315	TP-325	100-051-565	
	500								
	600								
4A0296	3/0 × 2P		M12	80-L12	YF-1 YET-300-1	TD-323, TD-312	TP-080	100-051-558	
	4/0 × 2P			100-L12		TD-324, TD-312	TP-100	100-051-560	
	250 × 2P			150-L12		TD-325, TD-313	TP-150	100-051-562	
	300 × 2P			180-L12		TD-327, TD-314	TP-200	100-066-688	
	–	350 × 2P		180-12				100-066-689	
	350	–		R200-12				100-051-275	
	400								
	500								
	600					325-12	TD-328, TD-315	TP-325	100-051-277
4A0362	3/0 × 2P		M12	80-L12	YF-1 YET-300-1	TD-323, TD-312	TP-080	100-051-558	
	4/0 × 2P			100-L12		TD-324, TD-312	TP-100	100-051-560	
	250 × 2P			150-L12		TD-325, TD-313	TP-150	100-051-562	
	300 × 2P			180-L12		TD-327, TD-314	TP-200	100-066-688	
	350 × 2P			200-L12				100-051-564	
	400 × 2P								
	500					325-12	TD-328, TD-315	TP-325	100-051-277
	600								
4A0414	4/0 × 2P		M12	100-L12	YF-1 YET-300-1	TD-324, TD-312	TP-100	100-051-560	
	250 × 2P			150-L12		TD-325, TD-313	TP-150	100-051-562	
	300 × 2P								

Drive Model	Wire Gauge (AWG, kcmil)		Screw Size	Crimp Terminal Model Number	Tool		Insulation Cap Model No.	Code <1>
	R/L1, S/L2, T/L3	U/T1, V/T2, W/T3			Machine No.	Die Jaw		
4A0515	3/0 × 4P	3/0 × 4P	M12	80-L12	YF-1 YET-300-1	TD-323, TD-312	TP-080	100-051-558
	4/0 × 4P	4/0 × 4P		100-L12		TD-324, TD-312	TP-100	100-051-560
	250 × 4P			150-L12		TD-325, TD-313	TP-150	100-051-562
	300 × 2P							
4A0675	4/0 × 4P		M12	100-L12	YF-1 YET-300-1	TD-324, TD-312	TP-100	100-051-560
	250 × 4P			150-L12		TD-325, TD-313	TP-150	100-051-562
	300 × 4P							
4A0930	3/0 × 8P		M12	80-L12	YF-1 YET-300-1	TD-323, TD-312	TP-080	100-051-558
	4/0 × 8P			100-L12		TD-324, TD-312	TP-100	100-051-560
	250 × 8P			150-L12		TD-325, TD-313	TP-150	100-051-562
	300 × 8P							
4A1200	4/0 × 8P		M12	100-L12	YF-1 YET-300-1	TD-324, TD-312	TP-100	100-051-560
	250 × 8P			150-L12		TD-325, TD-313	TP-150	100-051-562
	300 × 8P							

<1> Codes refer to a set of three crimp terminals and three insulation caps. Prepare input and output wiring using two sets for each connection.
 Example 1: Models with 300 kcmil for both input and output require one set for input terminals and one set for output terminals, so the user should order two sets of [100-051-272].
 Example 2: Models with 4/0 AWG × 2P for both input and output require two sets for input terminals and two sets for output terminals, so the user should order four sets of [100-051-560].

Note: Use crimp insulated terminals or insulated shrink tubing for wiring connections. Wires should have a continuous maximum allowable temperature of 75 °C 600 Vac UL-approved vinyl-sheathed insulation.

Input Fuse Installation

Yaskawa recommends installing one of the following types of branch circuit protection to maintain compliance with UL508C. Semiconductor protective type fuses are preferred. Alternate branch circuit protection devices are also listed in [Table 8.12](#) and [Table 8.13](#).

Table D.8 Factory Recommended A1000 AC Drive Branch Circuit Protection (Normal Duty)

Drive Model	A1000 in Normal Duty Mode (C6-01 = 1)					
	Nominal Output Power HP	AC Drive Input Amps	MCCB Rating Amps <1>	Time Delay Fuse Rating Amps <2>	Non-time Delay Fuse Rating Amps <3>	Bussman Semiconductor Fuse Rating (Fuse Ampere) <4>
200 V Class						
2A0004	0.75	3.9	15	6.25	10	FWH-70B (70)
2A0006	1 - 1.5	7.3	15	12	20	FWH-70B (70)
2A0008	2	8.8	15	15	25	FWH-70B (70)
2A0010	3	10.8	20	17.5	30	FWH-70B (70)
2A0012	3	13.9	25	20	40	FWH-70B (70)
2A0018	5	18.5	35	30	50	FWH-90B(90)
2A0021	7.5	24	45	40	70	FWH-90B(90)
2A0030	10	37	60	60	110	FWH-100B (100)
2A0040	15	52	100	90	150	FWH-200B (200)
2A0056	20	68	125	110	200	FWH-200B (200)
2A0069	25	80	150	125	225	FWH-200B (200)
2A0081	30	96	175	150	275	FWH-300A (300)
2A0110	40	111	200	175	300	FWH-300A (300)
2A0138	50	136	250	225	400	FWH-350A (350)

D.3 UL and CSA Standards

Drive Model	A1000 in Normal Duty Mode (C6-01 = 1)					
	Nominal Output Power HP	AC Drive Input Amps	MCCB Rating Amps <1>	Time Delay Fuse Rating Amps <2>	Non-time Delay Fuse Rating Amps <3>	Bussman Semiconductor Fuse Rating (Fuse Ampere) <4>
2A0169	60	164	300	250	450	FWH-400A (400)
2A0211	75	200	400	350	600	FWH-400A (400)
2A0250	100	271	500	450	800	FWH-600A (600)
2A0312	125	324	600	500	800	FWH-700A (700)
2A0360	150	394	700	600	1000 <5>	FWH-800A (800)
2A0415	175	471	900	800	1400 <5>	FWH-1000A (1000)
400 V Class						
4A0002	1	2.1	15	3.5	6	FWH-40B (40)
4A0004	2	4.3	15	7.5	12	FWH-50B (50)
4A0005	3	5.9	15	10	17.5	FWH-70B (70)
4A0007	3	8.1	15	12	20	FWH-70B (70)
4A0009	5	9.4	15	15	25	FWH-90B (90)
4A0011	7.5	14	25	20	40	FWH-90B (90)
4A0018	10	20	40	35	60	FWH-80B (80)
4A0023	15	24	45	40	70	FWH-100B (100)
4A0031	20	38	75	60	110	FWH-125B (125)
4A0038	25	44	75	75	125	FWH-200B (200)
4A0044	30	52	100	90	150	FWH-250A (250)
4A0058	40	58	100	100	150	FWH-250A (250)
4A0072	50	71	125	110	200	FWH-250A (250)
4A0088	60	86	150	150	250	FWH-250A (250)
4A0103	75	105	200	175	300	FWH-250A (250)
4A0139	100	142	250	225	400	FWH-350A (350)
4A0165	125	170	300	250	500	FWH-400A (400)
4A0208	150	207	400	350	600	FWH-500A (500)
4A0250	200	248	450	400	700	FWH-600A (600)
4A0296	250	300	600	500	800	FWH-700A (700)
4A0362	300	346	600	600	1000 <5>	FWH-800A (800)
4A0414	350	410	800	700	1200 <5>	FWH-800A (800)
4A0515	400 - 450	465	900	800	1350 <5>	FWH-1000A (1000)
4A0675	500 - 600	657	1200	1100 <5>	1800 <5>	FWH-1200A (1200)
4A0930	700 - 800	922	Not Applicable			FWH-1200A (1200)
4A1200	900 - 1000	1158				FWH-1600A (1600)
600 V Class						
5A0003	2	3.6	15	6.25	10	FWP-50B (50)
5A0004	3	5.1	15	8	15	FWP-50B (50)
5A0006	5	8.3	15	12	20	FWP-60B (60)
5A0009	7.5	12	20	20	35	FWP-60B (60)
5A0011	10	16	30	25	45	FWP-70B (70)
5A0017	15	23	40	40	60	FWP-100B (100)
5A0022	20	31	60	50	90	FWP-100B (100)
5A0027	25	38	75	60	110	FWP-125A (125)
5A0032	30	45	75	75	125	FWP-125A (125)
5A0041	40	44	75	75	125	FWP-175A (175)
5A0052	50	54	100	90	150	FWP-175A (175)
5A0062	60	66	125	110	175	FWP-250A (250)

Drive Model	A1000 in Normal Duty Mode (C6-01 = 1)					
	Nominal Output Power HP	AC Drive Input Amps	MCCB Rating Amps <1>	Time Delay Fuse Rating Amps <2>	Non-time Delay Fuse Rating Amps <3>	Bussman Semiconductor Fuse Rating (Fuse Ampere) <4>
5A0077	75	80	150	125	225	FWP-250A (250)
5A0099	100	108	175	175	300	FWP-250A (250)
5A0125	125	129	225	225	350	FWP-350A (350)
5A0145	150	158	300	275	450	FWP-350A (350)
5A0192	200	228	400	350	600	FWP-600A (600)
5A0242	250	263	500	450	700	FWP-600A (600)

- <1> Maximum MCCB Rating is 15 A, or 200 % of drive input current rating, whichever is larger. MCCB voltage rating must be 600 VAC or greater.
- <2> Maximum Time Delay fuse is 175% of drive input current rating. This covers any Class CC, J or T class fuse.
- <3> Maximum Non-time Delay fuse is 300% of drive input current rating. This covers any CC, J or T class fuse.
- <4> When using semiconductor fuses, Bussman FWH and FWP are required for UL compliance. Select FWH for 200 V Class and 400 V Class models and FWP fuses for 600 V models.
- <5> Class L fuse is also approved for this rating.

Table D.9 Factory Recommended A1000 AC Drive Branch Circuit Protection (Heavy Duty)

Drive Model	A1000 in Heavy Duty Mode (C6-01 = 0)					
	Nominal Output Power HP	AC Drive Input Amps	MCCB Rating Amps <1>	Time Delay Fuse Rating Amps <2>	Non-time Delay Fuse Rating Amps <3>	Bussman Semiconductor Fuse Rating (Fuse Ampere) <4>
200 V Class						
2A0004	0.75	2.9	15	5	8	FWH-70B (70)
2A0006	1	5.8	15	10	15	FWH-70B (70)
2A0008	2	7	15	12	17.5	FWH-70B (70)
2A0010	2	7.5	15	12	20	FWH-70B (70)
2A0012	3	11	20	17.5	30	FWH-70B (70)
2A0018	3	15.6	25	25	40	FWH-90B(90)
2A0021	5	18.9	35	30	50	FWH-90B(90)
2A0030	7.5	28	50	40	75	FWH-100B (100)
2A0040	10	37	60	60	100	FWH-200B (200)
2A0056	15	52	100	90	150	FWH-200B (200)
2A0069	20	68	125	110	200	FWH-200B (200)
2A0081	25	80	150	125	225	FWH-300A (300)
2A0110	30	82	150	125	225	FWH-300A (300)
2A0138	40	111	200	175	250	FWH-350A (350)
2A0169	50	136	250	225	350	FWH-400A (400)
2A0211	60	164	300	250	450	FWH-400A (400)
2A0250	75	200	400	350	600	FWH-600A (600)
2A0312	100	271	500	450	800	FWH-700A (700)
2A0360	125	324	600	500	900 <4>	FWH-800A (800)
2A0415	150	394	700	600	1100 <4>	FWH-1000A (1000)
400 V Class						
4A0002	0.75	1.8	15	3	5	FWH-40B (40)
4A0004	1 - 2	3.2	15	5	9	FWH-50B (50)
4A0005	3	4.4	15	7	12	FWH-70B (70)
4A0007	3	6	15	10	17.5	FWH-70B (70)
4A0009	5	8.2	15	12	20	FWH-90B (90)
4A0011	5	10.4	20	17.5	30	FWH-90B (90)
4A0018	7.5 - 10	15	30	25	40	FWH-80B (80)

D.3 UL and CSA Standards

Drive Model	A1000 in Heavy Duty Mode (C6-01 = 0)					
	Nominal Output Power HP	AC Drive Input Amps	MCCB Rating Amps <1>	Time Delay Fuse Rating Amps <2>	Non-time Delay Fuse Rating Amps <3>	Bussman Semiconductor Fuse Rating (Fuse Ampere) <4>
4A0023	10	20	40	35	60	FWH-100B (100)
4A0031	15	29	50	50	80	FWH-125B (125)
4A0038	20	39	75	60	110	FWH-200B (200)
4A0044	25 - 30	47	75	75	125	FWH-250A (250)
4A0058	30	43	75	75	125	FWH-250A (250)
4A0072	40	58	100	100	150	FWH-250A (250)
4A0088	60	71	125	110	200	FWH-250A (250)
4A0103	60	86	150	150	250	FWH-250A (250)
4A0139	75	105	175	175	300	FWH-350A (350)
4A0165	100	142	225	225	400	FWH-400A (400)
4A0208	125 - 150	170	250	250	500	FWH-500A (500)
4A0250	150	207	350	350	600	FWH-600A (600)
4A0296	200	248	400	400	700	FWH-700A (700)
4A0362	250	300	500	500	800	FWH-800A (800)
4A0414	300	346	600	600	1000 <4>	FWH-800A (800)
4A0515	350	410	700	700	1200 <4>	FWH-1000A (1000)
4A0675	400 - 500	584	1000	1000 <4>	1600 <4>	FWH-1200A (1200)
4A0930	600 - 700	830	Not Applicable			FWH-1200A (1200)
4A1200	800 - 900	1031				FWH-1600A (1600)
600 V Class						
5A0003	1	1.9	15	3	5	FWP-50B (50)
5A0004	2	3.6	15	6.25	10	FWP-50B (50)
5A0006	3	5.1	15	8	15	FWP-60B (60)
5A0009	5	8.3	15	12	20	FWP-60B (60)
5A0011	7.5	12	20	20	35	FWP-70B (70)
5A0017	10	16	30	25	45	FWP-100B (100)
5A0022	15	23	40	40	60	FWP-100B (100)
5A0027	20	31	60	50	90	FWP-125A (125)
5A0032	25	38	75	60	100	FWP-125A (125)
5A0041	30	33	60	50	90	FWP-175A (175)
5A0052	40	44	75	75	125	FWP-175A (175)
5A0062	50	54	100	90	150	FWP-250A (250)
5A0077	60	66	125	110	175	FWP-250A (250)
5A0099	75	80	150	125	225	FWP-250A (250)
5A0125	100	108	175	175	300	FWP-350A (350)
5A0145	125	129	250	225	350	FWP-350A (350)
5A0192	150	158	300	250	400	FWP-600A (600)
5A0242	200	228	400	350	600	FWP-600A (600)

<1> Maximum MCCB Rating is 15 A, or 200 % of drive input current rating, whichever is larger. MCCB voltage rating must be 600 VAC or greater.

<2> Maximum Time Delay fuse is 175% of drive input current rating. This covers any Class CC, J or T class fuse.

<3> Maximum Non-time Delay fuse is 300% of drive input current rating. This covers any CC, J or T class fuse.

<4> Class L fuse is also approved for this rating.

■ Low Voltage Wiring for Control Circuit Terminals

Wire low voltage wires with NEC Class 1 circuit conductors. Refer to national state or local codes for wiring. The external power supply shall be a UL listed Class 2 power supply source or equivalent only.

Table D.10 Control Circuit Terminal Power Supply

Input / Output	Terminal Signal	Power Supply Specifications
Open Collector Outputs	P1, P2, PC, DM+, DM-	Requires class 2 power supply
Digital inputs	S1 to S8, SC, HC, H1, H2	Use the internal LVLC power supply of the drive. Use class 2 for external power supply.
Analog inputs / outputs	+V, -V, A1, A2, A3, AC, AM, FM	Use the internal LVLC power supply of the drive. Use class 2 for external power supply.

■ Drive Short Circuit Rating

The drive is suitable for use on a circuit capable of delivering not more than 100,000 RMS symmetrical Amperes, 240 Vac maximum (200 V Class), 480 Vac maximum (400 V Class), and 600 Vac maximum (600 V Class) when protected by Bussmann Type FWH or FWP fuses as specified in [Factory Recommended Branch Circuit Protection](#) on page 648.

◆ CSA Standards Compliance



Figure D.7 CSA Mark

■ CSA for Industrial Control Equipment

The drive is CSA-certified as Industrial Control Equipment Class 3211.

Specifically, the drive is certified to: CAN/CSA C22.2 No. 04-04 and CAN/CSA C22.2 No.14-05.

◆ Drive Motor Overload Protection

Set parameter E2-01 (motor rated current) to the appropriate value to enable motor overload protection. The internal motor overload protection is UL listed and in accordance with the NEC and CEC.

■ E2-01: Motor Rated Current

Setting Range: Model-dependent

Default Setting: Model-dependent

Parameter E2-01 protects the motor when parameter L1-01 is not set to 0. The default for L1-01 is 1, which enables protection for standard induction motors.

If Auto-Tuning has been performed successfully, the motor data entered to T1-04 is automatically written to parameter E2-01. If Auto-Tuning has not been performed, manually enter the correct motor rated current to parameter E2-01.

■ L1-01: Motor Overload Protection Selection

The drive has an electronic overload protection function (oL1) based on time, output current, and output frequency that protects the motor from overheating. The electronic thermal overload function is UL-recognized, so it does not require an external thermal relay for single motor operation.

This parameter selects the motor overload curve used according to the type of motor applied.

Table D.11 Overload Protection Settings

Setting	Description	
0	Disabled	Disabled the internal motor overload protection of the drive.
1	Standard fan-cooled motor (default)	Selects protection characteristics for a standard self-cooled motor with limited cooling capabilities when running below the rated speed. The motor overload detection level (oL1) is automatically reduced when running below the motor rated speed.
2	Drive duty motor with a speed range of 1:10	Selects protection characteristics for a motor with self-cooling capability within a speed range of 10:1. The motor overload detection level (oL1) is automatically reduced when running below 1/10 of the motor rated speed.
3	Vector motor with a speed range of 1:100	Selects protection characteristics for a motor capable of cooling itself at any speed including zero speed (externally cooled motor). The motor overload detection level (oL1) is constant over the entire speed range.
4	Permanent Magnet motor with variable torque	Selects protection characteristics for a variable torque PM motor. The motor overload detection level (oL1) is automatically reduced when running below the motor rated speed.
5	Permanent Magnet motor with constant torque	Selects protection characteristics for a constant torque PM motor. The motor overload detection level (oL1) is constant over the whole speed range.
6	Standard fan-cooled motor (50 Hz)	Selects protection characteristics for a standard self-cooled motor with limited cooling capabilities when running below the rated speed. The motor overload detection level (oL1) is automatically reduced when running below the motor rated speed.

When connecting the drive to more than one motor for simultaneous operation, disable the electronic overload protection (L1-01 = 0) and wire each motor with its own motor thermal overload relay.

Enable motor overload protection (L1-01 = 1 to 6) when connecting the drive to a single motor, unless another motor overload preventing device is installed. The drive electronic thermal overload function causes an oL1 fault, which shuts off the output of the drive and prevents additional overheating of the motor. The motor temperature is continually calculated while the drive is powered up.

■ L1-02: Motor Overload Protection Time

Setting Range: 0.1 to 5.0 min

Factory Default: 1.0 min

Parameter L1-02 determines how long the motor is allowed to operate before the oL1 fault occurs when the drive is running at 60 Hz and at 150% of the full load amp rating (E2-01) of the motor. Adjusting the value of L1-02 can shift the set of oL1 curves up the y axis of the diagram below, but will not change the shape of the curves.

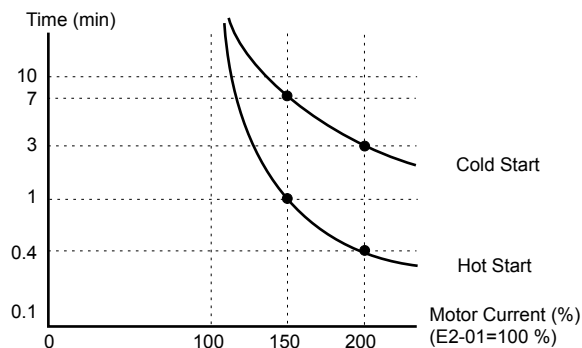

Figure D.8 Motor Overload Protection Time

◆ Precautionary Notes on External Heatsink (IP00/Open Type Enclosure)

When using an external heatsink, UL compliance requires covering exposed capacitors in the main circuit to prevent injury to surrounding personnel.

The portion of the external heatsink that projects out can be protected with the enclosure or with the appropriate capacitor cover after completing drive installation. Use [Table D.12](#) to match drive models with available capacitor covers. Order capacitor covers from a Yaskawa representative or directly from the Yaskawa sales department.

Table D.12 Capacitor Cover

Drive Model	Code Number	Model	Figure	
2A0110	100-061-273	ECAT31875-11	<i>Figure D.9</i>	
2A0138	100-061-274	ECAT31876-11		
2A0169	100-061-275	ECAT31877-11		
2A0211				
2A0250	100-061-277	ECAT31726-11		
2A0312				
2A0360	100-061-278	ECAT31698-11		
2A0415				
4A0058	100-061-273	ECAT31875-11		
4A0072	100-061-274	ECAT31876-11		
4A0088	100-061-276	ECAT31878-11		
4A0103				
4A0139	100-061-275	ECAT31877-11		
4A0165				
4A0208	100-061-277	ECAT31726-11		
4A0250	100-061-278	ECAT31698-11		
4A0296				
4A0362				
4A0414	100-061-279	ECAT31740-11		
4A0515	100-061-280	ECAT31746-11		
4A0675				
4A0930	100-061-281 ^{<1>}	ECAT31741-11		<i>Figure D.10</i>
4A1200				
5A0041	100-061-274	ECAT31876-11		<i>Figure D.9</i>
5A0052				
5A0062	100-061-275	ECAT31877-11		
5A0077				
5A0099				
5A0125	100-061-277	ECAT31726-11		
5A0145				
5A0192	100-061-278	ECAT31698-11		
5A0242				

<1> Requires two sets.

Note: Model 4A1200 is UL compliant when the air entering the drive-installed panel or cabinet is 45 °C or cooler. For more information, contact your nearest Yaskawa representative or our sales office.

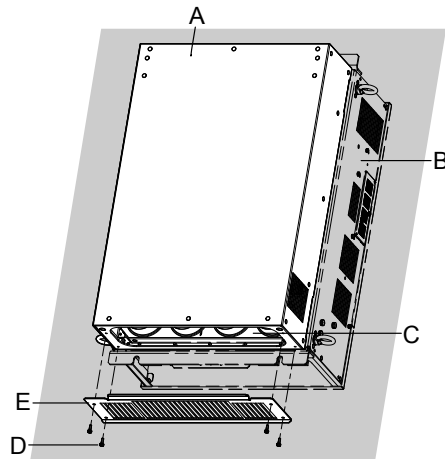

- A – Drive (outside panel)
- B – Drive (inside panel)
- C – Opening to capacitors
- D – Installation screws
- E – Capacitor cover

Figure D.9 Capacitor Cover

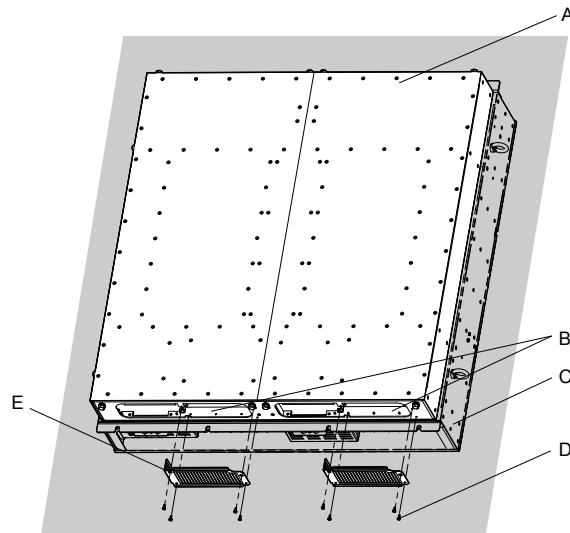

- A – Drive (outside panel)
- B – Opening to capacitors
- C – Drive (inside panel)
- D – Installation screws
- E – Capacitor cover

Figure D.10 Capacitor Cover (Models 4A0930, 4A1200)

D.4 Safe Disable Input Function

◆ Specifications

Inputs/Outputs		Two Safe Disable inputs and one EDM output according to ISO13849–1 Cat. 3 PLd, IEC61508 SIL2. <I>
Operation Time		Time from input open to drive output stop is less than 1 ms.
Failure Probability	Demand Rate Low	PFD = 5.15E ⁻⁵
	Demand Rate High/Continuous	PFH = 1.2E ⁻⁹
Performance Level		The Safe Disable inputs satisfy all requirements of Performance Level (PL) d according to ISO13849-1 (DC from EDM considered). <I>

<I> Terminals H1, H2, DM+, and DM- on 600 V class models are designed to the functionality, but are not certified to EN61800-5-1, ISO13849 Cat. 3, IEC/EN61508 SIL2, Insulation coordination: class 1.

◆ Precautions

Note: Terminals H1, H2, DM+, and DM- on 600 V class models are designed to the functionality, but are not certified to EN61800-5-1, ISO13849 Cat. 3, IEC/EN61508 SIL2, Insulation coordination: class 1.

DANGER! *Sudden Movement Hazard. Improper use of the Safe Disable function can result in serious injury or even death. Make sure the whole system or machinery in which the Safe Disable function is used complies with safety requirements. When implementing the Safe Disable function into the safety system of a machine, perform a thorough risk assessment for the entire system to assure compliance with relevant safety norms.*

DANGER! *Sudden Movement Hazard. When using a PM motor, even if the drive output is shut off by the Safe Disable function, a breakdown of two output transistors can cause current to flow through the motor winding, resulting in a rotor movement for a maximum angle of 180 degrees (electrically). Make sure such a situation would have no effect on the safety of the application when using the Safe Disable function.*

DANGER! *Sudden Movement Hazard. The Safe Disable function can switch off the drive output, but does not cut the drive power supply and cannot electrically isolate the drive output from the input. Always shut off the drive power supply when performing maintenance or installations on the drive input side as well as the drive output side.*

WARNING! *Sudden Movement Hazard. When using the Safe Disable inputs, make sure to remove the wire links between terminals H1, H2, and HC that were installed prior to shipment. Failing to do so will keep the Safe Disable circuit from operating properly and can cause injury or even death.*

NOTICE: *All safety features (including Safe Disable) should be inspected daily and periodically. If the system is not operating normally, there is a risk of serious personal injury.*

NOTICE: *Only a qualified technician with a thorough understanding of the drive, the instruction manual, and safety standards should be permitted to wire, inspect, and maintain the Safe Disable input.*

NOTICE: *From the moment terminal inputs H1 and H2 have opened, it takes up to 1 ms for drive output to shut off completely. The sequence set up to trigger terminals H1 and H2 should make sure that both terminals remain open for at least 1 ms in order to properly interrupt drive output.*

NOTICE: *The Safe Disable Monitor (output terminals DM+ and DM-) should not be used for any other purpose than to monitor the Safe Disable status or to discover a malfunction in the Safe Disable inputs. The monitor output is not considered a safe output.*

NOTICE: *When utilizing the Safe Disable function, use only the EMC filters recommended in [EMC Filters](#) on page 653.*

◆ Using the Safe Disable Function

Note: Terminals H1, H2, DM+, and DM- on 600 V class models are designed to the functionality, but are not certified to EN61800-5-1, ISO13849 Cat. 3, IEC/EN61508 SIL2, Insulation coordination: class 1.

The Safe Disable inputs provide a stop function in compliance with “Safe Torque Off” as defined in the IEC61800-5-2. Safe Disable inputs have been designed to meet the requirements of the ISO13849-1, Category 3 PLd, and IEC61508, SIL2.

A Safe Disable Status Monitor for error detection in the safety circuit is also provided.

■ Safe Disable Circuit

Note: Terminals H1, H2, DM+, and DM- on 600 V class models are designed to the functionality, but are not certified to EN61800-5-1, ISO13849 Cat. 3, IEC/EN61508 SIL2, Insulation coordination: class 1.

The Safe Disable circuit consists of two independent input channels that can block the output transistors and provide a monitoring channel to indicate the status of those input channels.

D.4 Safe Disable Input Function

The input can use the internal power supply of the drive or an external power supply and it will support Sink mode or Source mode. The mode selected for the digital input terminals S1 to S8 by switch S3 will also be used for the Safe Disable inputs. [Refer to Sinking/Sourcing Mode Switch for Digital Inputs on page 104](#) for more information.

The Safe Disable Monitor uses a single channel photocoupler output. [Refer to Output Terminals on page 99](#) for signal specifications when using this output.

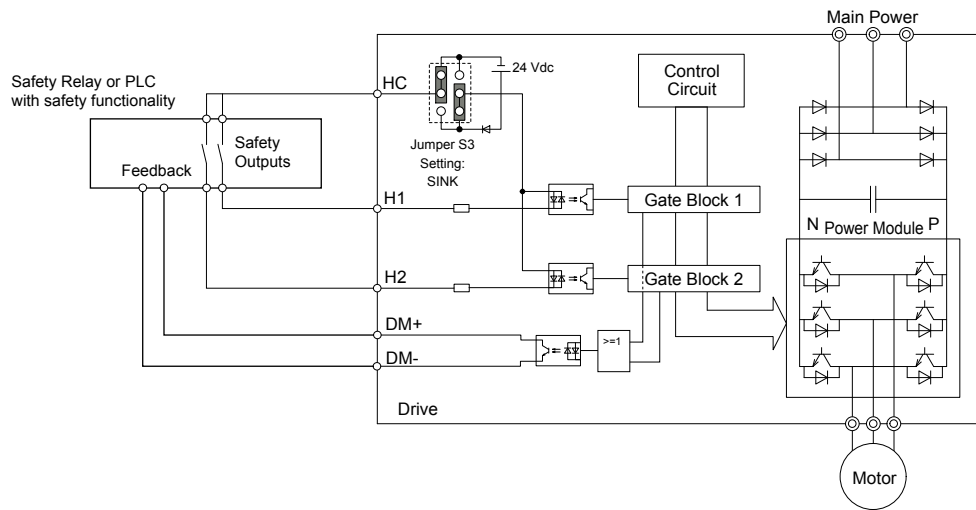

Figure D.11 Safe Disable Function Wiring Example (SINK Mode)

Disabling and Enabling the Drive Output (“Safe Torque Off”)

Note: Terminals H1, H2, DM+, and DM- on 600 V class models are designed to the functionality, but are not certified to EN61800-5-1, ISO13849 Cat. 3, IEC/EN61508 SIL2, Insulation coordination: class 1.

[Figure D.12](#) illustrates the Safe Disable input operation.

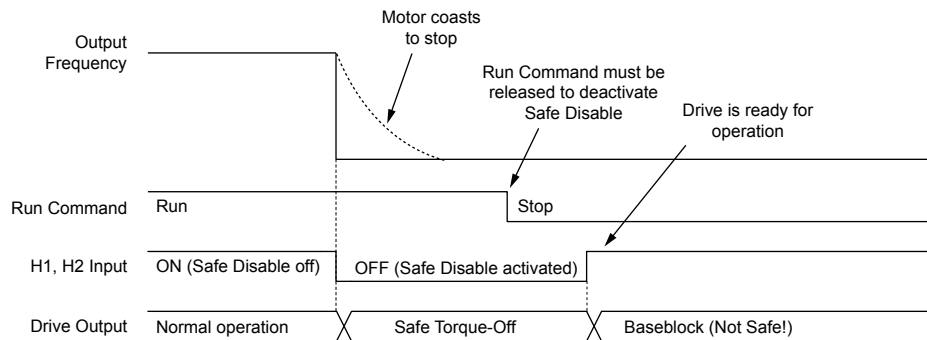

Figure D.12 Safe Disable Operation

Entering the “Safe Torque Off” State

Note: Terminals H1, H2, DM+, and DM- on 600 V class models are designed to the functionality, but are not certified to EN61800-5-1, ISO13849 Cat. 3, IEC/EN61508 SIL2, Insulation coordination: class 1.

Whenever either one Safe Disable input or both inputs open, the motor torque is shut off by switching off the drive output. If the motor was running before the Safe Disable inputs opened, then the motor will coast to stop, regardless of the stopping method set in parameter b1-03.

Notice that the “Safe Torque Off” state can only be achieved using the Safe Disable function. Removing the Run command stops the drive and shuts the output off (baseblock), but does not create a “Safe Torque Off” status.

Note: To avoid an uncontrolled stop during normal operation, make sure that the Safe Disable inputs are opened first when the motor has completely stopped.

Returning to Normal Operation after Safe Disable

Note: Terminals H1, H2, DM+, and DM- on 600 V class models are designed to the functionality, but are not certified to EN61800-5-1, ISO13849 Cat. 3, IEC/EN61508 SIL2, Insulation coordination: class 1.

The Safe Disable function can only be deactivated when a Run command is not active.

If Safe Disable was activated during stop, turn on both Safe Disable inputs by deactivating “Safe Torque Off” to resume normal operation.

If Safe Disable was activated during run, remove the Run command then turn on the Safe Disable inputs before restarting the drive.

■ **Safe Disable Monitor Output Function and Digital Operator Display**

Note: Terminals H1, H2, DM+, and DM- on 600 V class models are designed to the functionality, but are not certified to EN61800-5-1, ISO13849 Cat. 3, IEC/EN61508 SIL2, Insulation coordination: class 1.

Table D.13 explains the drive output and Safe Disable monitor state depending on the Safe Disable inputs.

Table D.13 Safety Input and EDM Terminal Status

Safe Disable Input Status		Safe Disable Status Monitor, DM+ DM-	Drive Output Status	Digital Operator Display
Input 1, H1-HC	Input 2, H2-HC			
OFF	OFF	OFF	Safely disabled, “Safe Torque Off”	Hbb (flashes)
ON	OFF	ON	Safely disabled, “Safe Torque Off”	HbbF (flashes)
OFF	ON	ON	Safely disabled, “Safe Torque Off”	HbbF (flashes)
ON	ON	ON	Baseblock, ready for operation	Normal display

Safe Disable Status Monitor

Note: Terminals H1, H2, DM+, and DM- on 600 V class models are designed to the functionality, but are not certified to EN61800-5-1, ISO13849 Cat. 3, IEC/EN61508 SIL2, Insulation coordination: class 1.

With the Safe Disable monitor output (terminals DM+ and DM-), the drive provides a safety status feedback signal. This signal should be read by the device that controls the Safe Disable inputs (PLC or a safety relay) in order to prohibit leaving the “Safe Torque Off” status in case the safety circuit malfunctions. Refer to the instruction manual of the safety device for details on this function.

Digital Operator Display

Note: Terminals H1, H2, DM+, and DM- on 600 V class models are designed to the functionality, but are not certified to EN61800-5-1, ISO13849 Cat. 3, IEC/EN61508 SIL2, Insulation coordination: class 1.

When both Safe Disable inputs are open, “Hbb” will flash in the digital operator display.

If one Safe Disable channel is on while the other is off, “HbbF” will flash in the display to indicate that there is a problem in the safety circuit or in the drive. This display should not appear under normal conditions if the Safe Disable circuit is utilized properly. *Refer to Alarm Codes, Causes, and Possible Solutions on page 366* to resolve possible errors.

This Page Intentionally Blank

Appendix: E

Quick Reference Sheet

This section provides tables to keep record of the drive specifications, motor specifications, and drive settings. Fill in the table data after commissioning the application and have them ready when contacting Yaskawa for technical assistance.

E.1	DRIVE AND MOTOR SPECIFICATIONS.....	680
E.2	BASIC PARAMETER SETTINGS.....	682
E.3	USER SETTING TABLE.....	684

E.1 Drive and Motor Specifications

◆ Drive Specifications

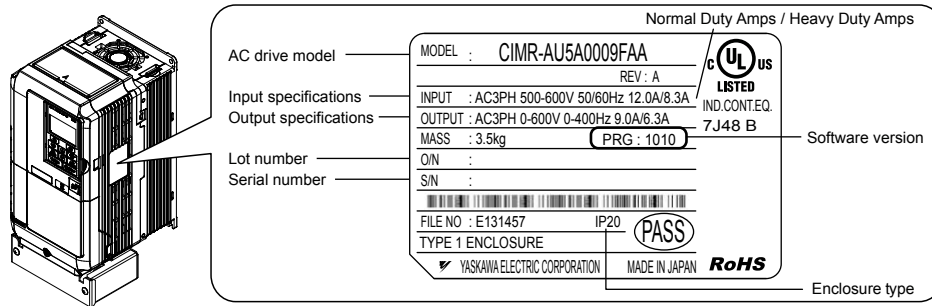

Items	Description
Model	CIMR-A
Serial Number	
Software Version (PRG)	
Options used	
Date of Usage	

◆ Motor Specifications

■ Induction Motor

Items	Description	Items	Description
Manufacturer		Motor Rated Current (T1-04)	A
Model		Motor Base Frequency (T1-05)	Hz
Motor Rated Power (T1-02)	HP	Number of Motor Poles (T1-06)	
Motor Rated Voltage (T1-03)	V	Motor Base Speed (T1-07)	r/min

Note: These values must be entered as part of the Auto-Tuning process.

■ Permanent Magnet Motor

Items	Description	Items	Description
Manufacturer		Induction Voltage Constant	mVs/rad
Model		Induction Voltage Constant	mV/(r/min)
PM Motor Rated Power (T2-04)	kW	PM Motor Rated Current (T2-06)	A
PM Motor Rated Voltage (T2-05)	V	PM Motor Base Frequency (T2-07)	Hz
q-Axis Inductance	mH	Number of PM Motor Poles (T2-08)	

x-Axis Inductance		mH	PM Motor Base Speed (T2-09)		r/min
--------------------------	--	----	------------------------------------	--	-------

Note: These values must be entered as part of the Auto-Tuning process.

■ **Motor Speed Encoder (if used)**

Items	Description	Items	Description
Manufacturer		Resolution	
Interface			

E.2 Basic Parameter Settings

Use the following tables to keep records of important parameters. Have this data available when contacting Yaskawa technical support.

◆ Basic Setup

Item	Setting Value	Memo
Control Mode	A1-02 =	
Normal/Heavy Duty Selection	C6-01 =	
Frequency Reference Source	b1-01 =	
Run Command Source	b1-02 =	

◆ V/f Pattern Setup

Item	Setting Value	Memo
V/f Pattern Selection	E1-03 =	
Max. Output Frequency	E1-04 =	
Max. Voltage	E1-05 =	
Base Frequency	E1-06 =	
Mid. Output Frequency	E1-07 =	
Mid. Output Frequency Volt.	E1-08 =	
Min. Output Frequency	E1-09 =	
Min. Output Frequency Volt.	E1-10 =	

◆ Motor Setup

Motor Type	Item	Setting Value	Memo
Induction	Motor Rated Current	E2-01 =	
	Motor Rated Slip	E2-02 =	
	Motor No-Load Current	E2-03 =	
	No. of Motor Poles	E2-04 =	
	Line-to-Line Resistance	E2-05 =	
	Motor Leakage Inductance	E2-06 =	
Permanent Magnet	Motor Code Selection	E5-01 =	
	Motor Rated Power	E5-02 =	
	Motor Rated Current	E5-03 =	
	No. of Motor Poles	E5-04 =	
	Motor Stator Resistance	E5-05 =	
	Motor d-Axis Inductance	E5-06 =	
	Motor q-Axis Inductance	E5-07 =	
	Induction Volt. Const. 1	E5-09 =	
	Encoder Z-pulse Offset	E5-11 =	
Induction Volt. Const. 2	E5-24 =		

◆ Multi-Function Digital Inputs

Terminal	Input Used	Setting Value and Function Name	Memo
S1		H1-01 =	
S2		H1-02 =	
S3		H1-03 =	
S4		H1-04 =	
S5		H1-05 =	
S6		H1-06 =	
S7		H1-07 =	
S8		H1-08 =	

◆ Pulse Train Input/Analog Inputs

Terminal	Input Used	Setting Value and Function Name	Memo
RP		H6-01 =	
A1		H3-02 =	
A2		H3-10 =	
A3		H3-06 =	

◆ Multi-Function Digital Outputs

Terminal	Output Used	Setting Value and Function Name	Memo
M1-M2		H2-01 =	
M3-M4		H2-02 =	
M5-M6		H2-03 =	

◆ Monitor Outputs

Terminal	Output Used	Setting Value and Function Name	Memo
FM		H4-01 =	
AM		H4-04 =	
MP		H6-06 =	

E.3 User Setting Table

Use the Verify Menu to determine which parameters have been changed from their original default settings

 below the parameter number indicates that the parameter setting can be changed during run.

Parameter names in **bold face type** are included in the Setup Group of parameters, which can be set by A1-06 = 0.

No.	Name	User Setting	No.	Name	User Setting
A1-00 	Language Selection		b3-10	Speed Search Detection Compensation Gain	
A1-01 	Access Level Selection		b3-12	Minimum Current Detection Level during Speed Search	
A1-02	Control Method Selection		b3-14	Bi-Directional Speed Search Selection	
A1-03	Initialize Parameters		b3-17	Speed Search Restart Current Level	
A1-04	Password		b3-18	Speed Search Restart Detection Time	
A1-05	Password Setting		b3-19	Number of Speed Search Restarts	
A1-06	Application Preset		b3-24	Speed Search Method Selection	
A1-07	DriveWorksEZ Function Selection		b3-25	Speed Search Wait Time	
A2-01 to A2-32	User Parameters, 1 to 32		b3-26	Direction Determining Level	
A2-33	User Parameter Automatic Selection		b3-27	Start Speed Search Select	
b1-01	Frequency Reference Selection 1		b4-01	Timer Function On-Delay Time	
b1-02	Run Command Selection 1		b4-02	Timer Function Off-Delay Time	
b1-03	Stopping Method Selection		b5-01	PID Function Setting	
b1-04	Reverse Operation Selection		b5-02 	Proportional Gain Setting (P)	
b1-05	Action Selection below Minimum Output Frequency		b5-03 	Integral Time Setting (I)	
b1-06	Digital Input Reading		b5-04 	Integral Limit Setting	
b1-07	LOCAL/REMOTE Run Selection		b5-05 	Derivative Time (D)	
b1-08	Run Command Selection while in Programming Mode		b5-06 	PID Output Limit	
b1-14	Phase Order Selection		b5-07 	PID Offset Adjustment	
b1-15	Frequency Reference Selection 2		b5-08 	PID Primary Delay Time Constant	
b1-16	Run Command Selection 2		b5-09	PID Output Level Selection	
b1-17	Run Command at Power Up		b5-10	PID Output Gain Setting	
b2-01	DC Injection Braking Start Frequency		b5-11	PID Output Reverse Selection	
b2-02	DC Injection Braking Current		b5-12	PID Feedback Loss Detection Selection	
b2-03	DC Injection Braking Time at Start		b5-13	PID Feedback Loss Detection Level	
b2-04	DC Injection Braking Time at Stop		b5-14	PID Feedback Loss Detection Time	
b2-08	Magnetic Flux Compensation Value		b5-15	PID Sleep Function Start Level	
b2-12	Short Circuit Brake Time at Start		b5-16	PID Sleep Delay Time	
b2-13	Short Circuit Brake Time at Stop		b5-17	PID Accel/Decel Time	
b2-18	Short Circuit Braking Current		b5-18	PID Setpoint Selection	
b3-01	Speed Search Selection at Start		b5-19 	PID Setpoint Value	
b3-02	Speed Search Deactivation Current		b5-20	PID Setpoint Scaling	
b3-03	Speed Search Deceleration Time		b5-34 	PID Output Lower Limit	
b3-04	V/f Gain during Speed Search		b5-35 	PID Input Limit	
b3-05	Speed Search Delay Time				
b3-06	Output Current 1 during Speed Search				
b3-07	Output Current 2 during Speed Search (Speed Estimation Type)				
b3-08	Current Control Gain during Speed Search (Speed Estimation Type)				

No.	Name	User Setting	No.	Name	User Setting
b5-36	PID Feedback High Detection Level		C2-04	S-Curve Characteristic at Decel End	
b5-37	PID Feedback High Detection Time		C3-01	Slip Compensation Gain	
b5-38	PID Setpoint User Display		C3-02	Slip Compensation Primary Delay Time	
b5-39	PID Setpoint Display Digits		C3-03	Slip Compensation Limit	
b5-40	Frequency Reference Monitor Content during PID		C3-04	Slip Compensation Selection during Regeneration	
b5-47	PID Output Reverse Selection 2		C3-05	Output Voltage Limit Operation Selection	
b6-01	Dwell Reference at Start		C3-21	Motor 2 Slip Compensation Gain	
b6-02	Dwell Time at Start		C3-22	Motor 2 Slip Compensation Primary Delay Time	
b6-03	Dwell Reference at Stop		C3-23	Motor 2 Slip Compensation Limit	
b6-04	Dwell Time at Stop		C3-24	Motor 2 Slip Compensation Selection during Regeneration	
b7-01	Droop Control Gain		C4-01	Torque Compensation Gain	
b7-02	Droop Control Delay Time		C4-02	Torque Compensation Primary Delay Time	
b7-03	Droop Control Limit Selection		C4-03	Torque Compensation at Forward Start	
b8-01	Energy Saving Control Selection		C4-04	Torque Compensation at Reverse Start	
b8-02	Energy Saving Gain		C4-05	Torque Compensation Time Constant	
b8-03	Energy Saving Control Filter Time Constant		C4-06	Torque Compensation Primary Delay Time 2	
b8-04	Energy Saving Coefficient Value		C4-07	Motor 2 Torque Compensation Gain	
b8-05	Power Detection Filter Time		C5-01	ASR Proportional Gain 1	
b8-06	Search Operation Voltage Limit		C5-02	ASR Integral Time 1	
b8-16	Energy Saving Parameter (Ki) for PM Motors		C5-03	ASR Proportional Gain 2	
b8-17	Energy Saving Parameter (Kt) for PM Motors		C5-04	ASR Integral Time 2	
b9-01	Zero Servo Gain		C5-05	ASR Limit	
b9-02	Zero Servo Completion Width		C5-06	ASR Primary Delay Time Constant	
C1-01	Acceleration Time 1		C5-07	ASR Gain Switching Frequency	
C1-02	Deceleration Time 1		C5-08	ASR Integral Limit	
C1-03	Acceleration Time 2		C5-12	Integral Operation during Accel/Decel	
C1-04	Deceleration Time 2		C5-17	Motor Inertia	
C1-05	Acceleration Time 3 (Motor 2 Accel Time 1)		C5-18	Load Inertia Ratio	
C1-06	Deceleration Time 3 (Motor 2 Decel Time 1)		C5-21	Motor 2 ASR Proportional Gain 1	
C1-07	Acceleration Time 4 (Motor 2 Accel Time 2)		C5-22	Motor 2 ASR Integral Time 1	
C1-08	Deceleration Time 4 (Motor 2 Decel Time 2)		C5-23	Motor 2 ASR Proportional Gain 2	
C1-09	Fast-Stop Time		C5-24	Motor 2 ASR Integral Time 2	
C1-10	Accel/Decel Time Setting Units		C5-25	Motor 2 ASR Limit	
C1-11	Accel/Decel Time Switching Frequency		C5-26	Motor 2 ASR Primary Delay Time Constant	
C2-01	S-Curve Characteristic at Accel Start				
C2-02	S-Curve Characteristic at Accel End				
C2-03	S-Curve Characteristic at Decel Start				

E.3 User Setting Table

No.	Name	User Setting	No.	Name	User Setting
C5-27	Motor 2 ASR Gain Switching Frequency		d3-02	Jump Frequency 2	
C5-28	Motor 2 ASR Integral Limit		d3-03	Jump Frequency 3	
C5-32	Integral Operation during Accel/Decel for Motor 2		d3-04	Jump Frequency Width	
C5-37	Motor 2 Inertia		d4-01	Frequency Reference Hold Function Selection	
C5-38	Motor 2 Load Inertia Ratio		d4-03	Frequency Reference Bias Step (Up/Down 2)	
C5-39	ASR Primary Delay Time Constant 2		d4-04	Frequency Reference Bias Accel/Decel (Up/Down 2)	
C6-01	Drive Duty Selection		d4-05	Frequency Reference Bias Operation Mode Selection (Up/Down 2)	
C6-02	Carrier Frequency Selection		d4-06	Frequency Reference Bias (Up/Down 2)	
C6-03	Carrier Frequency Upper Limit		d4-07	Analog Frequency Reference Fluctuation Limit (Up/Down 2)	
C6-04	Carrier Frequency Lower Limit		d4-08	Frequency Reference Bias Upper Limit (Up/Down 2)	
C6-05	Carrier Frequency Proportional Gain		d4-09	Frequency Reference Bias Lower Limit (Up/Down 2)	
C6-09	Carrier Frequency during Rotational Auto-Tuning		d4-10	Up/Down Frequency Reference Limit Selection	
d1-01	Frequency Reference 1		d5-01	Torque Control Selection	
d1-02	Frequency Reference 2		d5-02	Torque Reference Delay Time	
d1-03	Frequency Reference 3		d5-03	Speed Limit Selection	
d1-04	Frequency Reference 4		d5-04	Speed Limit	
d1-05	Frequency Reference 5		d5-05	Speed Limit Bias	
d1-06	Frequency Reference 6		d5-06	Speed/Torque Control Switchover Time	
d1-07	Frequency Reference 7		d5-08	Unidirectional Speed Limit Bias	
d1-08	Frequency Reference 8		d6-01	Field Weakening Level	
d1-09	Frequency Reference 9		d6-02	Field Weakening Frequency Limit	
d1-10	Frequency Reference 10		d6-03	Field Forcing Selection	
d1-11	Frequency Reference 11		d6-06	Field Forcing Limit	
d1-12	Frequency Reference 12		d7-01	Offset Frequency 1	
d1-13	Frequency Reference 13		d7-02	Offset Frequency 2	
d1-14	Frequency Reference 14		d7-03	Offset Frequency 3	
d1-15	Frequency Reference 15		E1-01	Input Voltage Setting	
d1-16	Frequency Reference 16		E1-03	V/f Pattern Selection	
d1-17	Jog Frequency Reference		E1-04	Maximum Output Frequency	
d2-01	Frequency Reference Upper Limit		E1-05	Maximum Voltage	
d2-02	Frequency Reference Lower Limit		E1-06	Base Frequency	
d2-03	Master Speed Reference Lower Limit		E1-07	Middle Output Frequency	
d3-01	Jump Frequency 1		E1-08	Middle Output Frequency Voltage	
			E1-09	Minimum Output Frequency	
			E1-10	Minimum Output Frequency Voltage	
			E1-11	Middle Output Frequency 2	
			E1-12	Middle Output Frequency Voltage 2	
			E1-13	Base Voltage	
			E2-01	Motor Rated Current	
			E2-02	Motor Rated Slip	
			E2-03	Motor No-Load Current	

No.	Name	User Setting	No.	Name	User Setting
E2-04	Number of Motor Poles		F1-11	Excessive Speed Deviation Detection Delay Time	
E2-05	Motor Line-to-Line Resistance		F1-12	PG 1 Gear Teeth 1	
E2-06	Motor Leakage Inductance		F1-13	PG 1 Gear Teeth 2	
E2-07	Motor Iron-Core Saturation Coefficient 1		F1-14	PG Open-Circuit Detection Time	
E2-08	Motor Iron-Core Saturation Coefficient 2		F1-18	dv3 Detection Selection	
E2-09	Motor Mechanical Loss		F1-19	dv4 Detection Selection	
E2-10	Motor Iron Loss for Torque Compensation		F1-20	PG Option Card Disconnect Detection 1	
E2-11	Motor Rated Power		F1-21	PG 1 Signal Selection	
E3-01	Motor 2 Control Mode Selection		F1-30	PG Option Card Port for Motor 2 Selection	
E3-04	Motor 2 Maximum Output Frequency		F1-31	PG 2 Pulses Per Revolution	
E3-05	Motor 2 Maximum Voltage		F1-32	PG 2 Rotation Selection	
E3-06	Motor 2 Base Frequency		F1-33	PG 2 Gear Teeth 1	
E3-07	Motor 2 Mid Output Frequency		F1-34	PG 2 Gear Teeth 2	
E3-08	Motor 2 Mid Output Frequency Voltage		F1-35	PG 2 Division Rate for PG Pulse Monitor	
E3-09	Motor 2 Minimum Output Frequency		F1-36	PG Option Card Disconnect Detection 2	
E3-10	Motor 2 Minimum Output Frequency Voltage		F1-37	PG2 Signal Selection	
E3-11	Motor 2 Mid Output Frequency 2		F2-01	Analog Input Option Card Operation Selection	
E3-12	Motor 2 Mid Output Frequency Voltage 2		F2-02	 Analog Input Option Card Gain	
E3-13	Motor 2 Base Voltage		F2-03	 Analog Input Option Card Bias	
E4-01	Motor 2 Rated Current		F3-01	Digital Input Option Card Input Selection	
E4-02	Motor 2 Rated Slip		F3-03	Digital Input Option DI-A3 Data Length Selection	
E4-03	Motor 2 Rated No-Load Current		F4-01	Terminal V1 Monitor Selection	
E4-04	Motor 2 Motor Poles		F4-02	 Terminal V1 Monitor Gain	
E4-05	Motor 2 Line-to-Line Resistance		F4-03	Terminal V2 Monitor Selection	
E4-06	Motor 2 Leakage Inductance		F4-04	 Terminal V2 Monitor Gain	
E4-07	Motor 2 Motor Iron-Core Saturation Coefficient 1		F4-05	 Terminal V1 Monitor Bias	
E4-08	Motor 2 Motor Iron-Core Saturation Coefficient 2		F4-06	 Terminal V2 Monitor Bias	
E4-09	Motor 2 Mechanical Loss		F4-07	Terminal V1 Signal Level	
E4-10	Motor 2 Iron Loss		F4-08	Terminal V2 Signal Level	
E4-11	Motor 2 Rated Power		F5-01	Terminal M1-M2 Output Selection	
E5-01	Motor Code Selection		F5-02	Terminal M3-M4 Output Selection	
E5-02	Motor Rated Power		F5-03	Terminal P1-PC Output Selection	
E5-03	Motor Rated Current		F5-04	Terminal P2-PC Output Selection	
E5-04	Number of Motor Poles		F5-05	Terminal P3-PC Output Selection	
E5-05	Motor Stator Resistance		F5-06	Terminal P4-PC Output Selection	
E5-06	Motor d-Axis Inductance		F5-07	Terminal P5-PC Output Selection	
E5-07	Motor q-Axis Inductance		F5-08	Terminal P6-PC Output Selection	
E5-09	Motor Induction Voltage Constant 1		F5-09	DO-A3 Output Mode Selection	
E5-11	Encoder Z-pulse Offset		F6-01	Communications Error Operation Selection	
E5-24	Motor Induction Voltage Constant 2		F6-02	External Fault from Comm. Option Detection Selection	
E5-25	Polarity Switch for Initial Polarity Estimation		F6-03	External Fault from Comm. Option Operation Selection	
F1-01	PG 1 Pulses Per Revolution		F6-04	bUS Error Detection Time	
F1-02	Operation Selection at PG Open Circuit (PGo)				
F1-03	Operation Selection at Overspeed (oS)				
F1-04	Operation Selection at Deviation				
F1-05	PG 1 Rotation Selection				
F1-06	PG 1 Division Rate for PG Pulse Monitor				
F1-08	Overspeed Detection Level				
F1-09	Overspeed Detection Delay Time				
F1-10	Excessive Speed Deviation Detection Level				

E.3 User Setting Table

No.	Name	User Setting	No.	Name	User Setting
F6-06	Torque Reference/Torque Limit Selection from Comm. Option		H2-03	Multi-Function Contact Output 3 (terminal M5-M6)	
F6-07	Multi-Step Speed Enable/Disable Selection when NefRef/ComRef is Selected		H2-06	Watt Hour Output Unit Selection	
F6-08	Reset Communication Parameters		H3-01	Terminal A1 Signal Level Selection	
F6-10	CC-Link Node Address		H3-02	Terminal A1 Function Selection	
F6-11	CC-Link Communications Speed		H3-03	Terminal A1 Gain Setting	
F6-14	CC-Link bUS Error Auto Reset		 H3-03	Terminal A1 Gain Setting	
F6-20	MECHATROLINK Station Address		 H3-04	Terminal A1 Bias Setting	
F6-21	MECHATROLINK Frame Size		H3-05	Terminal A3 Signal Level Selection	
F6-22	MECHATROLINK Link Speed		H3-06	Terminal A3 Function Selection	
F6-23	MECHATROLINK Monitor Selection (E)		H3-07	Terminal A3 Gain Setting	
F6-24	MECHATROLINK Monitor Selection (F)		 H3-07	Terminal A3 Gain Setting	
F6-25	Operation Selection at Watchdog Timer Error (E5)		H3-08	Terminal A3 Bias Setting	
F6-26	MECHATROLINK bUS Errors Detected		 H3-08	Terminal A3 Bias Setting	
F6-30	PROFIBUS-DP Node Address		H3-09	Terminal A2 Signal Level Selection	
F6-31	PROFIBUS-DP Clear Mode Selection		H3-10	Terminal A2 Function Selection	
F6-32	PROFIBUS-DP Data Format Selection		H3-11	Terminal A2 Gain Setting	
F6-35	CANopen Node ID Selection		 H3-11	Terminal A2 Gain Setting	
F6-36	CANopen Communication Speed		H3-12	Terminal A2 Bias Setting	
F6-50	DeviceNet MAC Address		 H3-12	Terminal A2 Bias Setting	
F6-51	DeviceNet Communication Speed		H3-13	Analog Input Filter Time Constant	
F6-52	DeviceNet PCA Setting		H3-14	Analog Input Terminal Enable Selection	
F6-53	DeviceNet PPA Setting		H4-01	Multi-Function Analog Output Terminal FM Monitor Selection	
F6-54	DeviceNet Idle Mode Fault Detection		H4-02	Multi-Function Analog Output Terminal FM Gain	
F6-55	DeviceNet Baud Rate Monitor		 H4-02	Multi-Function Analog Output Terminal FM Gain	
F6-56	DeviceNet Speed Scaling		H4-03	Multi-Function Analog Output Terminal FM Bias	
F6-57	DeviceNet Current Scaling		 H4-03	Multi-Function Analog Output Terminal FM Bias	
F6-58	DeviceNet Torque Scaling		H4-04	Multi-Function Analog Output Terminal AM Monitor Selection	
F6-59	DeviceNet Power Scaling		H4-05	Multi-Function Analog Output Terminal AM Gain	
F6-60	DeviceNet Voltage Scaling		 H4-05	Multi-Function Analog Output Terminal AM Gain	
F6-61	DeviceNet Time Scaling		H4-06	Multi-Function Analog Output Terminal AM Bias	
F6-62	DeviceNet Heartbeat Interval		 H4-06	Multi-Function Analog Output Terminal AM Bias	
F6-63	DeviceNet Network MAC ID		H4-07	Multi-Function Analog Output Terminal FM Signal Level Selection	
H1-01	Multi-Function Digital Input Terminal S1 Function Selection		H4-08	Multi-Function Analog Output Terminal AM Signal Level Selection	
H1-02	Multi-Function Digital Input Terminal S2 Function Selection		H5-01	Drive Node Address	
H1-03	Multi-Function Digital Input Terminal S3 Function Selection		H5-02	Communication Speed Selection	
H1-04	Multi-Function Digital Input Terminal S4 Function Selection		H5-03	Communication Parity Selection	
H1-05	Multi-Function Digital Input Terminal S5 Function Selection		H5-04	Stopping Method After Communication Error (CE)	
H1-06	Multi-Function Digital Input Terminal S6 Function Selection		H5-05	Communication Fault Detection Selection	
H1-07	Multi-Function Digital Input Terminal S7 Function Selection		H5-06	Drive Transmit Wait Time	
H1-08	Multi-Function Digital Input Terminal S8 Function Selection		H5-07	RTS Control Selection	
H2-01	Multi-Function Contact Output (terminal M1-M2)		H5-09	CE Detection Time	
H2-02	Multi-Function Contact Output 2 (terminal M3-M4)		H5-10	Unit Selection for MEMOBUS/Modbus Register 0025H	
			H5-11	Communications ENTER Function Selection	
			H5-12	Run Command Method Selection	
			H6-01	Pulse Train Input Terminal RP Function Selection	

No.	Name	User Setting	No.	Name	User Setting
H6-02 	Pulse Train Input Scaling		L3-34	Torque Limit Delay Time	
H6-03 	Pulse Train Input Gain		L4-01	Speed Agreement Detection Level	
H6-04 	Pulse Train Input Bias		L4-02	Speed Agreement Detection Width	
H6-05 	Pulse Train Input Filter Time		L4-03	Speed Agreement Detection Level (+/-)	
H6-06 	Pulse Train Monitor Selection		L4-04	Speed Agreement Detection Width (+/-)	
H6-07 	Pulse Train Monitor Scaling		L4-05	Frequency Reference Loss Detection Selection	
H6-08	Pulse Train Input Minimum Frequency		L4-06	Frequency Reference at Reference Loss	
L1-01	Motor Overload Protection Selection		L4-07	Speed Agreement Detection Selection	
L1-02	Motor Overload Protection Time		L5-01	Number of Auto Restart Attempts	
L1-03	Motor Overheat Alarm Operation Selection (PTC input)		L5-02	Auto Restart Fault Output Operation Selection	
L1-04	Motor Overheat Fault Operation Selection (PTC input)		L5-04	Fault Reset Interval Time	
L1-05	Motor Temperature Input Filter Time (PTC input)		L5-05	Fault Reset Operation Selection	
L1-13	Continuous Electrothermal Operation Selection		L6-01	Torque Detection Selection 1	
L2-01	Momentary Power Loss Operation Selection		L6-02	Torque Detection Level 1	
L2-02	Momentary Power Loss Ride-Thru Time		L6-03	Torque Detection Time 1	
L2-03	Momentary Power Loss Minimum Baseblock Time		L6-04	Torque Detection Selection 2	
L2-04	Momentary Power Loss Voltage Recovery Ramp Time		L6-05	Torque Detection Level 2	
L2-05	Undervoltage Detection Level (Uv1)		L6-06	Torque Detection Time 2	
L2-06	KEB Deceleration Time		L6-08	Mechanical Weakening Detection Operation	
L2-07	KEB Acceleration Time		L6-09	Mechanical Weakening Detection Speed Level	
L2-08	Frequency Gain at KEB Start		L6-10	Mechanical Weakening Detection Time	
L2-10	KEB Detection Time (Minimum KEB Time)		L6-11	Mechanical Weakening Detection Start Time	
L2-11	DC Bus Voltage Setpoint during KEB		L7-01	Forward Torque Limit	
L2-29	KEB Method Selection		L7-02	Reverse Torque Limit	
L3-01	Stall Prevention Selection during Acceleration		L7-03	Forward Regenerative Torque Limit	
L3-02	Stall Prevention Level during Acceleration		L7-04	Reverse Regenerative Torque Limit	
L3-03	Stall Prevention Limit during Acceleration		L7-06	Torque Limit Integral Time Constant	
L3-04 	Stall Prevention Selection during Deceleration		L7-07	Torque Limit Control Method Selection during Accel/Decel	
L3-05	Stall Prevention Selection during Run		L8-01	Internal Dynamic Braking Resistor Protection Selection (ERF type)	
L3-06	Stall Prevention Level during Run		L8-02	Overheat Alarm Level	
L3-11	Overvoltage Suppression Function Selection		L8-03	Overheat Pre-Alarm Operation Selection	
L3-17	Target DC Bus Voltage for Overvoltage Suppression and Stall Prevention		L8-05	Input Phase Loss Protection Selection	
L3-20	DC Bus Voltage Adjustment Gain		L8-07	Output Phase Loss Protection	
L3-21	Accel/Decel Rate Calculation Gain		L8-09	Output Ground Fault Detection Selection	
L3-22	Deceleration Time at Stall Prevention during Acceleration		L8-10	Heatsink Cooling Fan Operation Selection	
L3-23	Automatic Reduction Selection for Stall Prevention during Run		L8-11	Heatsink Cooling Fan Off Delay Time	
L3-24	Motor Acceleration Time for Inertia Calculations		L8-12	Ambient Temperature Setting	
L3-25	Load Inertia Ratio		L8-15	oL2 Characteristics Selection at Low Speeds	
L3-26	Additional DC Bus Capacitors		L8-18	Software Current Limit Selection	
L3-27	Stall Prevention Detection Time		L8-19	Frequency Reduction Rate during Overheat Pre-Alarm	
			L8-27	Overcurrent Detection Gain	
			L8-29	Current Unbalance Detection (LF2)	
			L8-32	Main Contactor and Cooling Fan Power Supply Failure Selection	
			L8-35	Installation Method Selection	
			L8-38	Carrier Frequency Reduction Selection	
			L8-40	Carrier Frequency Reduction Off-Delay Time	
			L8-41	High Current Alarm Selection	

E.3 User Setting Table

No.	Name	User Setting	No.	Name	User Setting
L8-55	Internal Braking Transistor Protection		o1-11	User-Set Display Units Decimal Display	
L8-78	Power Unit Output Phase Loss Protection		o2-01	LO/RE Key Function Selection	
L8-93	LSO Detection Time at Low Speed		o2-02	STOP Key Function Selection	
L8-94	LSO Detection Level at Low Speed		o2-03	User Parameter Default Value	
L8-95	Average LSO Frequency at Low Speed		o2-04	Drive Model Selection	
n1-01	Hunting Prevention Selection		o2-05	Frequency Reference Setting Method Selection	
n1-02	Hunting Prevention Gain Setting		o2-06	Operation Selection when Digital Operator is Disconnected	
n1-03	Hunting Prevention Time Constant		o2-07	Motor Direction at Power Up when Using Operator	
n1-05	Hunting Prevention Gain while in Reverse		o3-01	Copy Function Selection	
n2-01	Speed Feedback Detection Control (AFR) Gain		o3-02	Copy Allowed Selection	
n2-02	Speed Feedback Detection Control (AFR) Time Constant 1		o4-01	Cumulative Operation Time Setting	
n2-03	Speed Feedback Detection Control (AFR) Time Constant 2		o4-02	Cumulative Operation Time Selection	
n3-01	High-Slip Braking Deceleration Frequency Width		o4-03	Cooling Fan Maintenance Operation Time Setting	
n3-02	High-Slip Braking Current Limit		o4-05	Capacitor Maintenance Setting	
n3-03	High-Slip Braking Dwell Time at Stop		o4-07	DC Bus Pre-charge Relay Maintenance Setting	
n3-04	High-Slip Braking Overload Time		o4-09	IGBT Maintenance Setting	
n3-13	Overexcitation Deceleration Gain		o4-11	U2, U3 Initialize Selection	
n3-14	High Frequency Injection during Overexcitation Deceleration		o4-12	kWh Monitor Initialization	
n3-21	High-Slip Suppression Current Level		o4-13	Number of Run Commands Counter Initialization	
n3-23	Overexcitation Operation Selection		q1-01 to q6-07	DriveWorksEZ Parameters	
n5-01	Feed Forward Control Selection		r1-01 to r1-40	DWEZ Connection Parameter 1 to 20 (upper/lower)	
n5-02	Motor Acceleration Time		T1-00	Motor 1/Motor 2 Selection	
n5-03	Feed Forward Control Gain		T1-01	Auto-Tuning Mode Selection	
n6-01	Online Tuning Selection		T1-02	Motor Rated Power	
n6-05	Online Tuning Gain		T1-03	Motor Rated Voltage	
n8-01	Initial Rotor Position Estimation Current		T1-04	Motor Rated Current	
n8-02	Pole Attraction Current		T1-05	Motor Base Frequency	
n8-35	Initial Rotor Position Detection Selection		T1-06	Number of Motor Poles	
n8-45	Speed Feedback Detection Control Gain		T1-07	Motor Base Speed	
n8-47	Pull-In Current Compensation Time Constant		T1-08	PG Number of Pulses Per Revolution	
n8-48	Pull-In Current		T1-09	Motor No-Load Current (Stationary Auto-Tuning)	
n8-49	d-Axis Current for High Efficiency Control		T1-10	Motor Rated Slip (Stationary Auto-Tuning)	
n8-51	Acceleration/Deceleration Pull-In Current		T1-11	Motor Iron Loss	
n8-54	Voltage Error Compensation Time Constant		T2-01	PM Motor Auto-Tuning Mode Selection	
n8-55	Load Inertia		T2-02	PM Motor Code Selection	
n8-57	High Frequency Injection		T2-03	PM Motor Type	
n8-62	Output Voltage Limit		T2-04	PM Motor Rated Power	
n8-65	Speed Feedback Detection Control Gain during ov Suppression		T2-05	PM Motor Rated Voltage	
n8-69	Speed Calculation Gain		T2-06	PM Motor Rated Current	
n8-84	Polarity Judge Current		T2-07	PM Motor Base Frequency	
o1-01	 Drive Mode Unit Monitor Selection		T2-08	Number of PM Motor Poles	
o1-02	 User Monitor Selection After Power Up		T2-09	PM Motor Base Speed	
o1-03	Digital Operator Display Selection		T2-10	PM Motor Stator Resistance	
o1-04	V/f Pattern Display Unit		T2-11	PM Motor d-Axis Inductance	
o1-10	User-Set Display Units Maximum Value		T2-12	PM Motor q-Axis Inductance	
			T2-13	Induced Voltage Constant Unit Selection	
			T2-14	PM Motor Induced Voltage Constant	
			T2-15	Pull-In Current Level for PM Motor Tuning	

E.3 User Setting Table

No.	Name	User Setting
T2-16	PG Number of Pulses Per Revolution for PM Motor Tuning	
T2-17	Encoder Z Pulse Offset	
T3-01	Test Signal Frequency	

No.	Name	User Setting
T3-02	Test Signal Amplitude	
T3-03	Motor Inertia	
T3-04	System Response Frequency	

<1> Not available in models 4A0930 and 4A1200.

<2> Parameter setting cannot be changed while the drive is operating the motor in models 4A0930 and 4A1200.

This Page Intentionally Blank

Analog Inputs / Pulse Train Input	99	Braking Transistor	472
Analog Input Terminal Enable Selection	271	Braking Transistor Overload Fault	347, 366
Analog Monitor Card Settings	240	Broadcast Messages	637
AO-A3	437	bUS	347, 366
AO-A3 Settings	240	bUS Error Detection Time	243
Application Presets	132	C	
Application Selection	3	C1-01	123
ASR	200	C2-01 through C2-04	341
ASR Gain Auto-Tuning	137	C3-01	336, 337
ASR Gain Switching Frequency	202	C3-02	337
ASR Integral Limit	203	C4-01	336
ASR Integral Time	202	C4-02	336, 337
ASR Limit	203	C4-06	337
ASR Primary Delay Time Constant	203	C6-01	336
ASR Proportional Gain	202	C6-02	110, 336, 337, 393
ASR Response Frequency	147	C6-05	393
Attachment for External Heatsink	438, 459	Cable Length Between Drive and Motor	96
Automatic Reduction Selection for Stall Prevention during Run ...	297, 544	CALL	366
Automatic Speed Regulator	200	Cannot Change Parameter Settings	388
Auto Restart Fault Output Operation Selection	301	Cannot Reset	367
Auto Restart Operation Selection	545	CANopen Communication Speed	244
Auto-Tuning	3, 138, 141	CANopen Node ID Selection	244
Auto-Tuning Codes	379	CANopen Parameters	242, 244
Auto-Tuning Errors	346	Capacitor Maintenance	566
Auto-Tuning Fault Codes	139	Capacitor Maintenance Setting	328, 555
Auto-Tuning Fault Detection	227	Capacitor Maintenance Time	370
Auto-Tuning Fault Solutions	379	Carrier Frequency	205, 463, 464, 465, 466, 467, 468, 469, 470, 471
Auto-Tuning for Induction Motors	135	Carrier Frequency and Current Derating	479, 481
Auto-Tuning for Permanent Magnet Motors	136	Carrier Frequency Derating	32
Auto-Tuning Input Data	136, 137, 138	Carrier Frequency during Rotational Auto-Tuning	207
Auto-Tuning Interruption and Fault Codes	139	Carrier Frequency Lower Limit	206
Auto-Tuning Mode Selection	142, 558	Carrier Frequency Proportional Gain	206
B		Carrier Frequency Reduction	548
B1	87	Carrier Frequency Reduction Off-Delay Time	311
b1-01	389	Carrier Frequency Reduction Selection	311
b1-02	389	Carrier Frequency Selection	96, 336, 337
b1-04	390	Carrier Frequency Setting Error	378
B2	87	Carrier Frequency Upper Limit	206
b2-02	394	CC-Link bUS Error Auto Reset	243
b2-04	394	CC-Link Communication Speed	243
b5-09	394	CC-Link Node Address	243
b6-01 through b6-04	341	CC-Link Parameters	242, 243
Backing Up Parameter Values	151	CE	347, 367
Baseblock	366	CE Detection Time	617
Base Frequency	226	CE Low Voltage Directive Compliance	648
Base Voltage	227	CE mark	648
Basic Auto-Tuning Preparations	138	CF	347
Basic Start-up and Motor Tuning	127	Changing Parameter Settings or Values	121
bb	366	Circulation Fan	48, 49
Bi-Directional Speed Search Selection	177	Closed-Loop Crimp Terminal Size	89
boL	347, 366	Closed Loop Vector control	32
Braking circuit protective cover	97	Closed Loop Vector Control for PM Motors	32
Braking Resistor	437, 449	Coast to stop	165
Braking Resistor Fault	361	Coast to Stop with Timer	166
Braking Resistor Overheat	362	Comm. option card connection error (CN5-A)	355
Braking Resistor Overheat Protection	473	Command Messages from Master to Drive	620
Braking Resistor Overload Protection	450	Communication Error	384
Braking Torque	472	Communication Fault Detection Selection	616
		Communication Option Card	242

Communication Option Card Reference	568	CPF08	348
Communication Option Station Number Setting Error (CC-Link, CANopen, MECHATROLINK-II)	366	CPF11 to CPF14	348
Communication Parity Selection	616	CPF16 to CPF19	348
Communications Enter Function Selection	618	CPF20	348
Communications Error Operation Selection	242	CPF21	348
Communication Speed Selection	616	CPF22	349
Communications Timing	620	CPF23	349
Comparing Parameter Settings	385	CPF24	349
Component Names	42	CPF25	349
Compressor Application	134	CPF26 to CPF35	349
Conduit bracket	42, 44	CPF40 to CPF45	349
Conduit Bracket Dimensions for IP20/NEMA Type 1	63	CPyE	384
Conduit bracket front cover	42	CRC-16	621
Connected Machinery Vibrates When Motor Rotates	393	CRC-16 Checksum Calculation Example	622
Connecting a DC Link Choke	453	CrST	367
Connecting an AC Reactor	453	CSEr	384
Connecting a Noise Filter	454	Cumulative Operation Time	566
Connecting a Suppression Diode	99	Cumulative Operation Time at 5th Most Recent Fault	566
Connecting a Surge Absorber	453	Cumulative Operation Time at Most Recent Fault	566
Connecting Braking Units in Parallel	451	Cumulative Operation Time at Previous Fault	565
Connecting Peripheral Devices	439	Cumulative Operation Time Selection	328, 555
Connecting to a PC (USB)	108	Cumulative Operation Time Setting	328, 555
Connection of a Motor PTC	282	Current Alarm	369
Continuous Electrothermal Operation Selection	284, 541	Current Detection Error	381
Control Board Connection Error	348, 349	Current Detection Speed Search	173
Control Circuit Error	348, 349	Current Fault	564
Control Circuit Input Terminals	98	Current Unbalance	364
Control Circuit Output Terminals	99	Current Unbalance Detection (LF2)	310, 548
Control Circuit Terminal Block Functions	98	Cyclic Redundancy Check	621
Control Fault	347		
Control Method Selection	157	D	
Control Method Selection Error	376	d2-01	394
Control Mode	157, 562	d3-01	393
Control Mode Dependent Parameter Default Values	571	d3-01 through d3-04	341
Control Mode Mismatch	384	d3-04	393
Control Modes and their Features	32	Daily Inspection	400
Control Mode Selection	32	d-Axis ACR Output	569
Control Power Supply Voltage Fault	364	d-Axis Current for High Efficiency Control	320
Conveyor Application	133	DC bus circuit protective cover	97
Cooling Fan	42, 43, 45, 46, 47, 48, 49	DC Bus Overvoltage	372
Cooling fan	44	DC Bus Pre-Charge Relay Maintenance Setting	329
Cooling Fan Maintenance	566	DC Bus Undervoltage	364
Cooling Fan Maintenance Setting (Operation Time)	555	DC Bus Voltage	562
Cooling Fan Maintenance Time	370	DC Bus Voltage Adjustment Gain	298
Cooling Fan Operation Time	566	DC Bus Voltage at Previous Fault	564
Cooling Fan Operation Time Setting	328	DC Bus Voltage Setpoint during KEB	293
Cooling Fan Replacement	357	DC Injection Braking at Stop	394
CoPy	384	DC Injection Braking Current	171, 394
Copy Allowed Selection	328	DC Injection Braking Input Timing Diagram	255
Copy Function	152	DC Injection Braking Start Frequency	164
Copy Function Errors	342	DC Injection Braking Time at Start	165
Copy Function Selection	327	DC Injection Braking Time at Stop	171
Copy Unit Error	384	DC Injection Braking to Stop	165
CopyUnitManager	152	DC link choke	437
CPEr	384	DC Link Chokes for EN 61000-3-2 Compliance	651
CPF02	348	D Control	179
CPF03	348	Deceleration Rate Calculation Gain	544
CPF06	348	Deceleration Time	193
CPF07	348	Deceleration Time at Stall Prevention during Acceleration	294, 544
		Defaults by Drive Model Selection (o2-04) and ND/HD (C6-01)	326

Delay Timers	178	Drive Model Selection	326
Derivative Time (D)	182	Drive Mode Unit Monitor Selection	324, 554
Desired DC Bus Voltage during KEB	543	Drive Operation Status at Previous Fault	565
dEv	349, 367	Drive Overheat Warning	370
DeviceNet Baud Rate Monitor	245	Drive Overload	358
DeviceNet Communication Speed	245	Drive Ready	109
DeviceNet Heartbeat Interval	246	Drive Replacement	432
DeviceNet Idle Mode Fault Detection	245	Drive Slave Address	616
DeviceNet MAC Address	245	Drive Specifications	472
DeviceNet Network MAC ID	246	Drive Status	563
DeviceNet Parameters	242, 245	Drive Transmit Wait Time	617
DeviceNet PCA Setting	245	Drive Unit Signal Fault	349
DeviceNet PPA Setting	245	Drive Watt Loss Data	474
DeviceNet Scaling Factors	246	DriveWizard 2010	438
dFPS	384	DriveWizard Plus	152
DI-A3	437	DriveWorksEZ	438
DI-A3 Settings	239	DriveWorksEZ Connection Parameters	330
Diagnosing and Resetting Faults	353	DriveWorksEZ Custom Monitor 1 to 10	570
Digital Input Card Settings	239	DriveWorksEZ Fault	351
Digital Input Option Card Input Selection	239	DriveWorksEZ Function Selection	161
Digital Input Option DI-A3 Data Length Selection	240	DriveWorksEZ Monitors	332
Digital Input Reading	168	DriveWorksEZ Parameters	330
Digital Operator	42, 43, 44, 45, 46, 47, 48, 49, 42	Droop Control Delay Time	190
Digital Operator Dimensions	58	Droop Control Gain	189
Digital Operator Display Selection	324, 554	During Frequency Output Time Chart	266
Digital Operator Installation Methods and Required Tools	58	During Run Time Chart	259
Digital Operator Keypad Functions	325	dv1	349
Digital Operator Menu and Screen Structure	119	dv2	350
Digital Operator Remote Installation	58	dv3	350
digital operator remote usage	57	dv3 Detection Selection	238
Digital Output Card Settings	241	dv4	350
Digital Output Option Card Terminal Function Selection	241	dv4 Detection Selection	238
Dimensions for IP00/Open Type Enclosure: 200 V Class	66	dv7	350
Dimensions for IP00/Open Type Enclosure: 400 V Class	66	dWAL	351
Dimensions for IP00/Open Type Enclosure: 600V Class	66	Dwell Function	188, 341
Dimensions for IP20/NEMA Type 1 Enclosure: 200 V Class	61	Dwell Reference at Start	189
Dimensions for IP20/NEMA Type 1 Enclosure: 400 V Class	62	Dwell Reference at Stop	189
Dimensions for IP20/NEMA Type 1 Enclosure: 600 V Class	62	Dwell Time at Start	189
DIP Switch S1	50	Dwell Time at Stop	189
DIP Switch S1 Settings	106	DWEZ Version Control Monitor 1 to 3	570
DIP Switch S2	50	dWFL	351
DIP Switch S4 Settings	106	Dynamic Braking Options	449
DM-	99	Dynamic Braking Transistor	362
DM+	99		
dnE	368	E	
DO-A3	437	E (G)	99
DO-A3 Output Mode Selection	241	E1-03	391
DO-A3 Settings	241	E1-04	391, 394
Down Arrow Key	115	E1-08	336, 337
Drive/kVA Selection	554	E1-09	389
Drive Capacity Setting Fault	375	E1-10	336, 337
Drive Cooling Fans	402	E2-01	336, 671
Drive Cover	43, 44, 45, 46, 47, 48, 49	E2-02	336
Drive Derating Data	54	E2-03	336, 380
Drive Disabled	368	E3-01 (Motor 2 Control Mode) Dependent Parameters	574
Drive Does Not Allow Selection of Rotational Auto-Tuning	391	E5	351
Drive Duty Mode Selection	3	EEPROM Memory Data Error	348
Drive Mode	120, 121	EEPROM Write Error	351
Drive Model Mismatch	384	EF	368
Drive Models and Types	60	EF0	351, 368

EF1	351, 368	Error Writing Data	384
EF2	351, 368	European Standards	3
EF3	351, 368	Excessive Motor Oscillation and Erratic Rotation	392
EF4	351, 368	Excessive PID Feedback	352, 368
EF5	351, 368	Excessive Speed Deviation Detection Delay Time	237
EF6	351, 368	Excessive Speed Deviation Detection Level	237
EF7	351, 368	Excessive V/f Setting	379
EF8	351, 368	Exhaust Fan Application	133
Electromotive Force Parameter Tuning	136	Exterior and Mounting Dimensions	60
EMC Filter and Drive Installation for CE Compliance	652	External Digital Operator Connection Fault	360
EMC Filter Installation	91	External Fault	351, 368
EMC Filters	650	External Fault from Comm. Option Detection Selection	242
EMC Guidelines	648	External Fault from Comm. Option Operation Selection	242
EMC Guidelines Compliance	650	External Interlock	109
EN61800-3 Filters	653	F	
Enclosure Types	39	FAn	352
Encoder Z-Pulse Offset	146, 235	FAn Alarm Location Monitor	568
End	384	Fan Bracket	45, 46, 47
End1	379	Fan bracket	44
End2	379	Fan Cover	42, 43
End3	379	Fan Finger Guard	42, 43
End4	379	Fan Guard	45, 46, 47, 48, 49
End5	379	Fast Stop Sequence	252
End6	379	Fast Stop Time	194
End7	380	Fault Causes and Solutions	347
Energy Saving	190	Fault Detection	347
Energy Saving Coefficient Value	191	Fault Displays	347
Energy Saving Control Filter Time Constant	191	Fault History	331, 386
Energy Saving Control Selection	190	Fault Relay Output	99
Energy Saving Gain	190	Fault Reset Interval Time	302, 545
Energy Savings Constants Error	378	Fault Reset Methods	342
Enter Command	618	Fault Reset Operation Selection	302, 545
Enter command necessary	618	Fault Restart	265
Enter command not necessary	618	Faults	342, 343
Enter Command Settings when Upgrading the Drive	641	Fault Trace	331, 386
Enter Command Types	641	FbH	352, 368
Enter Data from the Motor Nameplate	140	FbL	352, 369
ENTER Key	115	Feed Forward Control	317, 341
Er-01	380	Feed Forward Control Diagram	317
Er-02	380	Feed Forward Control Gain	318
Er-03	380	Feed Forward Control Selection	317
Er-04	380	Ferrule Dimensions	101
Er-05	380	Ferrule Terminal Types and Sizes	101
Er-08	381	Ferrule-Type Wire Terminals	101
Er-09	381	Field Forcing	221
Er-10	381	Field Forcing Limit	222
Er-11	381	Field Forcing Selection	222
Er-12	381	Field Weakening	221
Er-13	382	Field Weakening Frequency Limit	221
Er-14	382	Field Weakening Level	221
Er-15	382	Fine-Tuning Advanced Open Loop Vector Control for PM Motors	340
Er-16	382	Fine-Tuning Closed Loop Vector Control	338
Er-17	382	Fine-Tuning Closed Loop Vector Control for PM Motors	340
Er-18	382	Fine-Tuning Open Loop Vector Control	337
Er-19	382	Fine-Tuning Open Loop Vector Control for PM Motors	339
Er-20	382	Fine-Tuning V/f Control and V/f Control with PG	336
Er-21	383	FJOG/RJOG Operation	251
Err	351	FM	99
Error Reading Data	385	Forward/Reverse Run Command Input Error	368
Errors and Displays When Using the Copy Function	346		

Forward Regenerative Torque Limit.....	305, 547	H3-13.....	341, 393
Forward Torque Limit.....	305, 547	H3 Multi-Function Analog Input Settings.....	537
Frequency Accuracy (Temperature Fluctuation).....	472	Hbb.....	369
Frequency Control Range.....	472	HbbF.....	369
Frequency Detection 1 Time Chart.....	261	HC.....	98
Frequency Detection 2 Time Chart.....	261	HCA.....	369
Frequency Detection 3 Example with a Positive L3-04 Value.....	264	HD.....	205
Frequency Detection 4 Example with Positive L3-04 Value.....	264	HD and ND.....	462
Frequency Gain at KEB Start.....	292	Heatsink.....	42, 43, 44, 45, 46, 47, 48, 49
Frequency Reduction Rate during Overheat Pre-Alarm.....	307, 548	Heatsink Cooling Fan Off-Delay Time.....	309
Frequency Reference.....	208, 562	Heatsink Cooling Fan Operation Delay Time.....	548
Frequency Reference at Previous Fault.....	564	Heatsink Cooling Fan Operation Selection.....	308, 548
Frequency Reference at Reference Loss.....	300, 545	Heatsink Overheat.....	357, 370
Frequency Reference Bias.....	214	Heatsink Temperature.....	566
Frequency Reference Bias (Up/Down 2).....	570	Heavy Duty.....	205
Frequency Reference Bias Accel/Decel.....	215	Heavy Duty Ratings.....	205
Frequency Reference Bias Lower Limit.....	214	High Current Alarm Selection.....	311
Frequency Reference Bias Operation Mode Selection.....	215	High Frequency Injection.....	157
Frequency Reference Bias Step.....	214	High Frequency Injection during Overexcitation Deceleration.....	316
Frequency Reference Bias Upper Limit.....	214	High Performance Operation Using OLV or CLV.....	129
Frequency Reference from MEMOBUS/Modbus Comm.....	567	High Slip Braking.....	314
Frequency Reference Hold.....	212	High Slip Braking Current Limit.....	315
Frequency Reference Hold Function Selection.....	212	High-Slip Braking Current Limit.....	550
Frequency Reference Loss Detection Selection.....	262, 545	High Slip Braking Deceleration Frequency Width.....	314
Frequency Reference Lower Limit.....	210	High-Slip Braking Deceleration Frequency Width.....	550
Frequency Reference Monitor Content During PID.....	187	High Slip Braking Dwell Time at Stop.....	315
Frequency Reference Selection.....	495	High-Slip Braking Dwell Time at Stop.....	551
Frequency Reference Selection 1.....	162, 389	High-slip Braking oL.....	359
Frequency Reference Selection 2.....	169	High Slip Braking Overload Time.....	315
Frequency Reference Setting / Decimal Display.....	554	High-Slip Braking Overload Time.....	551
Frequency Reference Setting and User-Set Display.....	554	High Slip Suppression Current Level.....	316
Frequency Reference Setting Hierarchy.....	208	High-Slip Suppression Current Level.....	551
Frequency Reference Setting Method Selection.....	326, 555	HSB.....	256
Frequency Reference Source Selection.....	567	Humidity.....	54
Frequency Reference Upper Limit.....	210	Hunting Prevention.....	313
Frequency Setting Resolution.....	472	Hunting Prevention Gain.....	336
Frequency Setting Signal.....	472	Hunting Prevention Gain Setting.....	313, 550
Front Cover.....	42, 43, 44, 45, 46, 47, 48, 49	Hunting Prevention Gain while in Reverse.....	313, 550
Front Cover Screw.....	43, 45, 46, 47, 48, 49	Hunting Prevention Selection.....	313, 550
Function Code.....	621	Hunting Prevention Time Constant.....	313, 550
Functions for Terminals S1 to S8.....	247	HVAC Fan Application.....	134
Fuse.....	455	Hybrid IC Failure.....	349
Fuse Selection.....	455, 457, 648, 667, 669		
G		I	
Gate Drive Board Undervoltage.....	365	I/O Connections.....	100
General Safety Information.....	20	I Control.....	179
GF.....	352	iFEr.....	384
Ground Fault.....	352	IG.....	100
Ground Terminal.....	50	IGBT Maintenance.....	566
Ground Wiring.....	96	IGBT Maintenance Setting.....	329, 555
H		IGBT Maintenance Time (50%).....	370
H1.....	98	IGBT Maintenance Time (90%).....	373
H1 Multi-Function Digital Input Selections.....	528	IGBT Short Circuit or Ground Fault.....	362
H2.....	98	Induced Noise.....	454
H3-02.....	392, 393, 394	Induced Voltage Constant Unit Selection.....	145
H3-09.....	106	Induction Voltage Error.....	382
H3-10.....	393, 394	Inertia Detection Error.....	382
H3-11.....	394	Inertia Tuning.....	137
		Inertia Tuning Frequency Reference.....	146
		Inertia Tuning Reference Amplitude.....	146

Initialization	156	KEB Method Selection	293
Initialization Required	376	KEB Operation Using a KEB Input	288
Initialize Parameters	151, 157	KEB Operation Using L2-02, Without KEB Input	288
Initial Operation	126	KEB Operation Using L2-02 and KEB Input	289
Initial Rotor Position Detection Selection	319	KEB Operation Using L2-10, Without KEB Input	289
Initial Rotor Position Estimation Current	319	KEB Operation Using L2-10 and KEB Input	290
Input Current	463, 464, 465, 466, 467, 468, 469, 470, 471	KEB Operation Wiring Example	290
Input Fuses	455, 457, 648, 667, 669	KEB Ride-Thru End Detection	288
Input Phase Loss	361	KEB Ride-Thru Function	255
Input Phase Loss Protection Selection	308, 548	KEB Ride-Thru Start	287
Input Power	463, 464, 465, 466, 467, 468, 469, 470, 471	KEB Start Output Frequency Reduction	542
Input Pulse Monitor	564	Keys and Displays on the Digital Operator	115
Input Terminals	125	kWh	567
Input Terminal Status	562	kWh, Lower 4 Digits	567
Input Terminal Status at Previous Fault	565	kWh, Upper 5 Digits	567
Input Voltage Setting	223	kWh Monitor Initialization	329
Inrush Prevention Circuit Fault	364	kWh Monitor Initial Value Selection	556
Inrush Prevention Relay Maintenance Setting	555	L	
Inspection	400, 401	L3-01 through L3-06	341
Installation Area	54	L3-02	392, 394
Installation Environment	54	L3-04	392
Installation Method Selection	55	L3-06	392
Installation Orientation	54	L3-11	341
Installation Orientation and Spacing	54	L3-34: Torque Limit Delay Time	299
Installation Spacing	55	L7-01 through L7-04	341, 393
Installing a Braking Resistor\ : ERF type	449	L7-06	341
Installing a Braking Resistor Unit\ : LKEB type	449	L7-07	341
Installing a Braking Unit\ : CDBR Type	450	L8-12	486
Installing a GFCI	452	L8-35	486
Installing a Magnetic Contactor	24	L8-38	394
Installing a Molded Case Circuit Breaker (MCCB)	24	Language Selection	156
Installing a Motor Thermal Overload (oL) Relay on the Drive Output	459	LCD Display	116
Installing Other Types of Braking Resistors	450	Leakage Inductance Alarm	379
Installing Peripheral Devices	449	Leakage Inductance Error	382
Installing the Cooling Fan	410	LED Check	567
Integral Limit Setting	182	LED Operator	438
Integral Operation during Accel/Decel	203	LF	353
Integral Operation during Accel/Decel for Motor 2	204	LF2	353
Integral Time Setting (I)	182	LF3	353
Interlock Circuit Example	109	Line-to-Line Motor Resistance Online Tuning	552
Internal Dynamic Braking Resistor Protection Selection (ERF type)	306, 547	Line-to-Line Resistance Error	380
Inversion Detection	350	LO/RE	117, 125, 148
Inversion Prevention Detection	350	LO/RE (LOCAL/REMOTE) Key Function Selection	169
IP00/Open Type Enclosure	39	LO/RE LED	117
IP20/NEMA Type 1 Enclosure	39	LO/RE Light	115
IP20/NEMA Type 1 Kit	438	LO/RE Selection Key	115
IP20/NEMA Type 1 Kit Selection	67	Load Current	552
J		Load Inertia	321, 553
Jog Frequency Reference	208	Load Inertia Ratio	204, 299, 544
Jump Frequency	211, 341	LOCAL	125
Jump Frequency Width	211	LOCAL/REMOTE Key Function Selection	554
K		LOCAL/REMOTE Run Selection	169
KEB Acceleration Time	292, 542	Loopback Test	623
KEB Deceleration Time	292, 542	Loss of Reference Function	300
KEB Detection Time	292	Low Voltage Directive	648
KEB Function Related Adjustments	291	Low Voltage Wiring for Control Circuit Terminals	671
		LSo	353
		LSo Fault	353
		LT-1	370

Index

LT-2	370	Minimum KEB Time	292
LT-3	370	Minimum Output Frequency	226
LT-4	370	Minimum Output Frequency Voltage	227
M		Minimum Output Voltage	336
M1	99	Minimum Wait Time for Sending Messages	620
M2	99	Minor Alarms	343
M3	99	Minor Fault	380
M4	99	Minor Fault and Alarm Displays	344
M5	99	Minor Faults	343
M6	99	Minor Faults and Alarms	342, 343
MA	99	Model, Voltage Class, Capacity Mismatch	385
Magnetic Flux Compensation Value	172	Model Number and Nameplate Check	35
Main Circuit Connection Diagram	75, 97	Modes	120
Main Circuit Terminal	50	Momentary Overcurrent Protection	473
Main Circuit Terminal and Motor Wiring	96	Momentary Power Loss Minimum Baseblock Time	291, 542
Main Circuit Terminal Block Configuration	79	Momentary Power Loss Operation Selection	175, 542
Main Circuit Terminal Functions	87	Momentary Power Loss Ride-Thru	286, 473
Main Circuit Terminal Wiring	50	Momentary Power Loss Ride-Thru Time	291, 542
Main Circuit Wiring	87	Momentary Power Loss Voltage Recovery Ramp Time	292, 542
Main Power Circuit Voltage Adjustment Gain	544	Monitor Output	99
Maintenance	265, 404	Monitor Parameters	274, 562
Maintenance Alarms	404	Most Recent Fault	566
Maintenance Monitors	331	Motor 1/Motor 2 Selection	141
Maintenance Monitor Settings	328	Motor 1 Parameters	227
Master Speed Reference Lower Limit	211	Motor 2 ASR Gain Switching Frequency	204
Maximum Applicable Motor Capacity	463, 464, 465, 466, 467, 468, 469, 470, 471	Motor 2 ASR Integral Limit	204
Maximum Output Frequency	226, 463, 464, 465, 466, 467, 468, 469, 470, 471	Motor 2 ASR Integral Time	204
Maximum Output Voltage	463, 464, 465, 466, 467, 468, 469, 470, 471	Motor 2 ASR Limit	204
Maximum Voltage	226	Motor 2 ASR Primary Delay Time Constant	204
MB	99	Motor 2 ASR Proportional Gain	204
MC	99	Motor 2 Base Frequency	230
Mechanical Weakening Detection	265	Motor 2 Base Voltage	230
Mechanical Weakening Detection 1	359, 371	Motor 2 Control Mode Selection	230
Mechanical Weakening Detection 2	363	Motor 2 Inertia	205
Mechanical Weakening Detection Operation	304, 546	Motor 2 Iron Loss	232
Mechanical Weakening Detection Speed Level	304, 547	Motor 2 Leakage Inductance	232
Mechanical Weakening Detection Start Time	305, 547	Motor 2 Line-to-Line Resistance	232
Mechanical Weakening Detection Time	305, 547	Motor 2 Load Inertia Ratio	205
MECHATROLINK-II Parameters	242	Motor 2 Max Output Frequency	230
MEMOBUS/Modbus Comm. Test Mode Complete	372	Motor 2 Max Voltage	230
MEMOBUS/Modbus Communication Error	347, 367	Motor 2 Mechanical Loss	232
MEMOBUS/Modbus Communications Reference	568	Motor 2 Mid Output Frequency	230
MEMOBUS/Modbus Communication Test Mode Error	373	Motor 2 Mid Output Frequency 2	230
MEMOBUS/Modbus Data Table	625	Motor 2 Mid Output Frequency Voltage	230
MEMOBUS/Modbus Error Code	563	Motor 2 Mid Output Frequency Voltage 2	230
MEMOBUS/Modbus Error Codes	642	Motor 2 Minimum Output Frequency	230
MEMOBUS/Modbus Setup Parameters	616	Motor 2 Minimum Output Frequency Voltage	230
MEMOBUS/Modbus Specifications	613	Motor 2 Motor Iron-Core Saturation Coefficient 1	232
MEMOBUS/Modbus Switch Settings	107	Motor 2 Motor Iron-Core Saturation Coefficient 2	232
MEMOBUS/Modbus Termination	50	Motor 2 Motor Poles	232
Menu Structure for Digital Operator	119	Motor 2 Parameters	231
Message Format	621	Motor 2 Rated Current	231
Middle Output Frequency	226	Motor 2 Rated No-Load Current	231
Middle Output Frequency 2	227	Motor 2 Rated Power	233
Middle Output Frequency Voltage	226	Motor 2 Rated Slip	231
Middle Output Frequency Voltage 2	227	Motor 2 Slip Compensation Gain	197
Mid Output Voltage A	336	Motor 2 Slip Compensation Limit	198
		Motor 2 Slip Compensation Primary Delay Time	197
		Motor 2 Slip Compensation Selection during Regeneration	198
		Motor 2 Torque Compensation Gain	199

Motor Acceleration Time	317	Motor Speed	562
Motor Acceleration Time for Inertia Calculations	298, 544	Motor Speed at Previous Fault	564
Motor Base Frequency	141, 142, 558	Motor Speed Error 2	382
Motor Base Speed	143, 558	Motor Speed Fault	381
Motor Code Selection	233, 594	Motor Stalls During Acceleration or With Large Loads	391
Motor Data Error	380	Motor Stator Resistance	234
Motor d-Axis Current at Previous Fault	565	Motor Switch during Run	373
Motor d-Axis Inductance	234	Motor Temperature (NTC)	568
Motor Direction at Power Up when Using Operator	327, 555	Motor Temperature Input Filter Time	283, 541
Motor Direction Error	381	Motor Wiring	96
Motor Does Not Rotate	389	Mounting Hole	43, 45, 46, 47, 48, 49
Motor Excitation Current (Id)	569	Mounting hole	42, 44
Motor Feedback Resolver Interface	437	MP	99
Motor Hunting and Oscillation Control Parameters	341	Multi-Function Analog Inputs	217
Motor Induction Voltage Constant 1	234	Multi-Function Analog Input Selection Error	377
Motor Induction Voltage Constant 2	235	Multi-Function Analog Input Terminal Settings	268
Motor Inertia	147, 204	Multi-Function Analog Outputs	200
Motor Iron-Core Saturation Coefficient	379	Multi-Function Analog Output Terminal AM Bias	274
Motor Iron-Core Saturation Coefficient 1	228	Multi-Function Analog Output Terminal AM Gain	274
Motor Iron-Core Saturation Coefficient 2	228	Multi-Function Analog Output Terminal AM Monitor Selection	274
Motor Iron Loss	143, 559	Multi-Function Analog Output Terminal AM Signal Level Selection	275
Motor Iron Loss for Torque Compensation	229	Multi-Function Analog Output Terminal FM Bias	274
Motor is Too Hot	390	Multi-Function Analog Output Terminal FM Gain	274
Motor Leakage Inductance	228	Multi-Function Analog Output Terminal FM Monitor Selection	274
Motor Line-to-Line Resistance	228	Multi-Function Analog Output Terminal FM Signal Level Selection	275
Motor Mechanical Loss	229	Multi-Function Digital Inputs	98, 125
Motor No-Load Current	143, 228	Multi-Function Digital Input Terminal Settings	247
Motor Overheat	371	Multi-Function Digital Output	99
Motor Overheat (NTC Input)	358, 371	Multi-Function Digital Outputs	258
Motor Overheat Alarm (PTC Input)	357	Multi-Function Digital Output Terminal Settings	258
Motor Overheat Alarm Operation Selection	283, 541	Multi-Function Input Selection Error	375
Motor Overheat Fault (PTC Input)	357	Multiple Drive Installation	55
Motor Overheat Fault Operation Selection	283, 541	Multiple Drive Wiring	97
Motor Overload	358	Multi-Step Speed Selection	163
Motor Overload Estimate (oL1)	567	L1-01	672
Motor Overload Protection Selection	265, 541, 672	N	
Motor Overload Protection Time	281, 541, 672	n1-02	336
Motor Parameters	223	n2-01	337
Motor Performance Fine-Tuning	336	n2-02	337
Motor PG Feedback Line Driver Interface	437	n2-03	337
Motor PG Feedback Open Collector Interface	437	Nameplate	35
Motor Poles	141	ND	205
Motor Produces Insufficient Torque	394	ndAT	385
Motor Protection	279	NetRef/ComRef Function Selection	243
Motor Protection Using a Positive Temperature Coefficient Thermistor	273	Network Termination	614
Motor PTC Characteristics	283	Noise From the Drive or Motor Cables When the Drive is Powered On	393
Motor Pull Out or Step Out Detection	363	No-Load Current Alarm	380
Motor q-Axis Current at Previous Fault	565	No-Load Current Error	380
Motor q-Axis Inductance	234	No-Load Operation	148
Motor Rated Current	141, 142, 227, 234, 558, 671	No-Load Operation Test Run	148
Motor Rated Power	142, 229, 234, 558	Normal Duty	205
Motor Rated Slip	143, 227	Normal Duty Ratings	205
Motor Rated Voltage	141, 142, 558	Notes on Inertia Tuning and ASR Gain Auto-Tuning	139
Motor Rotates After the Drive Output is Shut Off	394	Notes on Rotational Auto-Tuning	138
Motor Rotates Faster Than the Frequency Reference	392	Notes on Stationary Auto-Tuning	139
Motor Rotates in One Direction Only	390	nSE	354
Motor Secondary Current (Iq)	569		
Motor Selection	252		
Motor Selection 1/2	558		

Number of Auto Restart Attempts	301, 545	oPE15	378
Number of Motor Poles	142, 228, 234, 558	oPE16	378
Number of PM Motor Poles	145	oPE18	378
Number of Run Commands	566	oPE Fault Parameter	563
Number of Run Commands Counter Initialization	329	Open Loop Vector Control	32, 338, 392, 394
Number of Speed Search Restarts	178	Open Loop Vector Control for IPM Motors	32
O		Open Loop Vector Control for PM Motors	32
o2-01	389	Open Loop Vector Control Mode Tuning	337
o2-03	151	Open Loop Vector Control Mode Tuning Parameters ...	337, 338, 339, 340
o2-04	336	Operating with the Load Connected	150
oC	354	Operation Errors	342, 345
oFA00	355	Operation Selection at Deviation (dEv)	237
oFA01	355	Operation Selection at Overspeed (oS)	236
oFA03 to oFA06	355	Operation Selection at PG Open Circuit (PGo)	236
oFA10	355	Operation Selection when Digital Operator is Disconnected	327, 555
oFA11	355	Operation Status Monitors	331
oFA12 to oFA17	355	Operation with Permanent Magnet Motors	3
oFA30 to oFA43	355	Operator Programming Errors	375
oFb00	355	Operator Related Settings	324
oFb01	355	oPr	360
oFb02	356	Optional 24 V DC power supply connector cover	42, 43, 44, 45, 46, 47
oFb03 to oFb11	356	Option card connection error (CN5-A)	355
oFb12 to oFb17	356	Option Card Connection Error at Option Port CN5-A	355
oFC00	356	Option Card Connection Error at Option Port CN5-C	356
oFC01	356	Option card connector (CN5-A)	50
oFC02	356	Option card connector (CN5-B)	50
oFC03 to oFC11	356	Option card connector (CN5-C)	50
oFC12 to oFC17	356	Option card error occurred at option port CN5-A	355
oFC50 to oFC55	357	Option card error occurred at option port CN5-B	356
Offset Frequency	222, 570	Option card error occurred at option port CN5-C	356, 357
oH	357, 370	Option Card External Fault	351, 368
oH1	357	Option Card Fault at Option Port CN5-A	355
oH2	370	Option Card Fault at Option Port CN5-B	355, 356
oH3	357, 371	Option Card Fault at Option Port CN5-C	356
oH4	357	Option Communication Error	347, 366
oH5	358, 371	Option Frequency Reference	567
oH Alarm Location Monitor	568	Option Installation	440
oL1	358	Option Settings	236
oL2	358, 394	oS	360, 372
oL2 Characteristics Selection at Low Speeds	309, 548	Oscillation or Hunting	393
oL3	359, 371	Output Current	562
oL4	359, 371	Output Current 1 During Speed Search	176
oL5	359, 371	Output Current at Previous Fault	564
oL7	359	Output Current Imbalance	353
Online Tuning Gain	319	Output Frequency	562
Online Tuning Selection	319	Output Frequency after Soft Start	563
oPE	375	Output Frequency at Previous Fault	564
oPE01	375	Output Frequency is not as High as Frequency Reference	394
oPE02	375	Output Frequency Reduction During Overheat Alarm	307
oPE03	375	Output Frequency Resolution	472
oPE04	376	Output Ground Fault Detection Selection	308, 548
oPE05	376	Output of speed control (ASR) (for Simple V/f PG)	569
oPE06	376	Output Phase Loss	353
oPE07	377	Output Phase Loss Protection	548
oPE08	377	Output Phase Loss Protection Selection	308
oPE09	377	Output Power	562
oPE10	378	Output Power at Previous Fault	564
oPE11	378	Output Terminal Status	563
oPE13	378	Output Terminal Status at Previous Fault	565

Output Voltage at Previous Fault.....	564	PG 2 Gear Teeth 1.....	238
Output Voltage Detection Fault.....	365, 374	PG 2 Gear Teeth 2.....	238
Output Voltage Limit.....	322	PG 2 Pulses Per Revolution.....	236
Output Voltage Limit Operation Selection.....	197	PG 2 Rotation Selection.....	237
Output Voltage Reference.....	562	PG 2 Signal Selection.....	238
Output Voltage Reference (Vd).....	569	PG-B3.....	437
Output Voltage Reference (Vq).....	569	PG-B3 Settings.....	236
ov.....	360, 372	PG Disconnect (for any control modes using a PG option card).....	361
Overcurrent.....	354	PG Disconnect (for Control Mode with PG).....	372
Overcurrent Detection Gain.....	309, 548	PG Hardware Fault (detected when using a PG-X3 option card) ...	361, 372
Overexcitation Deceleration.....	296	PG Number of Pulses Per Revolution.....	143
Overexcitation Deceleration Gain.....	316, 551	PG Number of Pulses Per Revolution for PM Motor Tuning.....	146
Overexcitation Operation Selection.....	316, 551	PGo.....	361, 372
Overheat 1 (Heatsink Overheat).....	357	PGoH.....	361, 372
Overheat Alarm Level.....	265, 547	PG Open-Circuit Detection Time.....	236
Overheat Pre-Alarm Operation Selection.....	267, 547	PG Option Card Disconnection Detection 1.....	238
Overload Protection.....	473	PG Option Card Disconnection Detection 2.....	238
Overload Tolerance.....	463, 464, 465, 466, 467, 468, 469, 470, 471	PG Option Card Port for Motor 2 Selection.....	239
Overspeed.....	360, 372	PG-RT3.....	437
Overspeed Detection Delay Time.....	236	PG Speed Control Card Settings.....	236
Overspeed Detection Level.....	236	PG-X3.....	437
Overtorque 1.....	371	PG-X3 Settings.....	236
Overtorque 2.....	371	Phase Order Selection.....	169
Overtorque Detection 1.....	359	PID Accel/Decel Time.....	186
Overtorque Detection 2.....	359	PID Block Diagram.....	181
Overtorque Detection Operation.....	302	PID Control.....	179
Overvoltage.....	360	PID Feedback.....	568
Overvoltage Protection.....	473	PID Feedback High Detection Level.....	185
Overvoltage Suppression Function.....	297	PID Feedback High Detection Time.....	185
Overvoltage Suppression Function Selection.....	297	PID Feedback Input Methods.....	180
ov Suppression Function Selection.....	544	PID Feedback Loss.....	352, 369
P			
Parameter Access Level.....	151	PID Feedback Loss Detection Selection.....	184
Parameter Range Setting Error.....	375	PID Feedback Low Detection Level.....	184
Parameter Selection Error.....	377	PID Feedback Low Detection Time.....	185
Parameter Settings.....	121	PID Fine Tuning.....	188
Parameters for KEB Ride-Thru.....	290	PID Function Setting.....	182
Parameters that Change with the Motor Code Selection.....	594	PID Input (feedback).....	568
Parameters to Minimize Motor Hunting and Oscillation.....	341	PID Input Limit.....	187
PASS.....	372	PID Monitors.....	331
Password.....	151, 158	PID Offset Adjustment.....	183
Password Setting.....	158	PID Output.....	568
Password Settings.....	151	PID Output Fault.....	394
P Control.....	179	PID Output Gain Setting.....	183
Peak Hold Current.....	567	PID Output Level Selection.....	183
Peak Hold Output Frequency.....	567	PID Output Limit.....	182
Performance Life.....	403, 3	PID Output Lower Limit.....	186
Performance Life Monitors Maintenance Monitors.....	3	PID Output Reverse Selection.....	183
Periodic Inspection.....	401	PID Output Reverse Selection 2.....	187
Periodic Maintenance.....	265	PID Primary Delay Time Constant.....	183
Permanent Magnet Motor Control.....	3	PID Setpoint.....	569
PF.....	361	PID Setpoint Display Digits.....	187
PG 1 Division Rate for PG Pulse Monitor.....	237	PID Setpoint Input Methods.....	180
PG 1 Gear Teeth 1.....	238	PID Setpoint Scaling.....	186
PG 1 Gear Teeth 2.....	238	PID Setpoint Selection.....	186
PG 1 Pulses Per Revolution.....	236	PID Setpoint User Display.....	187
PG 1 Rotation Selection.....	237	PID Setpoint Value.....	186
PG 1 Signal Selection.....	238	PID Sleep.....	185
PG 2 Division Rate for PG Pulse Monitor.....	237	PID Sleep Delay Time.....	185
		PID Sleep Function Start Level.....	185

PM Inductance Error	382	Q	
PM Motor Auto-Tuning Mode Selection	143	q-axis ACR Output	569
PM Motor Base Frequency	145	R	
PM Motor Base Speed	145	R-	100
PM Motor Code	233	R/L1	87
PM Motor Code Selection	144	R+	100
PM Motor Control Tuning	319	R1-L11	87
PM Motor d-Axis Inductance	145	Radiated and Radio Frequency Noise	455
PM Motor Induced Voltage Constant	145	Ramp to stop	164
PM Motor Parameter Settings	136	Rated Current Depending on Carrier Frequency	206
PM Motor q-Axis Inductance	145	Rated Current Setting Alarm	379
PM Motor Rated Current	144	Rated Output Capacity	463, 464, 465, 466, 467, 468, 469, 470, 471
PM Motor Rated Power	144	Rated Output Current	463, 464, 465, 466, 467, 468, 469, 470, 471
PM Motor Rated Voltage	144	Rated Slip Error	381
PM Motor Settings	144	Rated Voltage, Rated Frequency ..	463, 464, 465, 466, 467, 468, 469, 470, 471
PM Motor Stator Resistance	145	rdEr	385
PM Motor Type	144	READ	327
PM Stationary Auto-Tuning	136	rEAd	385
PM Stationary Auto-Tuning for Stator Resistance	136	Reading Drive MEMOBUS/Modbus Register Contents	623
Polarity Judge Timeout	350	Reading Parameter Settings	385
Pole Attraction Current	319	Reattaching the Digital Operator	83
Power Detection Filter Time	191	Reattaching the Front Cover	85
Powering Up the Drive	131	Reattaching the Protective Cover	86
Power Ratings (Three-Phase 200 V Class)	463, 464, 465	Reattaching the Terminal Cover on an IP00/Open Type Enclosure Drive	82
Power Ratings (Three-Phase 400 V Class)	466, 467, 468	Reattaching the Terminal Cover on an IP20/NEMA Type 1 Enclosure Drive	81
Power Ratings (Three-Phase 600 V Class)	469, 470, 471	REMOTE	125
Power Unit Output Phase Loss 3	353	Removing the Cooling Fan	409
Predefined V/f Patterns	224	Removing the Digital Operator	83
Preface	18	Removing the Front Cover	83
Preparing the Ends of Shielded Cables	102	Removing the Protective Cover	86
Preset Reference Timing Diagram	210	Removing the Terminal Cover on an IP00/Open Type Enclosure Drive	82
Previous Fault	564	Removing the Terminal Cover on an IP20/NEMA Type 1 Enclosure Drive	81
PROFIBUS-DP Clear Mode Selection	244	Replacement Parts	403
PROFIBUS-DP Data Format Selection	244	Replacing the Drive	433
PROFIBUS-DP Node Address	244	Reset Communication Parameters	243
PROFIBUS-DP Parameters	242, 244	RESET Key	115
Programming Mode	120, 121	Resistance Tuning Error	379
Proportional Gain Setting (P)	182	Response Messages from Drive to Master	620
Protective Cover	55	Reverse Direction Output Example Time Chart	265
Protective Covers, Reattaching	82	Reverse Operation Selection	167
Protective Covers, Removing	81, 82	Reverse Prohibited Error	382
Protective cover to prevent miswiring	50	Reverse Regenerative Torque Limit	305, 547
PTC	273	Reverse Torque Limit	305, 547
Pull-In Current	320, 552	rF	361
Pull-In Current Compensation Time Constant	552	rH	362
Pull-In Current during Accel/Decel for PM	363	Rotational Auto-Tuning	135, 138
Pull-In Current Level for PM Motor Tuning	146	Rotational Auto-Tuning for V/f Control	135
Pulse Monitor Selection Error	378	RP	99
Pulse Output Connection Using External Voltage Supply	106	rr	362
Pulse Output Connection Using Internal Voltage Supply	105	RS-422 Interface	615
Pulse Train Input/Output	258	RS-485 Interface	614
Pulse Train Input Bias	277	RTS Control Selection	617
Pulse Train Input Filter Time	277	Rubber Bushing	42
Pulse Train Input Gain	277	rUn	373
Pulse Train Input Minimum Frequency	278		
Pulse Train Input Scaling	277		
Pulse Train Input Terminal RP Function Selection	276		
Pulse Train Monitor Scaling	278		
Pulse Train Monitor Selection	278		

Run Command/Frequency Reference Source Selection Error.....	376	Single Drive KEB Ride-Thru 1	287
Run Command at Power Up.....	170	Single Drive KEB Ride-Thru 2	287
Run Command Method Selection	618	Sink/source jumper S3	50
Run Command Selection	389	Sinking/Sourcing Mode Switch for Digital Inputs	50
Run Command Selection 1	163, 495	Slave Address	621
Run Command Selection 2	170	Slip Compensation.....	195
Run command selection while in Programming Mode	169	Slip Compensation Gain	195, 337
Run Command Source Selection	568	Slip Compensation Limit	196
RUN Key	115	Slip Compensation Primary Delay Time	196, 337
RUN LED.....	117	Slip Compensation Selection during Regeneration	196
RUN Light.....	115	SN.....	98
S		Soft Charge Bypass Relay Maintenance.....	566
S-.....	100	Soft Charge Bypass Relay Maintenance Time.....	370
S/L2.....	87	Soft CLA Selection.....	548
S+	100	Soft Starter Speed Reference at Previous Fault.....	565
S1	98	Software Current Limit Selection	309
S1-L21.....	87	Software No. (Flash)	564
S2	98	Software No. (PWM).....	564
S3	98	Software No. (ROM).....	564
S4	98	Software version	35
S5	98	Sound from Motor	394
S6	98	Space Between Drives (Side-by-Side Mounting)	55
S7	98	Speed/Torque Control Switchover Time	221
S8	98	Speed Agree 1 Time Chart	260
Safe Disable Circuit	675	Speed Agree 2 Time Chart	263
Safe Disable Function Wiring Example (SINK Mode).....	676	Speed Agreement Detection Level	300, 545
Safe Disable Input Function.....	675	Speed Agreement Detection Level (+/-).....	300, 545
Safe Disable Inputs	98	Speed Agreement Detection Selection.....	301
Safe Disable Monitor Output Function and Digital Operator Display	677	Speed Agreement Detection Width	300, 545
Safe Disable Signal Input.....	369	Speed Agreement Detection Width (+/-)	300, 545
Safety Hazard Definitions	20	Speed Control Accuracy	472
Safety Information.....	20	Speed Control Integral Time 1	372
Safety Input and EDM Terminal Status	677	Speed Control Loop Auto-Tuning.....	137
Safety Monitor Output	99	Speed Control Proportional Gain 1.....	372
Safety Standard	473	Speed Control Range.....	472
SC.....	98, 362	Speed Deviation (for Control Mode with PG).....	349
S-Curve Characteristics	195, 341	Speed Deviation (when using a PG option card)	367
SE.....	373	Speed Estimation Type Speed Search.....	174
Search Operation Voltage Limit.....	191	Speed Feedback Detection Control (AFR) Tuning.....	314
Self-diagnosing function of the serial communication interface circuits	643	Speed Feedback Detection Control (AFR) Gain	314, 550
SEr.....	362	Speed Feedback Detection Control (AFR) Time Constant 1	314, 550
Serial Communications Cable Connection Terminals (TB5).....	614	Speed Feedback Detection Control (AFR) Time Constant 2	314, 550
Serial Communication Terminals.....	100	Speed Feedback Detection Control Gain.....	320, 552
Serial Communication Transmission Error	366	Speed Feedback Detection Control Gain during ov Suppression	322
Serviceable Parts.....	432	Speed Limit.....	221
Setup Group	120	Speed Limitation.....	219
Setup Group Parameters	125	Speed Limit Bias.....	219, 221
Setup Mode.....	121	Speed Limit Selection.....	220
Shielded Twisted-Pair Cables.....	102	Speed Response	472
Short Circuit Brake Time at Start.....	172	Speed Search	165
Short Circuit Brake Time at Stop.....	172	Speed Search Deactivation Current	176
Short Circuit Braking Current.....	172	Speed Search Deceleration Time	176
Side-by-Side Installation.....	55	Speed Search Delay Time	176
Side-by-Side Mounting	486	Speed Search Detection Compensation Gain	177
Side-by-Side Setup	55	Speed Search Method Selection	178
Simple Motor Setup Using V/f Control.....	128	Speed Search Restart Current Level.....	177
Simplified Setup Using the Setup Group.....	121	Speed Search Restart Detection Time.....	178
		Speed Search Selection at Start	176
		Speed Search Wait Time.....	178
		Stall Prevention	293, 341

Stall Prevention Detection Time.....	299	Terminal Connections for Communication Self-Diagnostics.....	643
Stall Prevention Level during Acceleration.....	294, 543	Terminal Cover.....	42, 43, 44, 45, 46, 47, 48, 49, 81
Stall Prevention Level during Run.....	297, 544	Terminal Cover Screw.....	42
Stall Prevention Limit during Acceleration.....	294, 543	Terminal M1-M2 Function Selection.....	258
Stall Prevention Selection during Acceleration.....	293, 543	Terminal M1-M2 Output Selection.....	241
Stall Prevention Selection during Deceleration.....	295, 543	Terminal M3-M4 Output Selection.....	241
Stall Prevention Selection during Run.....	296, 543	Terminal P1-PC Output Selection.....	241
Standard Connection Diagram.....	72	Terminal P2-PC Output Selection.....	241
Starting Torque.....	472	Terminal P3-PC Output Selection.....	241
Start-Up Flowcharts.....	126	Terminal P4-PC Output Selection.....	241
Stationary Auto-Tuning.....	139	Terminal P5-PC Output Selection.....	241
Stationary Auto-Tuning 1.....	135	Terminal P6-PC Output Selection.....	241
Stationary Auto-Tuning 2.....	135	Terminal V1 Monitor Bias.....	240
Stationary Auto-Tuning for Line-to-Line Resistance.....	135	Terminal V1 Monitor Gain.....	240
Stator Resistance Error.....	382	Terminal V1 Monitor Selection.....	240
Status Display.....	131	Terminal V1 Signal Level.....	241
STo.....	363	Terminal V2 Monitor Bias.....	240
STOP button Input.....	380	Terminal V2 Monitor Gain.....	240
STOP Key.....	115	Terminal V2 Monitor Selection.....	240
STOP Key Function Selection.....	326, 554	Terminal V2 Signal Level.....	241
Stopping Method after Communication Error.....	616	Test Run.....	138, 139, 141, 148
Stopping Method Selection.....	164	Test Run Checklist.....	153
Storage Temperature.....	54	Test Run with Load Connected.....	150
Surrounding Area.....	54	Thermistor Disconnect.....	363, 373
SvE.....	363	THo.....	363, 373
Swing PWM.....	206, 462	Tightening Torque.....	89
Switching Between LOCAL and REMOTE.....	125	Timer Function Off-Delay Time.....	179
Switching Between Torque and Speed Control.....	219	Timer Function On-Delay Time.....	179
System KEB Ride-Thru 1.....	287	Too Many Speed Search Restarts.....	362
System KEB Ride-Thru 2.....	287	Top Protective Cover.....	42
T		Top protective Cover.....	44
T/L3.....	87	Torque Compensation.....	198
T1-03.....	141	Torque Compensation at Forward Start.....	199
T1-04.....	141	Torque Compensation at Reverse Start.....	199
T1-05.....	141	Torque Compensation Gain.....	198, 336
T1-06.....	141	Torque Compensation Primary Delay Time.....	199, 336
T1-07.....	141	Torque Compensation Primary Delay Time 2.....	199
T1-L31.....	87	Torque Compensation Primary Delay Time Constant 1.....	337
Target DC Bus Voltage for Overvoltage Suppression and Stall Prevention.....	297	Torque Compensation Primary Delay Time Constant 2.....	337
Task Complete.....	384	Torque Compensation Time Constant.....	199
Temperature Derating.....	309	Torque Control.....	217
Terminal A1 Bias Setting.....	269	Torque Control Block Diagram.....	217
Terminal A1 Function Selection.....	268	Torque Control Input Value Selection.....	217
Terminal A1 Gain Setting.....	269	Torque Control Reference Sources.....	217
Terminal A1 Signal Level Selection.....	268	Torque Control Selection.....	220
Terminal A2 Bias Setting.....	270	Torque Control Setting Error.....	378
Terminal A2 Function Selection.....	270	Torque Control Signal Polarity.....	218
Terminal A2 Gain Setting.....	270	Torque Detection.....	262
Terminal A2 Signal Level Selection.....	270	Torque Detection Level 1.....	304, 546
Terminal A3 Bias Setting.....	270	Torque Detection Level 2.....	304, 546
Terminal A3 Function Selection.....	270	Torque Detection Selection 1.....	303, 546
Terminal A3 Gain Setting.....	270	Torque Detection Selection 2.....	303, 546
Terminal A3 Signal Level Selection.....	269	Torque Detection Time 1.....	304, 546
Terminal Block Configuration.....	79	Torque Detection Time 2.....	304, 546
Terminal Board.....	42, 43, 44, 45, 46, 47, 48, 49, 50, 432	Torque Limit.....	273, 472
Terminal Board Connection Error.....	348	Torque Limit Control Method Selection during Accel/Decel.....	306, 547
Terminal Board Connector.....	50	Torque Limit Integral Time Constant.....	306, 547
Terminal Board Not Connected.....	349	Torque Limits.....	341
		Torque Reference.....	562
		Torque Reference / Torque Limit Selection from Comm. Option.....	242

Torque Reference at Previous Fault.....	565	Using the Pulse Train Output	105
Torque Reference Delay Time.....	220	Using the Safe Disable Function.....	675
Torque Saturation Error.....	382	Uv.....	373
Torque Specifications, Three Phase 200 V Class	89, 656	Uv1.....	364
Torque Specifications, Three Phase 400 V Class	91, 659	Uv2.....	364
Torque Specifications, Three Phase 600 V Class	94, 662	Uv3.....	364
Troubleshooting without Fault Display.....	3	Uv4.....	365
TrPC.....	373	V	
Tuning Errors.....	342	V/f Characteristics.....	472
Types of Alarms, Faults, and Errors	342	V/f Control.....	32
Types of Auto-Tuning for Induction Motors.....	135	V/f Control Mode Tuning	336
Types of Auto-Tuning for Permanent Magnet Motors	136	V/f Control Mode Tuning Parameters	336
U		V/f control using motor speed feedback	32
U/T1.....	87	V/f Control with Simple Speed Feedback.....	276
U1-01.....	389, 391	V/f Data Setting Error.....	378
U1-07.....	389	V/f Gain During Speed Search.....	176
U1-09.....	389	V/f Pattern Defaults	575
U2, U3 Initialization.....	329	V/f Pattern Display Unit.....	325
U2, U3 Initial Value Selection.....	555	V/f Pattern for Motor 1.....	223
U2-02.....	386	V/f Pattern for Motor 2.....	230
U2-03 through U2-17	386	V/f Pattern Selection	223, 391
U4-05.....	374	V/T2	87
UL3.....	363, 373	vAEr.....	385
UL4.....	363, 373	VERIFY.....	327
UL5.....	363	Verifying Parameter Changes.....	120
UL and CSA Standards	3	Verify Menu.....	120
UL Standards Compliance.....	89	vFyE.....	385
UnbC.....	364	voF.....	365, 374
Undertorque Detection 1.....	363, 373	voF Alarm Location Monitor	568
Undertorque Detection 2.....	363, 373	Voltage Class, Capacity Mismatch	385
Undertorque Detection Operation	303	Voltage drop calculation formula.....	89
Undervoltage	373	Voltage Error Compensation Time Constant	321
Undervoltage 3.....	364	vrFy.....	385
Undervoltage 3 (Soft-Charge Bypass Circuit Fault).....	364	W	
Undervoltage Detection Level (Uv1).....	292, 542	W/T3.....	87
Undervoltage Protection.....	473	Warranty Information	27
Unexpected Noise from Connected Machinery.....	393	Water Supply Pump Application	132
Unidirectional Speed Limit Bias.....	221	Watt Hour Output Example	268
Unit Code	326	Watt Hour Output Unit Selection.....	266
Unit Selection for MEMOBUS/Modbus Register 0025H.....	617	Watt Loss 200 V Class Three Phase Models.....	474
Unstable Motor Speed when Using PM	395	Watt Loss 400 V Class Three Phase Models.....	474
Up/Down 2 Function.....	212	Watt Loss Three-Phase 600 V Class Models.....	475
Up/Down 2 Operations.....	256	Wire Gauge, Three Phase 200 V Class	89, 656
Up/Down Command Operation.....	251	Wire Gauge, Three Phase 400 V Class	91, 659
Up/Down Frequency Reference Limit Selection.....	216	Wire Gauge, Three Phase 600 V Class	94, 662
Up Arrow Key.....	115	Wire Gauges.....	89
USB Copy Unit	152, 438	Wiring Checklist.....	110
USB port (type-B)	42, 43, 44, 45, 46, 47, 48, 49, 108	Wiring Diagram for 2-Wire Sequence	255
User Defaults.....	151	Wiring Distance.....	206
User Monitor Selection after Power Up	324, 554	Wiring the Control Circuit Terminal.....	81
User Parameter Automatic Selection.....	151, 161, 494	WRITE.....	327
User Parameter Default Value	326, 554	Writing Parameter Settings.....	384
User Parameters.....	151	Writing to Multiple Registers	624
User Parameters 1 to 32.....	151, 161, 494	Z	
User-Set Display Units Decimal Display.....	325	Zero Servo	192
User-Set Display Units Maximum Value.....	325	Zero Servo Completion Width.....	192
User Set Speed Agree 1 Time Chart	260	Zero Servo Fault	363
User Set Speed Agree 2 Example with a Positive L3-04 Value.....	263	Zero Servo Gain.....	192
Using Braking Units in Parallel.....	451		

Index

Zero-Speed Time Chart	259
Z Pulse Correction Error.....	383
Z Pulse Fault	349
Z Pulse Noise Fault Detection	350
Z Pulse Offset Tuning.....	136

This Page Intentionally Blank

Revision History

The revision dates and the numbers of the revised manuals appear on the bottom of the back cover.

Date of Publication	Revision Number	Section	Revised Content
May 2012	3	Front Cover	Revision: New format
		Chapter 8	Revision: Factory Recommended Branch Circuit Protection data
		Appendix A	Addition: Single-Phase Derating data
		Appendix D	Revision: Factory Recommended Branch Circuit Protection data
		All	Revision: Reviewed and corrected entire documentation. Upgraded drive software version to PRG: 1016 and PRG: 1017
		Back Cover	Revision: New format and address
November 2010	2	All	Addition: Larger drive capacities added along with corresponding data. Three-Phase 600V: 5A0125 to 5A0242 Revision: Reviewed and corrected documentation.
July 2010	1	All	Addition: Larger drive capacities added along with corresponding data. Three-Phase 400V: 4A0930 and 4A1200 Three-Phase 600V: 5A0041 to 5A0099 Revision: Reviewed and corrected documentation. Added software revision PRG: 1015
March 2010	-	-	First Edition. This manual supports drive software versions VSA90504□ and VSA901014.

YASKAWA AC Drive-A1000

High Performance Vector Control Drive

Technical Manual

YASKAWA AMERICA, INC.

2121 Norman Drive South, Waukegan, IL 60085, U.S.A.
Phone: (800) YASKAWA (927-5292) or 1-847-887-7000 Fax: 1-847-887-7310
<http://www.yaskawa.com>

DRIVE CENTER (INVERTER PLANT)

2-13-1, Nishimiyaichi, Yukuhashi, Fukuoka, 824-8511, Japan
Phone: 81-930-25-3844 Fax: 81-930-25-4369
<http://www.yaskawa.co.jp>

YASKAWA ELECTRIC CORPORATION

New Pier Takeshiba South Tower, 1-16-1, Kaigan, Minatoku, Tokyo, 105-6891, Japan
Phone: 81-3-5402-4502 Fax: 81-3-5402-4580
<http://www.yaskawa.co.jp>

YASKAWA ELÉTRICO DO BRASIL LTDA.

Avenda Fagundes Filho, 620 Bairro Saude, São Paulo, SP04304-000, Brasil
Phone: 55-11-3585-1100 Fax: 55-11-5581-8795
<http://www.yaskawa.com.br>

YASKAWA EUROPE GmbH

Hauptstrasse 185, 65760 Eschborn, Germany
Phone: 49-6196-569-300 Fax: 49-6196-569-398
<http://www.yaskawa.eu.com>

YASKAWA ELECTRIC UK LTD.

1 Hunt Hill Orchardton Woods, Cumbernauld, G68 9LF, United Kingdom
Phone: 44-1236-735000 Fax: 44-1236-458182
<http://www.yaskawa.co.uk>

YASKAWA ELECTRIC KOREA CORPORATION

9F, Kyobo Securities Bldg., 26-4, Yeouido-dong, Yeongdeungpo-gu, Seoul, 150-737, Korea
Phone: 82-2-784-7844 Fax: 82-2-784-8495
<http://www.yaskawa.co.kr>

YASKAWA ELECTRIC (SINGAPORE) PTE. LTD.

151 Lorong Chuan, #04-01, New Tech Park, 556741, Singapore
Phone: 65-6282-3003 Fax: 65-6289-3003
<http://www.yaskawa.com.sg>

YASKAWA ELECTRIC (SHANGHAI) CO., LTD.

12F, Carlton Bld., No.21 HuangHe Road, HuangPu District, Shanghai 200003, China
Phone: 86-21-5385-2200 Fax: 86-21-5385-3299
<http://www.yaskawa.com.cn>

YASKAWA ELECTRIC (SHANGHAI) CO., LTD. BEIJING OFFICE

Room 1011, Tower W3 Oriental Plaza, No. 1 East Chang An Ave.,
Dong Cheng District, Beijing, 100738, China
Phone: 86-10-8518-4086 Fax: 86-10-8518-4082

YASKAWA ELECTRIC TAIWAN CORPORATION

9F, 16, Nanking E. Rd., Sec. 3, Taipei, 104, Taiwan
Phone: 886-2-2502-5003 Fax: 886-2-2505-1280

YASKAWA ELECTRIC INDIA PRIVATE LIMITED

#17/A Electronics City, Hosur Road Bangalore 560 100 (Karnataka), India
Phone: 91-80-4244-1900 Fax: 91-80-4244-1901
<http://www.yaskawaindia.in>



YASKAWA ELECTRIC CORPORATION

In the event that the end user of this product is to be the military and said product is to be employed in any weapons systems or the manufacture thereof, the export will fall under the relevant regulations as stipulated in the Foreign Exchange and Foreign Trade Regulations. Therefore, be sure to follow all procedures and submit all relevant documentation according to any and all rules, regulations and laws that may apply.

Specifications are subject to change without notice for ongoing product modifications and improvements.

© 2010-2012 YASKAWA ELECTRIC CORPORATION. All rights reserved.

MANUAL NO. SIEP C710616 41D

Published in U.S.A May 2012 10-4

11-12-8_YAI